

Proximity Sensors

Section 18



Photoelectric Sensors

Section 19



IEC Limit Switches

Section 20



Encoders

Section 21



Current Sensors

Section 22



Pressure Sensors

Section 23



Temperature Sensors

Section 24



In this interactive PDF
you can:

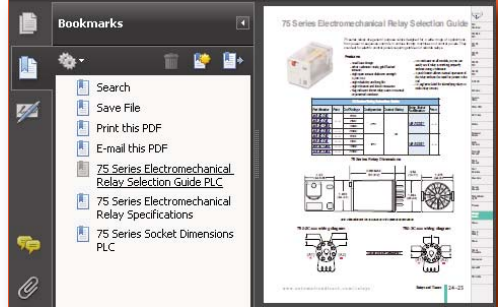

- Use bookmarks to navigate by product category
- Use bookmarks to save, search, print or e-mail the catalog section
- Click on part #s to link directly to our online store for current pricing, specs, stocking information and more



High-Quality, Rugged Encoders

Where can I use an encoder?

Encoders are used in all types of motion sensing applications, including machine tooling, semiconductor positioning and multi-axis positioning. All Koyo encoders feature a reinforced aluminum diecast casing and come equipped with a two-meter cable. Use these encoders with our PLC high-speed counter modules¹ for accurate position monitoring and control.

Why buy an encoder from us?

There are several distinct advantages to purchasing your encoder from AUTOMATIONDIRECT:

Availability

All common encoders are in stock and available to be shipped immediately. (We also offer non-stock encoders; see Price List or technical sheets for list of part numbers and lead times.)

Price

As with all of our product lines, our prices are often well below the list prices of traditional automation suppliers. Our direct business model allows us to operate more efficiently than other suppliers and pass the savings on to you.

Quality

All encoders carry a 1-year warranty, and all in-stock models have a 30-day money-back guarantee. If for any reason you are not satisfied with your purchase, send it back and we will refund your money.

What is a light-duty encoder?

A light-duty encoder is a cost-effective encoder for small applications. It offers the following features:

- Small body with 38 mm diameter and 30 mm depth
- Dustproof (IP40) rating
- 6 mm standard shaft or 8 mm hollow shaft
- Resolution available from 100 pulses/revolution to 2500 pulses/revolution
- Open collector or line driver outputs
- Up to 200 kHz response frequency

¹ Absolute encoders are not compatible with the high-speed counter modules.

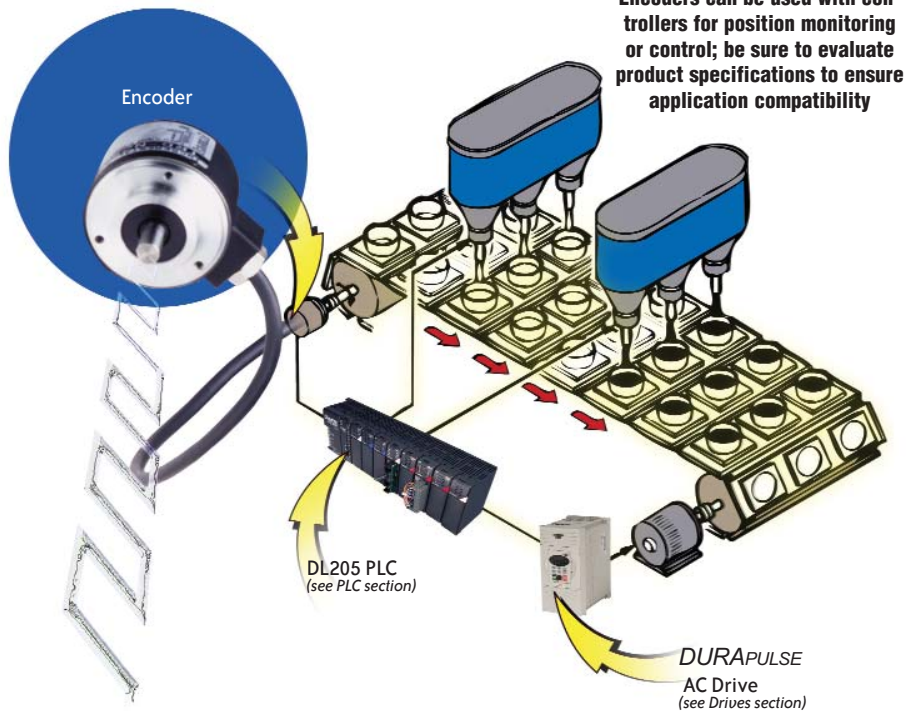

Encoders can be used with controllers for position monitoring or control; be sure to evaluate product specifications to ensure application compatibility

What is a medium-duty encoder?

A medium-duty encoder is the most popular encoder we offer. The product line offers the greatest flexibility of choice while maintaining very high quality, all for a very low price. Medium-duty encoders offer:

- Small body with 50 mm diameter and 35 mm depth
- Splash-proof (IP65) rating
- 8 mm standard shaft or 8 mm hollow shaft
- Incremental or absolute (gray code) operation
- Incremental resolution available from 30 pulses/revolution to 2500 pulses/revolution
- Absolute resolution available from 32 pulses/revolution to 1024 pulses/revolution
- Open collector, Totem-pole or line driver output versions
- Up to 100 kHz response frequency

What is a heavy-duty encoder?

A heavy-duty encoder is the most rugged encoder you can buy. Top-of-the-line bearings help maintain a service life of 12 billion revolutions. A heavy-duty encoder offers:

- Rugged body with 78 mm diameter and 60 mm depth
- Splash-proof (IP65) rating
- 10 mm standard shaft
- Incremental operation from 30 pulses/revolution to 5000 pulses/revolution
- Totem-pole output
- Up to 100 kHz response frequency

Great Selection at Great Prices



Encoder Selection Guide

Type	Incremental	Absolute	Standard Shaft	Hollow Shaft	Output*	Rating
Light-duty	X		X	X	OC, LD	IP40
Medium-duty	X	X (gray code)	X	X	P/P, LD, OC	IP65
Heavy-duty	X		X		P/P	IP65

* OC=open collector, P/P=push/pull, LD=line driver

Accessories

Couplings

Aluminum alloy and glass-fiber reinforced plastic couplings, including:
 6 mm to 6 mm
 8 mm to 8 mm
 10 mm to 10 mm



Aluminum alloy couplings, including:
 6 mm to 1/4"
 8 mm to 1/4", 3/8"
 10 mm to 1/4", 3/8"



Mounting brackets

Simplify your installation with a ready-to-use mounting device for medium and heavy-duty encoders



Encoder Selection Guide



Specification	TRD-S Series	TRD-SH Series	TRD-N Series
Description	Light duty incremental encoder with solid shaft	Light duty incremental encoder with hollow shaft	Medium duty incremental encoder with solid shaft
Size	Body: 38mm diameter and 30mm depth, Shaft: 6mm diameter	Body: 38mm diameter and 30mm depth, Shaft: 8mm diameter	Body: 50mm diameter and 35mm depth, Shaft: 8mm diameter
Output Configuration	NPN open collector or line driver	NPN open collector or line driver	Totem pole or line driver
Input Power	NPN open collector: 12-24VDC Line driver: 5VDC	NPN open collector: 12-24VDC Line driver: 5VDC	Totem pole: 5-30VDC Line driver: 5VDC
Resolutions Available	100 to 2500 pulses per revolution	100 to 2500 pulses per revolution	3 to 2500 pulses per revolution
Output Type	Cable (two meter, tinned)	Cable (two meter, tinned)	Cable (two meter, tinned)
Frequency Response	200kHz	200kHz	100kHz max.
Rating	IP40: dust proof	IP40: dust proof	IP40: dust proof; IP65: dust and splash proof
Accessories Available	Metric-to-metric and metric-to-S.A.E. couplings	Metric-to-metric and metric-to-S.A.E. couplings	Metric-to-metric and metric-to-S.A.E. couplings, mounting bracket
Page Reference	Page 20-5	Page 20-5	Page 20-8



Specification	TRD-NH Series	TRD-NA Series	TRD-GK Series	Couplings and Mounting Brackets
Description	Medium duty incremental encoder with hollow shaft	Medium duty absolute encoder with solid shaft	Heavy duty incremental encoder with solid shaft	Couplings for all standard shaft encoders and mounting brackets for medium and heavy duty encoders
Size	Body: 50mm diameter and 35mm depth, Shaft: 8mm diameter	Body: 50mm diameter and 35mm depth, Shaft: 8mm diameter	Body: 78mm diameter and 60mm depth, Shaft: 10mm diameter	-
Output Configuration	Totem pole or line driver	NPN open collector	Totem pole	-
Input Power	Totem pole: 5-30VDC Line driver: 5VDC	10-26VDC	10-30VDC	-
Resolutions Available	3 to 2500 pulses per revolution	32 to 1024 pulses per revolution	30 to 5000 pulses per revolution	-
Output Type	Cable (two meter, tinned)	Cable (two meter, tinned)	Cable (two meter, tinned)	-
Frequency Response	100kHz max.	20kHz	100kHz	-
Rating	IP40: dust proof; IP65: dust and splash proof	IP65: dust and splash proof	IP65: dust and splash proof	-
Accessories Available	Metric-to-metric and metric-to-S.A.E. couplings, mounting bracket	Metric-to-metric and metric-to-S.A.E. couplings, mounting bracket	Metric-to-metric and metric-to-S.A.E. couplings, mounting bracket	-
Page Reference	Page 20-8	Page 20-11	Page 20-14	Page 20-12, 20-13 and 20-15 (brackets) Page 20-16 (couplings)

Light Duty Incremental Encoders

Features

A light-duty encoder is a cost-effective encoder for small applications and has the following features:

- Small body with 38 mm diameter and 30 mm depth
- Dust proof (IP40 rating)
- 6 mm standard shaft or 8 mm hollow shaft
- Resolution available from 100 pulses per revolution to 2500 pulses per revolution
- Open collector or line driver output
- Up to 200 kHz response frequency
- Two-meter cable, tinned ends



Standard shaft (TRD-S) model



Hollow shaft (TRD-SH) model

Light Duty Standard Shaft Incremental Encoders (NPN Open Collector and Line Driver models)					
Part Number	Price	Pulses per Revolution	Input Voltage	Output	Body Diameter
TRD-S100-BD	<--->	100	12-24 VDC	NPN open collector	38mm
TRD-S200BD	<--->	200			
TRD-S250BD	<--->	250			
TRD-S300BD	<--->	300			
TRD-S360-BD	<--->	360			
TRD-S400BD	<--->	400			
TRD-S500-BD	<--->	500			
TRD-S600BD	<--->	600			
TRD-S800BD	<--->	800			
TRD-S1000-BD	<--->	1000			
TRD-S1024-BD	<--->	1024			
TRD-S1200BD	<--->	1200			
TRD-S2000BD	<--->	2000			
TRD-S2500-BD	<--->	2500			
TRD-S100-VD	<--->	100			
TRD-S200VD	<--->	200			
TRD-S250VD	<--->	250			
TRD-S300VD	<--->	300			
TRD-S360-VD	<--->	360			
TRD-S400VD	<--->	400			
TRD-S500-VD	<--->	500			
TRD-S600VD	<--->	600			
TRD-S800VD	<--->	800			
TRD-S1000-VD	<--->	1000			
TRD-S1024-VD	<--->	1024			
TRD-S1200VD	<--->	1200			
TRD-S2000VD	<--->	2000			
TRD-S2500-VD	<--->	2500			

Light Duty Hollow Shaft Incremental Encoders (NPN Open Collector and Line Driver models)					
Part Number	Price	Pulses per Revolution	Input Voltage	Output	Body Diameter
TRD-SH100-BD	<--->	100	12-24 VDC	NPN open collector	38mm
TRD-SH200BD	<--->	200			
TRD-SH250BD	<--->	250			
TRD-SH300BD	<--->	300			
TRD-SH360-BD	<--->	360			
TRD-SH400BD	<--->	400			
TRD-SH500-BD	<--->	500			
TRD-SH600BD	<--->	600			
TRD-SH800BD	<--->	800			
TRD-SH1000-BD	<--->	1000			
TRD-SH1024BD	<--->	1024			
TRD-SH1200BD	<--->	1200			
TRD-SH2000BD	<--->	2000			
TRD-SH2500-BD	<--->	2500			
TRD-SH100-VD	<--->	100			
TRD-SH200VD	<--->	200			
TRD-SH250VD	<--->	250			
TRD-SH300VD	<--->	300			
TRD-SH360-VD	<--->	360			
TRD-SH400VD	<--->	400			
TRD-SH500-VD	<--->	500			
TRD-SH600VD	<--->	600			
TRD-SH800VD	<--->	800			
TRD-SH1000-VD	<--->	1000			
TRD-SH1024VD	<--->	1024			
TRD-SH1200VD	<--->	1200			
TRD-SH2000VD	<--->	2000			
TRD-SH2500-VD	<--->	2500			

Company Info.

PLCs

Field I/O

Software

C-more & other HMI

AC Drives

AC Motors

Power Transmiss.

Steppers/ Servos

Motor Controls

Proximity Sensors

Photo Sensors

Limit Switches

Encoders

Current Sensors

Pressure Sensors

Temp. Sensors

Pushbuttons/ Lights

Process

Relays/ Timers

Comm.

Terminal Blocks & Wiring

Power

Circuit Protection

Enclosures

Tools

Pneumatics

Appendix

Part Index

Light Duty Incremental Encoders

Specifications

Electrical Specifications				
Model		TRD-Sxxxx-BD TRD-SHxxxxBD (open collector)	TRD-Sxxxx-VD TRD-SHxxxxVD (line driver)	
Power Supply	Operating Voltage	10.8 - 26.4VDC*	+4.75 - 5.25VDC*	
	Allowable Ripple	3% max.	-	
	Current Consumption	50 mA max.		
Signal Waveform		Two-phase + home position		
Max. Response Frequency		200kHz		
Duty Ratio		50 ± 25%		
Phase Difference Width		25 ± 12.5%		
Signal Width at Home Position		100 ± 50%		
Output	Rise/Fall Time		1µs max. (when cable length is 1m)	-
	Output Type		NPN open collector output, sinking	Line driver output (26C31 or equivalent)
	Output Logic		Negative logic (active low)	Negative logic (active high)
	Output Current	H	-	2.5 V min.
		L	0.4 V max.	0.5 V max.
	Output Voltage		0.4 V max.	0.5 V max.
	Influx Current		30mA max.	-
	Load Power Voltage		35 VDC max.	-
Short-Circuit Protection		Between output and power supply		
* To be supplied by Class II source				
Mechanical Specifications				
Starting Torque	Max. 0.001 Nm (.00074 ft./lbs)			
Max. Allowable Shaft Load	Radial: 20N (4.5 lbs) Axial: 10N (2.25 lbs)			
Max. Allowable Speed	6000 rpm (highest speed that can support the mechanical integrity of encoder)			
Wire Size	AWG26			
Weight	Approx. 150g (5.3 oz) with 2m cable			
Environmental Specifications				
Ambient Temperature	10 to 70°C; 14 to 158°F			
Storage Temperature	-25 to 85°C; -13 to 185°F			
Operating Humidity	35-85% RH			
Voltage Withstand	500VAC (50/60Hz) for one minute			
Insulation Resistance	50MΩ min.			
Vibration Resistance	Durable for one hour along three axes at 10 to 55 Hz with 0.75 amplitude			
Shock Resistance	11 ms with 490 m/s ² applied three times along three axes			
Protection	IP40: dust proof			

Accessories

Couplings

If you selected an encoder with a solid shaft, please select a coupling that fits your encoder. All couplings are in stock, ready to ship.

See page 20-16 for more information on couplings.

Mounting brackets are not available for light-duty encoders.

Light Duty Incremental Encoders

Dimensions

Standard shaft models

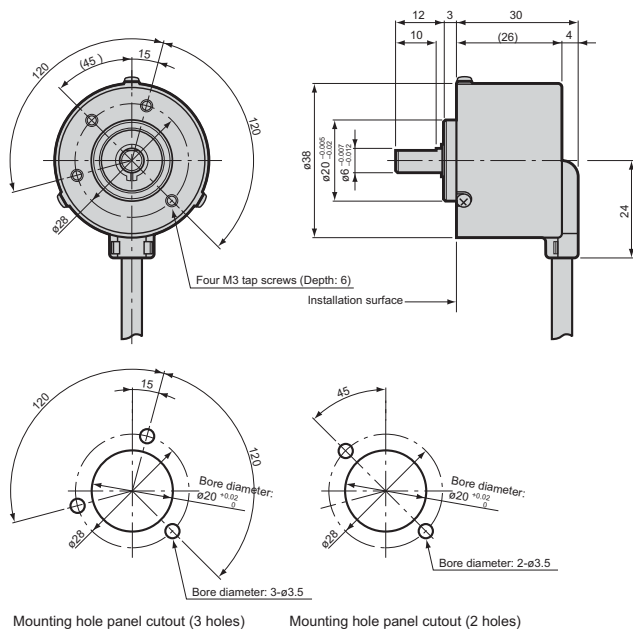

Hollow shaft models

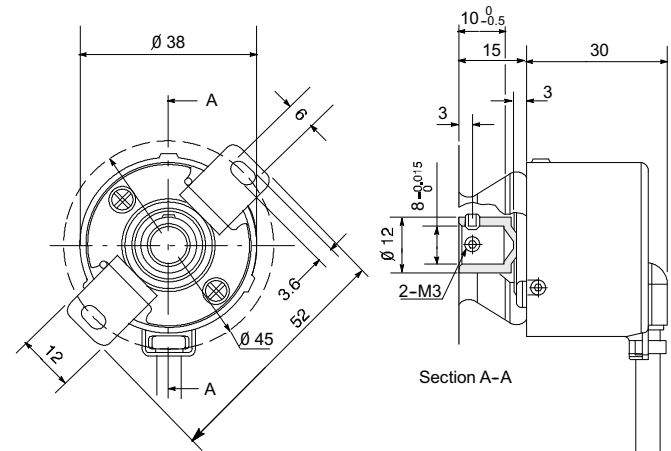

All dimensions in mm
1mm = 0.03937in

Wiring diagrams

Open collector connections

Cable shield is not connected to the encoder body; enclosure is grounded through the 0V wire

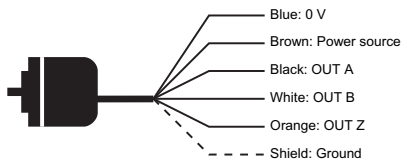

Line driver connections

Cable shield is not connected to the encoder body; enclosure is grounded through the 0V wire

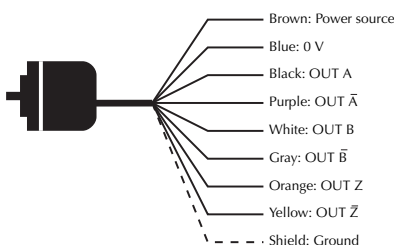

Channel timing charts

Open Collector Models

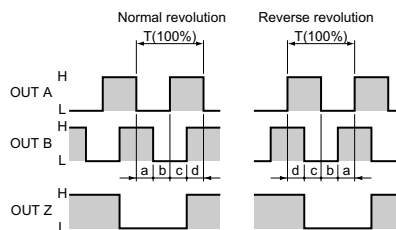

Line Driver Models

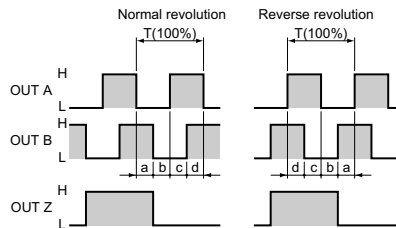

a, b, c, = 1/4T ± 1/8T
"Normal" means clockwise revolution viewed from the shaft.

How to read the timing charts

Open Collector Models

Out A and Out B are 90 degrees out of phase. Like any quadrature encoder, four unique logic states are created internally to the encoder. This is based on the rising edge to rising edge (one cycle) on channel A or B that indicates one set of bars on the internal encoder disk has passed by the optical sensor.

OUT Z is the absolute reference added to an incremental encoder and is also known as home position. It signifies a full rotation of the encoder disk.

Line Driver Models

Channel A (OUT A and A-not) and Channel B (OUT B and B-not) are also 90 degrees out of phase on line driver encoders. OUT Z is the same as on open collector models, and is the absolute reference (home position). It signifies one full rotation of the encoder.

Medium Duty Incremental Encoders

Features

The medium duty encoder offers the greatest flexibility of choice in a very high-quality encoder, all for a very low price.

Features:

- Small body with 50 mm diameter and 35 mm depth
- Splash proof (IP65 rating)
- 8 mm standard shaft or 8 mm hollow shaft
- Incremental resolution available from 3 pulses per revolution to 2500 pulses per revolution
- Line driver or Totem-pole output
- Up to 100 kHz response frequency



Standard shaft (TRD-N) model



Hollow shaft (TRD-NH) model



Incremental Medium Duty Standard Shaft Encoders (Totem-pole Output, TRD-Nxxx-RZVD)					
Part Number	Price	Pulses per Revolution	Input Volt-age	Output	Body Dia.
TRD-N3-RZVD	<--->	3	5-30 VDC	Totem-pole sink/source	50mm
TRD-N4-RZVD	<--->	4			
TRD-N5-RZVD	<--->	5			
TRD-N10-RZVD	<--->	10			
TRD-N30-RZVD	<--->	30			
TRD-N40-RZVD	<--->	40			
TRD-N50-RZVD	<--->	50			
TRD-N60-RZVD	<--->	60			
TRD-N100-RZVD	<--->	100			
TRD-N120-RZVD	<--->	120			
TRD-N200-RZVD	<--->	200			
TRD-N240-RZVD	<--->	240			
TRD-N250-RZVD	<--->	250			
TRD-N300-RZVD	<--->	300			
TRD-N360-RZVD	<--->	360			
TRD-N400-RZVD	<--->	400			
TRD-N480-RZVD	<--->	480			
TRD-N500-RZVD	<--->	500			
TRD-N600-RZVD	<--->	600			
TRD-N750-RZVD	<--->	750			
TRD-N1000-RZVD	<--->	1000			
TRD-N1024-RZVD	<--->	1024			
TRD-N1200-RZVD	<--->	1200			
TRD-N2000-RZVD	<--->	2000			
TRD-N2500-RZVD	<--->	2500			

Incremental Medium Duty Hollow Shaft Encoders (Totem-pole Output, TRD-NHxxx-RZVD)					
Part Number	Price	Pulses per Revolution	Input Volt-age	Output	Body Dia.
TRD-NH3-RZVD	<--->	3	5-30 VDC	Totem-pole sink/source	50mm
TRD-NH4-RZVD	<--->	4			
TRD-NH5-RZVD	<--->	5			
TRD-NH10-RZVD	<--->	10			
TRD-NH30-RZVD	<--->	30			
TRD-NH40-RZVD	<--->	40			
TRD-NH50-RZVD	<--->	50			
TRD-NH60-RZVD	<--->	60			
TRD-NH100-RZVD	<--->	100			
TRD-NH120-RZVD	<--->	120			
TRD-NH200-RZVD	<--->	200			
TRD-NH240-RZVD	<--->	240			
TRD-NH250-RZVD	<--->	250			
TRD-NH300-RZVD	<--->	300			
TRD-NH360-RZVD	<--->	360			
TRD-NH400-RZVD	<--->	400			
TRD-NH480-RZVD	<--->	480			
TRD-NH500-RZVD	<--->	500			
TRD-NH600-RZVD	<--->	600			
TRD-NH750-RZVD	<--->	750			
TRD-NH1000-RZVD	<--->	1000			
TRD-NH1200-RZVD	<--->	1200			
TRD-NH2000-RZVD	<--->	2000			
TRD-NH2500-RZVD	<--->	2500			

Medium Duty Incremental Encoders

Company Info.

PLCs

Field I/O

Software

C-more & other HMI

AC Drives

AC Motors

Power Transmiss.

Steppers/ Servos

Motor Controls

Proximity Sensors

Photo Sensors

Limit Switches

Encoders

Current Sensors

Pressure Sensors

Temp. Sensors

Pushbuttons/ Lights

Process

Relays/ Timers

Comm.

Terminal Blocks & Wiring

Power

Circuit Protection

Enclosures

Tools

Pneumatics

Appendix

Part Index

Incremental Medium Duty Standard Shaft Encoders (Line Driver Output, TRD-Nxxx-RZVWD)					
Part Number	Price	Pulses per Revolution	Input Voltage	Output	Body Dia.
TRD-N3-RZVWD	<-->	3	5VDC	Line driver (differential)	50mm
TRD-N4-RZVWD	<-->	4			
TRD-N5-RZVWD	<-->	5			
TRD-N10-RZVWD	<-->	10			
TRD-N30-RZVWD	<-->	30			
TRD-N40-RZVWD	<-->	40			
TRD-N50-RZVWD	<-->	50			
TRD-N60-RZVWD	<-->	60			
TRD-N100-RZVWD	<-->	100			
TRD-N120-RZVWD	<-->	120			
TRD-N200-RZVWD	<-->	200			
TRD-N240-RZVWD	<-->	240			
TRD-N250-RZVWD	<-->	250			
TRD-N300-RZVWD	<-->	300			
TRD-N360-RZVWD	<-->	360			
TRD-N400-RZVWD	<-->	400			
TRD-N480-RZVWD	<-->	480			
TRD-N500-RZVWD	<-->	500			
TRD-N600-RZVWD	<-->	600			
TRD-N750-RZVWD	<-->	750			
TRD-N1000-RZVWD	<-->	1000			
TRD-N1024-RZVWD	<-->	1024			
TRD-N1200-RZVWD	<-->	1200			
TRD-N2000-RZVWD	<-->	2000			
TRD-N2500-RZVWD	<-->	2500			

Incremental Medium Duty Hollow Shaft Encoders (Line Driver Output, TRDH-Nxxx-RZVWD)					
Part Number	Price	Pulses per Revolution	Input Voltage	Output	Body Dia.
TRD-NH3-RZVWD	<-->	3	5VDC	Line driver (differential)	50mm
TRD-NH4-RZVWD	<-->	4			
TRD-NH5-RZVWD	<-->	5			
TRD-NH10-RZVWD	<-->	10			
TRD-NH30-RZVWD	<-->	30			
TRD-NH40-RZVWD	<-->	40			
TRD-NH50-RZVWD	<-->	50			
TRD-NH60-RZVWD	<-->	60			
TRD-NH100-RZVWD	<-->	100			
TRD-NH120-RZVWD	<-->	120			
TRD-NH200-RZVWD	<-->	200			
TRD-NH240-RZVWD	<-->	240			
TRD-NH250-RZVWD	<-->	250			
TRD-NH300-RZVWD	<-->	300			
TRD-NH360-RZVWD	<-->	360			
TRD-NH400-RZVWD	<-->	400			
TRD-NH480-RZVWD	<-->	480			
TRD-NH500-RZVWD	<-->	500			
TRD-NH600-RZVWD	<-->	600			
TRD-NH750-RZVWD	<-->	750			
TRD-NH1000-RZVWD	<-->	1000			
TRD-NH1024-RZVWD	<-->	1024			
TRD-NH1200-RZVWD	<-->	1200			
TRD-NH2000-RZVWD	<-->	2000			
TRD-NH2500-RZVWD	<-->	2500			

Wiring diagrams

Totem-pole connections

Cable shield is not connected to the encoder body; enclosure is grounded through the 0V wire

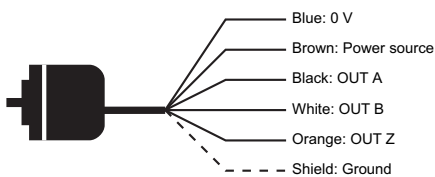

Line driver connections

Cable shield is not connected to the encoder body; enclosure is grounded through the 0V wire

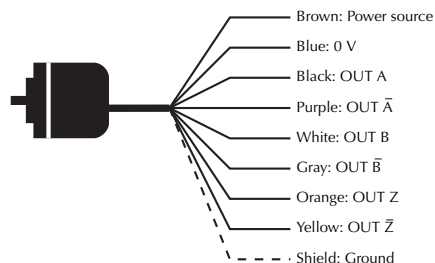

Medium Duty Incremental Encoders

Electrical Specifications				
Model		TRD-N/NHxxxx-RZWD (Totem-pole)	TRD-N/NHxxxx-RZVWD (Line Driver)	
Power Supply	Operating Voltage	4.75 - 30VDC*	+4.75 - 5.25VDC*	
	Allowable Ripple	3% rms max.	-	
	Current Consumption	60 mA max.		
Signal Waveform		Two-phase + home position		
Max. Response Frequency		100kHz max.		
Duty Ratio		50 ± 25% (square wave)		
Signal Width at Home Position		100 ± 50%		
Output	Rise/Fall Time	3µs max. (when cable length is 1m)	-	
	Output Type	Totem-pole	Line driver output (26C31 or equivalent)	
	Output Logic	Negative logic (active low)	Negative logic (active high)	
	Output Current	"H"	10mA max.	-
		"L"	30mA max.	-
	Output Voltage	"H"	[(Load power volt) - 2.5V]	-
"L"		0.4V max.	-	
Load Power Voltage		35 VDC max.		

* To be supplied by Class II source

Mechanical Specifications	
Starting Torque	Max. 0.03 Nm (.0022 ft lbs)
Max. Allowable Shaft Load	Radial: 50N (11.24 lbs) Axial: 30N (6.74 lbs)
Max. Allowable Speed	5000 rpm (dust and splash proofed: continuous: 3,000 rpm, instantaneous: 5,000 rpm) (highest speed that can support the mechanical integrity of encoder)
Wire Size	AWG24
Weight	Approx. 250g (8.82 oz) with 2m cable
Environmental Specifications	
Ambient Temperature	10 to 70°C; 14 to 158°F
Storage Temperature	-25 to 85°C; -13 to 185°F
Operating Humidity	35-85% RH
Voltage Withstand	500VAC (50/60Hz) for one minute
Insulation Resistance	50MΩ min. (excluding shield between power supply, signal cable and case)
Vibration Resistance	Durable for one hour along three axes at 10 to 55 Hz with 0.75 mm amplitude (excluding shield between power supply, signal cable and case)
Shock Resistance	11 ms with 490 m/s ² applied three times along three axes
Protection	IP50: dust proof; IP65: dust and splash proof

Channel timing chart

Output Signal Timing Chart - Totem Pole Models

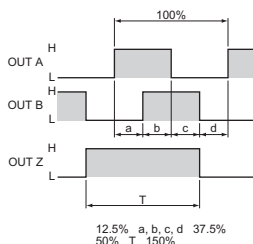

The above waveforms apply to normal (clockwise) revolution viewed from the shaft. OUT Z phase is reversed on the RZL and RZWL models.

Accessories

Couplings

If you selected an encoder with a solid shaft, please select a coupling that fits your encoder. All couplings are in stock, ready to ship.

See page 20-16 for more information.

Mounting bracket

JT-035D metal mounting bracket can be used for all TRD-N/NH/NA encoders.



How to read the timing charts

Open Collector Models

Out A and Out B are 90 degrees out of phase. Like any quadrature encoder, four unique logic states are created internal to the encoder. This is based on the rising edge to rising edge (one cycle) on channel A or B that indicates that one set of bars on the internal encoder disk has passed by the optical sensor.

OUT Z is the absolute reference added to an incremental encoder and is also known as home position. It signifies a full rotation of the encoder disk.

Line Driver Models

Channel A (OUT A and A-not) and Channel B (OUT B and B-not) are also 90 degrees out of phase on line driver encoders. OUT Z is the same as on open collector models, and is the absolute reference (home position). It signifies one full rotation of the encoder.

Medium Duty Absolute Encoders

Features

Why use an absolute encoder? When power is cycled using an incremental encoder, any positioning information is lost until **home** position is triggered. An absolute encoder uses gray code to describe each position, so position data is not lost when power is cycled. Features include:

- Small body with 50 mm diameter and 35 mm depth
- Splash proof (IP65 rating)
- 8 mm standard shaft
- Absolute resolution available from 32 pulses per revolution to 1024 pulses per revolution
- Open collector output
- Up to 100 kHz response frequency



Standard shaft (TRD-NA) model

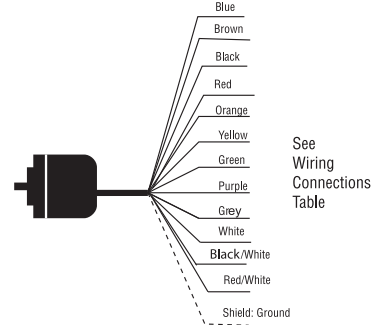

Absolute Medium Duty Standard Shaft Encoders					
Part Number	Price	Resolution	Input Voltage	Output	Body Dia.
TRD-NA32NWD	<--->	5 bit gray code, 32 pulses per revolution	10-26 VDC	NPN open collector	50mm
TRD-NA64NWD	<--->	6 bit gray code, 64 pulses per revolution			
TRD-NA128NWD	<--->	7 bit gray code, 128 pulses per revolution			
TRD-NA180NWD	<--->	8 bit gray code, 180 pulses per revolution			
TRD-NA256NWD	<--->	8 bit gray code, 256 pulses per revolution			
TRD-NA360NWD	<--->	9 bit gray code, 360 pulses per revolution			
TRD-NA512NWD	<--->	9 bit gray code, 512 pulses per revolution			
TRD-NA720NWD	<--->	10 bit gray code, 720 pulses per revolution			
TRD-NA1024NWD	<--->	10 bit gray code, 1024 pulses per revolution			

Wiring Connections							
Wire color	Connector Pin No.	1024/720 Resolution	512/360 Resolution	256/180 Resolution	128 Resolution	64 Resolution	32 Resolution
Blue	1	0V	0V	0V	0V	0V	0V
Brown	2	12/24V	12/24V	12/24V	12/24V	12/24V	12/24V
Black	3	bit 1 (2 ⁰)	No connection	No connection	No connection	No connection	No connection
Red	4	bit 2 (2 ¹)	bit 1 (2 ⁰)	No connection	No connection	No connection	No connection
Orange	5	bit 3 (2 ²)	bit 2 (2 ¹)	bit 1 (2 ⁰)	No connection	No connection	No connection
Yellow	6	bit 4 (2 ³)	bit 3 (2 ²)	bit 2 (2 ¹)	bit 1 (2 ⁰)	No connection	No connection
Green	7	bit 5 (2 ⁴)	bit 4 (2 ³)	bit 3 (2 ²)	bit 2 (2 ¹)	bit 1 (2 ⁰)	No connection
Purple	8	bit 6 (2 ⁵)	bit 5 (2 ⁴)	bit 4 (2 ³)	bit 3 (2 ²)	bit 2 (2 ¹)	bit 1 (2 ⁰)
Gray	9	bit 7 (2 ⁶)	bit 6 (2 ⁵)	bit 5 (2 ⁴)	bit 4 (2 ³)	bit 3 (2 ²)	bit 2 (2 ¹)
White	10	bit 8 (2 ⁷)	bit 7 (2 ⁶)	bit 6 (2 ⁵)	bit 5 (2 ⁴)	bit 4 (2 ³)	bit 3 (2 ²)
Black/white	11	bit 9 (2 ⁸)	bit 8 (2 ⁷)	bit 7 (2 ⁶)	bit 6 (2 ⁵)	bit 5 (2 ⁴)	bit 4 (2 ³)
Red/white	12	bit 10 (2 ⁹) (MSB)	bit 9 (2 ⁸) (MSB)	bit 8 (2 ⁷) (MSB)	bit 7 (2 ⁶) (MSB)	bit 6 (2 ⁵) (MSB)	bit 5 (2 ⁴) (MSB)
-	13	Not connected	Not connected	Not connected	Not connected	Not connected	Not connected
Shield*	-	GND	GND	GND	GND	GND	GND

Note: Numbers in parentheses () are the bits corresponding to binary code.

* GND (shielded cable) is not connected to encoder body; the enclosure is grounded through the 0VDC line.

Note: Modules that support absolute encoder signals at high speed (220 Hz) are not currently offered.

Medium Duty Absolute Encoders

Electrical Specifications		
Model		TRD-NAxxx-NWD
Power Supply	Operating Voltage	10.8 - 26.4VDC*
	Allowable Ripple	3% rms max.
	Current Consumption	70 mA max.
Output Code		Gray binary (38 gray codes at 180 resolution, 76 at 360 resolution, and 152 at 720 resolution)
Max. Response Frequency		20kHz (Maximum revolution speed = (max. response frequency / resolution) x 60. The encoder does not respond to revolution faster than the maximum speed.)
Accuracy		$\frac{360}{\text{Resolution} \times 2}$ = degree of accuracy
Direction of Rotation		Normal (CW) or reversed (CCW) (When viewed from the shaft, CW is clockwise direction, and CCW is counterclockwise direction)
Rise/Fall Time		2µs max. (at 1kW load resistance and when cable length is 2m or less)
Output	Output Type	NPN open collector
	Output Logic	Negative logic (active low)
	Sinking Current	16mA
	Residual Voltage	0.4V max.
	Load Power Voltage	30VDC max.
* To be supplied by Class II source		
Mechanical Specifications		
Starting Torque	Max. 0.03 Nm (.0022 ft lbs) max. at 20°C (68°F)	
Max. Allowable Shaft Load	Radial: 50N (11.24 lbs) Axial: 30N (6.74 lbs)	
Max. Allowable Speed	Continuous: 3,000 rpm, instantaneous: 5,000 rpm; (highest speed that can support the mechanical integrity of encoder)	
Wire Size	AWG26	
Weight	Approx. 300g (10.58 oz) with 2m cable	
Environmental Specifications		
Ambient Temperature	10 to 60°C; 14 to 140°F	
Storage Temperature	-25 to 85°C; -13 to 185°F	
Operating Humidity	25-85% RH (with no condensation)	
Insulation Resistance	10MΩ min.	
Vibration Resistance	Durable for one hour along three axes at 10 to 55 Hz with 0.75 mm amplitude	
Shock Resistance	11 ms with 980 m/s ² applied three times along three axes	
Protection	IP65: dust and splash proof	

Accessories

Couplings

If you selected an encoder with a solid shaft, please select a coupling that fits your encoder. All couplings are in stock, ready to ship.

See page 20-16 for more information.

Mounting bracket

JT-035D metal mounting bracket can be used for all TRD-N/NH/NA encoders.

Medium Duty Absolute and Incremental

Dimensions

The following are the external dimensions of both incremental and absolute medium duty encoders and the optional mounting bracket.

Standard shaft incremental and absolute encoders (TRD-N, TRD-NA)

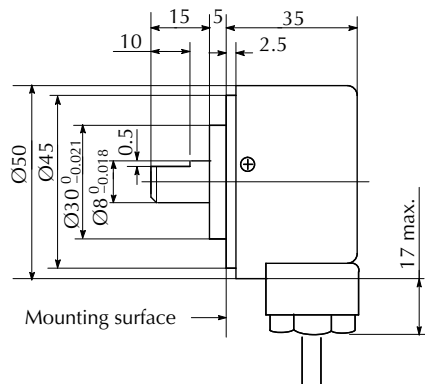
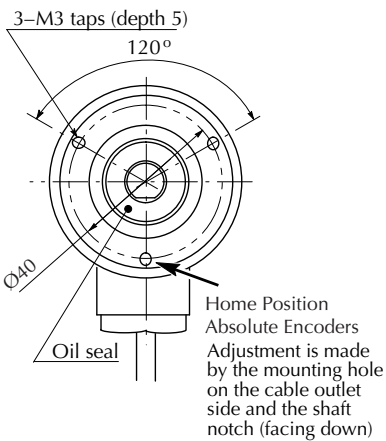

Hollow shaft incremental encoders only (TRD-NH)

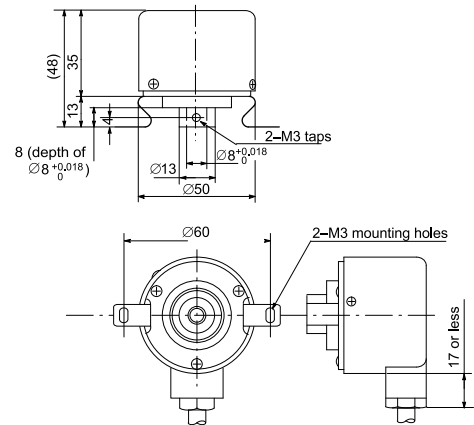

All dimensions in mm
1mm = 0.03937in

Optional mounting bracket for all medium duty encoders



JT-035D

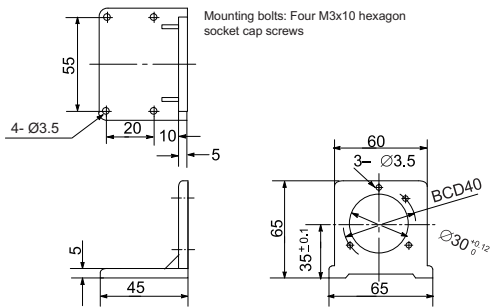

Heavy Duty Incremental Encoders

Features

A heavy-duty encoder is the most rugged encoder you can buy. Top-of-the-line bearings allow a service life of 12 billion revolutions. Features include:

- 10 mm standard shaft
- Rugged body with 78 mm diameter and 60 mm depth
- Splash-proof IP65 rating
- Incremental operation from 30 pulses per revolution to 5,000 pulses per revolution
- 100 kHz maximum response frequency
- 10-30 VDC, Totem-pole output



Standard shaft (TRD-GK) model



Heavy Duty Standard Shaft Incremental Encoders				
Model	Price	Pulses per Revolution	Input Voltage	Output
TRD-GK30-RZD	<--->	30	10-30 VDC	Totem-pole (sink/source)
TRD-GK100-RZD	<--->	100		
TRD-GK120-RZD	<--->	120		
TRD-GK200-RZD	<--->	200		
TRD-GK240-RZD	<--->	240		
TRD-GK250-RZD	<--->	250		
TRD-GK300-RZD	<--->	300		
TRD-GK360-RZD	<--->	360		
TRD-GK400-RZD	<--->	400		
TRD-GK500-RZD	<--->	500		
TRD-GK600-RZD	<--->	600		
TRD-GK800-RZD	<--->	800		
TRD-GK1000-RZD	<--->	1000		
TRD-GK1200-RZD	<--->	1000		
TRD-GK1500-RZD	<--->	1500		
TRD-GK1800-RZD	<--->	1800		
TRD-GK2000-RZD	<--->	2000		
TRD-GK2500-RZD	<--->	2500		
TRD-GK3600-RZD	<--->	3600		
TRD-GK5000-RZD	<--->	5000		

Electrical Specifications		
Model	TRD-GKxxxx-RZD	
Power Supply	Operating Voltage	10 - 30VDC*
	Allowable Ripple	3% rms max.
	Current Consumption	At less than 16VDC: 50 mA max. / at 16VDC or more: 70mA max.
Output Waveform	Output Signal	Two phase + home position
	Duty Ratio	50 ± 25%
	Max. Frequency Response	100kHz max.
	Signal Width at Home Position	At 400P or less: 25 to 150%; at 500P or more: 1° at 30°
	Rise/Fall Time	2µs max. (when cable length is 2m or less)
Output	Output Type	Totem-pole
	Current: Outflow: H	30mA max.
	Voltage: H	(power source voltage - 4V) min.
	Voltage: L	2V max.
	Load Power Voltage	35VDC max.
* To be supplied by Class II source		
Mechanical Specifications		
Starting Torque	Max. 0.1 Nm (.074 ft lbs) max. at 20°C (68°F)	
Max. Allowable Shaft Load	Radial: 100N (22.48 lbs) Axial: 50N (11.24 lbs)	
Max. Allowable Speed	5,000 rpm	
Service Life of Bearing	12 billion revolutions (at max. allowable speed)	
Wire Size	AWG24	
Weight	Approx. 600g (21.16 oz) with 2m cable	
Environmental Specifications		
Ambient Temperature	10 to 70°C; 14 to 158°F	
Storage Temperature	-25 to 85°C; -13 to 185°F	
Operating Humidity	35-85% RH (with no condensation)	
Insulation Resistance	50MΩ min.	
Vibration Resistance	At 500P or less: Durable for one hour along three axes at 10 to 55 Hz with 0.75 mm amplitude At 600P or more: Durable for one hour along three axes at 10 to 55 Hz with 0.35 mm amplitude	
Shock Resistance	At 500P or less: 11 ms with 980 m/s ² applied three times along three axes At 600P or more: 11 ms with 294 m/s ² applied three times along three axes	
Protection	IP65: dust and splash proof	

Heavy Duty Incremental Encoders

Accessories

Couplings

Select a coupling that fits your encoder.
All couplings are in stock, ready to ship.
See page 20-16 for more information.

Mounting bracket

RT-11D metal mounting bracket for all TRD-GK encoders.

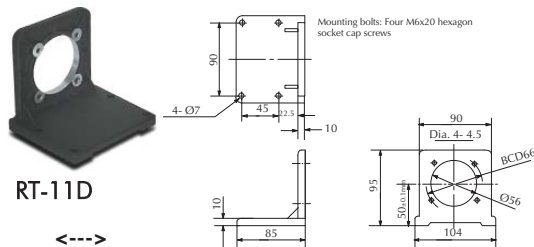

Dimensions

External dimensions

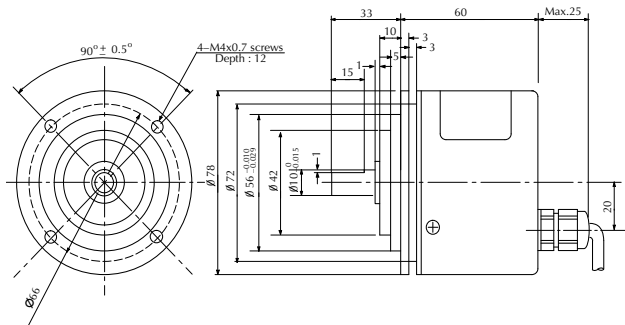

All dimensions in mm 1 mm = 0.03937 in

Servo mounting

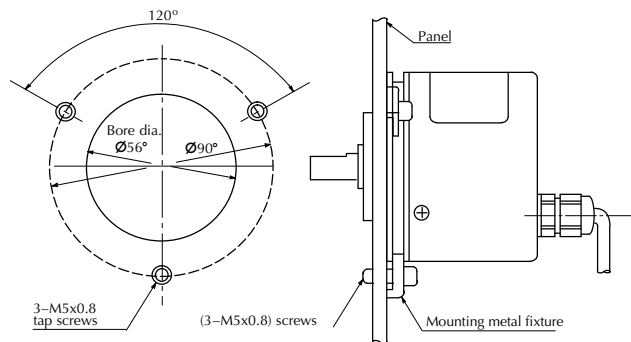

Wiring diagram

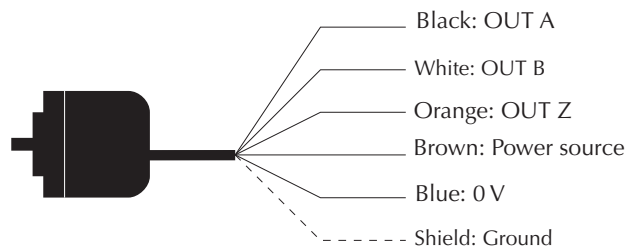

Cable shield is not connected to the encoder body; enclosure is grounded through the 0V wire

Channel timing chart

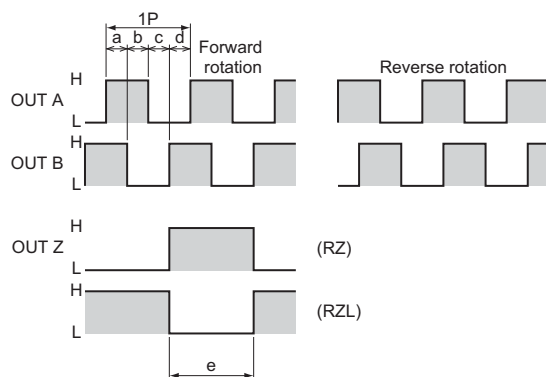

a, b, c, d = (1/4 ± 1/8) P

e: 400 P or less: 25 to 150%

500 P or more: 1 ± 30'

(At 1,800, 3,600, 5000 pulses only: 50 to 150%)

OUT Z generates home position in both directions.

How to read the timing charts

Open Collector Models

Out A and Out B are 90 degrees out of phase. Like any quadrature encoder, four unique logic states are created internal to the encoder. This is based on the rising edge to rising edge (one cycle) on channel A or B that indicates that one set of bars on the internal encoder disk has passed by the optical sensor.

OUT Z is the absolute reference added to an incremental encoder and is also known as home position. It signifies a full rotation of the encoder disk.

Encoder Couplings

Couplings provide a connection between encoders and solid shafts. We offer fiberglass and aluminum metric-to-metric couplings and aluminum metric-to-S.A.E. couplings. Use the selection guide below to help select your coupling.

Couplings Selection Guide and Dimensions														
Type	Part No.	Price	Applicable Encoders	Material	d1	d2	D	L	F	C	M	a	E	S
					mm*									
Fiberglass (metric)	GJ-6D	<--->	TRD-S	Glass-fiber reinforced polyacetal	6	6	15	21.6	5.2	2.8	M3 set screw	6° max.	0.5mm max.	0.12mm max.
	GJ-8D	<--->	TRD-N,-NA		8	8	19	24	6.8	3.5	M4 set screw	5° max.	0.5mm max.	0.12mm max.
	GJ-10D	<--->	TRD-GK		10	10	22	26.2	7.1	3.6	M4 set screw	5° max.	0.5mm max.	0.12mm max.
Aluminum (metric)	RU-075D	<--->	TRD-S	Aluminum alloy	6	6	19.1	19.1	4.8	9.5	M3 set screw	5° max.	0.25mm max.	0.12mm max.
	JU-100D	<--->	TRD-N,-NA		8	8	25.4	25.4	6.9	3.8	M5 set screw	5° max.	0.25mm max.	0.12mm max.
	RU-100D	<--->	TRD-GK		10	10	25.4	25.4	6.9	3.8	M5 set screw	5° max.	0.25mm max.	0.12mm max.
Aluminum (metric to SAE)	MCGL16-6-635	<--->	TRD-S	Aluminum alloy (Bent plate: Polyimide)	6	6.35 (0.25")	16	23.2	7	3	M3 set screw	3.5° max.	0.3mm max.	0.3mm max.
	MCGL20-8-635	<--->	TRD-N,-NA		8	6.35 (0.25")	20	26	7.5	3.7	M3 set screw	3.5° max.	0.3mm max.	0.4mm max.
	MCGL20-8-952	<--->	TRD-N,-NA		8	9.52 (0.375")	20	26	7.5	3.7	M3 set screw	3.5° max.	0.3mm max.	0.4mm max.
	MCGL25-10-635	<--->	TRD-GK		10	6.35 (0.25")	25	30.2	9	4	M4 set screw	3.5° max.	0.3mm max.	0.5mm max.
	MCGL25-10-952	<--->	TRD-GK		10	9.52 (0.375")	25	30.2	9	4	M4 set screw	3.5° max.	0.3mm max.	0.5mm max.

* mm ÷ 25.4 = inches

GJ-6D, GJ-8D, and GJ-10D fiberglass couplings

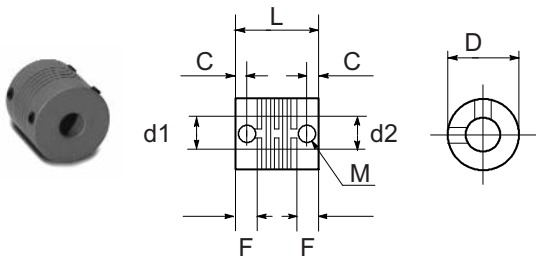

MCGLxx aluminum couplings

Bent plate: polyimide

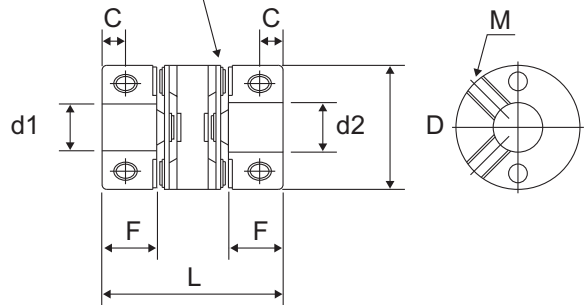

RS-075D, RS-100D, and JU-100D aluminum couplings

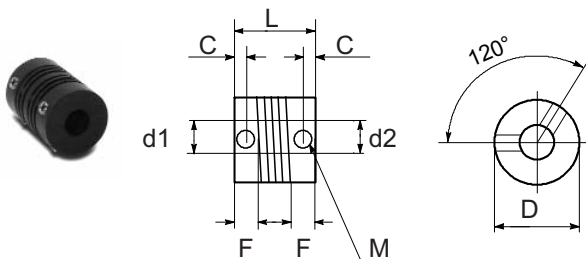

Misalignment compensation

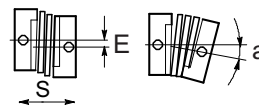

Encoders Frequently Asked Questions

Q: What is a differential line output?

A: Differential output refers to the fact that each channel has a complement channel, i.e. Channel A and Channel A not. A differential line driver is used to help increase noise immunity. It also allows you to sink or source more current than a Totem-pole output. A differential line driver will work with either a sinking or sourcing circuit. It can also help in increasing the distance that a signal is transmitted.

Q: What is an open collector output?

A: An open collector output is an NPN transistor. An NPN transistor allows the sinking of current to common. It can be thought of as a switch that allows the circuit to be connected to common after the load. This means that a source is required for the output to work. A supply through a load must be connected to the output, otherwise the NPN transistor is simply creating a path to common, (i.e., a dry contact). Therefore, if you were to measure the voltage at the output of an open collector that is not connected to some supply, you would not see a change in voltage. The voltage should be measured across the output load to determine if the open collector is working properly.

Q: What is a Totem-pole output?

A: A Totem-pole output, sometimes referred to as a push-pull output, is a bipolar output with active devices that are controlled such that, as the resistance of one increases, the resistance of the other decreases; so that according to the relative states of the two active devices, the output voltage can swing between levels approaching the two supply voltages. The term 'totem-pole output,' as commonly used, does not include three-state outputs.

Q: What is a quadrature output?

A: Quadrature output refers to the use of two output channels (A and B) separated by 90 degrees of phase shift. The fact that the signals are 90 degrees out of phase allows a controller to determine the direction of rotation, i.e. if channel A leads B then the encoder is spinning one direction, if B leads A then the other. See the channel timing charts for a graphical view of this concept. Remember that each channel

provides the rated PPR for each encoder. For example: with a 100 PPR encoder, there are 100 pulses per revolution from channel A, and 100 pulses from channel B. This is a total of 200 pulses if your controller can count both channels (X2 logic). Some controllers can count the rising edge and the falling edge of each pulse (on both channels) thereby increasing the effective resolution by a factor of four (X4 logic), and counting 400 edges per revolution on a 100 PPR quadrature encoder. This doesn't mean that there are 400 pulses coming from a 100 PPR quadrature encoder.

Q: Why do I need a pull-up resistor?

A: A pull-up resistor is used to *pull* the logic high voltage level up to the level of the operating voltage. This is useful when the output of the open collector is not reaching the voltage level needed to indicate a logic high signal or when noise is present on the signal line. When a logic high signal is present, its voltage level will be approximately that of the operating voltage for an open circuit. The difference is due to the voltage drop across the pull-up resistor. This is not necessarily true if the load is referenced to ground. Pull-up resistors are also used to convert sinking devices to sourcing devices, which inverts the pulse train.

Q: What is the difference between X2 and X4 logic?

A: Some devices that are commonly interfaced to encoders (controllers, counters, displays) can detect more events per revolution than the rated PPR output of a quadrature encoder signal. Because a quadrature encoder provides two channels of pulses, a controller that counts the pulses on both channels can count twice (X2) the PPR output of a given encoder. For example, a controller with X2 logic can count 240 pulses per rev. from a 120 PPR encoder. Some controllers can count the rising edge and the falling edge of each pulse (on both channels) thereby counting four times (X4) the PPR rating of the encoder (or 480 edges per revolution in our example). It's important to remember that a quadrature encoder produces two channels of pulses at a given PPR. X2 or X4 logic refers to how the controller (or other device) interprets those pulse streams.

Q: Is shielded cable needed?

A: YES. The use of shielded cable is highly recommended. This is especially true for areas in which large amounts of electrical noise exist. If you are having any noise problems, or suspect that you might, then use a shielded cable.

Q: How do I set my calibration constant?

A: The calibration constant can be simplified by selecting the correct pulses per revolution (PPR). When choosing your calibration constant, remember: the closer to 1, the better. The value of the calibration constant is your best resolution per pulse of the encoder.

Q: How do I choose the pulses per revolution (PPR)?

A: When choosing the PPR value of the encoder, you should follow a few simple rules. Make sure that you do not choose a PPR that will exceed the maximum input frequency of the controller (or whatever device the encoder is driving). To calculate the max frequency of the encoder signal (in Hz): simply multiply the speed that the encoder will spin (in revs/sec) by the PPR of the encoder (don't forget to take X2 or X4 logic into account if it applies for your application). Try to choose a PPR that is an even multiple of the value you are trying to measure or display. For example, if one revolution of the encoder equates to 12 inches of travel, you might choose a 1200 PPR encoder. This can eliminate or simplify the need for a calibration constant or scaling factor and more importantly, it eliminates the possibility of accumulating a rounding error over many cycles of the encoder. In this example you would be able to measure the travel to a resolution of 1/100 of an inch. You should also consider any 2x or 4x counting logic in your controller. If your controller can "see" pulses on both the A and B channels (2x logic), then it will count 2400 pulses for every 12 inches of travel in our example. If the controller counts both the leading edge and the trailing edge of each of the pulses on both channels (4x logic), then it will count 4800 edges per revolution and your effective resolution would increase to 1/400 of an inch per count.

FAQs continued on next page

Encoders Frequently Asked Questions

Q: How accurate will an encoder be in my application?

A: Encoders can provide a very accurate indication of rotational position, but it's impossible to say how accurate a given encoder will be in a real-world application. Mechanical inaccuracies and electrical issues such as noise, or lost counts can affect the accuracy of any system. A good rule of thumb is to design the system to measure from 2 to 5 times more resolution than your desired accuracy. For example: if you wish to accurately measure movement of 1/100th of an inch, you should select an encoder that can deliver at least 200 counts per inch of resolution. In a rotary application - if you need accuracy within 6 degrees, select an encoder that can deliver at least 120 counts per revolution (a resolution of 3 degrees) to your controller.

Q: How far away can I place my encoder from my system?

A: There is no set answer to this question. Many factors play a role in determining the maximum length of cable that can be used to connect the units together. The largest problem with running long lengths of cable is that the cable becomes more susceptible to noise. This is due to the capacitance of the cable, the cable acting as an antenna, and the loss of power through the cable. The maximum distance of cable can be achieved by following some basic wiring principles. Do not run the cable near objects that create a lot of electrical noise. This includes AC motors, arc welders, AC power lines, and transformers. Use twisted pair cabling when using the signal and its compliment, and shielded cabling when running any type of signal. Use the highest voltage available for the output voltage. For example, if the encoder will output 5 to 24 volts, then use 24 volts. Use an open collector or differential line driver output with a differential receiver so that the maximum amount of current can be sink/sourced. If you are using the encoder as an input to more than one controller, use a signal amplifier. This is also a good way to help increase the distance a signal can travel. Typical maximum distances for a differential line driver are around 100ft., or more when using a differential input, and for an open collector the distance is around 35 ft.

Q: Why use an absolute encoder?

A: An absolute encoder has each position of the revolution uniquely numbered. This means that instead of an output of pulses, you get an output that is a specific value in a binary format. This is very useful when exact positioning is a must. If the power should be lost, the actual value of the position will be known when power is restored, since each location in an absolute encoder's revolution is a unique binary value. The exact position will be known even if the controller loses power and the process is moved.

Q: What is gray code?

A: Gray code is a form of binary. The difference between gray code and binary is the method of incrementing to the next number. In gray code, only one digit may change states for every increment. This means the count sequence would look something like this: 0, 1, 3, 2, 6, and 7. This is different than standard binary, where the sequence would be 0,1, 2, 3, 4, and 5.

Gray code is used to prevent errors as transitions to the next state occur. An example of how an error could occur would be when both values in the sequence were true. This can occur due to the timing sequence and the capacitance of the cable. The transition from 0011 to 0100 could cause 0111 to be generated. With gray code this is not possible.

Q: How do I convert gray code to binary?

A: The conversion from gray code to binary is simple.

Step 1: Write the number down and copy the left most digit under itself.

Step 2: Add the highlighted binary digit to the gray code immediately up and to the right of it. So, 1 plus 1 is 0 dropping the carried digit. Write the result next to the binary digit just added. Drop all of the carried digits.

Step 3: Repeat Step 2 until the number is completed.

Q: What is a sinking or sourcing Input?

A: Sinking and sourcing inputs simply refer to the current flow in a transistor. This means that they require a voltage and a load to operate. A sinking input requires the voltage and load to be present before connecting it to the circuit. This means that it is "sinking" the current to ground for the circuit. A sourcing input must be before the load in the circuit. This means that it is "sourcing" the current to the circuit. Voltage and a load must be present in either case to detect a voltage change at the input. The same is true for sinking or sourcing outputs.