

AutomationDirect Controllers and ZILinks



Modules



Feedthrough Connector Modules

ZL-RTB20

ZL-RTB40

ZL-RTB50

Feedthrough modules provide low-cost and compact field wiring screw termination solutions for quickly connecting Link cables with PLCs.



Fuse Modules

ZL-RFU20

ZL-RFU40

Fuse modules provide fuse protection for PLC output devices. The 16 and 32-point fuse modules include replaceable fuses and protective safety covers.

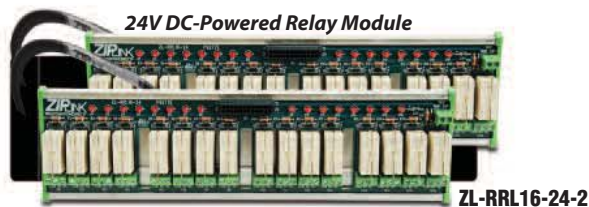

24V DC-Powered Relay Module

ZL-RRL16-24-1 (sink and source models available)

Our DC-powered relay module provides isolation, switches high current (10A) loads, is offered in 16 points, and includes diode protection to prevent voltage spikes at the relay coil from damaging connected PLC I/O

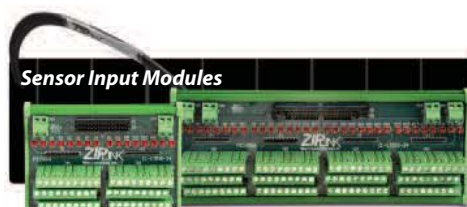

Sensor Input Modules

ZL-LTB16-24

ZL-LTB32-24

LED modules provide simple and logical termination for 3-wire sensors or other devices. These modules offer visual LED indication of device input status for quick troubleshooting. The LED/sensor modules are available in 16 and 32-point versions.



Relays included

24VDC Stand-Alone Relay Modules

ZL-RLS1-24

ZL-RLS4-24

24 VDC stand-alone relay modules use plug-in relays for switching high current (10A) loads.



Relays included

120VAC Stand-Alone Relay Modules

ZL-RLS1-12

ZL-RLS4-120

120 VAC Stand alone relay modules use plug-in relays for switching high current (10A) loads.



D-Sub Feedthrough Modules

ZL-RTB-DB09

ZL-RTB-DB25

ZL-RTB-DB15

These connector modules provide a fast and convenient method of transitioning between D-Sub connectors and field wiring devices.



RJ12 Feedthrough Module

ZL-RTB-RJ12

The RJ12 feedthrough module provides convenient break-out of wiring to terminal blocks.

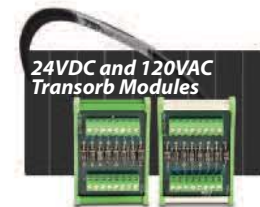

24VDC and 120VAC Transorb Modules

ZL-TSD8-24 ZL-TSD8-120

8-channel devices used to suppress counter-electromotive force (CEMF) generated by switching inductive loads which can cause unexpected PLC system shutdown.



Communication Distribution Modules

ZL-CDM-RJ12X4 ZL-CDM-RJ12X10

The RJ12 multi-port distribution modules allow for fast and convenient RS485 multi-drop connections.



Communications Port Adapters

ZL-CMA15L ZL-CMA15

Communication adaptors eliminate the hassle associated with connecting crimp or solder connectors to PLC communication ports.

Modules mount on 35 mm DIN rail part # DN-R35S1.

See Accessories in previous Terminal Blocks section

Cables

- Pre-wired • Ready-to-wire • D-Subminiature • and more!

ZILink cables are available in a number of pre-wired and ready-to-wire configurations that accommodate the majority of our **DirectLOGIC** and **CLICK** PLC discrete I/O modules.



Wiring Solutions using the ZIPLink Wiring System

ZIPLinks eliminate the normally tedious process of wiring between devices by utilizing prewired cables and DIN rail mount connector modules. It's as simple as plugging in a cable connector at either end or terminating wires at only one end. Prewired cables keep installation clean and efficient, using half the space at a fraction of the cost of standard terminal blocks. There are several wiring solutions available when using the ZIPLink System ranging from PLC I/O-to-ZIPLink Connector Modules that are ready for field termination, options for connecting to third party devices, GS, DuraPulse and SureServo Drives, and specialty relay, transorb and communications modules. Pre-printed I/O-specific adhesive label strips for quick marking of ZIPLink modules are provided with ZIPLink cables. See the following solutions to help determine the best ZIPLink system for your application.

Solution 1: DirectLOGIC, CLICK and Productivity3000 I/O Modules to ZIPLink Connector Modules

When looking for quick and easy I/O-to-field termination, a ZIPLink connector module used in conjunction with a prewired ZIPLink cable, consisting of an I/O terminal block at one end and a multi-pin connector at the other end, is the best solution.



Using the PLC I/O Modules to ZIPLink Connector Modules selector tables located in this section,

1. Locate your I/O module/PLC.
2. Select a ZIPLink Module.
3. Select a corresponding ZIPLink Cable.

Solution 2: DirectLOGIC, CLICK and Productivity3000 I/O Modules to 3rd Party Devices

When wanting to connect I/O to another device within close proximity of the I/O modules, no extra terminal blocks are necessary when using the ZIPLink Pigtail Cables. ZIPLink Pigtail Cables are prewired to an I/O terminal block with color-coded pigtail with soldered-tip wires on the other end.



Using the I/O Modules to 3rd Party Devices selector tables located in this section,

1. Locate your PLC I/O module.
2. Select a ZIPLink Pigtail Cable that is compatible with your 3rd party device.

Solution 3: GS Series and DuraPulse Drives Communication Cables

Need to communicate via Modbus RTU to a drive or a network of drives?

ZIPLink cables are available in a wide range of configurations for connecting to PLCs and SureServo, SureStep, Stellar Soft Starter and AC drives. Add a ZIPLink communications module to quickly and easily set up a multi-device network.

Using the Drives Communication selector tables located in this section,

1. Locate your Drive and type of communications.
2. Select a ZIPLink cable and other associated hardware.



Solution 4: Serial Communications Cables

ZIPLink offers communications cables for use with *Direct*LOGIC, CLICK, and Productivity3000 CPUs, that can also be used with other communications devices. Connections include a 6-pin RJ12 or 9-pin, 15-pin and 25-pin D-sub connectors which can be used in conjunction with the RJ12 or D-Sub Feedthrough modules.

Using the **Serial Communications Cables** selector table located in this section,

1. Locate your connector type
2. Select a cable.



Solution 5: Specialty ZIPLink Modules

For additional application solutions, ZIPLink modules are available in a variety of configurations including stand-alone relays, 24VDC and 120VAC transorb modules, D-sub and RJ12 feedthrough modules, communication port adapter and distribution modules, and SureServo 50-pin I/O interface connection.

Using the **ZIPLink Specialty Modules** selector table located in this section,

1. Locate the type of application.
2. Select a ZIPLink module.



Solution 6: ZIPLink Connector Modules to 3rd Party Devices

If you need a way to connect your device to terminal blocks without all that wiring time, then our pigtail cables with color-coded soldered-tip wires are a good solution. Used in conjunction with any compatible ZIPLink Connector Modules, a pigtail cable keeps wiring clean and easy and reduces troubleshooting time.

Using the **Universal Connector Modules and Pigtail Cables** table located in this section,

1. Select module type.
2. Select the number of pins.
3. Select cable.



PLC I/O Modules to ZIPLink Connector Modules - CLICK

| CLICK PLC Input Module ZIPLink Selector | | | | |
|---|------------|-------------|-----------------|----------------|
| PLC | | ZIPLink | | |
| Input Module | # of Terms | Component | Module Part No. | Cable Part No. |
| CO-08ND3 | 11 | Feedthrough | ZL-RTB20 | ZL-CO-CBL11* |
| CO-08ND3-1 | 11 | Feedthrough | ZL-RTB20 | ZL-CO-CBL11* |
| CO-08NE3 | 11 | Feedthrough | ZL-RTB20 | ZL-CO-CBL11* |
| CO-08NA | 11 | Feedthrough | ZL-RTB20 | ZL-CO-CBL11* |
| CO-16ND3 | 20 | Feedthrough | ZL-RTB20 | ZL-CO-CBL20* |
| | | Sensor | ZL-LTB16-24 | ZL-CO-CBL20* |
| CO-16NE3 | 20 | Feedthrough | ZL-RTB20 | ZL-CO-CBL20* |
| | | Sensor | ZL-LTB16-24 | ZL-CO-CBL20* |

| CLICK PLC Combo In/Out Module ZIPLink Selector | | | | |
|--|------------|-------------|-----------------|----------------|
| PLC | | ZIPLink | | |
| Combo Module | # of Terms | Component | Module Part No. | Cable Part No. |
| CO-00DD1-D | 20 | Feedthrough | ZL-RTB20 | ZL-CO-CBL20* |
| CO-00DD2-D | 20 | Feedthrough | ZL-RTB20 | ZL-CO-CBL20* |
| CO-00DR-D | 20 | Feedthrough | ZL-RTB20 | ZL-CO-CBL20* |
| CO-00AR-D | 20 | Feedthrough | ZL-RTB20 | ZL-CO-CBL20* |
| CO-01DD1-D | 20 | Feedthrough | ZL-RTB20 | ZL-CO-CBL20* |
| CO-01DD2-D | 20 | Feedthrough | ZL-RTB20 | ZL-CO-CBL20* |
| CO-01DR-D | 20 | Feedthrough | ZL-RTB20 | ZL-CO-CBL20* |
| CO-01AR-D | 20 | Feedthrough | ZL-RTB20 | ZL-CO-CBL20* |



NOTE: ZIPLINK CONNECTOR MODULES SPECIFICATIONS FOLLOW THE COMPATIBILITY MATRIX TABLES. ZIPLINK CABLES SPECIFICATIONS ARE AT THE END OF THIS ZIPLINK SECTION.

| CLICK PLC Output Module ZIPLink Selector | | | | |
|--|------------|------------------|-----------------------|----------------|
| PLC | | ZIPLink | | |
| Output Module | # of Terms | Component | Module Part No. | Cable Part No. |
| CO-08TD1 | 11 | Feedthrough | ZL-RTB20 | ZL-CO-CBL11* |
| CO-08TD2 | 11 | Feedthrough | ZL-RTB20 | ZL-CO-CBL11* |
| CO-08TR | 11 | Feedthrough | ZL-RTB20 | ZL-CO-CBL11* |
| CO-08TA | 11 | Feedthrough | ZL-RTB20 | ZL-CO-CBL11* |
| CO-16TD1 | 20 | Feedthrough | ZL-RTB20 | ZL-CO-CBL20* |
| | | Fuse | ZL-RFU20 ² | ZL-CO-CBL20* |
| | | Relay (sinking) | ZL-RRL16-24-1 | ZL-CO-CBL20* |
| CO-16TD2 | 20 | Feedthrough | ZL-RTB20 | ZL-CO-CBL20* |
| | | Fuse | ZL-RFU20 ² | ZL-CO-CBL20* |
| | | Relay (sourcing) | ZL-RRL16-24-2 | ZL-CO-CBL20* |
| CO-04TRS ¹ | 20 | Feedthrough | ZL-RTB20 | ZL-CO-CBL20* |

* Select the cable length by replacing the * with: Blank = 0.5m, -1 = 1.0m, or -2 = 2.0m.

¹ Note: The CO-04TRS relay output is derated not to exceed 2A per point max. when used with the ZIPLink wiring system.

² Note: Fuses (5 x 20 mm) are not included. See Edison Electronic Fuse section for (5 x 20 mm) fuse. S500 and GMA electronic circuit protection for fast-acting maximum protection. S506 and GMC electronic circuit protection for time-delay performance. Ideal for inductive circuits. To ensure proper operation, do not exceed the voltage and current rating of ZIPLink module. ZL-RFU20 = 2A per circuit; ZL-RFU40 = 400 mA per circuit.



PLC I/O Modules to ZIPLink Connector Modules - DL05/06

| DL05/06 PLC Input Module ZIPLink Selector | | | | |
|---|------------|-------------|-----------------|----------------|
| PLC | | ZIPLink | | |
| Input Module | # of Terms | Component | Module Part No. | Cable Part No. |
| DO-10ND3 | 13 | Feedthrough | ZL-RTB20 | ZL-D0-CBL13* |
| DO-10ND3F | 13 | Feedthrough | ZL-RTB20 | ZL-D0-CBL13* |
| DO-16ND3 | 24 | Feedthrough | ZL-RTB20 | ZL-D0-CBL24*L |
| | | Sensor | ZL-LTB16-24 | ZL-D0-CBL24*L |
| FO-08NA-1 | 10 | Feedthrough | ZL-RTB20 | ZL-D0-CBL10* |

| DL05/06 PLC Combo In/Out Module ZIPLink Selector | | | | |
|--|------------|-------------|-----------------|----------------|
| PLC | | ZIPLink | | |
| Combo Module | # of Terms | Component | Module Part No. | Cable Part No. |
| DO-07CDR | 10 | Feedthrough | ZL-RTB20 | ZL-D0-CBL10* |
| DO-08CDD1 | 13 | Feedthrough | ZL-RTB20 | ZL-D0-CBL13* |

| DL05/06 PLC Analog Module ZIPLink Selector | | | | |
|--|--------------|-------------|------------|--------------|
| PLC | | ZIPLink | | |
| Analog Module | # of Terms | Component | Module | Cable |
| FO-04AD-1 | 8 | Feedthrough | ZL-RTB20 | ZL-D0-CBL8* |
| FO-04AD-2 | 8 | Feedthrough | ZL-RTB20 | ZL-D0-CBL8* |
| FO-08ADH-1 | 13 | Feedthrough | ZL-RTB20 | ZL-D0-CBL13* |
| FO-08ADH-2 | 13 | Feedthrough | ZL-RTB20 | ZL-D0-CBL13* |
| FO-04DAH-1 | 13 | Feedthrough | ZL-RTB20 | ZL-D0-CBL13* |
| FO-08DAH-1 | 13 | Feedthrough | ZL-RTB20 | ZL-D0-CBL13* |
| FO-04DAH-2 | 13 | Feedthrough | ZL-RTB20 | ZL-D0-CBL13* |
| FO-08DAH-2 | 13 | Feedthrough | ZL-RTB20 | ZL-D0-CBL13* |
| FO-2AD2DA-2 | 8 | Feedthrough | ZL-RTB20 | ZL-D0-CBL8* |
| FO-4AD2DA-1 | 8 | Feedthrough | ZL-RTB20 | ZL-D0-CBL8* |
| FO-4AD2DA-2 | 8 | Feedthrough | ZL-RTB20 | ZL-D0-CBL8* |
| FO-04RTD ² | Matched Only | | See Note 2 | |
| FO-04THM ² | Matched Only | | See Note 2 | |



NOTE: ZIPLINK CONNECTOR MODULES SPECIFICATIONS FOLLOW THE COMPATIBILITY MATRIX TABLES. ZIPLINK CABLES SPECIFICATIONS ARE AT THE END OF THIS ZIPLINK SECTION.

| DL05/06 PLC Output Module ZIPLink Selector | | | | |
|--|------------|------------------|-----------------------|----------------|
| PLC | | ZIPLink | | |
| Output Module | # of Terms | Component | Module Part No. | Cable Part No. |
| DO-10TD1 | 13 | Feedthrough | ZL-RTB20 | ZL-D0-CBL13* |
| DO-16TD1 | 24 | Feedthrough | ZL-RTB20 | ZL-D0-CBL24* |
| | | Fuse | ZL-RFU20 ³ | ZL-D0-CBL24* |
| | | Relay (sinking) | ZL-RRL16-24-1 | ZL-D0-CBL24* |
| DO-10TD2 | 13 | Feedthrough | ZL-RTB20 | ZL-D0-CBL13* |
| DO-16TD2 | 24 | Feedthrough | ZL-RTB20 | ZL-D0-CBL24* |
| | | Fuse | ZL-RFU20 ³ | ZL-D0-CBL24* |
| | | Relay (sourcing) | ZL-RRL16-24-2 | ZL-D0-CBL24* |
| DO-08TR | 10 | Feedthrough | ZL-RTB20 | ZL-D0-CBL10* |
| FO-04TRS ¹ | 13 | Feedthrough | ZL-RTB20 | ZL-D0-CBL13* |

| DL05/06 PLC Fixed I/O ZIPLink Selector | | | | |
|--|-----------------------|-------------|-----------------|----------------|
| PLC | | ZIPLink | | |
| PLC | # of Terms | Component | Module Part No. | Cable Part No. |
| DL05 | 18 | Feedthrough | ZL-RTB20 | ZL-D05-CBL18* |
| DL06** | 20 (Input side only) | Feedthrough | ZL-RTB20 | ZL-D06X-CBL20* |
| | 20 (Output side only) | Feedthrough | ZL-RTB20 | ZL-D06Y-CBL20* |

* Select the cable length by replacing the * with: Blank = 0.5m, -1 = 1.0m, or -2 = 2.0m.

** Inputs side only connects X0 through X17. X20 thru X23 will have to be hand wired if used. Output side the power and auxiliary power terminals will have to be hand wired.

¹ Caution: The FO-04TRS relay outputs are derated not to exceed 2A per point when used with the ZIPLink wiring system.

² These modules are not supported by the ZIPLink wiring system.

³ Note: Fuses (5 x 20 mm) are not included. See Edison Electronic Fuse section for (5 x 20 mm) fuse. S500 and GMA electronic circuit protection for fast-acting maximum protection. S506 and GMC electronic circuit protection for time-delay performance. Ideal for inductive circuits. To ensure proper operation, do not exceed the voltage and current rating of ZIPLink module. ZL-RFU20 = 2A per circuit; ZL-RFU40 = 400 mA per circuit.



PLC I/O Modules to ZIPLink Connector Modules - DL205

| DL205 PLC Input Module ZIPLink Selector | | | | |
|---|------------|-------------|-----------------|------------------|
| PLC | | ZIPLink | | |
| Input Module | # of Terms | Component | Module Part No. | Cable Part No. † |
| D2-08ND3 | 10 | Feedthrough | ZL-RTB20 | ZL-D2-CBL10* |
| D2-16ND3-2 | 19 | Feedthrough | ZL-RTB20 | ZL-D2-CBL19* |
| | | Sensor | ZL-LTB16-24 | ZL-D2-CBL19* |
| D2-32ND3 ¹ | 40 | Feedthrough | ZL-RTB40 | ZL-D24-CBL40* |
| | | | ZL-RTB40 | ZL-D24-CBL40*X |
| | | Sensor | ZL-LTB32-24 | ZL-D24-CBL40* |
| | | | ZL-LTB32-24 | ZL-D24-CBL40*X |
| D2-32ND3-2 ¹ | 40 | Feedthrough | ZL-RTB40 | ZL-D24-CBL40* |
| | | Sensor | ZL-LTB32-24 | ZL-D24-CBL40* |
| D2-08NA-1 | 10 | Feedthrough | ZL-RTB20 | ZL-D2-CBL10* |
| D2-08NA-2 | 10 | Feedthrough | ZL-RTB20 | ZL-D2-CBL10* |
| D2-16NA | 19 | Feedthrough | ZL-RTB20 | ZL-D2-CBL19* |

† X in the part number represents a 45° angle.

| DL205 PLC Combo In/Out Module ZIPLink Selector | | | | |
|--|------------|-------------|-----------------|----------------|
| PLC | | ZIPLink | | |
| Combo Module | # of Terms | Component | Module Part No. | Cable Part No. |
| D2-08CDR | 10 | Feedthrough | ZL-RTB20 | ZL-D2-CBL10* |

| DL205 PLC Analog Module ZIPLink Selector | | | | |
|--|--------------|-------------|------------|--------------|
| PLC | | ZIPLink | | |
| Analog Module | # of Terms | Component | Module | Cable |
| F2-04AD-1 | 10 | Feedthrough | ZL-RTB20 | ZL-D2-CBL10* |
| F2-04AD-1L | 10 | Feedthrough | ZL-RTB20 | ZL-D2-CBL10* |
| F2-08AD-1 | 10 | Feedthrough | ZL-RTB20 | ZL-D2-CBL10* |
| F2-04AD-2 | 10 | Feedthrough | ZL-RTB20 | ZL-D2-CBL10* |
| F2-04AD-2L | 10 | Feedthrough | ZL-RTB20 | ZL-D2-CBL10* |
| F2-08AD-2 | 10 | Feedthrough | ZL-RTB20 | ZL-D2-CBL10* |
| F2-02DA-1 | 10 | Feedthrough | ZL-RTB20 | ZL-D2-CBL10* |
| F2-02DA-1L | 10 | Feedthrough | ZL-RTB20 | ZL-D2-CBL10* |
| F2-02DA-1 | 10 | Feedthrough | ZL-RTB20 | ZL-D2-CBL10* |
| F2-02DA-2 | 10 | Feedthrough | ZL-RTB20 | ZL-D2-CBL10* |
| F2-02DA-2L | 10 | Feedthrough | ZL-RTB20 | ZL-D2-CBL10* |
| F2-02DAS-2 | 10 | Feedthrough | ZL-RTB20 | ZL-D2-CBL10* |
| F2-08DA-2 | 10 | Feedthrough | ZL-RTB20 | ZL-D2-CBL10* |
| F2-4AD2DA | 10 | Feedthrough | ZL-RTB20 | ZL-D2-CBL10* |
| F2-8AD4DA-1 | 19 | Feedthrough | ZL-RTB20 | ZL-D2-CBL19* |
| F2-8AD4DA-2 | 19 | Feedthrough | ZL-RTB20 | ZL-D2-CBL19* |
| F2-04RTD ⁴ | Matched Only | | See Note 4 | See Note 4 |
| F2-04THM ⁴ | Matched Only | | See Note 4 | See Note 4 |



| DL205 PLC Output Module ZIPLink Selector | | | | |
|--|------------|-------------|-----------------------|------------------|
| PLC | | ZIPLink | | |
| Output Module | # of Terms | Component | Module Part No. | Cable Part No. † |
| D2-04TD1 ² | 10 | Feedthrough | ZL-RTB20 | ZL-D2-CBL10* |
| D2-08TD1 | 10 | Feedthrough | ZL-RTB20 | ZL-D2-CBL10* |
| D2-08TD2 | 10 | Feedthrough | ZL-RTB20 | ZL-D2-CBL10* |
| D2-16TD1-2 | 19 | Feedthrough | ZL-RTB20 | ZL-D2-CBL19* |
| | | Fuse | ZL-RFU20 ⁵ | ZL-D2-CBL19* |
| | | Relay | ZL-RRL16-24-1 | ZL-D2-CBL19* |
| D2-16TD2-2 | 19 | Feedthrough | ZL-RTB20 | ZL-D2-CBL19* |
| | | Fuse | ZL-RFU20 ⁵ | ZL-D2-CBL19* |
| | | Relay | ZL-RRL16-24-2 | ZL-D2-CBL19* |
| F2-16TD1P | 19 | Feedthrough | ZL-RTB20 | ZL-D2-CBL19* |
| | | Relay | ZL-RRL16-24-1 | ZL-D2-CBL19* |
| F2-16TD2P | 19 | Feedthrough | ZL-RTB20 | ZL-D2-CBL19* |
| | | Relay | ZL-RRL16-24-2 | ZL-D2-CBL19* |
| D2-32TD1 ¹ | 40 | Feedthrough | ZL-RTB40 | ZL-D24-CBL40* |
| | | Fuse | ZL-RFU40 ⁵ | ZL-D24-CBL40* |
| | | Fuse | ZL-RFU40 ⁵ | ZL-D24-CBL40*X |
| D2-32TD2 ¹ | 40 | Feedthrough | ZL-RTB40 | ZL-D24-CBL40* |
| | | Fuse | ZL-RFU40 ⁵ | ZL-D24-CBL40* |
| | | Fuse | ZL-RFU40 ⁵ | ZL-D24-CBL40*X |
| D2-08TA | 10 | Feedthrough | ZL-RTB20 | ZL-D2-CBL10* |
| F2-08TA | 10 | Feedthrough | ZL-RTB20 | ZL-D2-CBL10* |
| D2-12TA | 19 | Feedthrough | ZL-RTB20 | ZL-D2-CBL19* |
| | | Fuse | ZL-RFU20 ⁵ | ZL-D2-CBL19* |
| D2-04TRS ² | 10 | Feedthrough | ZL-RTB20 | ZL-D2-CBL10* |
| D2-08TR | 10 | Feedthrough | ZL-RTB20 | ZL-D2-CBL10* |
| F2-08TRS ² | 19 | Feedthrough | ZL-RTB20 | ZL-D2-CBL19* |
| F2-08TR ³ | 10 | Feedthrough | ZL-RTB20 | ZL-D2-CBL10* |
| D2-12TR | 19 | Feedthrough | ZL-RTB20 | ZL-D2-CBL19* |
| | | Fuse | ZL-RFU20 ⁵ | ZL-D2-CBL19* |

† X in the part number represents a 45° angle plug

* Select the cable length by replacing the * with: Blank = 0.5m, -1 = 1.0m, or -2 = 2.0m.

¹ To make a custom cable for the 32-point modules, use: Ribbon-style Connector ZL-D24-CON-R, Solder-style 180° connector ZL-D24-CON or Solder-style 45° connector ZL-D24-CON-X

² Caution: The D2-04TD1, D2-04TRS, and F2-08TRS outputs are derated not to exceed module specs 2A per point and 2A per common when used with the ZIPLink wiring system.

³ The F2-08TR outputs are derated not to exceed 2A per point and 4A per common when used with the ZIPLink wiring system.

⁴ The F2-04RTD and F2-04THM modules are not supported by the ZIPLink wiring system.

⁵ Note: Fuses (5 x 20 mm) are not included. See Edison Electronic Fuse section for (5 x 20 mm) fuse. S500 and GMA electronic circuit protection for fast-acting maximum protection. S506 and GMC electronic circuit protection for time-delay performance. Ideal for inductive circuits.

To ensure proper operation, do not exceed the voltage and current rating of ZIPLink module. ZL-RFU20 = 2A per circuit; ZL-RFU40 = 400 mA per circuit.



NOTE: ZIPLINK CONNECTOR MODULES SPECIFICATIONS FOLLOW THE COMPATIBILITY MATRIX TABLES. ZIPLINK CABLES SPECIFICATIONS ARE AT THE END OF THIS ZIPLINK SECTION.

PLC I/O Modules to ZIPLink Connector Modules - DL305

| DL305 PLC Input Module ZIPLink Selector | | | | |
|---|------------|-------------|-----------------|----------------|
| PLC | | ZIPLink | | |
| Input Module | # of Terms | Component | Module Part No. | Cable Part No. |
| D3-08ND2 ¹ | 10 | See Note 1 | | |
| D3-16ND2-1 | 18 | Feedthrough | ZL-RTB20 | ZL-D3-CBL18* |
| D3-16ND2F | 18 | Feedthrough | ZL-RTB20 | ZL-D3-CBL18* |
| D3-16ND3F | 18 | Feedthrough | ZL-RTB20 | ZL-D3-CBL18* |
| D3-08NA-1 ¹ | 10 | See Note 1 | | |
| D3-08NA-2 ¹ | 10 | See Note 1 | | |
| D3-16NA | 18 | Feedthrough | ZL-RTB20 | ZL-D3-CBL18* |
| D3-08NE3 ¹ | 10 | See Note 1 | | |
| D3-16NE3 | 18 | Feedthrough | ZL-RTB20 | ZL-D3-CBL18* |
| | | Sensor | ZL-LTB16-24 | ZL-D3-CBL18* |

| DL305 PLC Analog Module ZIPLink Selector | | | | |
|--|---------------|-------------|----------|--------------|
| PLC | | ZIPLink | | |
| Analog Module | # of Terms | Component | Module | Cable |
| F3-04ADS | 18 | Feedthrough | ZL-RTB20 | ZL-D3-CBL18* |
| F3-08AD-1 | 18 | Feedthrough | ZL-RTB20 | ZL-D3-CBL18* |
| F3-16AD | 18 | Feedthrough | ZL-RTB20 | ZL-D3-CBL18* |
| F3-04DA-1 | 18 | Feedthrough | ZL-RTB20 | ZL-D3-CBL18* |
| F3-04DAS | 18 | Feedthrough | ZL-RTB20 | ZL-D3-CBL18* |
| F3-08THM-J ³ | T/C Wire Only | See Note 3 | | |
| F3-08THM-K ³ | T/C Wire Only | See Note 3 | | |



NOTE: ZIPLINK CONNECTOR MODULES SPECIFICATIONS FOLLOW THE COMPATIBILITY MATRIX TABLES. ZIPLINK CABLES SPECIFICATIONS ARE AT THE END OF THIS ZIPLINK SECTION.



| DL305 PLC Output Module ZIPLink Selector | | | | |
|--|------------|------------------|-----------------------|----------------|
| PLC | | ZIPLink | | |
| Output Module | # of Terms | Component | Module Part No. | Cable Part No. |
| D3-04TD1 ¹ | 10 | See Note 1 | | |
| D3-08TD1 ¹ | 10 | See Note 1 | | |
| D3-08TD2 ¹ | 10 | See Note 1 | | |
| D3-16TD1-1 | 18 | Feedthrough | ZL-RTB20 | ZL-D3-CBL18* |
| | | Fuse | ZL-RFU20 ⁴ | ZL-D3-CBL18* |
| | | Relay (sinking) | ZL-RRL16-24-1 | ZL-D3-CBL18* |
| D3-16TD2 | 18 | Feedthrough | ZL-RTB20 | ZL-D3-CBL18* |
| | | Fuse | ZL-RFU20 ⁴ | ZL-D3-CBL18* |
| | | Relay (sourcing) | ZL-RRL16-24-2 | ZL-D3-CBL18* |
| D3-04TAS ¹ | 10 | See Note 1 | | |
| F3-08TAS-1 | 18 | Feedthrough | ZL-RTB20 | ZL-D3-CBL18* |
| D3-08TA-1 | 18 | Feedthrough | ZL-RTB20 | ZL-D3-CBL18* |
| D3-08TA-2 ¹ | 10 | See Note 1 | | |
| F3-16TA-2 | 18 | Feedthrough | ZL-RTB20 | ZL-D3-CBL18* |
| | | Fuse | ZL-RFU20 ⁴ | ZL-D3-CBL18* |
| D3-16TA-2 | 18 | Feedthrough | ZL-RTB20 | ZL-D3-CBL18* |
| | | Fuse | ZL-RFU20 ⁴ | ZL-D3-CBL18* |
| D3-08TR ¹ | 10 | See Note 1 | | |
| D3-16TR ² | 18 | Feedthrough | ZL-RTB20 | ZL-D3-CBL18* |
| | | Fuse | ZL-RFU20 ⁴ | ZL-D3-CBL18* |
| F3-08TRS-1 ² | 18 | Feedthrough | ZL-RTB20 | ZL-D3-CBL18* |
| F3-08TRS-2 ² | 18 | Feedthrough | ZL-RTB20 | ZL-D3-CBL18* |

* Select the cable length by replacing the * with: Blank = 0.5m, -1 = 1.0m, or -2 = 2.0m.

¹These I/O modules have non-removable terminal blocks which can be terminated using the ZL-CBL24-1P or 2P pigtail cable and the ZL-RTB20 module of the ZIPLink wiring system.

²Caution: The D3-16TR, F3-08TRS-1 and F3-08TRS-2 relay outputs are derated not to exceed 2A per point and 4A per common when used with the ZIPLink wiring system.

³The F3-08THM-J and F3-08THM-K modules are not supported by the ZIPLink wiring system.

⁴Note: Fuses (5 x 20 mm) are not included. See Edison Electronic Fuse section for (5 x 20 mm) fuse. S500 and GMA electronic circuit protection for fast-acting maximum protection. S506 and GMC electronic circuit protection for time-delay performance. Ideal for inductive circuits.

To ensure proper operation, do not exceed the voltage and current rating of ZIPLink module. ZL-RFU20 = 2A per circuit; ZL-RFU40 = 400 mA per circuit.

PLC I/O Modules to ZIPLink Connector Modules - DL405

| DL405 PLC Input Module ZIPLink Selector | | | | |
|---|------------|-------------|-----------------|---------------------------------|
| PLC | | ZIPLink | | |
| Input Module | # of Terms | Component | Module Part No. | Cable Part No. |
| D4-08ND3S | 20 | Feedthrough | ZL-RTB20 | ZL-D4-CBL20* |
| D4-16ND2 | 20 | Feedthrough | ZL-RTB20 | ZL-D4-CBL20* |
| | | Sensor | ZL-LTB16-24 | ZL-D4-CBL20* |
| D4-16ND2F | 20 | Feedthrough | ZL-RTB20 | ZL-D4-CBL20* |
| | | Sensor | ZL-LTB16-24 | ZL-D4-CBL20* |
| D4-32ND3-1 ² | 40 | Feedthrough | ZL-RTB40 | ZL-D24-CBL40* ZL-D24-CBL40*X |
| | | Sensor | ZL-LTB32-24 | |
| D4-32ND3-2 ² | 40 | Feedthrough | ZL-RTB40 | ZL-D24-CBL40* ZL-D24-CBL40*X |
| | | Sensor | ZL-LTB32-24 | |
| D4-64ND2 ¹ | 40 | Feedthrough | ZL-RTB40 | ZL-D24-CBL40* ZL-D24-CBL40*X |
| | | Sensor | ZL-LTB32-24 | |
| D4-08NA ³ | 11 | See Note 3 | | |
| D4-16NA | 20 | Feedthrough | ZL-RTB20 | ZL-D4-CBL20* |
| D4-16NA-1 | 20 | Feedthrough | ZL-RTB20 | ZL-D4-CBL20* |
| D4-16NE3 | 20 | Feedthrough | ZL-RTB20 | ZL-D4-CBL20* |
| | | Sensor | ZL-LTB16-24 | ZL-D4-CBL20* |
| F4-08NE3S | 20 | Feedthrough | ZL-RTB20 | ZL-D4-CBL20* |

| DL405 PLC Analog Module ZIPLink Selector | | | | |
|--|---------------|-------------|----------|--------------|
| PLC | | ZIPLink | | |
| Analog Module | # of Terms | Component | Module | Cable |
| F4-04AD | 20 | Feedthrough | ZL-RTB20 | ZL-D4-CBL20* |
| F4-04ADS | 20 | Feedthrough | ZL-RTB20 | ZL-D4-CBL20* |
| F4-08AD | 20 | Feedthrough | ZL-RTB20 | ZL-D4-CBL20* |
| F4-16AD-1 | 20 | Feedthrough | ZL-RTB20 | ZL-D4-CBL20* |
| F4-16AD-2 | 20 | Feedthrough | ZL-RTB20 | ZL-D4-CBL20* |
| F4-04DA-1 | 20 | Feedthrough | ZL-RTB20 | ZL-D4-CBL20* |
| F4-04DA-2 | 20 | Feedthrough | ZL-RTB20 | ZL-D4-CBL20* |
| F4-08DA-1 | 20 | Feedthrough | ZL-RTB20 | ZL-D4-CBL20* |
| F4-16DA-1 | 20 | Feedthrough | ZL-RTB20 | ZL-D4-CBL20* |
| F4-08DA-2 | 20 | Feedthrough | ZL-RTB20 | ZL-D4-CBL20* |
| F4-16DA-2 | 20 | Feedthrough | ZL-RTB20 | ZL-D4-CBL20* |
| F4-04DAS-1 | 20 | Feedthrough | ZL-RTB20 | ZL-D4-CBL20* |
| F4-04DAS-2 | 20 | Feedthrough | ZL-RTB20 | ZL-D4-CBL20* |
| F4-08THM ³ | T/C Wire Only | See Note 3 | | |
| F4-08THM-n ³ | T/C Wire Only | See Note 3 | | |
| F4-08RTD ³ | T/C Wire Only | See Note 3 | | |

| DL405 PLC Output Module ZIPLink Selector | | | | |
|--|------------|-------------|-----------------------|---------------------------------|
| PLC | | ZIPLink | | |
| Output Module | # of Terms | Component | Module Part No. | Cable Part No. |
| D4-08TD1 ³ | 11 | See Note 3 | | |
| F4-08TD1S ³ | 20 | See Note 3 | | |
| D4-16TD1 | 20 | Feedthrough | ZL-RTB20 | ZL-D4-CBL20* |
| | | Fuse | ZL-RFU20 ⁶ | ZL-D4-CBL20* |
| D4-16TD2 | 20 | Feedthrough | ZL-RTB20 | ZL-D4-CBL20* |
| | | Fuse | ZL-RFU20 ⁶ | ZL-D4-CBL20* |
| | | Relay | ZL-RR16-24-2 | ZL-D4-CBL20* |
| D4-32TD1 ² | 40 | Feedthrough | ZL-RTB40 | ZL-D24-CBL40* ZL-D24-CBL40*X |
| | | Fuse | ZL-RFU40 ⁶ | |
| D4-32TD1-1 | 40 | Feedthrough | ZL-RTB40 | ZL-D24-CBL40* ZL-D24-CBL40*X |
| | | Fuse | ZL-RFU40 ⁶ | |
| D4-32TD2 ² | 40 | Feedthrough | ZL-RTB40 | ZL-D24-CBL40* ZL-D24-CBL40*X |
| | | Fuse | ZL-RFU40 ⁶ | |
| D4-64TD1 ¹ | 40 | Feedthrough | ZL-RTB40 | ZL-D24-CBL40* ZL-D24-CBL40*X |
| | | Fuse | ZL-RFU40 ⁶ | |
| D4-08TA ³ | 11 | See Note 3 | | |
| D4-16TA | 20 | Feedthrough | ZL-RTB20 | ZL-D4-CBL20* |
| | | Fuse | ZL-RFU20 ⁶ | ZL-D4-CBL20* |
| D4-08TR ³ | 11 | See Note 3 | | |
| F4-08TRS-1 ⁵ | 20 | Feedthrough | ZL-RTB20 | ZL-D4-CBL20* |
| F4-08TRS-2 ⁵ | 20 | Feedthrough | ZL-RTB20 | ZL-D4-CBL20* |
| D4-16TR ⁴ | 20 | Feedthrough | ZL-RTB20 | ZL-D4-CBL20* |
| | | Fuse | ZL-RFU20 ⁶ | ZL-D4-CBL20* |

* Select the cable length by replacing the * with: Blank = 0.5m, -1 = 1.0m, or -2 = 2.0m.

¹The D4-64ND2 and D4-64TD1 modules have two 32-point connectors and require two ZIPLink cables and two ZIPLink connector modules.

²To make a custom cable for the 32 or 64-point modules, use: Ribbon-style Connector ZL-D24-CON-R, Solder-style 180° connector ZL-D24-CON or Solder-style 45° connector ZL-D24-CON-X

³These modules are not supported by the ZIPLink wiring system.

⁴Caution: The D4-16TR really outputs are derated not to exceed 2 Amps per point and 4 Amps per common when used with the ZIPLink wiring system.

⁵The F4-08TRS-1 and F4-08TRS-2 are derated not to exceed 2 Amps per point and 2 Amps per common when used with the ZIPLink wiring system.

⁶Note: Fuses (5 x 20 mm) are not included. See Edison Electronic Fuse section for (5 x 20 mm) fuse. S500 and GMA electronic circuit protection for fast-acting maximum protection. S506 and GMC electronic circuit protection for time-delay performance. Ideal for inductive circuits. To ensure proper operation, do not exceed the voltage and current rating of ZIPLink module. ZL-RFU20 = 2A per circuit; ZL-RFU40 = 400 mA per circuit.



NOTE: ZIPLINK CONNECTOR MODULES SPECIFICATIONS FOLLOW THE COMPATIBILITY MATRIX TABLES. ZIPLINK CABLES SPECIFICATIONS ARE AT THE END OF THIS ZIPLINK SECTION.



PAC I/O Modules to ZIPLink Connector Modules - Productivity3000

| Productivity3000 PAC Input Module ZIPLink Selector | | | | |
|--|------------|-------------|-----------------|----------------|
| PAC | | ZIPLink | | |
| Input Module | # of Terms | Component | Module Part No. | Cable Part No. |
| P3-08NAS | 20 | Feedthrough | ZL-RTB20 | ZL-P3-CBL20* |
| P3-08ND3S | 20 | Feedthrough | ZL-RTB20 | ZL-P3-CBL20* |
| P3-16NA | 20 | Feedthrough | ZL-RTB20 | ZL-P3-CBL20-*L |
| P3-16ND3 | 20 | Feedthrough | ZL-RTB20 | ZL-P3-CBL20-*L |
| | | Sensor | ZL-LTB16-24 | ZL-P3-CBL20-*L |
| P3-32ND3 | 40 | Feedthrough | ZL-RTB40 | ZL-CBL40* |
| | | Sensor | ZL-LTB32-24 | ZL-CBL40* |
| P3-64ND3 ¹ | 40 | Feedthrough | ZL-RTB40 | ZL-CBL40* |
| | | Sensor | ZL-LTB32-24 | ZL-CBL40* |

| Productivity3000 PAC Analog In Module ZIPLink Selector | | | | |
|--|---------------|-------------|----------|----------------|
| PAC | | ZIPLink | | |
| Analog Module | # of Terms | Component | Module | Cable |
| P3-04ADS | 20 | Feedthrough | ZL-RTB20 | ZL-P3-CBL20-*L |
| P3-08AD | 20 | Feedthrough | ZL-RTB20 | ZL-P3-CBL20-*L |
| P3-16AD-1 | 20 | Feedthrough | ZL-RTB20 | ZL-P3-CBL20-*L |
| P3-16AD-2 | 20 | Feedthrough | ZL-RTB20 | ZL-P3-CBL20-*L |
| P3-08RTD ² | Matched Only | See Note 2 | | |
| P3-08THM ² | T/C Wire Only | See Note 2 | | |
| P3-04DA | 20 | Feedthrough | ZL-RTB20 | ZL-P3-CBL20-*L |
| P3-08DA-1 | 20 | Feedthrough | ZL-RTB20 | ZL-P3-CBL20-*L |
| P3-08DA-2 | 20 | Feedthrough | ZL-RTB20 | ZL-P3-CBL20-*L |
| P3-06DAS-1 | 20 | Feedthrough | ZL-RTB20 | ZL-P3-CBL20-*L |
| P3-06DAS-2 | 20 | Feedthrough | ZL-RTB20 | ZL-P3-CBL20-*L |
| P3-16DA-1 | 20 | Feedthrough | ZL-RTB20 | ZL-P3-CBL20-*L |
| P3-16DA-2 | 20 | Feedthrough | ZL-RTB20 | ZL-P3-CBL20-*L |
| P3-8AD4DA-1 | 20 | Feedthrough | ZL-RTB20 | ZL-P3-CBL20-*L |
| P3-8AD4DA-2 | 20 | Feedthrough | ZL-RTB20 | ZL-P3-CBL20-*L |

| Productivity3000 PAC Specialty Module ZIPLink Selector | | | | |
|--|------------|-------------|-----------------|----------------|
| PAC | | ZIPLink | | |
| Input Module | # of Terms | Component | Module Part No. | Cable Part No. |
| P3-HSI | 40 | Feedthrough | ZL-RTB40 | ZL-CBL40*S |
| P3-HSO | 40 | Feedthrough | ZL-RTB40 | ZL-CBL40*S |



NOTE: ZIPLINK CONNECTOR MODULES SPECIFICATIONS FOLLOW THE COMPATIBILITY MATRIX TABLES. ZIPLINK CABLES SPECIFICATIONS ARE AT THE END OF THIS ZIPLINK SECTION.

| Productivity3000 PAC Output Module ZIPLink Selector | | | | |
|---|------------|------------------|-----------------------|----------------|
| PAC | | ZIPLink | | |
| Output Module | # of Terms | Component | Module Part No. | Cable Part No. |
| P3-08TAS | 20 | Feedthrough | ZL-RTB20 | ZL-P3-CBL20* |
| P3-08TD1S | 20 | Feedthrough | ZL-RTB20 | ZL-P3-CBL20-*L |
| P3-08TD2S | 20 | Feedthrough | ZL-RTB20 | ZL-P3-CBL20-*L |
| P3-08TRS | 20 | Feedthrough | ZL-RTB20 | ZL-P3-CBL20* |
| P3-16TA | 20 | Feedthrough | ZL-RTB20 | ZL-P3-CBL20* |
| | | Fuse | ZL-RFU20 | ZL-P3-CBL20* |
| P3-16TD1 | 20 | Feedthrough | ZL-RTB20 | ZL-P3-CBL20* |
| | | Fuse | ZL-RFU20 ⁴ | ZL-P3-CBL20* |
| | | Relay (sinking) | ZL-RR16-24-1 | ZL-P3-CBL20* |
| P3-16TD2 | 20 | Feedthrough | ZL-RTB20 | ZL-P3-CBL20* |
| | | Fuse | ZL-RFU20 ⁴ | ZL-P3-CBL20* |
| | | Relay (sourcing) | ZL-RR16-24-2 | ZL-P3-CBL20 |
| P3-16TR | 20 | Feedthrough | ZL-RTB20 | ZL-P3-CBL20* |
| | | Fuse | ZL-RFU20 ⁴ | ZL-P3-CBL20* |
| P3-08TRS-1 ³ | 20 | Feedthrough | ZL-RTB20 | ZL-P3-CBL20* |
| | | Fuse | ZL-RFU20 ⁴ | ZL-P3-CBL20* |
| P3-32TD1 | 40 | Feedthrough | ZL-RTB40 | ZL-CBL40* |
| | | Fuse | ZL-RFU40 ⁴ | ZL-CBL40* |
| P3-32TD2 | 40 | Feedthrough | ZL-RTB40 | ZL-CBL40* |
| | | Fuse | ZL-RFU40 ⁴ | ZL-CBL40* |
| P3-64TD1 ¹ | 40 | Feedthrough | ZL-RTB40 | ZL-CBL40* |
| | | Fuse | ZL-RFU40 ⁴ | ZL-CBL40* |
| P3-64TD2 ¹ | 40 | Feedthrough | ZL-RTB40 | ZL-CBL40* |
| | | Fuse | ZL-RFU40 ⁴ | ZL-CBL40* |
| P3-16TD3P | 40 | Feedthrough | ZL-RTB40 | ZL-CBL40* |

* Select the cable length by replacing the * with: Blank = 0.5m, -1 = 1.0m, or -2 = 2.0m.

¹ The P3-64ND3, P3-64TD1 and P3-64TD2 modules have two 32-point connectors and require two ZIPLink cables and two ZIPLink connector modules.

² These modules are not supported by the ZIPLink wiring system.

³ The P3-08TRS-1 output module is derated not to exceed 2A per point maximum when used with the ZIPLink wiring system.

⁴ Note: Fuses (5 x 20 mm) are not included. See Edison Electronic Fuse section for (5 x 20 mm) fuse. S500 and GMA electronic circuit protection for fast-acting maximum protection. S506 and GMC electronic circuit protection for time-delay performance. Ideal for inductive circuits.

To ensure proper operation, do not exceed the voltage and current rating of ZIPLink module. ZL-RFU20 = 2A per circuit; ZL-RFU40 = 400 mA per circuit.



| PLC I/O to 3rd Party Devices Z/Link Cable Selector | | | | |
|--|------------|-----------------|--------------------------|--------------------------------|
| PLC | | Z/Link | | |
| PLC Family | # of Terms | Number of Wires | Pigtail Cable Part No. † | Length (Replace * with number) |
| CLICK I/O Modules | 11 | 11 | ZL-C0-CBL11-*P | 1 = 1 meter, 2 = 2 meters |
| | 20 | 20 | ZL-C0-CBL20*P | |
| DL05 PLC Fixed I/O | 22 | 22 | ZL-D05-CBL22-*P | |
| DL06 PLC Fixed I/O | 24 | 24 | ZL-D06-CBL24-*P | |
| DL05 & DL06 I/O Modules | 8 | 8 | ZL-D0-CBL8-*P | |
| | 10 | 10 | ZL-D0-CBL10-*P | |
| | 13 | 13 | ZL-D0-CBL13-*P | |
| | 24 | 24 | ZL-D0-CBL24-*P | |
| DL205 I/O Modules | 10 | 10 | ZL-D2-CBL10-*P | |
| | 19 | 19 | ZL-D2-CBL19-*P | |
| | 40 | 40 | ZL-D24-CBL40-*P | |
| | | | ZL-D24-CBL40-*XP | |
| DL405 I/O Modules | 20 | 20 | ZL-D4-CBL20-*P | |
| | 40 | 40 | ZL-D24-CBL40-*XP | |
| | | | ZL-D24-CBL40-*P | |
| Productivity3000 I/O Modules | 20 | 20 | ZL-P3-CBL20-*P | |
| | 40 | 40 | ZL-P3-CBL40-*P | |

† X = 45° cable connector, all other cables have 180° cable connector



| Drive / Motor Controller (GS/DuraPulse/SureServo/SureStep/Stellar) ZIPLink Selector | | | | | | | | |
|---|----------------|-------------------|-------------------|-----------------|------------------------|--------------------|-------------------------|-------------------|
| Drive / Motor Controller | | Communications | | | ZIPLink Cable | | | |
| Controller | Comm Port Type | Network/Protocol | Connects to | Comm Port Type | Cable (2 meter length) | Cable Connectors | Other Hardware Required | |
| GS1 | RJ12 | RS-485 Modbus RTU | DL06 PLCs | Port 2 (HD15) | GS-485HD15-CBL-2 | RJ12 to HD15 | — | |
| | | | D2-260 CPU | | | | — | |
| | | | GS-EDRV100 | RJ12 | GS-EDRV-CBL-2 | RJ12 to RJ12 | — | |
| | | | ZL-CDM-RJ12Xxx* | RJ12 | GS-485RJ12-CBL-2 | | — | |
| | | | FA-ISOCON | 5-pin Connector | GS-ISOCON-CBL-2 | RJ12 to 5-pin plug | — | |
| GS2 | RJ12 | RS-232 Modbus RTU | CLICK PLCs | Port 2 (RJ12) | GS-RJ12-CBL-2 | RJ12 to RJ12 | — | |
| | | | DL05 PLCs | | | | — | |
| | | | DL06 PLCs | Port 2 (HD15) | | | FA-15HD | |
| | | | D2-250-1 CPU | | | | | |
| | | | D2-260 CPU | | | | | |
| | | | D4-450 CPU | Port 3 (25-pin) | | | | FA-CABKIT |
| | | P3-550 CPU | Port 2 (RJ12) | | | | | |
| | | RS-485 Modbus RTU | DL06 PLCs | Port 2 (HD15) | GS-485HD15-CBL-2 | RJ12 to HD15 | | — |
| | | | D2-260 CPU | | | | — | |
| | | | GS-EDRV100 | RJ12 | GS-EDRV-CBL-2 | RJ12 to RJ12 | — | |
| | | | ZL-CDM-RJ12Xxx* | RJ12 | GS-485RJ12-CBL-2 | | — | |
| | | | FA-ISOCON | 5-pin Connector | GS-ISOCON-CBL-2 | RJ12 to 5-pin plug | — | |
| DuraPulse (GS3) | RJ12 | | RS-485 Modbus RTU | DL06 PLCs | Port 2 (HD15) | GS-485HD15-CBL-2 | RJ12 to HD15 | — |
| | | D2-260 CPU | | — | | | | |
| | | GS-EDRV100 | | RJ12 | GS-EDRV-CBL-2 | RJ12 to RJ12 | — | |
| | | ZL-CDM-RJ12Xxx* | | RJ12 | GS-485RJ12-CBL-2 | | — | |
| | | FA-ISOCON | | 5-pin Connector | GS-ISOCON-CBL-2 | RJ12 to 5-pin plug | — | |
| Stellar (Soft Starter) SR44 Series | RJ45** | RS-485 Modbus RTU | DL06 PLCs | Port 2 (HD15) | SR44-485HD15-CBL-2 | RJ45 to HD15 | SR44-RS485 | |
| | | | D2-250-1 CPU | | | | | |
| | | | D2-260 CPU | RJ12 | SR44-485RJ45-CBL-2 | RJ45 to RJ12 | | |
| | | | ZL-CDM-RJ12Xxx* | | | | | |
| SureServo | IEEE1394 (CN3) | RS-232 Modbus RTU | CLICK PLCs | Port 2 (RJ12) | SVC-232RJ12-CBL-2 | 6-pin IEEE to RJ12 | — | |
| | | | DL05 PLCs | | | | — | |
| | | | DL06 PLCs | Port 2 (HD15) | | | FA-15HD | |
| | | | D2-250-1 CPU | | | | | |
| | | | D2-260 CPU | | | | | |
| | | | D4-450 CPU | Port 3 (25-pin) | | | | FA-CABKIT |
| | | P3-550 CPU | Port 2 (RJ12) | | | | | |
| | | RS-485 Modbus RTU | DL06 PLCs | Port 2 (HD15) | SVC-485HD15-CBL-2 | 6-pin IEEE to HD15 | | — |
| | | | D2-260 CPU | | | | — | |
| | | | ZL-CDM-RJ12Xxx* | RJ12 | SVC-485RJ12-CBL-2 | 6-pin IEEE to RJ12 | — | |
| | | | USB-485M | RJ45 | SVC-485CFG-CBL-2 | 6-pin IEEE to RJ45 | — | |
| | | | SureStep | RJ12 | RS-232 ASCII | DL06 PLCs | Port 2 (HD15) | STP-232HD15-CBL-2 |
| D2-250-1 CPU | — | | | | | | | |
| D2-260 CPU (Port2) | RJ12 | STP-232RJ12-CBL-2 | | | | RJ12 to RJ12 | | |
| DL05 PLCs | | | | | | | | |
| CLICK PLCs | | | | | | | | |

* When using the ZL-CDM-RJ12Xxx ZIPLink Communication Distribution Module, replace the lowercase xx with the number of RJ12 ports, i.e. 4 for four ports or 10 for ten ports. (ex: ZL-CDM-RJ12X4 or ZL-CDM-RJ12X10)

** The SR44-RS485 Communications Adapter must be installed for RS-485 communications with the Stellar soft starters.

| ZIPLink Serial Communication Cable Selector | | | | | |
|---|----------|----------------------|-----------------------------------|---------------------------------|---|
| PLC | | | ZIPLink | | |
| PLCs and Comm Modules | Port No. | Comm Port Type | Cable Connector Type | Cable Part No. (2 meter length) | D-Sub and RJ12 Feedthrough Module Part No. (optional) |
| CLICK | 1 | RJ12 | 6-pin RJ12 to RJ12 Crossover | ZL-RJ12-CBL-2 | ZL-RTB-RJ12 |
| | 2 | | 6-pin RJ12 to RJ12 Crossover | ZL-RJ12-CBL-2 | ZL-RTB-RJ12 |
| DL05 | 1 | RJ12 | 6-pin RJ12 to RJ12 Crossover | ZL-RJ12-CBL-2 | ZL-RTB-RJ12 |
| | 2 | | 6-pin RJ12 to RJ12 Crossover | ZL-RJ12-CBL-2 | ZL-RTB-RJ12 |
| DL06 | 1 | RJ12 | 6-pin RJ12 to RJ12 Crossover | ZL-RJ12-CBL-2 | ZL-RTB-RJ12 |
| D0-DCM | 1 | RJ12 | 6-pin RJ12 to RJ12 Crossover | ZL-RJ12-CBL-2 | ZL-RTB-RJ12 |
| D2-230 | 1 | RJ12 | 6-pin RJ12 to RJ12 Crossover | ZL-RJ12-CBL-2 | ZL-RTB-RJ12 |
| D2-240 | 1 | RJ12 | 6-pin RJ12 to RJ12 Crossover | ZL-RJ12-CBL-2 | ZL-RTB-RJ12 |
| | 2 | | 6-pin RJ12 to RJ12 Crossover | ZL-RJ12-CBL-2 | ZL-RTB-RJ12 |
| D2-250-1 | 1 | RJ12 | 6-pin RJ12 to RJ12 Crossover | ZL-RJ12-CBL-2 | ZL-RTB-RJ12 |
| D2-260 | 1 | RJ12 | 6-pin RJ12 to RJ12 Crossover | ZL-RJ12-CBL-2 | ZL-RTB-RJ12 |
| D2-DCM | 1 | 25-pin D-sub, Female | 25-pin Male D-sub to Female D-sub | ZL-DB25-CBL-2 | ZL-RTB-DB25 |
| D3-350 | 1 | RJ12 | 6-pin RJ12 to RJ12 Crossover | ZL-RJ12-CBL-2 | ZL-RTB-RJ12 |
| | 2 | 25-pin D-sub, Female | 25-pin Male D-sub to Female D-sub | ZL-DB25-CBL-2 | ZL-RTB-DB25 |
| D3-DCM | 1 | 25-pin D-sub, Female | 25-pin Male D-sub to Female D-sub | ZL-DB25-CBL-2 | ZL-RTB-DB25 |
| D4-430 | 1 | 15-pin D-sub, Female | 15-pin Male D-sub to Female D-sub | ZL-DB15-CBL-2 | ZL-RTB-DB15 |
| | 2 | 25-pin D-sub, Female | 15-pin Male D-sub to Female D-sub | ZL-DB25-CBL-2 | ZL-RTB-DB25 |
| D4-440 | 1 | 15-pin D-sub, Female | 15-pin Male D-sub to Female D-sub | ZL-DB15-CBL-2 | ZL-RTB-DB15 |
| | 2 | 25-pin D-sub, Female | 25-pin Male D-sub to Female D-sub | ZL-DB25-CBL-2 | ZL-RTB-DB25 |
| D4-450 | 0 | 15-pin D-sub, Female | 15-pin Male D-sub to Female D-sub | ZL-DB15-CBL-2 | ZL-RTB-DB15 |
| | 1 & 3 | 25-pin D-sub, Female | 25-pin Male D-sub to Female D-sub | ZL-DB25-CBL-2 | ZL-RTB-DB25 |
| | 2 | RJ12 | 6-pin RJ12 to RJ12 Crossover | ZL-RJ12-CBL-2 | ZL-RTB-RJ12 |
| D4-DCM | 1 | 25-pin D-sub, Female | 25-pin Male D-sub to Female D-sub | ZL-DB25-CBL-2 | ZL-RTB-DB25 |
| P3-550 | RS232 | RJ12 | 6-pin RJ12 to RJ12 Crossover | ZL-RJ12-CBL-2 | ZL-RTB-RJ12 |



| ZIP Link Specialty Modules Selector | | | |
|-------------------------------------|---|-----------------|---------------------------|
| ZIP Link | | | |
| Module | Type | Module Part No. | Cable Part No. (optional) |
| 24VDC Stand-Alone Relay | Single-Socket Relay | ZL-RLS1-24 | N/A |
| | Four Socket-Relay | ZL-RLS4-24 | |
| 120VAC Stand-Alone Relay | Single-Socket Relay | ZL-RLS1-120 | N/A |
| | Four-Socket Relay | ZL-RLS4-120 | |
| 24VDC Transorb | 8-Channel | ZL-TSD8-24 | N/A |
| 120VAC Transorb | 8-Channel | ZL-TSD8-24 | N/A |
| D-Sub Feedthrough | 9-pin Male & Female D-Subs to Terminal Blocks | ZL-RTB-DB09 | ZL-DB9-CBL-2 |
| | 15-pin Male & Female D-Subs to Terminal Blocks | ZL-RTB-DB15 | ZL-DB15-CBL-2 |
| | 25-pin Male & Female D-Subs to Terminal Blocks | ZL-RTB-DB25 | ZL-DB25-CBL-2 |
| RJ12 Feedthrough | 6-pin RJ12 to Terminal Block | ZL-RTB-RJ12 | ZL-RJ12-CBL-2 |
| Comm Port Adapters | 15-pin HD D-Sub to Terminal Block | ZL-CMA15 | N/A |
| | 15-pin HD D-Sub to Terminal Block with LED Indicators | ZL-CMA15L | N/A |
| Comm Distribution | 4-Port RJ12 to Terminal Block | ZL-CDM-RJ12X4 | N/A |
| | 10-Port RJ12 to Terminal Block | ZL-CDM-RJ12X10 | N/A |
| Feedthrough Module (SureServo I/O) | 50-pin to Terminal Blocks | ZL-RTB50 | ZL-SVC-50CBL* |

* Select the cable length by replacing the * with: Blank = 0.5m, -1 = 1.0m, or -2 = 2.0m



Connector Modules to 3rd Party Devices

Z/PLink Connector Modules to 3rd Party Devices Selector

Z/PLink

| Module | Type | Module Part No. | Pigtail Cable Part No. (optional) |
|-----------------------|-------------------------------|-----------------|-----------------------------------|
| Feedthrough Connector | 24-pin to Terminal Blocks | ZL-RTB20 | ZL-CBL24-1P ZL-CBL24-2P |
| | 40-pin to Terminal Blocks | ZL-RTB40 | ZL-CBL40-1P ZL-CBL40-2P |
| | 50-pin to Terminal Blocks | ZL-RTB50 | ZL-CBL50-1P ZL-CBL50-2P |
| Fuse | 16-Fuse, 24-pin | ZL-RFU20 | ZL-CBL24-1P ZL-CBL24-2P |
| | 32-Fuse, 40-pin | ZL-RFU40 | ZL-CBL40-1P ZL-CBL40-2P |
| 24VDC Powered Relay | 16-Relay, Sinking, 24-pin | ZL-RRL16-24-1 | ZL-CBL24-1P ZL-CBL24-2P |
| | 16-Relay, Sourcing, 24-pin | ZL-RRL16-24-2 | ZL-CBL24-1P ZL-CBL24-2P |
| Sensor Input | 16-Point with LEDs | ZL-LTB16-24 | ZL-CBL24-1P ZL-CBL24-2P |
| | 32-Point with LEDs | ZL-LTB32-24 | ZL-CBL40-1P ZL-CBL40-2P |
| D-Sub Feedthrough | 9-pin D-Sub to Terminal Block | ZL-RTB-DB09 | ZL-DB9F-CBL-2P |
| | | | ZL-DB9F-CBL-5P |

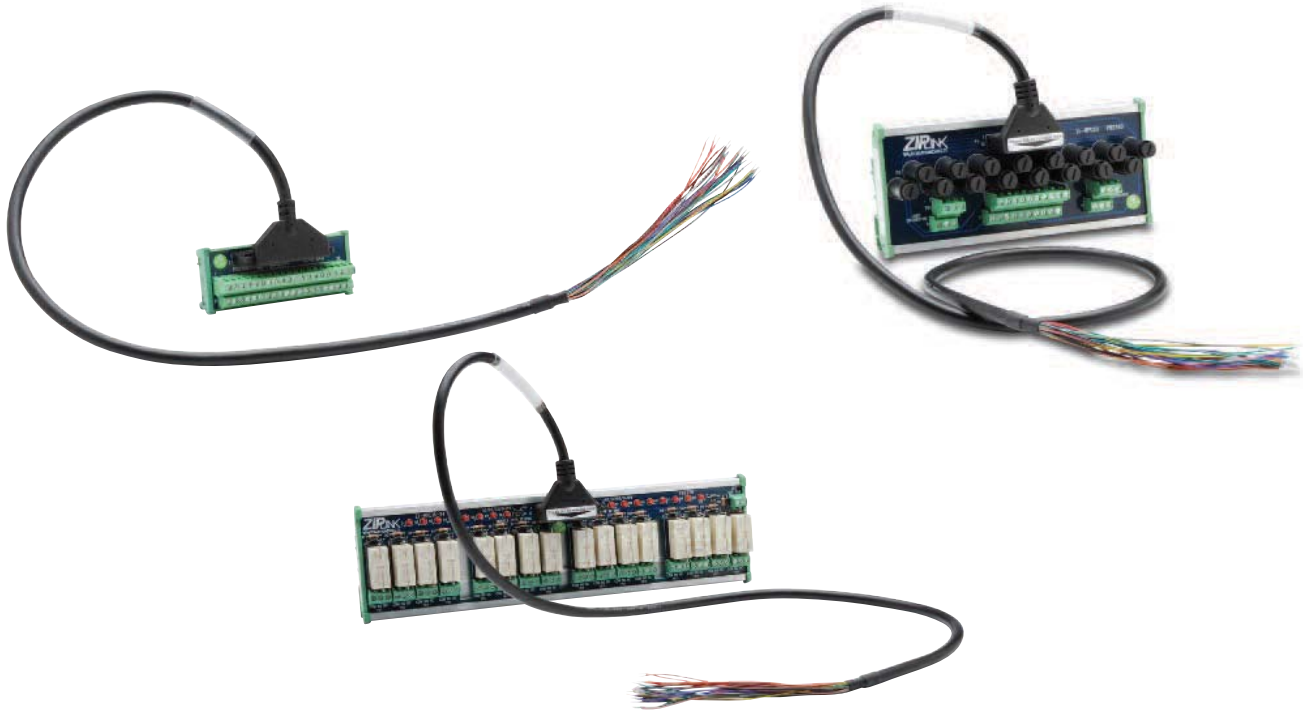



Feedthrough Connector Modules

Feedthrough modules provide low-cost and compact field wiring screw termination solutions for quickly connecting ZIPLink cables with PLCs. Modules mount on 35 mm DIN rail part #DN-R35S1.



ZL-RTB20



ZL-RTB40



ZL-RTB50

| Specifications | | | | | | | | | | | | |
|--|---|---------|-----------|--------------|---|---------|--------|--------------|---|---------|-----------|--------------|
| Feedthrough Modules | Part # | Pcs/Pkg | Price/Pkg | Weight (lbs) | Part # | Pcs/Pkg | Part # | Weight (lbs) | Part # | Pcs/Pkg | Price/Pkg | Weight (lbs) |
| | ZL-RTB20 | 1 | <--> | 0.26 | ZL-RTB40 | 1 | <--> | 0.22 | ZL-RTB50 | 1 | <--> | 0.33 |
| Description**** | 20-Pole Feedthrough Connector Module | | | | 40-Pole Feedthrough Connector Module | | | | 50-Pole Connector Module for interfacing SureServo I/O to a controller | | | |
| Maximum Voltage | 300VAC/VDC | | | | 36VAC/VDC | | | | 0-30VDC** | | | |
| UL Voltage Rating | 0-250VAC/VDC | | | | 0-30VAC/VDC** | | | | 24VDC | | | |
| Maximum Current per Circuit | 2A | | | | 500mA | | | | 0.2A | | | |
| Maximum Current per Common Circuit | 4A* | | | | N/A | | | | N/A | | | |
| Maximum Current per Module | 40A (all conductors combined including commons) | | | | 32A (all conductors combined including commons) | | | | 10A | | | |
| Number of Terminal Block Positions | 20 | | | | 40 | | | | 50 | | | |
| Surrounding Temperature Range | 32 to 140°F (0 to 60°C) | | | | | | | | | | | |
| Approvals | File # E200031 UL, cUL, Class 1, Division 2, Groups A,B,C,D Hazardous Locations, CE, EN 61131-2:2007 | | | | | | | | | | | |
| Terminal Block Contacts | Copper alloy, tin-lead plated | | | | | | | | | | | |
| Wire Range (Rated Cross Section)*** | 12-24AWG Solid or Stranded Copper Conductor (2.5mm ²) | | | | | | | | | | | |
| Wire Strip Length | 0.24-0.27" (6-7mm) | | | | | | | | | | | |
| Screw Torque | 4.4 in-lbs (0.5 Nm) | | | | | | | | | | | |
| Connector Type | Molex Micro-Fit 3.0, 24 pin connector Example: Receptacle 43020-2400 Pins 43031 Series, Male | | | | 3M 34000 Series IDC Connector, strain relief is required to latch to header. Example: Socket 3417-7640, Strain relief 3448-3040 | | | | 3M mini DELTA Ribbon (MDR), 101 Series, 50 pin Example: Plug 10150 - 3000VE, Shell 10350 - 52A0 - 008 | | | |
| Connecting Cables (Sold Separately) | See Wiring Selection Guides at the beginning of this section. See Connection Cable specifications tables at the end of this section. | | | | See Wiring Selection Guides at the beginning of this section. See Connection Cable specifications tables at the end of this section. | | | | ZL-SVC-CBL50 (0.5m/1.6ft) ZL-SVC-CBL50-1 (1m/3.3ft) ZL-SVC-CBL50-2 (2m/6.6ft) See Connection Cable specifications tables at the end of this section. | | | |
| Dimensions (WxHxD) | 2.64" x 3.42" x 2.03" (67.0mm x 86.8mm x 51.6mm) | | | | 4.48" x 1.89" x 1.84" (113.7mm x 48.1mm x 46.8mm) | | | | 5.46" x 1.89" x 1.84" (138.6mm x 48.1mm x 46.8mm) | | | |
| Cable/Wire Clearance | 0.5" (12.7mm) Required | | | | | | | | | | | |
| Mounting Restrictions | None | | | | | | | | | | | |

*The 4 common circuits are at terminal block positions 1, 6, 11, and 16. Each common circuit has 2 cable wires per terminal.

**Use Class 2 power supply

***Use conductors rated 60°/75°C

****Connecting cables are for internal wiring only.

Note: See wiring details and dimensional drawings on our Web site at:
<http://www.automationdirect.com/static/manuals/ziplinks/ziplinks.html>

Fuse modules provide fuse protection for PLC output devices. The 16 and 32-point fuse modules include replaceable fuses and protective safety covers. Use with CLICK, DL05/06/205/305/405 PLCs. Modules mount on 35 mm DIN rail part #DN- R35S1.



ZL-RFU20



ZL-RFU40

| Specifications | | | | | | | | |
|--|---|---------|-----------|--------------|---|---------|-----------|--------------|
| Fuse Modules | Part # | Pcs/Pkg | Price/Pkg | Weight (lbs) | Part # | Pcs/Pkg | Price/Pkg | Weight (lbs) |
| | ZL-RFU20 | 1 | <--> | 0.79 | ZL-RFU40 | 1 | <--> | 1.10 |
| Description**** | 16-point fuse connector module | | | | 32-point fuse connector module | | | |
| Operation Voltage | 0-250VAC/0-75VDC* | | | | 0-30VDC | | | |
| UL Rated Current | 1A per point | | | | 0.3A per circuit** | | | |
| Maximum Current per Circuit | 2A | | | | 0.4A | | | |
| Maximum Current per Module | 32A | | | | 20A | | | |
| Number of Circuits | 16 | | | | 32 | | | |
| Field to Logic Side Isolation | 1800VAC applied for 1 second | | | | | | | |
| Insulation Resistance | >10M Ω @ 500VDC | | | | | | | |
| Surrounding Temperature Range | 32 to 140°F (0 to 60°C) | | | | | | | |
| Approvals | File # E200031 UL, cUL, Class 1, Division 2, Groups A,B,C,D Hazardous Locations, CE, EN 61131-2:2007 | | | | | | | |
| Terminal Block Contacts | Copper alloy, tin-lead plated | | | | | | | |
| Wire Range (Rated Cross Section)*** | 12-24AWG Solid or Stranded Copper Conductor (2.5mm ²) | | | | | | | |
| Wire Strip Length | 0.24-0.27" (6-7mm) | | | | | | | |
| Screw Torque | 4.4 in-lbs (0.5 Nm) | | | | | | | |
| Fuses (Not Installed) | Sixteen 5x20mm, 250V, 2 Amp fast blow | | | | Thirty-two 5x20mm, 250V, 0.4 Amp fast blow | | | |
| Replacement Fuse | See Edison 5x20mm Glass Fuse Section range up to a Max. 2 Amp fuse | | | | See Edison 5x20mm Glass Fuse Section range up to a Max. 0.4 Amp fuse | | | |
| Dimensions (WxHxD) | 7.21" x 3.42" x 2.25" (183mm x 86.8mm x 57.2mm) | | | | 10.26" x 3.40" x 2.25" (260.5mm x 86.4mm x 57.2mm) | | | |
| Connector Type | Molex Micro-Fit 3.0, 24 pin connector Example receptacle 43020-2400, Pins 43031 Series, Male | | | | 3M 34000 Series IDC Connector, strain relief is required to latch to header. Example: Socket 3417-7640, Strain relief 3448-3040 | | | |
| Connecting Cables (Sold Separately) | See Wiring Selection Guides at the beginning of this section. See Connection Cable specifications tables at the end of this section. | | | | See Wiring Selection Guides at the beginning of this section. See Connection Cable specifications tables at the end of this section. | | | |
| Cable/Wire Clearance | 0.5" (12.7mm) Required | | | | | | | |
| Mounting Restrictions | None | | | | | | | |

* UL rated 0-75VDC applies when using a DC rated fuse (not supplied), example: Littelfuse 217 series.

** Use Class 2 power supply - This refers to the ZL-RFU40 only.

*** Use conductors rated 60°/75°C

****Connecting cables are for internal wiring only.

Note: See wiring details and dimensional drawings on our Web site at:
<http://www.automationdirect.com/static/manuals/ziplinks/ziplinks.html>

24V DC-Powered Relay Modules

DC-powered relay modules provide isolation, switch high current (10A) loads, and include diode protection to prevent voltage spikes at the relay coil from damaging connected 16-point PLC I/O modules. Relays are included with these modules.

Modules mount on 35 mm DIN rail part #DN-R15S1 (15 mm DIN rail optional).



ZL-RRL16-24-1



ZL-RRL16-24-2

| Specifications | | | | | | | | |
|--|---|---------|-----------|--------------|--|---------|-----------|--------------|
| 24V DC-Powered Relay Module | Part # | Pcs/Pkg | Price/Pkg | Weight (lbs) | Part # | Pcs/Pkg | Price/Pkg | Weight (lbs) |
| | ZL-RRL16-24-1 | 1 | <--> | 1.45 | ZL-RRL16-24-2 | 1 | <--> | 1.45 |
| Description | 16 Output Relay module, sinking, with LEDs, 24 VDC coil | | | | 16 Output Relay module, sourcing, with LEDs, 24 VDC coil | | | |
| Operating Frequency | 20 cycles per minute electrical, 300 cycles per minute mechanical | | | | | | | |
| Isolation Coil to Contact | 2500VAC for 1 minute | | | | | | | |
| Isolation NC Contact to NO Contact Same Relay | 1000VAC for 1 minute | | | | | | | |
| Isolation Between Relays | 1000VAC for 1 minute | | | | | | | |
| Red LED Indicator State Relay | ON = relay energized, OFF = relay de-energized | | | | ON = relay de-energized, OFF = relay energized | | | |
| Operating Temperature Range | 32 to 140°F (0 to 60°C) | | | | | | | |
| Humidity Range | 45 to 85% RH | | | | | | | |
| Terminal Block Contacts | Copper alloy, tin-lead plated | | | | | | | |
| Wire Range* | 12-24AWG Solid or Stranded Conductor | | | | | | | |
| Wire Strip Length | 0.24-0.27" (6-7mm) | | | | | | | |
| Screw Torque | 4.4 in-lbs (0.5 Nm) | | | | | | | |
| Connector Type | Molex Micro-Fit 3.0, 24 pin connector, example receptacle 43020-2400, Pins 43031 Series, Male | | | | | | | |
| Connecting Cables (Sold Separately) | See Wiring Selection Guides at the beginning of this section. See Connection Cable specifications tables at the end of this section. | | | | | | | |
| Replacement Relays | ZL-RELAY-24X4, Qty. 4/pkg | | | | | | | |
| Dimensions (WxHxD) | 11.77" x 3.42" x 2.14" (299mm x 86.8mm x 54.3mm) | | | | | | | |
| Approvals | File # E157382 UL, cUL 508 | | | | | | | |
| Cable/Wire Clearance | 0.5" (12.7mm) required | | | | | | | |
| Mounting Restrictions | Horizontal mounting only, non-corrosive environment | | | | | | | |

| Relay Specifications** | | | |
|-------------------------------------|--|--|------------------------|
| Contact | | Coil | |
| Current Rating | 30VDC @ 10A, 250VAC @ 8A, General Use | Input Voltage Rating | 24VDC (-20%/+30%) |
| Contact Type | 1 Form C (SPDT) | Maximum Continuous Coil Voltage | 31.2VDC |
| Contact Voltage (per point)* | 250VAC/30VDC | Rated Current per Coil | 16.7mA (±10%) @ 24 VDC |
| Maximum Power Inductive | 2000VA General Use | Coil Resistance | 1440Ω (±10%) |
| Maximum Power Resistive | AC 2000VA, DC 300W | Power Consumption per Coil | 0.4W |
| Maximum Switching Voltage | 250VAC, 110VDC | Total Coil Supply Current Max. | 293mA (all relays on) |
| Minimum Load | 10mA @ 5VDC | Pick Up Current Max. per Coil | 15mA |
| Contact Resistance | 100mΩ Max @ 1A, 6VDC | Drop-Out Voltage Min. | 1.2VDC |
| Contact Material | AgNi (Silver Nickel Alloy) | Pick-Up Voltage Max. | 19.2VDC |
| Vibration Resistance | 10 to 55 Hz dual amplitude width 1.5mm | Off to On/On to Off Response Time | 12ms/8ms |
| Shock Resistances | 1000m/s ² endurance, 100m/s ² operation | | |
| Service Life | Mechanical: 10,000,000 Operations at no load condition; Electrical: 100,000 Operations at rated resistive load | | |

* Use conductors rated for 60°/75°C for relay outputs.

** Relay modules are reverse polarity protected and will not operate if reverse voltage is connected.

Note: See wiring details and dimensional drawings on our Web site at:

<http://www.automationdirect.com/static/manuals/ziplinks/ziplinks.html>

Our single and four-socket 24 VDC stand-alone relay modules use plug-in relays for switching high current (10A) loads. Relays are included with the modules.

Modules mount on 35 mm DIN rail part #DN-R35S1.



ZL-RLS1-24



ZL-RLS4-24

| Specifications | | | | | | | | |
|--|---|---------|-----------|--------------|--|---------|-----------|--------------|
| 24VDC Stand-Alone Relay Modules | Part # | Pcs/Pkg | Price/Pkg | Weight (lbs) | Part # | Pcs/Pkg | Price/Pkg | Weight (lbs) |
| | ZL-RLS1-24 | 1 | <---> | 0.10 | ZL-RLS4-24 | 1 | <---> | 0.45 |
| Description | Single-socketed relay with 24VDC relay with LED | | | | Four-socketed relays with 24VDC relays with LEDs | | | |
| Mechanical Life | 10,000,000 Operations at no load condition | | | | | | | |
| Electrical Life | 100,000 Operations at rated resistive load | | | | | | | |
| Operating Frequency | 20 cycles per minute electrical, 300 cycles per minute mechanical | | | | | | | |
| Isolation Coil to Contact | 2500VAC for 1 minute | | | | | | | |
| Isolation NC Contact to NO Contact Same Relay | 1000VAC for 1 minute | | | | | | | |
| Isolation Between Relays | N/A | | | | 1000VAC for 1 minute | | | |
| Red LED Indicator State Relay | ON = relay energized, OFF = relay de-energized | | | | | | | |
| Operating Temperature Range | 32 to 140°F (0 to 60°C) | | | | | | | |
| Humidity Range | 45 to 85% RH | | | | | | | |
| Vibration Resistance | 10 to 55 Hz dual amplitude width 1.5mm | | | | | | | |
| Shock Resistances | 1000m/s ² endurance, 100m/s ² operation | | | | | | | |
| Terminal Block Contacts | Copper alloy, tin-lead plated | | | | | | | |
| Wire Range* | 12-24AWG Solid or Stranded Conductor | | | | | | | |
| Wire Strip Length | 0.24-0.27" (6-7mm) | | | | | | | |
| Screw Torque | 4.4 in-lbs (0.5 Nm) | | | | | | | |
| Dimensions (WxHxD) | 0.88" x 3.04" x 2.14" (22.4mm x 77.2mm x 54.3mm) | | | | 3.71" x 3.42" x 2.14" (94.3mm x 86.8mm x 54.3mm) | | | |
| Replacement Relays | ZL-RELAY-24X4, Qty. 4/pkg | | | | | | | |
| Approvals | File # E157382 UL, cUL 508 | | | | | | | |
| Cable/Wire Clearance | 0.5" (12.7mm) Required | | | | | | | |

Note: These modules do not provide transient protection on the relay coil.

| Relay Specifications | | | |
|-------------------------------------|---|--|------------------------|
| Contact | | Coil | |
| Current Rating | 30VDC @ 10A 250VAC @ 8A General Use | Input Voltage Rating | 24VDC (-20%/+30%) |
| Contact Type | 1 Form C (SPDT) | Maximum Continuous Coil Voltage | 31.2VDC |
| Contact Voltage (per point)* | 250VAC/30VDC | Rated Current per Coil | 16.7mA (±10%) @ 24 VDC |
| Maximum Power Inductive | 2000VA General Use | Coil Resistance | 1440Ω (±10%) |
| Maximum Power Resistive | AC 2000VA, DC 300W | Power Consumption per Coil | 0.4W |
| Maximum Switching Voltage | 250VAC, 110VDC | Pick Up Current Max. per Coil | 15mA |
| Minimum Load | 10mA @ 5VDC | Drop-Out Voltage Min. | 1.2VDC |
| Contact Resistance | 100mΩ Max @ 1A, 6VDC | Pick-Up Voltage Max. | 19.2VDC |
| Contact Material | AgNi (Silver Nickel Alloy) | Off to On/On to Off Response Time | 12ms/8ms |

Note: See wiring details and dimensional drawings on our Web site at: <http://www.automationdirect.com/static/manuals/ziplinks/ziplinks.html>

* Use conductors rated for 60°/75°C for relay outputs.

120VAC Stand-Alone Relay Modules

Our AC-powered stand-alone relay modules provide isolation, switch high current (10A) loads and are offered in single or 4-socket modules. Relays are included with the modules.

Modules mount on 35 mm DIN rail part #DN-R35S1.



ZL-RLS1-120



ZL-RLS4-120

| Specifications | | | | | | | | |
|--|---|---------|-----------|--------------|---|---------|-----------|--------------|
| 120VAC Stand-Alone Relay Modules | Part # | Pcs/Pkg | Price/Pkg | Weight (lbs) | Part # | Pcs/Pkg | Price/Pkg | Weight (lbs) |
| | ZL-RLS1-120 | 1 | <---> | 0.10 | ZL-RLS4-120 | 1 | <---> | 0.45 |
| Description | Single-socketed relay with 120VAC relay with LED | | | | Four-socketed relays with 120VAC relays with LEDs | | | |
| Mechanical Life | 10,000,000 Operations at no load condition | | | | | | | |
| Electrical Life | 100,000 Operations at rated resistive load | | | | | | | |
| Operating Frequency | 20 cycles per minute electrical, 300 cycles per minute mechanical | | | | | | | |
| Isolation Coil to Contact | 2500VAC for 1 minute | | | | | | | |
| Isolation NC Contact to NO Contact Same Relay | 1000VAC for 1 minute | | | | | | | |
| Isolation Between Relays | N/A | | | | 1000VAC for 1 minute | | | |
| Red LED Indicator State Relay | ON = relay energized, OFF = relay de-energized | | | | | | | |
| Operating Temperature Range | 32 to 140°F (0 to 60°C) | | | | | | | |
| Humidity Range | 45 to 85% RH | | | | | | | |
| Vibration Resistance | 10 to 55 Hz dual amplitude width 1.5mm | | | | | | | |
| Shock Resistances | 1000m/s ² endurance, 100m/s ² operation | | | | | | | |
| Terminal Block Contacts | Copper alloy, tin-lead plated | | | | | | | |
| Wire Range* | 12-24AWG Solid or Stranded Conductor | | | | | | | |
| Wire Strip Length | 0.24-0.27" (6-7mm) | | | | | | | |
| Screw Torque | 4.4 in-lbs (0.5 Nm) | | | | | | | |
| Dimensions (WxHxD) | 0.88" x 3.04" x 2.14" (22.4mm x 77.2mm x 54.3mm) | | | | 3.71" x 3.42" x 2.14" (94.3mm x 86.8mm x 54.3mm) | | | |
| Replacement Relays | ZL-RELAY-120X4, Qty. 4/pkg | | | | | | | |
| Approvals | File # E157382 UL, cUL 508 | | | | | | | |
| Cable/Wire Clearance | 0.5" (12.7mm) Required | | | | | | | |

| Relay Specifications | | | |
|-------------------------------------|---|--|--|
| Contact | | Coil | |
| Current Rating | 30VDC @ 10A 250VAC @ 8A General Use | Input Voltage Rating | 115VAC (-20%/+30%), 50-60Hz |
| Contact Type | 1 Form C (SPDT) | Maximum Continuous Coil Voltage | 150VAC |
| Contact Voltage (per point)* | 250VAC/30VDC | Rated Current per Coil | 7.65mA (±10%) @ 115VAC 50Hz 6.30mA (±10%) @ 115VAC 60Hz |
| Maximum Power Inductive | 2000VA General Use | Coil Resistance | 8100Ω (±10%) |
| Maximum Power Resistive | AC 2000VA, DC 300W | Power Consumption per Coil | 0.88W @ 50Hz 0.73W @ 60Hz |
| Maximum Switching Voltage | 250VAC, 110VDC | Drop-Out Voltage Min. | 34.5VAC |
| Minimum Load | 10mA @ 5VDC | Pick-Up Voltage Max. | 92VAC |
| Contact Resistance | 100mΩ Max @ 1A, 6VDC | Off to On/On to Off Response Time | 12ms/8ms |
| Contact Material | AgNi (Silver Nickel Alloy) | | |

Note: See wiring details and dimensional drawings on our Web site at: <http://www.automationdirect.com/static/manuals/ziplinks/ziplinks.html> * Use conductors rated for 60°/75°C for relay outputs.

LED modules provide simple and logical termination for 3-wire sensors or other devices. These modules offer visual LED indication of device input status for quick troubleshooting. The LED/sensor modules are available in 16 and 32-point versions.

Modules mount on 35 mm DIN rail part #DN-R35S1.



ZL-LTB16-24

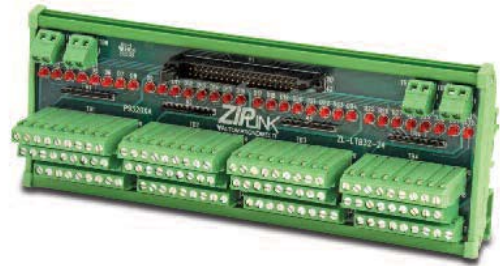

ZL-LTB32-24

| Specifications | | | | | | | | |
|--|--|-------------|-----------|--------------|--|-------------|-----------|--------------|
| Sensor Input Modules | Part # | Pcs/Pkg | Price/Pkg | Weight (lbs) | Part# | Pcs/Pkg | Price/Pkg | Weight (lbs) |
| | | ZL-LTB16-24 | 1 | <---> | 0.43 | ZL-LTB32-24 | 1 | <---> |
| Description*** | 16-point, 24 Volt Sensor Input Module with LEDs | | | | 32-point, 24 Volt Sensor Input Module with LEDs | | | |
| Maximum Voltage | 50VAC/VDC (-10%/+20%) | | | | | | | |
| UL Voltage Rating* | 0-30VAC/VDC (-10%/+20%) | | | | | | | |
| Nominal Current per Input | I/O module max. input current per point plus 2mA for LED indicator | | | | | | | |
| Maximum Current per Input | 500mA | | | | | | | |
| Maximum Current per Power Group (P1, P2, P3, or P4) | 4A | | | | | | | |
| Surrounding Temperature Range | 32 to 140°F (0 to 60°C) | | | | | | | |
| Approvals | File # E200031 UL, cUL, Class 1, Division 2, Groups A,B,C,D Hazardous Locations, CE, EN 61131-2:2007 | | | | | | | |
| LED Indicator Circuit | 2mA @ 24VDC per LED | | | | | | | |
| Terminal Block Contacts | Copper alloy, tin-lead plated | | | | | | | |
| Wire Range (Rated Cross Section)** | 12-24AWG Solid or Stranded Copper Conductor (2.5mm ²) | | | | | | | |
| Wire Strip Length | 0.24-0.27" (6-7mm) | | | | | | | |
| Screw Torque | 4.4 in-lbs (0.5 Nm) | | | | | | | |
| Connector Type | Molex Micro-Fit 3.0, 24 pin connector Example: Receptacle 43020-2400 Pins 43031 Series, Male | | | | 3M 34000 Series IDC Connector, strain relief is required to latch to header. Example: Socket 3417-7640, Strain relief 3448-3040 | | | |
| Connecting Cables (Sold Separately) | See Wiring Selection Guides at the beginning of this section. See Connection Cable specifications tables at the end of this section. | | | | See Wiring Selection Guides at the beginning of this section. See Connection Cable specifications tables at the end of this section. | | | |
| Dimensions (WxHxD) | 4.41" x 3.42" x 2.47" (112mm x 86.8mm x 62.8mm) | | | | 8.50" x 3.42" x 2.47" (216mm x 86.8mm x 62.8mm) | | | |
| Cable/Wire Clearance | 0.5" (12.7mm) Required. | | | | | | | |
| Mounting Restrictions | None | | | | | | | |

* Use Class 2 power supply.

** Use conductors rated for 60°/75°C for relay outputs.

***Connecting cables are for internal wiring only.

Note: See wiring details and dimensional drawings on our Web site at:
<http://www.automationdirect.com/static/manuals/ziplinks/ziplinks.html>

24VDC and 120VAC Transorb Modules

Our transorb diode modules are 8-channel devices used to suppress counter-electromotive force (CEMF) generated by switching inductive loads such as air solenoids, contactors, motor starters, interposing relays, etc., which can cause unexpected PLC system shutdown.

Modules mount on 35 mm DIN rail part #DN-R35S1.



ZL-TSD8-24



ZL-TSD8-120

| Specifications | | | | | | | | |
|--|--|---------|-----------|--------------|--|---------|-----------|--------------|
| 24VDC and 120VAC Transorb Modules | Part # | Pcs/Pkg | Price/Pkg | Weight (lbs) | Part # | Pcs/Pkg | Price/Pkg | Weight (lbs) |
| | ZL-TSD8-24 | 1 | <---> | 0.19 | ZL-TSD8-120 | 1 | <---> | 0.22 |
| Description** | 8-Channel Transient Voltage Suppressor Module, 24VDC | | | | 8-Channel Transient Voltage Suppressor Module, 120VAC | | | |
| Approvals | File # E200031 UL, cUL, Class 1, Division 2, Groups A,B,C,D Hazardous Locations, CE, EN 61131-2:2007 | | | | | | | |
| Number of Circuits | 8 | | | | | | | |
| UL Voltage Rating | 24VDC Voltage Breakdown: Min: 28.5VDC Normal: 30VDC Max: 31.5VDC | | | | 120VAC Voltage Breakdown: Min: 171 Normal: 180 Max: 189 | | | |
| Peak Power Dissipation | 1500W surge capability at 1ms | | | | | | | |
| Maximum Surge Current | 2A | | | | | | | |
| Terminal Block Contacts | Copper alloy, tin-lead plated | | | | | | | |
| 1-Wire Range (Rated Cross Section)* | 12-24AWG Solid or Stranded Copper Conductor (2.5mm ²) | | | | | | | |
| 2-Wire Range (Rated Cross Section)* | 16-24AWG Solid or Stranded Copper Conductor (2.5mm ²) | | | | | | | |
| Wire Strip Length | 0.24-0.27" (6-7mm) | | | | | | | |
| Screw Torque | 4.4 in-lbs (0.5Nm) | | | | | | | |
| Surrounding Temperature Range | 32 to 140°F (0 to 60°C) | | | | | | | |
| Dimensions (WxHxD) | 2.26" x 3.42" x 1.57" (57.4mm x 86.8mm x 40mm) | | | | | | | |
| Cable/Wire Clearance | 0.5" (12.7mm) Required | | | | | | | |
| Mounting Restrictions | None | | | | | | | |

* Use conductors rated for 60°/75°C.

**Connecting cables are for interlan wiring only.

The waveform in the figure below shows the energy released when opening a contact switching a 24 VDC solenoid.

Notice the large voltage spike.

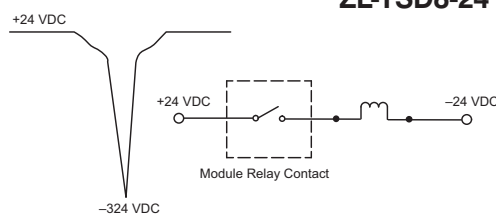

This figure shows the same circuit with a transorb (TVS) across the coil. Notice that the voltage spike is significantly reduced.

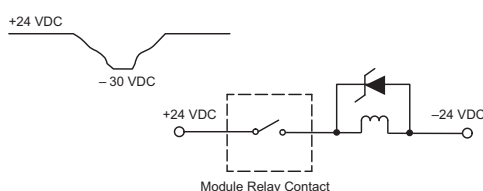

The waveform in the figure below shows the energy released when opening a contact switching a 120 VAC solenoid.

Notice the large voltage spike.

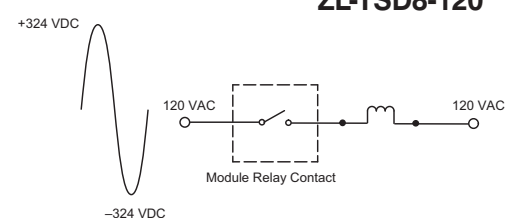

This figure shows the same circuit with a transorb (TVS) across the coil. Notice that the voltage spike is significantly reduced.

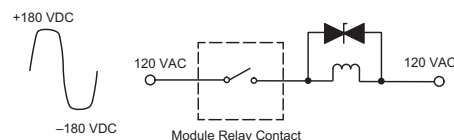

Note: See wiring details and dimensional drawings on our Web site at <http://www.automationdirect.com/static/manuals/ziplinks/ziplinks.html>

D-Sub Feedthrough Modules

Available in male and female, 9, 15 or 25-pin versions, these connector modules provide a fast, convenient method of transitioning between

D-Sub connectors and field wiring through the use of screw terminals.

Modules mount on 35 mm DIN rail part #DN-R35S1.



ZL-RTB-DB09



ZL-RTB-DB15



ZL-RTB-DB25

Specifications

| D-Sub Feedthrough Modules | Part # | Pcs/Pkg | Price/Pkg | Weight (lbs) | Part # | Pcs/Pkg | Price/Pkg | Weight (lbs) | Part # | Pcs/Pkg | Price/Pkg | Weight (lbs) |
|--|--|-------------|-----------|--------------|---|-------------|-----------|--------------|---|-------------|-----------|--------------|
| | | ZL-RTB-DB09 | 1 | <---> | 0.08 | ZL-RTB-DB15 | 1 | <---> | 0.13 | ZL-RTB-DB25 | 1 | <---> |
| Description** | 9-pin male and female D-sub to terminal blocks | | | | 15-pin male and female D-sub to terminal blocks | | | | 25-pin male and female D-sub to terminal blocks | | | |
| Approvals | File # E200031 UL, cUL, Class 1, Division 2, Groups A,B,C,D Hazardous Locations, CE, EN 61131-2:2007 | | | | | | | | | | | |
| UL Voltage Rating*** | 30VDC | | | | | | | | | | | |
| Maximum Current per Circuit | 1A | | | | | | | | | | | |
| Number of Circuits | 9 | | | | 15 | | | | 25 | | | |
| Wire Range (Rated Cross Section)* | 12-24AWG Solid or Stranded Copper Conductor (2.5mm ²) | | | | | | | | | | | |
| Wire Strip Length | 0.24-0.27" (6-7mm) | | | | | | | | | | | |
| Screw Torque | 4.4 in-lbs (0.5 Nm) | | | | | | | | | | | |
| Surrounding Temperature Range | 32 to 140°F (0 to 60°C) | | | | | | | | | | | |
| Terminal Block Contacts | Copper alloy, tin-lead plated | | | | | | | | | | | |
| Dimensions (WxHxD) | 1.74" x 3.42" x 2.03" (44.1mm x 86.8mm x 51.6mm) | | | | 2.18" x 3.42" x 2.03" (55.4mm x 86.8mm x 51.6mm) | | | | 3.50" x 3.42" x 2.03" (88.9mm x 86.8mm x 51.6mm) | | | |
| Cable/Wire Clearances | 0.5" (12.7mm) Required | | | | | | | | | | | |
| Mounting Restrictions | None | | | | | | | | | | | |
| Connecting Cables (Sold Separately) | ZL-DB9-CBL-2 See Connection Cable specifications tables at the end of this section. | | | | ZL-DB15-CBL-2 See Connection Cable specifications tables at the end of this section. | | | | ZL-DB25-CBL-2 See Connection Cable specifications tables at the end of this section. | | | |

* Use conductors rated for 60°/75°C.

**Connecting cables are for internal wiring only.

***Use Class 2 power supply.

Note: See wiring details and dimensional drawings on our Web site at:
<http://www.automationdirect.com/static/manuals/ziplinks/ziplinks.html>

RJ12 Feedthrough Module

The RJ12 feedthrough module provides convenient break-out of wiring to terminal blocks.

Module mounts on 35mm DIN rail part #DN-R35S1.



ZL-RTB-RJ12

| Specifications | | | | |
|--|---|---------|-----------|--------------|
| RJ12 Feedthrough Module | Part # | Pcs/Pkg | Price/Pkg | Weight (lbs) |
| | ZL-RTB-RJ12 | 1 | <---> | 0.32 |
| Description*** | RJ12 Connector to terminal block | | | |
| Approvals | File # E200031 UL, cUL, Class 1, Division 2, Groups A,B,C,D Hazardous Locations, CE, EN 61131-2:2007 | | | |
| UL Voltage Rating* | 30VDC | | | |
| Maximum Current per Circuit | 1A | | | |
| Number of Circuits | 6 | | | |
| Terminal Block Contacts | Copper alloy, tin-lead plated | | | |
| Wire Range (Rated Cross Section)** | 12-24AWG Solid or Stranded Copper Conductor (2.5mm ²) | | | |
| Wire Strip Length | 0.24-0.27" (6-7mm) | | | |
| Screw Torque | 4.4 in-lbs (0.5 Nm) | | | |
| Surrounding Temperature Range | 32 to 140°F (0 to 60°C) | | | |
| Dimensions (WxHxD) | 1.74" x 3.42" x 2.03" (44.1mm x 86.8mm x 51.6mm) | | | |
| Cable/Wire Clearance | 0.5" (12.7mm) Required | | | |
| Mounting Restrictions | None | | | |
| Connecting Cables (Sold Separately) | ZL-RJ12-CBL-2, ZL-RJ12-CBL-2P, GS-RJ12-CBL-2, ZL-SVC-232RJ12-CBL-2 See Connection Cable specifications tables at the end of this section. | | | |

* Use Class 2 power supply.

** Use conductors rated for 60°/75°C.

***Connecting cables are for internal wiring only.

Note: See wiring details and dimensional drawings on our Web site at:
<http://www.automationdirect.com/static/manuals/ziplinks/ziplinks.html>

Communication adaptors eliminate the hassle associated with connecting crimp or solder connectors to PLC communication ports. The communication adapters offer fast and convenient screw terminal connections for the DL06, D2-250-1 and D2-260 CPUs.

The ZL-CMA15L adapter offers transmit and receive LEDs, a jumper selectable network termination resistor, and circuit surge protection.



ZL-CMA15



ZL-CMA15L

| Specifications | | | | | | | | |
|---|--|----------|-----------|--------------|--|-----------|-----------|--------------|
| Communication Port Adapters | Part # | Pcs/Pkg | Price/Pkg | Weight (lbs) | Part # | Pcs/Pkg | Price/Pkg | Weight (lbs) |
| | | ZL-CMA15 | 1 | <---> | 0.04 | ZL-CMA15L | 1 | <---> |
| Description | DL06, D2-250-1 and D2-260 PLC Port 2 adapter: HD 15-pin D-sub to terminal block | | | | | | | |
| Approvals | File # E200031 Approved for use in Class 1 Division 2, Groups A, B, C, D Hazardous Locations | | | | | | | |
| Communications Interface | RS232, RS422, RS485 | | | | | | | |
| Indication Transmit Data | N/A | | | | Green LED | | | |
| Indication Receive Data | N/A | | | | Green LED | | | |
| RS232 Surge Protection | N/A | | | | 2 Circuits clamped by zener transient voltage suppressors | | | |
| RS422/485 Surge Protection | N/A | | | | 4 Circuits clamped by low capacitance zener diodes | | | |
| RS422/485 Network Termination Resistor | N/A | | | | Jumper Selectable 120Ω | | | |
| Voltage Rating* | 30VDC | | | | | | | |
| Maximum Current per Circuit | 1A | | | | | | | |
| Supported Signal Types | RS422/485 TXD+ RS422/485 RXD+ RS232 TXD, +5VDC PWR | | | | RS422/485 TXD- RS422/485 RXD- RS232 RXD Ground | | | |
| Terminal Block Contacts | Copper alloy, tin-lead plating | | | | | | | |
| Wire Range (Rated Cross Section)** | 16-30AWG Solid or Stranded Conductor (1.5mm ²) | | | | 16-28AWG Solid or Stranded Conductor (1.5mm ²) | | | |
| Wire Strip Length | 0.24-0.27" (6-7mm) | | | | | | | |
| Screw Torque | 1.7 in-lbs (0.2 Nm) | | | | | | | |
| Operating Temperature Range | 32 to 140°F (0 to 60°C) | | | | | | | |
| Dimensions (W x H x D) | 1.20" x 0.69" x 0.63" (30.5mm x 17.4 mm x 15.9mm) | | | | 1.31" x 0.64" x 2.72" (33.2mm x 16.2 mm x 69.2mm) | | | |

* Use Class 2 power supply.

** Use conductors rated for 60°/75°C.

ZL-CMA15

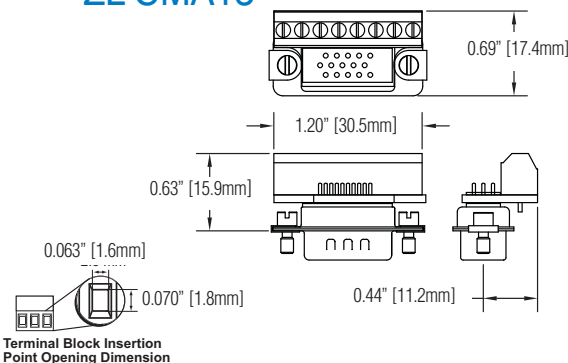

ZL-CMA15L

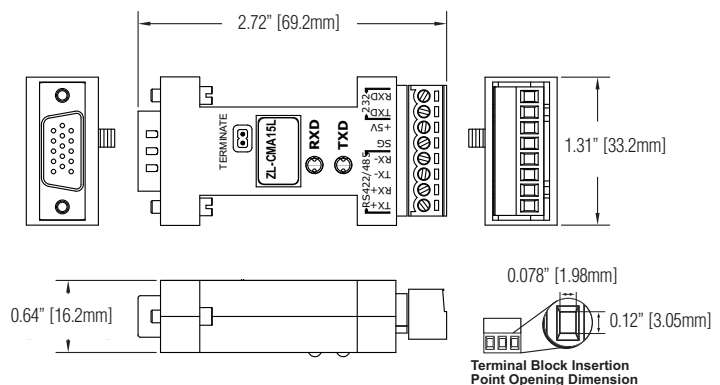

Note: See wiring details and dimensional drawings on our Web site at:
<http://www.automationdirect.com/static/manuals/ziplinks/ziplinks.html>

The RJ12 multi-port distribution modules allow for fast and convenient RS485 multi-drop connections.

Uses include serial network communication multi-drop to GS series drives, DuraPulse drives and SureServo drives.

Modules mount on 35 mm DIN rail part #DN-R35S1.



ZL-CDM-RJ12X4



ZL-CDM-RJ12X10

| Specifications | | | | | | | | |
|--|---|---------|-----------|--------------|--|---------|-----------|--------------|
| Communication Distribution Modules | Part # | Pcs/Pkg | Price/Pkg | Weight (lbs) | Part # | Pcs/Pkg | Price/Pkg | Weight (lbs) |
| | ZL-CDM-RJ12X4 | 1 | <--> | 0.14 | ZL-CDM-RJ12X10 | 1 | <--> | 0.23 |
| Description** | 4-port RJ12 Communication Distribution Module | | | | 10-port RJ12 Communication Distribution Module | | | |
| Approvals | File # E200031 UL, cUL, Class 1, Division 2, Groups A,B,C,D Hazardous Locations, CE, EN 61131-2:2007 | | | | | | | |
| Voltage Rating*** | 30VDC | | | | | | | |
| Maximum Current per Circuit | 1A | | | | | | | |
| Number of Circuits per RJ12 | 6 | | | | | | | |
| Terminal Block Contacts | Copper alloy, tin-lead plated | | | | | | | |
| Wire Range (Rated Cross Section)* | 12-24AWG Solid or Stranded Copper Conductor (2.5mm ²) | | | | | | | |
| Wire Strip Length | 0.24-0.27" (6-7mm) | | | | | | | |
| Screw Torque | 4.4 in-lbs (0.5 Nm) | | | | | | | |
| Connecting Cables (Sold Separately) | ZL-RJ12-CBL-2, ZL-RJ12-CBL-2P, GS-RJ12-CBL-2, ZL-SVC-232RJ12-CBL-2 See Connection Cable specifications tables at the end of this section. | | | | | | | |
| Surrounding Temperature Range | 32 to 140°F (0 to 60°C) | | | | | | | |
| Dimensions (WxHxD) | 1.56" x 3.42" x 1.65" (39.5mm x 86.8mm x 41.8mm) | | | | 2.88" x 3.42" x 1.65" (73.2mm x 86.8mm x 41.8mm) | | | |
| Cable/Wire Clearances | 0.5" (12.7mm) Required | | | | | | | |
| Mounting Restrictions | None | | | | | | | |

* Use conductors rated for 60°/75°C.

**Connecting cables are for internal wiring only.

***Use Class 2 power supply.

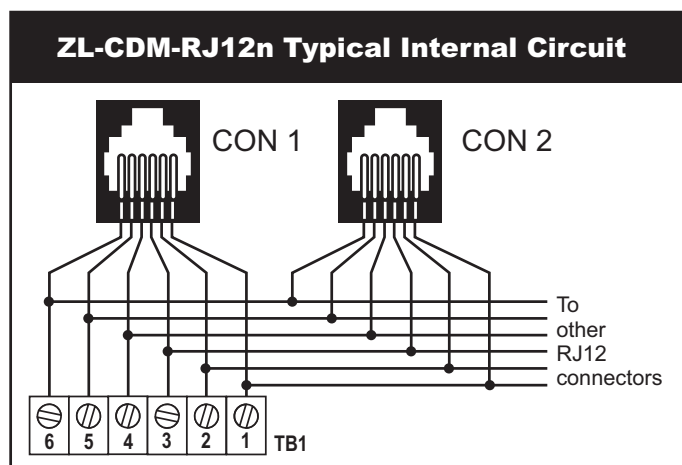
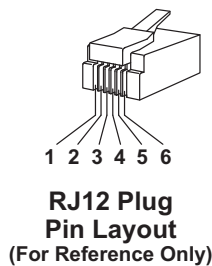

Note: See wiring details and dimensional drawings on our Web site at: <http://www.automationdirect.com/static/manuals/ziplinks/ziplinks.html>

Replacement Relays

Replacement relays are offered with a 24VDC coil or 120VAC coil and are for use with the ZIPLink relay modules.

Sold in packages of 4.



ZL-RELAY-24X4



ZL-RELAY-120X4



| 24VDC Relay Specifications | | | |
|------------------------------------|---|--|--|
| Contact | | Coil | |
| Current Rating | 30VDC @ 10A 250VAC @ 8A General Use | Input Voltage Range | 24VDC (-20%/+30%) |
| | | Maximum Continuous Coil Voltage | 31.2VDC |
| Contact Type | 1 Form C (SPDT) | Rated Current per Coil | 16.7mA (±10%) @ 24 VDC |
| Contact Voltage (per point) | 250VAC/30VDC | Coil Resistance | 1440Ω (±10%) |
| Maximum Power Inductive | 2000VA General Use | Power Consumption per Coil | 0.4W |
| Maximum Power Resistive | AC 2000VA, DC 300W | Pick Up Current Max. per Coil | 15mA |
| Maximum Switching Voltage | 250VAC, 110VDC | Drop-Out Voltage Min. | 1.2VDC |
| Minimum Load | 10mA @ 5VDC | Pick-Up Voltage Max. | 19.2VDC |
| Contact Resistance | 100mΩ Max @ 1A, 6VDC | Off to On/On to Off Response Time | 12ms/8ms |
| Contact Material | AgNi (Silver Nickel Alloy) | Weight (lbs) | 0.11 |
| 120VAC Relay Specifications | | | |
| Contact | | Coil | |
| Current Rating | 30VDC @ 10A 250VAC @ 8A General Use | Input Voltage Range | 115VAC (-20%/+30%), 50-60Hz |
| | | Maximum Continuous Coil Voltage | 150VAC |
| Contact Type | 1 Form C (SPDT) | Rated Current per Coil | 7.65mA (±10%) @ 115VAC 50Hz 6.30mA (±10%) @ 115VAC 60Hz |
| Contact Voltage (per point) | 250VAC/30VDC | Coil Resistance | 8100Ω (±10%) |
| Maximum Power Inductive | 2000VA General Use | Power Consumption per Coil | 0.88W @ 50Hz 0.73W @ 60Hz |
| Maximum Power Resistive | AC 2000VA, DC 300W | Drop-Out Voltage Min. | 34.5VAC |
| Maximum Switching Voltage | 250VAC, 110VDC | Pick-Up Voltage Max. | 92VAC |
| Minimum Load | 10mA @ 5VDC | Off to On/On to Off Response Time | 12ms/8ms |
| Contact Resistance | 100mΩ Max @ 1A, 6VDC | Weight (lbs) | 0.11 |
| Contact Material | AgNi (Silver Nickel Alloy) | | |

Installation Accessories

| Accessories | | | |
|-------------------------------|----------|---------|-----------|
| | Part # | Pcs/Pkg | Price/Pkg |
| DIN Rail | DN-R35S1 | 10 | <---> |
| Angled Support Bracket | DN-ASB1 | 50 | <---> |
| End Bracket | DN-EB35 | 50 | <---> |
| Slotted Screwdriver | DN-SS1 | 1 | <---> |

Module Dimensions

ZL-RTB20

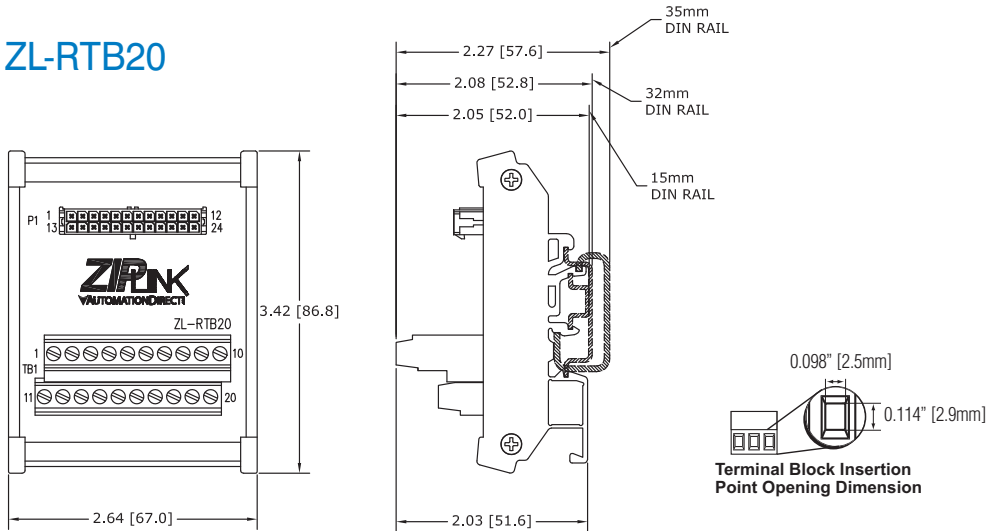

ZL-RTB40

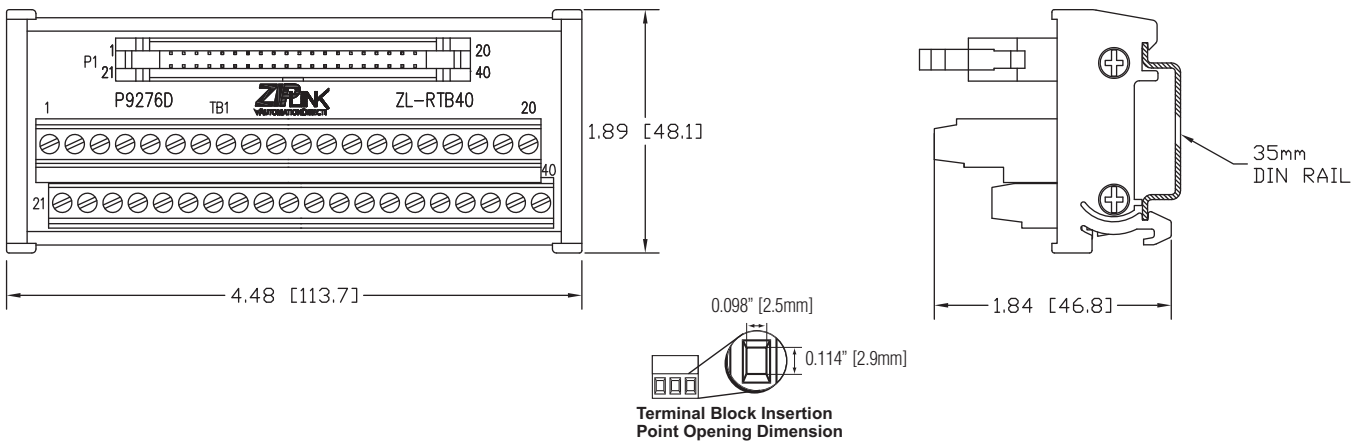

ZL-RTB50

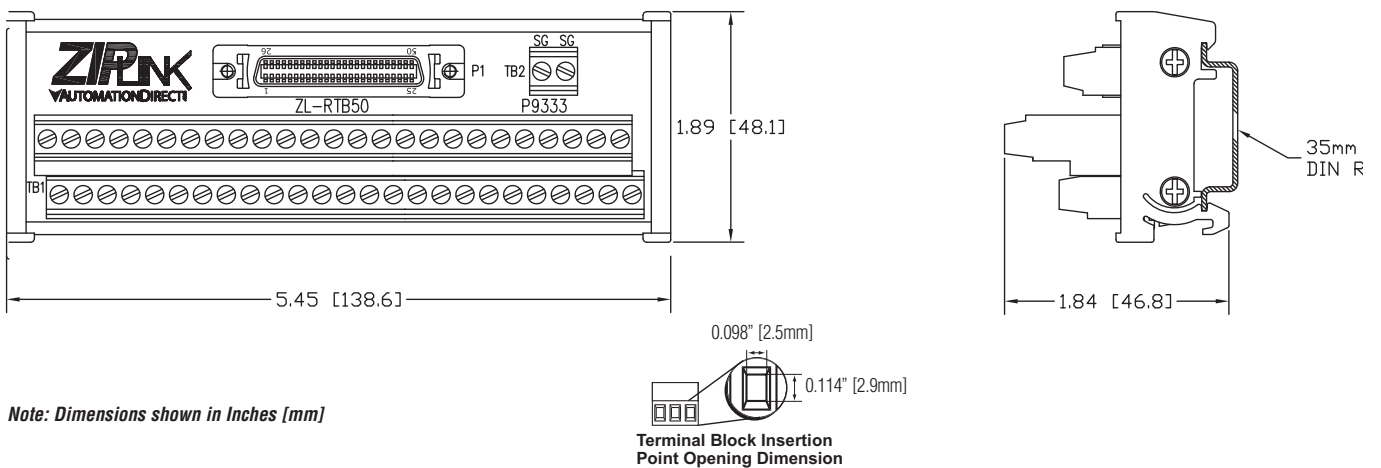

Note: Dimensions shown in Inches [mm]

ZL-RFU20

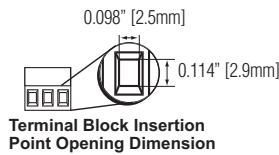
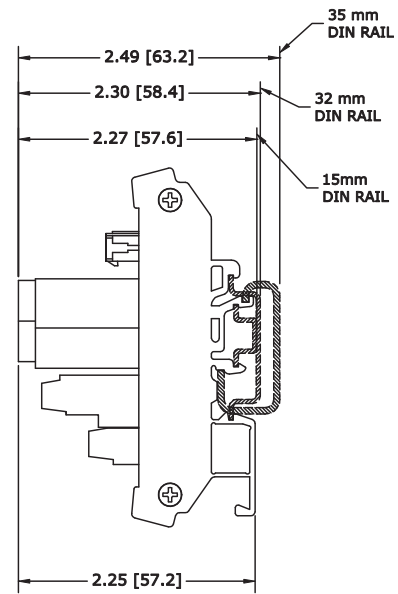
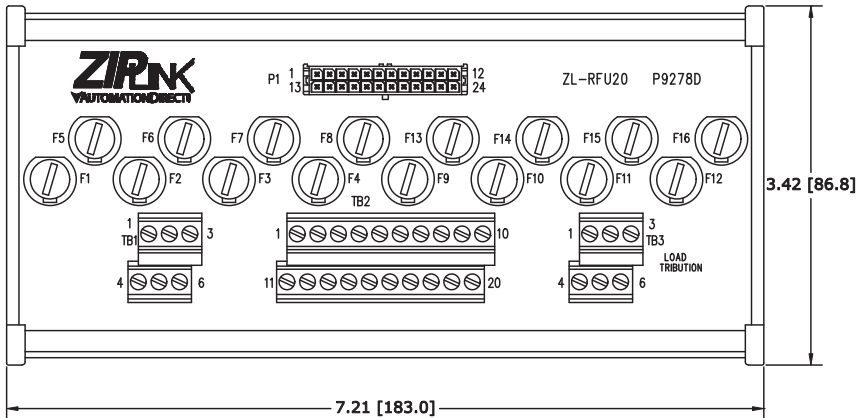

ZL-RFU40

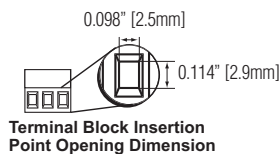
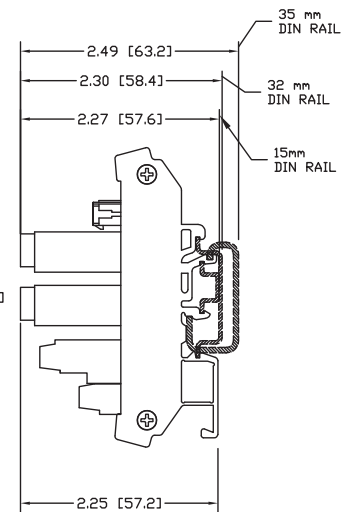
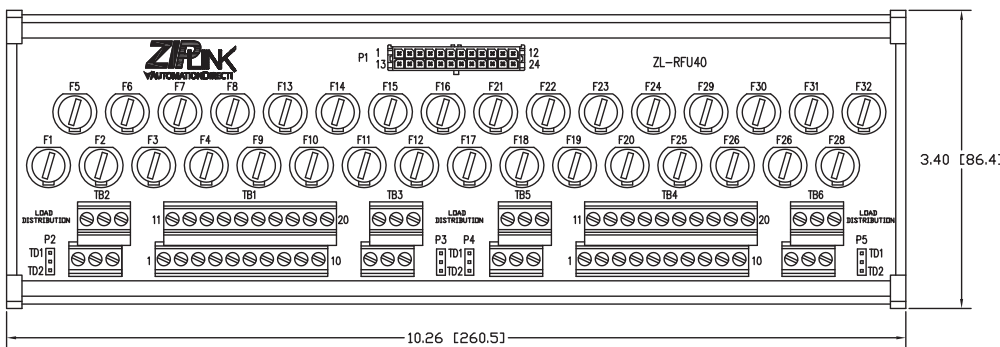

Note: Dimensions shown in Inches [mm]

Module Dimensions

ZL-RRL16-24-1 ZL-RRL16-24-2

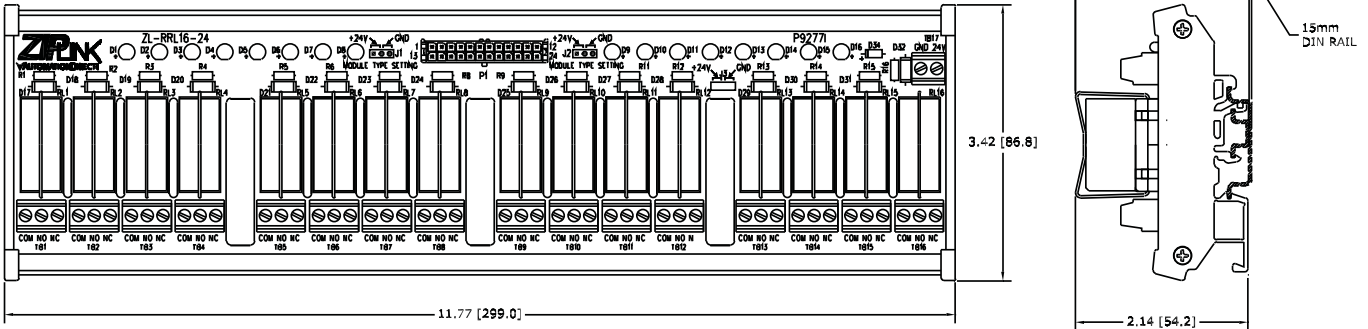

ZL-RLS1-24(120)

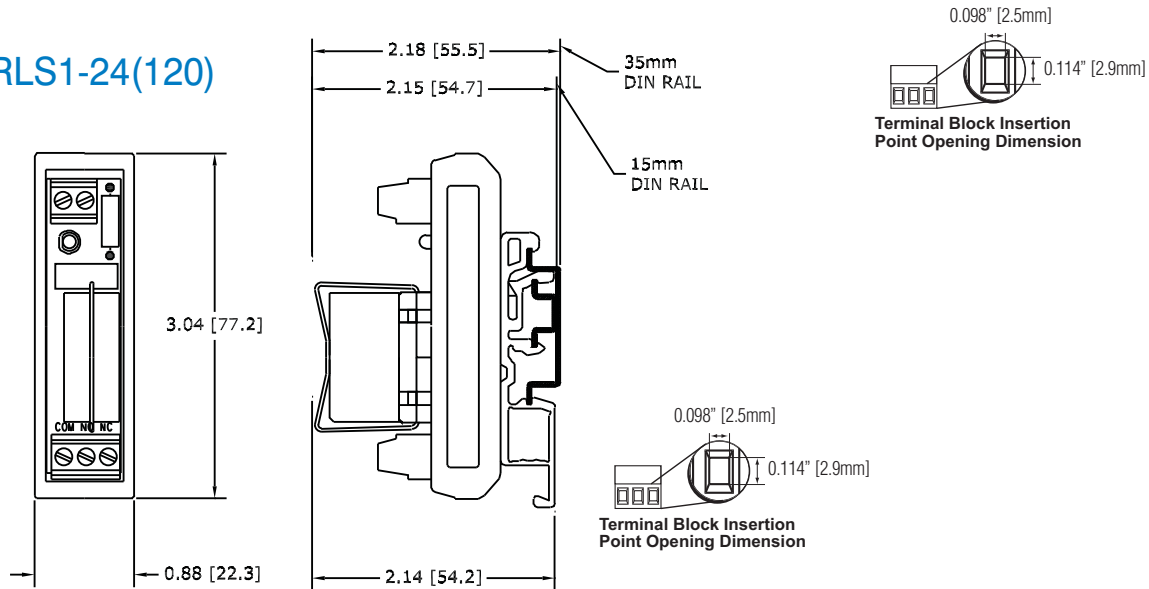

ZL-RLS4-24(120)

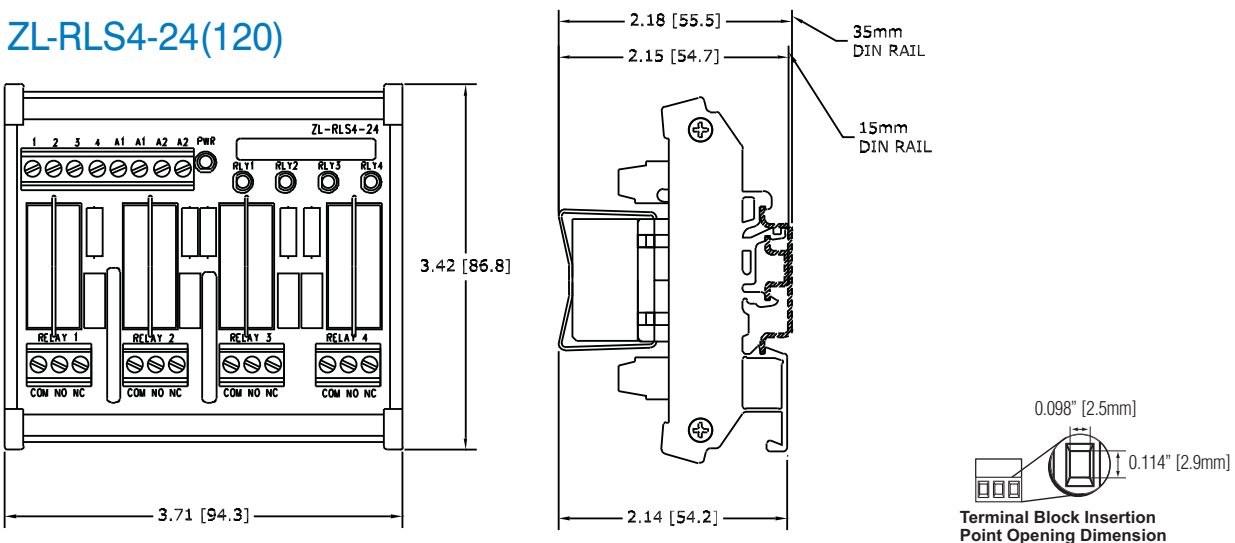

Note: Dimensions shown in Inches [mm]

Volume 14

ZL-LTB16-24

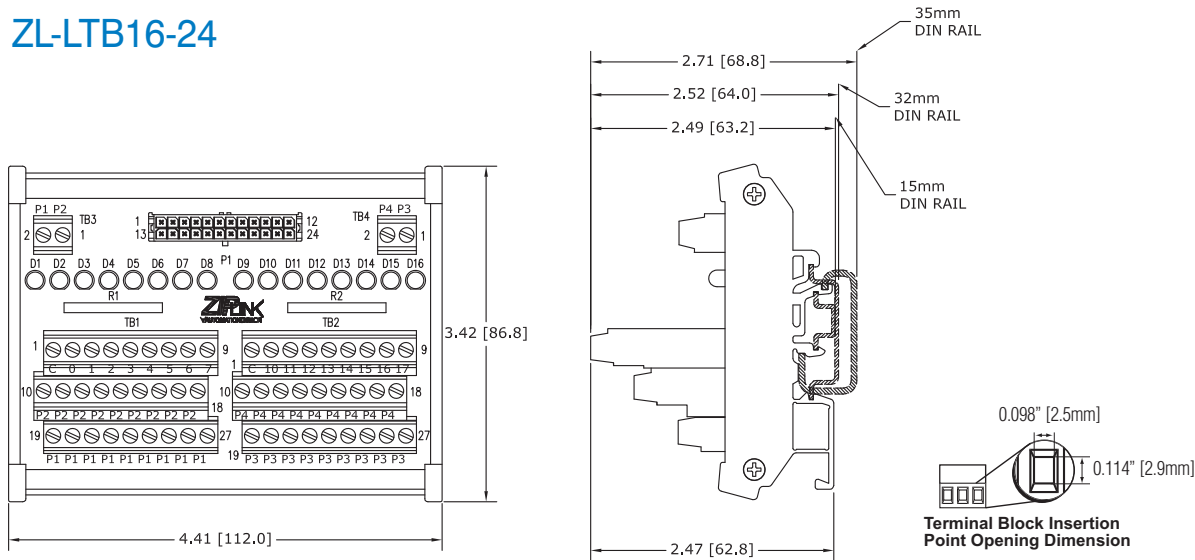

ZL-LTB32-24

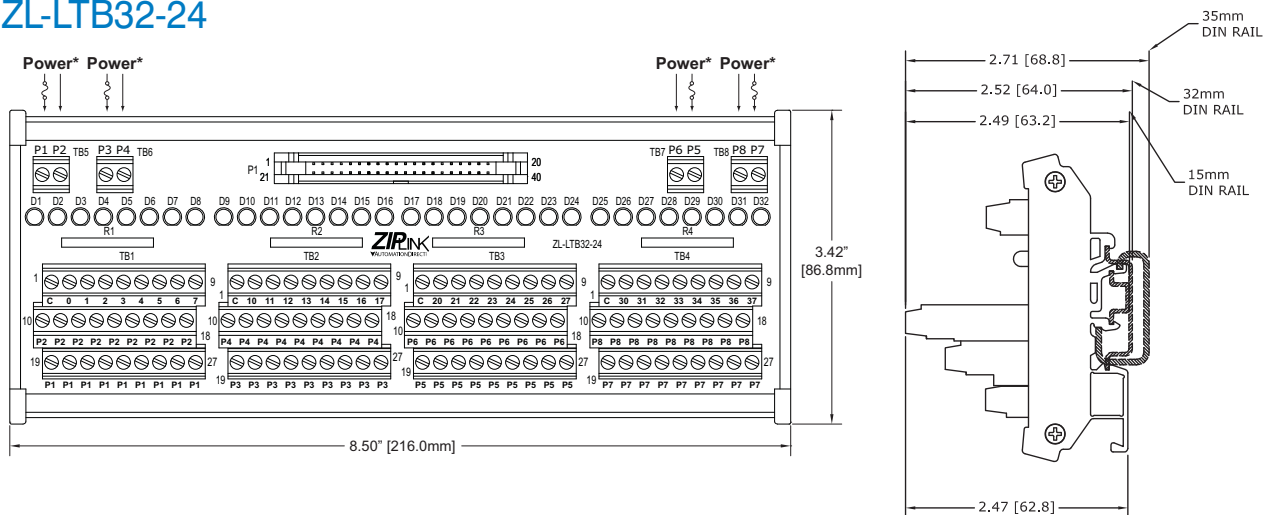

ZL-TSD8-24(120)

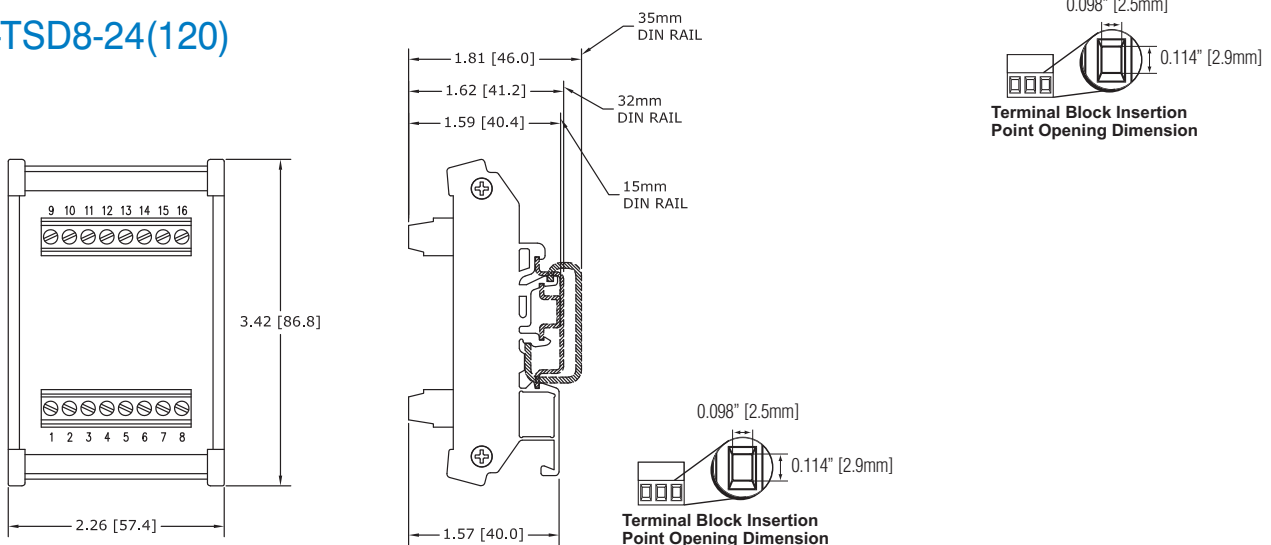

Note: Dimensions shown in Inches [mm]

Module Dimensions

ZL-RTB-DB09/15/25

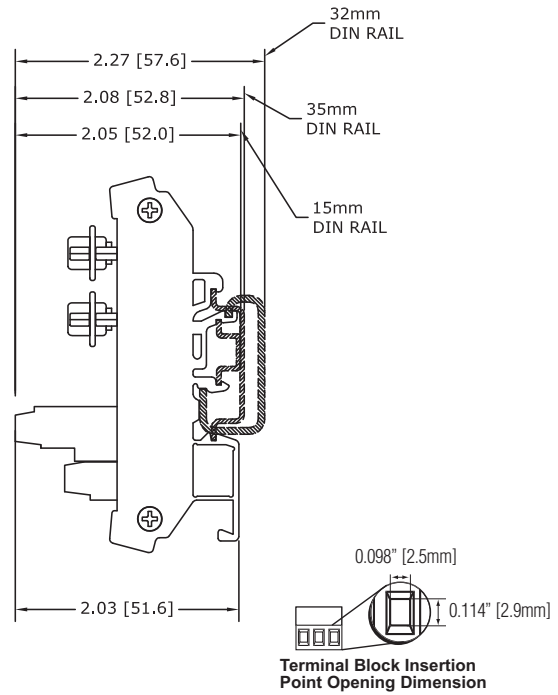
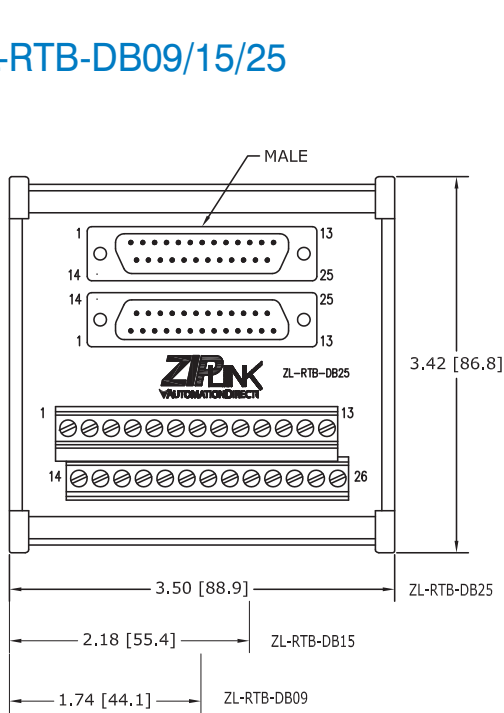

ZL-RTB-RJ12

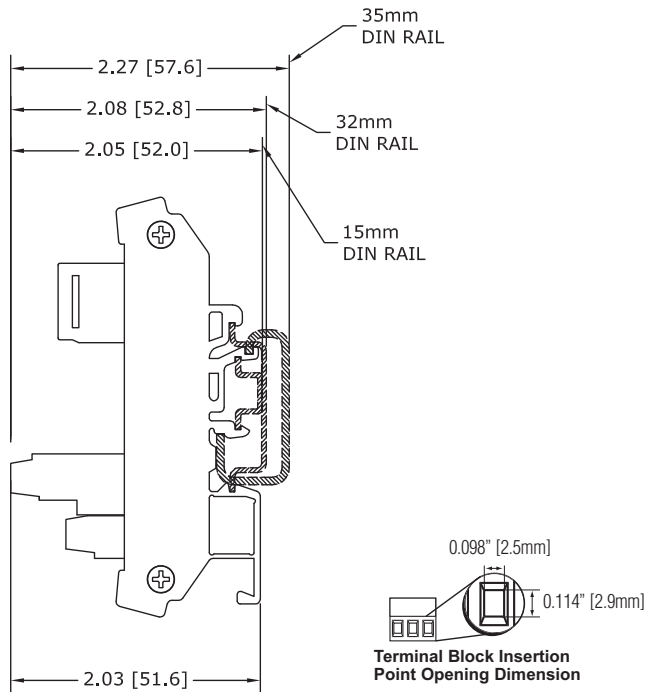
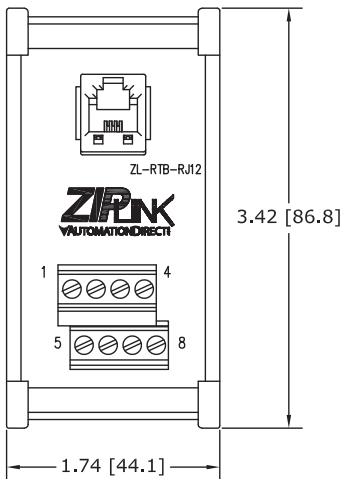

Note: Dimensions shown in Inches [mm]

Module Dimensions

ZL-CDM-RJ12X4

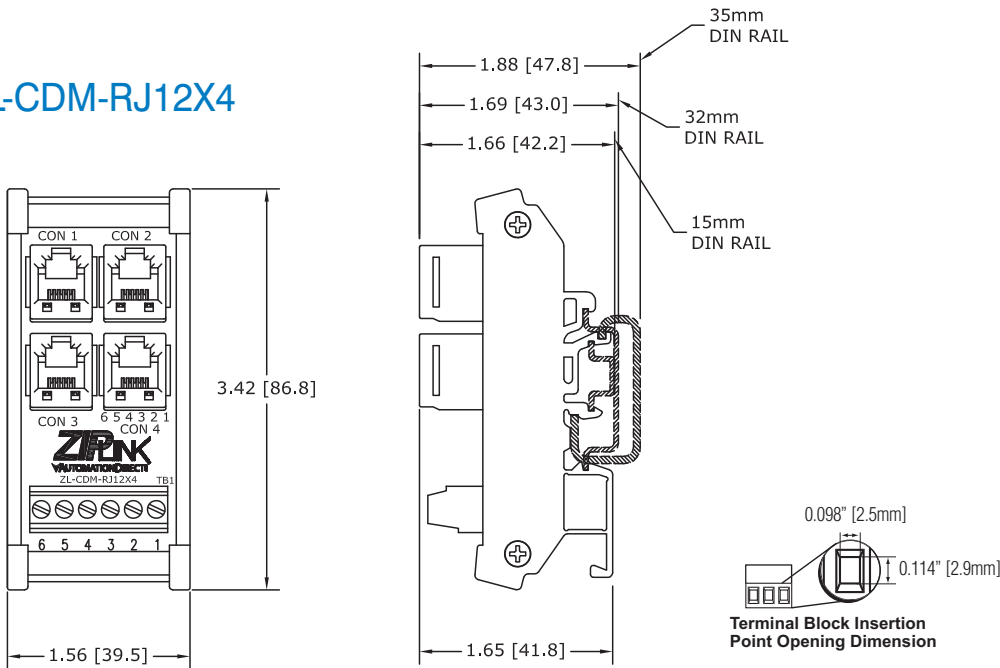

ZL-CDM-RJ12X10

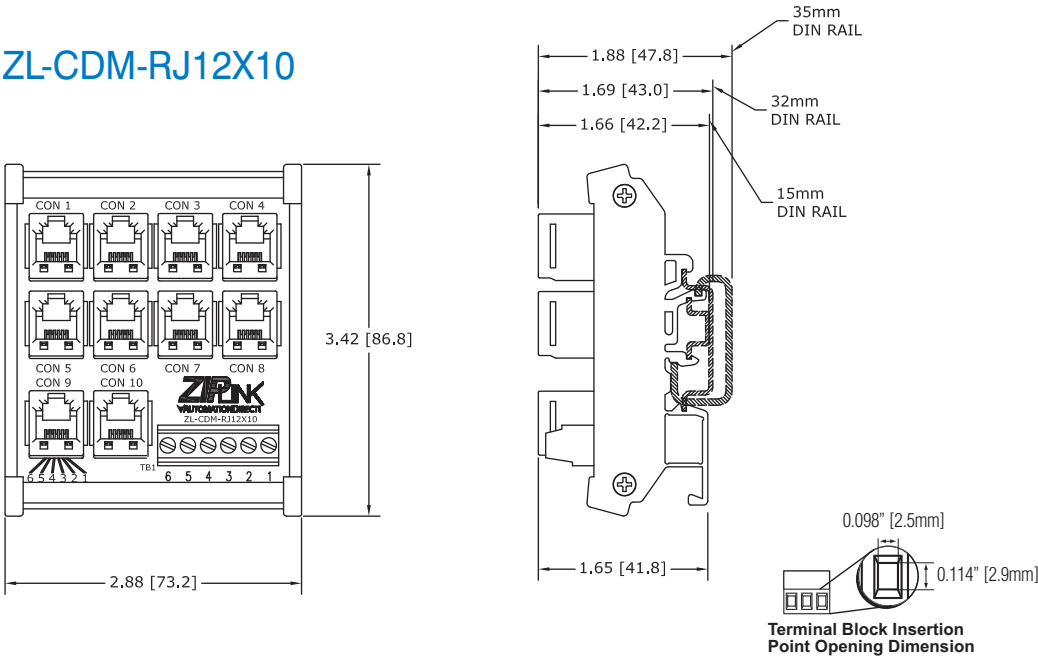

Note: Dimensions shown in Inches [mm]

Approvals

- UL Recognized, UL file E157382
- CE Marked LVD 2006/95/EC
- RoHS Compliant



| ZIPLink Connection Cables | | | | |
|-------------------------------------|---|-------------------|--------------|-------|
| Part Number | Description | Insulation Rating | Weight (lbs) | Price |
| CLICK ZIPLink Cables | | | | |
| ZL-CO-CBL11 | Cable for module with 11 terminals to 24-pin connector, 24 AWG, 1.6 ft. (0.5m) | 300V, 80°C | 0.21 | <---> |
| ZL-CO-CBL11-1 | Cable for module with 11 terminals to 24-pin connector, 24 AWG, 3.3 ft. (1.0m) | 300V, 80°C | 0.31 | <---> |
| ZL-CO-CBL11-2 | Cable for module with 11 terminals to 24-pin connector, 24 AWG, 6.6 ft. (2.0m) | 300V, 80°C | 0.56 | <---> |
| ZL-CO-CBL11-1P | Cable for module with 11 terminals to pigtail, 24 AWG, 3.3 ft. (1.0m) | 300V, 80°C | 0.21 | <---> |
| ZL-CO-CBL11-2P | Cable for module with 11 terminals to pigtail, 24 AWG, 6.6 ft. (2.0m) | 300V, 80°C | 0.26 | <---> |
| ZL-CO-CBL20 | Cable for module with 20 terminals to 24-pin connector, 24 AWG, 1.6 ft. (0.5m) | 300V, 80°C | 0.25 | <---> |
| ZL-CO-CBL20-1 | Cable for module with 20 terminals to 24-pin connector, 24 AWG, 3.3 ft. (1.0m) | 300V, 80°C | 0.31 | <---> |
| ZL-CO-CBL20-2 | Cable for module with 20 terminals to 24-pin connector, 24 AWG, 6.6 ft. (2.0m) | 300V, 80°C | 0.61 | <---> |
| ZL-CO-CBL20-1P | Cable for module with 20 terminals to pigtail, 24 AWG, 3.3 ft. (1.0m) | 300V, 80°C | 0.21 | <---> |
| ZL-CO-CBL20-2P | Cable for module with 20 terminals to pigtail, 24 AWG, 6.6 ft. (2.0m) | 300V, 80°C | 0.26 | <---> |
| DL05 and DL06 ZIPLink Cables | | | | |
| ZL-DO-CBL8 | Cable for module with 8 terminals to 24-pin connector, 24 AWG, 1.6 ft. (0.5m) | 300V, 80°C | 0.26 | <---> |
| ZL-DO-CBL8-1 | Cable for module with 8 terminals to 24-pin connector, 24 AWG, 3.3 ft. (1.0m) | 300V, 80°C | 0.36 | <---> |
| ZL-DO-CBL8-2 | Cable for module with 8 terminals to 24-pin connector, 24 AWG, 6.6 ft. (2.0m) | 300V, 80°C | 0.56 | <---> |
| ZL-DO-CBL8-1P | Cable for module with 8-pin connector to pigtail, 24 AWG, 3.3 ft. (1.0m) | 300V, 80°C | 0.21 | <---> |
| ZL-DO-CBL8-2P | Cable for module with 8-pin connector to pigtail, 24 AWG, 6.6 ft. (2.0m) | 300V, 80°C | 0.26 | <---> |
| ZL-DO-CBL10 | Cable for module with 10 terminals to 24-pin connector, 24 AWG, 1.6 ft. (0.5m) | 300V, 80°C | 0.26 | <---> |
| ZL-DO-CBL10-1 | Cable for module with 10 terminals to 24-pin connector, 24 AWG, 3.3 ft. (1.0m) | 300V, 80°C | 0.36 | <---> |
| ZL-DO-CBL10-2 | Cable for module with 10 terminals to 24-pin connector, 24 AWG, 6.6 ft. (2.0m) | 300V, 80°C | 0.56 | <---> |
| ZL-DO-CBL10-1P | Cable for module with 10-pin connector to pigtail, 24 AWG, 3.3 ft. (1.0m) | 300V, 80°C | 0.21 | <---> |
| ZL-DO-CBL10-2P | Cable for module with 10-pin connector to pigtail, 24 AWG, 6.6 ft. (2.0m) | 300V, 80°C | 0.26 | <---> |
| ZL-DO-CBL13 | Cable for module with 13 terminals to 24-pin connector, 24 AWG, 1.6 ft. (0.5m) | 300V, 80°C | 0.26 | <---> |
| ZL-DO-CBL13-1 | Cable for module with 13 terminals to 24-pin connector, 24 AWG, 3.3 ft. (1.0m) | 300V, 80°C | 0.36 | <---> |
| ZL-DO-CBL13-2 | Cable for module with 13 terminals to 24-pin connector, 24 AWG, 6.6 ft. (2.0m) | 300V, 80°C | 0.56 | <---> |
| ZL-DO-CBL13-1P | Cable for module with 13-pin connector to pigtail, 24 AWG, 3.3 ft. (1.0m) | 300V, 80°C | 0.21 | <---> |
| ZL-DO-CBL13-2P | Cable for module with 13-pin connector to pigtail, 24 AWG, 6.6 ft. (2.0m) | 300V, 80°C | 0.26 | <---> |
| ZL-DO-CBL24 | Cable for module with 24-pin connector to 24-pin connector, 24 AWG, 1.6 ft. (0.5m) | 300V, 80°C | 0.26 | <---> |
| ZL-DO-CBL24-1 | Cable for module with 24-pin connector to 24-pin connector, 24 AWG, 3.3 ft. (1.0m) | 300V, 80°C | 0.36 | <---> |
| ZL-DO-CBL24-2 | Cable for module with 24-pin connector to 24-pin connector, 24 AWG, 6.6 ft. (2.0m) | 300V, 80°C | 0.56 | <---> |
| ZL-DO-CBL24-L | Cable for module with 24-pin connector to 24-pin connector for LED module, 24 AWG, 1.6 ft. (0.5m) | 300V, 80°C | 0.26 | <---> |
| ZL-DO-CBL24-1L | Cable for module with 24-pin connector to 24-pin connector for LED module, 24 AWG, 3.3 ft. (1.0m) | 300V, 80°C | 0.36 | <---> |
| ZL-DO-CBL24-2L | Cable for module with 24-pin connector to 24-pin connector for LED module, 24 AWG, 6.6 ft. (2.0m) | 300V, 80°C | 0.56 | <---> |
| ZL-DO-CBL24-1P | Cable for module with 24-pin connector to 24-wire pigtail, 24 AWG, 3.3 ft. (1.0m) | 300V, 80°C | 0.26 | <---> |
| ZL-DO-CBL24-2P | Cable for module with 24-pin connector to 24-wire pigtail, 24 AWG, 6.6 ft. (2.0m) | 300V, 80°C | 0.56 | <---> |



ZL-CO-CBL11



ZL-DO-CBL10-1



ZL-DO-CBL24-1



ZL-DO-CBL24-1P

| ZIPLink Connection Cables | | | | |
|--|--|-------------------|--------------|-------|
| Part Number | Description | Insulation Rating | Weight (lbs) | Price |
| DL05 and DL06 ZIPLink Cables, continued | | | | |
| ZL-D06X-CBL20 | Cable used to connect DirectLOGIC 06 PLC fixed inputs with 20 terminals to the ZL-RTB20 ZIPLink module with a 24-pin connector, can be used on the input side terminal block only, 24AWG, 1.6 ft. (0.5m) | 300V, 80°C | 0.36 | <---> |
| ZL-D06X-CBL20-1 | Cable used to connect DirectLOGIC 06 PLC fixed inputs with 20 terminals to the ZL-RTB20 ZIPLink module with a 24-pin connector, can be used on the input side terminal block only, 24AWG, 3.3 ft. (1.0m) | 300V, 80°C | 0.46 | <---> |
| ZL-D06X-CBL20-2 | Cable used to connect DirectLOGIC 06 PLC fixed inputs with 20 terminals to the ZL-RTB20 ZIPLink module with a 24-pin connector, can be used on the input side terminal block only, 24AWG, 6.6 ft. (2.0m) | 300V, 80°C | 0.56 | <---> |
| ZL-D06Y-CBL20 | Cable used to connect DirectLOGIC 06 PLC fixed outputs with 20 terminals to the ZL-RTB20 ZIPLink module with a 24-pin connector, can be used on the output side terminal block only, 24AWG, 1.6 ft. (0.5m) | 300V, 80°C | 0.36 | <---> |
| ZL-D06Y-CBL20-1 | Cable used to connect DirectLOGIC 06 PLC fixed outputs with 20 terminals to the ZL-RTB20 ZIPLink module with a 24-pin connector, can be used on the output side terminal block only, 24AWG, 3.3 ft. (1.0m) | 300V, 80°C | 0.46 | <---> |
| ZL-D06Y-CBL20-2 | Cable used to connect DirectLOGIC 06 PLC fixed outputs with 20 terminals to the ZL-RTB20 ZIPLink module with a 24-pin connector, can be used on the output side terminal block only, 24AWG, 6.6 ft. (2.0m) | 300V, 80°C | 0.56 | <---> |
| ZL-D06-CBL24-1P | Cable that allows DirectLOGIC 06 PLC fixed I/O with 24 terminals to custom wire to third party devices, can be used on the input side terminal block or the output side terminal block of the DL06, 24AWG, 3.3 ft. (1.0m) | 300V, 80°C | 0.36 | <---> |
| ZL-D06-CBL24-2P | Cable that allows DirectLOGIC 06 PLC fixed I/O with 24 terminals to custom wire to third party devices, can be used on the input side terminal block or the output side terminal block of the DL06, 24AWG, 6.6 ft. (2.0m) | 300V, 80°C | 0.46 | <---> |
| ZL-D05-CBL18 | Cable used to connect DirectLOGIC 05 PLC fixed I/O with 18 terminals to the ZL-RTB20 ZIPLink module with a 24-pin connector, can be used on the input side terminal block or the output side terminal block of the DL05, 24AWG, 1.6 ft. (0.5m) | 300V, 80°C | 0.36 | <---> |
| ZL-D05-CBL18-1 | Cable used to connect DirectLOGIC 05 PLC fixed I/O with 18 terminals to the ZL-RTB20 ZIPLink module with a 24-pin connector, can be used on the input side terminal block or the output side terminal block of the DL05, 24AWG, 3.3 ft. (1.0m) | 300V, 80°C | 0.46 | <---> |
| ZL-D05-CBL18-2 | Cable used to connect DirectLOGIC 05 PLC fixed I/O with 18 terminals to the ZL-RTB20 ZIPLink module with a 24-pin connector, can be used on the input side terminal block or the output side terminal block of the DL05, 24AWG, 6.6 ft. (2.0m) | 300V, 80°C | 0.56 | <---> |
| ZL-D05-CBL22-1P | Cable that allows DirectLOGIC 05 PLC fixed I/O with 20 terminals to custom wire to third party devices, can be used on the input side terminal block or the output side terminal block of the DL05, 24AWG, 3.3 ft. (1.0m) | 300V, 80°C | 0.32 | <---> |
| ZL-D05-CBL22-2P | Cable that allows DirectLOGIC 05 PLC fixed I/O with 20 terminals to custom wire to third party devices, can be used on the input side terminal block or the output side terminal block of the DL05, 24AWG, 6.6 ft. (2.0m) | 300V, 80°C | 0.46 | <---> |
| DL205 ZIPLink Cables | | | | |
| ZL-D2-CBL10 | Cable for module with 10 terminals to 24-pin connector, 24 AWG, 1.6 ft. (0.5m) | 300V, 80°C | 0.36 | <---> |
| ZL-D2-CBL10-1 | Cable for module with 10 terminals to 24-pin connector, 24 AWG, 3.3 ft. (1.0m) | 300V, 80°C | 0.61 | <---> |
| ZL-D2-CBL10-2 | Cable for module with 10 terminals to 24-pin connector, 24 AWG, 6.6 ft. (2.0m) | 300V, 80°C | 0.61 | <---> |
| ZL-D2-CBL10-1P | Cable for module with 10 terminals to pigtail, 24AWG, 3.3 ft. (1.0m) | 300V, 80°C | 0.31 | <---> |
| ZL-D2-CBL10-2P | Cable for module with 10 terminals to pigtail, 24AWG, 6.6 ft. (2.0m) | 300V, 80°C | 0.46 | <---> |
| ZL-D2-CBL19 | Cable for module with 19 terminals to 24-pin connector, 24 AWG, 1.6 ft. (0.5m) | 300V, 80°C | 0.36 | <---> |
| ZL-D2-CBL19-1 | Cable for module with 19 terminals to 24-pin connector, 24 AWG, 3.3 ft. (1.0m) | 300V, 80°C | 0.61 | <---> |
| ZL-D2-CBL19-2 | Cable for module with 19 terminals to 24-pin connector, 24 AWG, 6.6 ft. (2.0m) | 300V, 80°C | 0.61 | <---> |
| ZL-D2-CBL19-1P | Cable for module with 19 terminals to pigtail, 24AWG, 3.3 ft. (1.0m) | 300V, 80°C | 0.61 | <---> |
| ZL-D2-CBL19-2P | Cable for module with 19 terminals to pigtail, 24AWG, 6.6 ft. (2.0m) | 300V, 80°C | 0.61 | <---> |
| ZL-D24-CBL40 | Cable w/180° plug for module with 40-pin connector to 40-pin connector, 24 AWG, 1.6 ft. (0.5m) | 300V, 80°C | 0.36 | <---> |
| ZL-D24-CBL40-1 | Cable w/180° plug for module with 40-pin connector to 40-pin connector, 24 AWG, 3.3 ft. (1.0m) | 300V, 80°C | 0.61 | <---> |
| ZL-D24-CBL40-2 | Cable w/180° plug for module with 40-pin connector to 40-pin connector, 24 AWG, 6.6 ft. (2.0m) | 300V, 80°C | 0.61 | <---> |
| ZL-D24-CBL40-X | Cable w/45° plug for module with 40-pin connector to 40-pin connector, 24 AWG, 1.6 ft. (0.5m) | 300V, 80°C | 0.36 | <---> |
| ZL-D24-CBL40-1X | Cable w/45° plug for module with 40-pin connector to 40-pin connector, 24 AWG, 3.3 ft. (1.0m) | 300V, 80°C | 0.61 | <---> |
| ZL-D24-CBL40-2X | Cable w/45° plug for module with 40-pin connector to 40-pin connector, 24 AWG, 6.6 ft. (2.0m) | 300V, 80°C | 0.61 | <---> |



ZL-D06X-CBL20



ZL-D2-CBL10



ZL-D24-CBL40



ZL-D2-CBL19-1P

| ZIPLink Connection Cables | | | | |
|--|--|-------------------|--------------|-------|
| Part Number | Description | Insulation Rating | Weight (lbs) | Price |
| DL205 ZIPLink Cables, continued | | | | |
| ZL-D24-CBL40-1P | Cable w/180° plug for module with 40-pin connector to 40-wire pigtail, 24 AWG, 3.3 ft. (1.0m) | 300V, 80°C | 0.56 | <---> |
| ZL-D24-CBL40-2P | Cable w/180° plug for module with 40-pin connector to 40-wire pigtail, 24 AWG, 6.6 ft. (2.0m) | 300V, 80°C | 0.61 | <---> |
| ZL-D24-CBL40-1XP | Cable w/45° plug for module with 40-pin connector to 40-wire pigtail, 24 AWG, 3.3 ft. (1.0m) | 300V, 80°C | 0.56 | <---> |
| ZL-D24-CBL40-2XP | Cable w/45° plug for module with 40-pin connector to 40-wire pigtail, 24 AWG, 6.6 ft. (2.0m) | 300V, 80°C | 0.61 | <---> |
| ZL-D24-CON-R | ZIPLink ribbon-style connector, 40-pin, qty. 2 | N/A | 0.36 | <---> |
| ZL-D24-CON | ZIPLink solder-style connector, 180°, 40-pin, qty. 2 | N/A | 0.36 | <---> |
| ZL-D24-CON-X | ZIPLink solder-style connector, 105°, 40-pin, qty. 2 | N/A | 0.36 | <---> |
| DL305 ZIPLink Cables | | | | |
| ZL-D3-CBL18 | Cable for module with 18 terminals to 24-pin connector, 24 AWG, 1.6 ft. (0.5m) | 300V, 80°C | 0.36 | <---> |
| ZL-D3-CBL18-1 | Cable for module with 18 terminals to 24-pin connector, 24 AWG, 3.3 ft. (1.0m) | 300V, 80°C | 0.56 | <---> |
| ZL-D3-CBL18-2 | Cable for module with 18 terminals to 24-pin connector, 24 AWG, 6.6 ft. (2.0m) | 300V, 80°C | 0.61 | <---> |
| DL405 ZIPLink Cables | | | | |
| ZL-D4-CBL20 | Cable for module with 20 terminals to 24-pin connector, 24 AWG, 1.6 ft. (0.5m) | 300V, 80°C | 0.36 | <---> |
| ZL-D4-CBL20-1 | Cable for module with 20 terminals to 24-pin connector, 24 AWG, 3.3 ft. (1.0m) | 300V, 80°C | 0.56 | <---> |
| ZL-D4-CBL20-2 | Cable for module with 20 terminals to 24-pin connector, 24 AWG, 6.6 ft. (2.0m) | 300V, 80°C | 0.61 | <---> |
| ZL-D4-CBL20-1P | Cable for module with 20 terminals to pigtail, 24 AWG, 3.3 ft. (1.0m) | 300V, 80°C | 0.42 | <---> |
| ZL-D4-CBL20-2P | Cable for module with 20 terminals to pigtail, 24 AWG, 6.6 ft. (2.0m) | 300V, 80°C | 0.56 | <---> |
| ZL-D24-CBL40 | Cable w/180° plug for module with 40-pin connector to 40-pin connector, 24 AWG, 1.6 ft. (0.5m) | 300V, 80°C | 0.36 | <---> |
| ZL-D24-CBL40-1 | Cable w/180° plug for module with 40-pin connector to 40-pin connector, 24 AWG, 3.3 ft. (1.0m) | 300V, 80°C | 0.56 | <---> |
| ZL-D24-CBL40-2 | Cable w/180° plug for module with 40-pin connector to 40-pin connector, 24 AWG, 6.6 ft. (2.0m) | 300V, 80°C | 0.61 | <---> |
| ZL-D24-CBL40-X | Cable w/45° plug for module with 40-pin connector to 40-pin connector, 24 AWG, 1.6 ft. (0.5m) | 300V, 80°C | 0.36 | <---> |
| ZL-D24-CBL40-1X | Cable w/45° plug for module with 40-pin connector to 40-pin connector, 24 AWG, 3.3 ft. (1.0m) | 300V, 80°C | 0.56 | <---> |
| ZL-D24-CBL40-2X | Cable w/45° plug for module with 40-pin connector to 40-pin connector, 24 AWG, 6.6 ft. (2.0m) | 300V, 80°C | 0.61 | <---> |
| ZL-D24-CBL40-1P | Cable w/180° plug for module with 40-pin connector to 40-wire pigtail, 24 AWG, 3.3 ft. (1.0m) | 300V, 80°C | 0.56 | <---> |
| ZL-D24-CBL40-2P | Cable w/180° plug for module with 40-pin connector to 40-wire pigtail, 24 AWG, 6.6 ft. (2.0m) | 300V, 80°C | 0.61 | <---> |
| ZL-D24-CBL40-1XP | Cable w/45° plug for module with 40-pin connector to 40-wire pigtail, 24 AWG, 3.3 ft. (1.0m) | 300V, 80°C | 0.56 | <---> |
| ZL-D24-CBL40-2XP | Cable w/45° plug for module with 40-pin connector to 40-wire pigtail, 24 AWG, 6.6 ft. (2.0m) | 300V, 80°C | 0.61 | <---> |
| ZL-D24-CON-R | ZIPLink ribbon-style connector, 40-pin, qty. 2 | N/A | 0.36 | <---> |
| ZL-D24-CON | ZIPLink solder-style connector, 180°, 40-pin, qty. 2 | N/A | 0.36 | <---> |
| ZL-D24-CON-X | ZIPLink solder-style connector, 45°, 40-pin, qty. 2 | N/A | 0.36 | <---> |



ZL-D24-CBL40-1P



ZL-D4-CBL20



ZL-D3-CBL18



ZL-D24-CBL40-1XP



ZL-D24-CON Parts

| ZIPLink Connection Cables | | | | |
|--|---|-------------------|--------------|-------|
| Part Number | Description | Insulation Rating | Weight (lbs) | Price |
| Productivity3000 ZIPLink Cables | | | | |
| ZL-P3-CBL20 | Cable for module with 20 terminals to 20-pin connector, 24 AWG, 1.6 ft. (0.5m) | 300V, 80°C | 0.36 | <---> |
| ZL-P3-CBL20-1 | Cable for module with 20 terminals to 20-pin connector, 24 AWG, 3.3 ft. (1.0m) | 300V, 80°C | 0.36 | <---> |
| ZL-P3-CBL20-2 | Cable for module with 20 terminals to 20-pin connector, 24 AWG, 6.6 ft. (2.0m) | 300V, 80°C | 0.56 | <---> |
| ZL-P3-CBL20-L | Cable for module with 20-pin connector to 20-pin connector for LED module, 24 AWG, 1.6 ft. (0.5m) | 300V, 80°C | 0.36 | <---> |
| ZL-P3-CBL20-1L | Cable for module with 20-pin connector to 20-pin connector for LED module, 24 AWG, 3.3 ft. (1.0m) | 300V, 80°C | 0.36 | <---> |
| ZL-P3-CBL20-2L | Cable for module with 20-pin connector to 20-pin connector for LED module, 24 AWG, 6.6 ft. (2.0m) | 300V, 80°C | 0.56 | <---> |
| ZL-P3-CBL20-P | Cable for module with 20-pin connector to 20-wire pigtail, 24 AWG, 1.6 ft. (0.5m) | 300V, 80°C | 0.36 | <---> |
| ZL-P3-CBL20-1P | Cable for module with 20-pin connector to 20-wire pigtail, 24 AWG, 3.3 ft. (1.0m) | 300V, 80°C | 0.56 | <---> |
| ZL-P3-CBL20-2P | Cable for module with 20-pin connector to 20-wire pigtail, 24 AWG, 6.6 ft. (2.0m) | 300V, 80°C | 0.61 | <---> |
| ZL-CBL40 | Cable for module with 40-pin connector to 40-pin connector, 24 AWG, 1.6 ft. (0.5m) | 300V, 80°C | 0.36 | <---> |
| ZL-CBL40-1 | Cable for module with 40-pin connector to 40-pin connector, 24 AWG, 3.3 ft. (1.0m) | 300V, 80°C | 0.56 | <---> |
| ZL-CBL40-2 | Cable for module with 40-pin connector to 40-pin connector, 24 AWG, 6.6 ft. (2.0m) | 300V, 80°C | 0.61 | <---> |
| ZL-CBL40-S | Cable for module with 40-pin connector to 40-pin connector, shielded, 24 AWG, 1.6 ft. (0.5m) (High-Speed I/O modules only) | 300V, 80°C | 0.4 | <---> |
| ZL-CBL40-1S | Cable for module with 40-pin connector to 40-pin connector, shielded, 24 AWG, 3.3 ft. (1.0m) (High-Speed I/O modules only) | 300V, 80°C | 0.7 | <---> |
| ZL-CBL40-2S | Cable for module with 40-pin connector to 40-pin connector, shielded, 24 AWG, 6.6 ft. (2.0m) (High-Speed I/O modules only) | 300V, 80°C | 1.2 | <---> |
| ZL-P3-CBL40-1P | Cable for module with 40 terminals to pigtail, 24 AWG, 3.3 ft. (1.0m) | 300V, 80°C | 0.41 | <---> |
| ZL-P3-CBL40-2P | Cable for module with 40 terminals to pigtail, 24 AWG, 6.6 ft. (2.0m) | 300V, 80°C | 0.56 | <---> |
| Universal ZIPLink Cables | | | | |
| ZL-CBL24-1P | Cable with 24-pin connector to 24-wire pigtail for connecting any 24-pin ZIPLink module to another device, 24 AWG, 3.3 ft. (1.0m) | 300V, 80°C | 0.36 | <---> |
| ZL-CBL24-2P | Cable with 24-pin connector to 24-wire pigtail for connecting any 24-pin ZIPLink module to another device, 24 AWG, 6.6 ft. (2.0m) | 300V, 80°C | 0.56 | <---> |
| ZL-DB9F-CBL-2P | ZIPLink pigtail cable with 9-pin D-sub female connector, 28 AWG, 2.0 meter (6.6 ft) length | 300V, 80°C | 0.30 | <---> |
| ZL-DB9F-CBL-5P | ZIPLink pigtail cable with 9-pin D-sub female connector, 28 AWG, 5.0 meter (16.4 ft) length | 300V, 80°C | 0.30 | <---> |
| ZL-CBL40-1P | Cable that allows the ZL-RTB40, ZL-RFU40 or ZL-LTB32-24 to custom wire to third party devices, 24 AWG, 3.3 ft. (1.0m) | 300V, 80°C | 0.41 | <---> |
| ZL-CBL40-2P | Cable that allows the ZL-RTB40, ZL-RFU40 or ZL-LTB32-24 to custom wire to third party devices, 24 AWG, 6.6 ft. (2.0m) | 300V, 80°C | 0.56 | <---> |
| Serial Communication ZIPLink Cables | | | | |
| ZL-DB9-CBL-2 | Shielded cable with 9-pin D-sub male to female connectors, 28 AWG, 6.6 ft. (2.0m) | 300V, 80°C | 0.36 | <---> |
| ZL-DB15-CBL-2 | Shielded cable with 15-pin D-sub male to female connectors, 28 AWG, 6.6 ft. (2.0m) | 300V, 80°C | 0.56 | <---> |
| ZL-DB25-CBL-2 | Shielded cable with 25-pin D-sub male to female connectors, 28 AWG, 6.6 ft. (2.0m) | 300V, 80°C | 0.56 | <---> |
| ZL-RJ12-CBL-2 | Crossover cable with 6-pin RJ12 to 6-pin RJ12 connectors, 26 AWG, 6.6 ft. (2.0m) | 150V, 60°C | 0.26 | <---> |
| ZL-RJ12-CBL-2P | Cable with 6-pin RJ12 connector to 6-wire pigtail, 26 AWG, 6.6 ft. (2.0m) | 150V, 60°C | 0.26 | <---> |



ZL-P3-CBL20-1



ZL-CBL24-1P



ZL-DB9-CBL-2



ZL-RJ12-CBL-2



ZL-DB9F-CBL-2P



ZL-RJ12-CBL-2P

| ZIPLink Connection Cables | | | | | |
|--|---|-------------------|--------------|-------|--|
| Part Number | Description | Insulation Rating | Weight (lbs) | Price | |
| AC Drive, Servo, Stepper, and Soft Starter ZIPLink Cables | | | | | |
| GS-RJ12-CBL-2 | RS232 cable with 6-pin RJ12 connector to 6-pin RJ12 connector for GS2 Series drives ONLY. 26 AWG, 6.6 ft. (2.0m) | 300V, 80°C | 0.26 | <---> | |
| GS-485HD15-CBL-2 | RS485 shielded twisted pair cable with 6-pin RJ12 to HD 15-pin male connector for all GS Series/DuraPulse drives, 28 AWG, 6.6 ft. (2.0m) | 30V, 80°C | 0.26 | <---> | |
| GS-485RJ12-CBL-2 | GS drive communication cable with 6-pin RJ12 connector to 6-pin RJ12 connector, 3-wire straight-through, 26 AWG, 6.6 ft. (2.0m). Use this cable and a ZL-CDM-RJ12Xxx distribution module to create a plug and play RS-485 network. Connect multiple SureServo amplifiers, Stellar SR44 soft starters, GS series drives, and Durapulse series drives to a PLC via RS-485. | 300V, 80°C | 0.11 | <---> | |
| GS-EDRV-CBL-2 | GS drive communication cable with 6-pin RJ12 connector to 6-pin RJ12 connector, 6-wire straight-through, 26 AWG, 6.6 ft. (2.0m). Use this cable to connect GS series and Durapulse series drives to the GS-EDRV ethernet communication module. | 150V, 60°C | 0.11 | <---> | |
| GS-ISOCAN-CBL-2 | GS drive communication cable with 6-pin RJ12 connector to the FA-ISOCAN 5-pin connector, 26 AWG, 6.6 ft. (2.0m). Use this cable to connect GS series and Durapulse series drives to the FA-ISOCAN universal serial communications converter. | 150V, 60°C | 0.11 | <---> | |
| ZL-SVC-CBL50 | Shielded twisted pair cable with 50-pin connectors to connect any SureServo amplifier to a ZL-RTB50 module, 28 AWG, 1.6 ft. (0.5m) | 30V, 80°C | 0.36 | <---> | |
| ZL-SVC-CBL50-1 | Shielded twisted pair cable with 50-pin connectors to connect any SureServo amplifier to a ZL-RTB50 module, 28 AWG, 3.3 ft. (1.0m) | 30V, 80°C | 0.46 | <---> | |
| ZL-SVC-CBL50-2 | Shielded twisted pair cable with 50-pin connectors to connect any SureServo amplifier to a ZL-RTB50 module, 28 AWG, 6.6 ft. (2.0m) | 30V, 80°C | 0.56 | <---> | |
| ZL-CBL50-1P | SureServo cable used to connect any SureServo amplifier to custom wire to third party devices, 28AWG, 3.3 ft. (1.0m) | 30V, 80°C | 0.46 | <---> | |
| ZL-CBL50-2P | SureServo cable used to connect any SureServo amplifier to custom wire to third party devices, 28AWG, 6.6 ft. (2.0m) | 30V, 80°C | 0.56 | <---> | |
| SVC-232RJ12-CBL-2 | RS232 shielded twisted pair cable with 6-pin RJ12 to 6-pin IEEE connector for all SureServo amplifiers, 6.6 ft. (2.0m) | 30V, 80°C | 0.16 | <---> | |
| SVC-485HD15-CBL-2 | RS485 shielded twisted pair cable with HD 15-pin male to 6-pin IEEE connector for all SureServo amplifiers, 6.6 ft. (2.0m) | 30V, 80°C | 0.26 | <---> | |
| SVC-485RJ12-CBL-2 | SureServo amplifier communication cable with a RJ12 male to a 6-pin IEEE connector, shielded, twisted pair, 6.6 ft. (2.0m). Use this cable and a ZL-CDM-RJ12Xxx distribution module to create a plug and play RS-485 network. Connect multiple SureServo amplifiers, Stellar SR44 soft starters, GS series drives, and Durapulse series drives to a PLC via RS-485. | 30V, 80°C | 0.16 | <---> | |
| SVC-485CFG-CBL-2 | SureServo amplifier configuration cable with 6-pin IEEE connector to RJ45 connector, shielded, twisted pair, 6.6 ft. (2.0m). Use this cable in conjunction with the USB-485M serial adapter to connect any SureServo amplifier to a PC. Eliminates the need to reprogram networked servo drives from RS485 to RS232 when connecting to a PC. | 30V, 80°C | 0.16 | <---> | |
| STP-232RJ12-CBL-2 | SureStep drive communication cable with 6P4C RJ11 connector to 6-pin RJ12 connector, 3-wire, RS-232, 26 AWG, 6.6 ft. (2.0m). Use this cable to connect STP-DRV-4850 or STP-DRV-80100 stepper drives to a DL05 PLC or a CLICK PLC. | 300V, 80°C | 0.11 | <---> | |
| STP-232HD15-CBL-2 | SureStep drive communication cable with 6P4C RJ11 connector to 15-pin high density connector, 3-wire, RS-232, 26 AWG, 6.6 ft. (2.0m). Use this cable to connect STP-DRV-4850 or STP-DRV-80100 stepper drives to a DL06 PLC or a DL205 PLC using a D2-250-1 or D2-260 CPU. | 30V, 80°C | 0.21 | <---> | |
| SR44-485HD15-CBL-2 | Stellar soft starter communication cable with 6-pin RJ45 connector to 15-pin high density connector, 3-wire, RS-485, 26 AWG, 6.6ft. (2.0m). Use this cable to connect a Stellar SR44 series soft starter (with optional SR44-RS485 communication adapter) to a DL06 PLC or a DL205 PLC using a D2-250-1 or D2-260 CPU. | 30V, 80°C | 0.21 | <---> | |
| SR44-485RJ45-CBL-2 | Stellar SR44 soft starter communication cable with 6-pin RJ45 connector to 6-pin RJ12 connector, 3-wire, RS-485, 26 AWG, 6.6 ft. (2.0m). Use this cable and a ZL-CDM-RJ12Xxx distribution module to create a plug and play RS-485 network. Connect multiple SureServo amplifiers, Stellar SR44 soft starters (with optional SR44-RS485 communication adapter), GS series drives, and Durapulse series drives to a PLC via RS-485. | 30V, 80°C | 0.16 | <---> | |



GS-485HD15-CBL-2



SVC-232RJ12-CBL-2



SVC-485HD15-CBL-2



ZL-SVC-CBL50



ZL-CBL50-1P



If it's in your cabinet, it's in our catalog! Over 13,000 In-stock Quality Products

Starting with the enclosure, we carry everything you need to build an electrical control system, right down to the wire and tools. And we have the devices that go in the panel, such as logic controllers, HMI, drives, relays, and motor controls. If you're maintaining existing systems, we've got great prices on MRO parts such as circuit breakers, fuses, motors, pneumatics and pilot devices. In addition to our catalog all our products are available to **order 24/7 at www.automationdirect.com**

Value Pricing

Our everyday prices on industrial control products are well below the list prices of more traditional automation companies because, with our direct business model and focus on high efficiency, AUTOMATIONDIRECT has the **lowest overhead in the industry**. We pass the savings on to you by offering high-quality products at low prices.

FREE Award Winning Support

Almost 99% of AUTOMATIONDIRECT customers responding to surveys say they would recommend us to someone else, and they do! And we've been **voted tops in service by independent magazine surveys nine years running**.

FREE & Fast Shipping*

The majority of our products are stocked for same-day shipping, when you place your order by 6 p.m. EST.

* Same day shipping with approved company credit or credit card. Free 2-day (transit) shipping for orders over \$49; other expedited services extra. See Web site or catalog Terms and Conditions for all details and exceptions.

ZIPport Multi-Wire Connectors 3 to 144 Terminals



Standard and High Construction Profile (HC) Heavy Duty Connectors

Customize your own cable connectors to suit your specific needs while reducing machine installation time and costs

Multi-wire connectors are heavy-duty connectors that will hold up under harsh indoor and outdoor industrial environments. They have the versatility to maintain and protect the different types of electrical connections that are popular within industry today.

ZIPport multi-wire connectors range from a small 3-pin configuration to as large as 144-pin configuration. Screw terminal connection available up to 40-pins and crimp contact connectors are available from 5-pin to 144-pin.

ZIPport connectors can be used anywhere there is a need to have the ability to reliably connect and/or disconnect wiring. These types of connectors are found in many industries such as:

- Electronic machinery
- Robots
- Control equipment
- Power connections
- Control and signal circuits
- Packaging machinery
- Theatrical applications
- Industrial equipment
- Electrical panels

Agency Approvals

- UL Recognized File number E 342543
- CE
- RoHS
- NEMA/UL type 1, 4, 4X, 12

Save time and money

- Eliminate repetitive wiring tasks
- Cut down installation time
- Save on downtime for machine setup
- Increase quality by making your own pre-wired cable/connection wire
- Reduce costly equipment repairs and troubleshooting time



Features

- Available in 3A, 10A, 16A, 10B, 16B, 24B, and 32B sizes
- Heavy-duty metal housings in polyester powder coated die-cast aluminum alloy or self-extinguishing thermoplastic housing
- Single locking system (one lever locked on two pegs) or double locking system (two levers locked on four pegs)
- Mechanical duration of 500 cycles
- Operating temperatures from -40°C to 125°C (-40°F to 257°F)
- IP66 degree of protection with enclosure when coupled
- NEMA/UL Type 1, 4, 4X, 12 protection when housings are coupled.
- Conforms with EN61984, VDE 0110, VDE 0627, EN 175301-801, and UL 1977, UL50, UL50E standards
- UL and CE approvals

Heavy-duty multi-wire connectors are used wherever there is a need for a secure, simple and time-saving assembly of machinery and facilities. The connector housings are made of die-cast aluminum or thermoplastic and offer excellent protection against dirt, moisture and mechanical stress. Multi-wire connectors make it possible to easily connect signal, power, and data connections.



120VAC Power or Control (10-Pole, Size 10B)

| | | | |
|------------------------|--------|----------------------|---------|
| • 1) ZP-MC10B-1-MS010 | \$5.50 | • 1) ZP-MC10B-2-SBHM | \$27.50 |
| • 1) ZP-MC10B-1-FS010 | \$5.50 | • 1) ZP-MC-CG-16M8 | \$3.85 |
| • 1) ZP-MC10B-2-SSE16M | \$8.25 | | |

(only sold in pack of 10 for \$38.50)

Total: \$50.60



24VDC Signal or Control (16-pole, Size 16B)

| | | | |
|-------------------------|---------|-------------------------|---------|
| • 1) ZP-MC16B-1-FS016 | \$7.75 | • 1) ZP-MC16B-2-DCP21ML | \$28.00 |
| • 1) ZP-MC16B-1-MS016 | \$7.75 | • 2) ZP-MC-CG-21M8 | \$12.20 |
| • 1) ZP-MC16B-2-DTE21ML | \$12.50 | | |

(only sold in pack of 5 for \$30.50)

Total: \$68.20



Power or Control (3-pole, Size 3A)

| | | | |
|------------------------|--------|----------------------|--------|
| • 1) ZP-MC03A-1-MS004 | \$2.25 | • 1) ZP-MC03A-2-SBHP | \$1.00 |
| • 1) ZP-MC03A-1-FS004 | \$2.75 | • 1) ZP-MC-CG-11P5 | \$1.00 |
| • 1) ZP-MC03A-2-STE11P | \$0.50 | | |

Total: \$7.50

Connector Housings

- The housings for these ZIPport industrial multi-wire connectors consist of a hood that mates with a base or a coupler.
- Multiwire connector housings are made of die-cast aluminum with a polyester powder finish or from self-extinguishing thermoplastic and are suitable for use in industrial applications.
- All multi-pole connector housings are available in a standard profile. Several models of these heavy duty connectors are offered with a high construction (HC) profile that allows more room for wiring the higher density inserts.
- A single or double lever locking system assures coupling stability and protection against accidental opening. The wire connector locking system is comprised of stainless steel or glass filled thermoplastic levers, with compatible interlocking pegs.

Connector Inserts

- ZIPport multi-wire connectors require one male and one female insert. The inserts are available in multiple pole configurations from 3 poles plus ground, up to 108 poles plus ground, and with termination sizes ranging from 14 to 5 AWG, 10 to 80 Amps.
- ZIPport inserts are made of UL 94 V-0 rated self-extinguishing thermoplastic resin rated at a maximum temperature of 125°C (257°F).
- The inserts are available in screw terminal or crimp style contact block connections. The contacts are copper alloy with a hard silver or gold plating. The plastic inserts for these rectangular connectors are numbered on both sides by laser printing or molding in accordance with EN 60068-2-70.



STD Series Multi-Wire Connectors

Features

- Available in 3A, 10A, 16A, 6B, 10B, 16B, 24B, and 32B sizes
- Heavy-duty metal housings in polyester powder coated die-cast aluminum alloy or self-extinguishing thermoplastic housing
- Single locking system (one lever locked on two pegs) or double locking system (two levers locked on four pegs)
- Mechanical duration of 500 cycles
- Operating temperatures from -40°C to 125°C (-40°F to 257°F)
- IP66 degree of protection with enclosure when coupled
- NEMA/UL Type 1, 4, 4X, 12 protection with enclosure when coupled.
- Conforms with EN61984, VDE 0110, VDE 0627, EN 175301-801, and UL 1977, UL50, UL50E standards
- UL and CE approvals

Housings

Hoods

- Available with top entry and side entry cable passages
- Standard and high-construction profiles
- Threaded cable passages with Pg threads (EN 60423) with optional Pg to NPT adapters
- Stainless steel or thermoplastic locking pegs
- Accessories include cable glands and Pg thread to NPT adapters

Bases, Couplers and Covers

- Surface and bulkhead mounted bases
- Two cable passages on surface mount bases
- Seal gaskets made of anti-aging, oil-resistant and fuel-resistant vinyl nitrile elastomer
- Locking levers made of galvanized steel or self-extinguishing glass-filled thermoplastic; guarantees perfect closing and sealing

Inserts

- Self-extinguishing thermoplastic reinforced with glass fibers
- Asymmetric guide rails prevent incorrect coupling
- Captive installation screws allow for easy and secure installation to bases and hoods
- Laser-printed or molded terminal/contact positions on both sides of insert
- Copper alloy contacts with hard silver or gold plating - available with stainless steel captive screw terminal or machined crimp contact
- Wide contact surface for ground terminals
- IP20 without enclosures
- Suitable for stranded and solid conductors

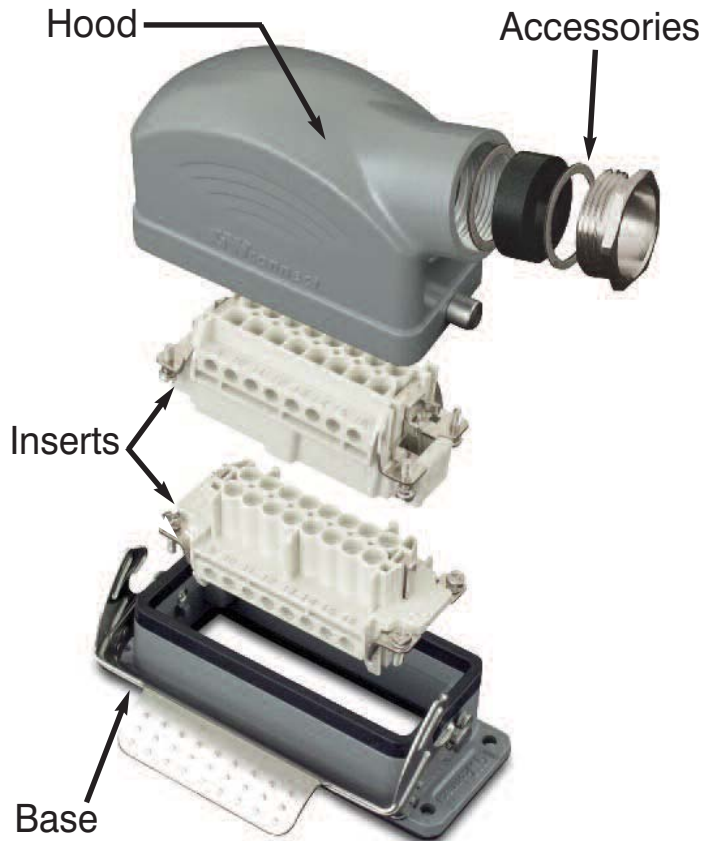

Accessories

- A wide range of accessories including:
 - Pg to NPT adapters
 - Plugs with gaskets
 - Cable glands (IP66 & IP68)
 - DIN rail mounting kits
 - Crimp tools
 - Replacement screws, code pins and gaskets
 - Insert plates (with cutouts, reducers, blank)
 - Coding pins

Agency Approvals

- UL Recognized File number E342543
- CE
- RoHS
- NEMA 250





STD Series Multi-Wire Connectors

General Characteristics

Application Examples

- Electronic machinery
- Robots
- Control equipment
- Power connections
- Control and signal circuits
- Packaging machinery
- Theatrical applications
- Industrial equipment
- Electrical panels

Inserts

ZIPport multi-wire connectors require one male and one female insert. The inserts are available in multiple pole configurations from 3 poles plus ground up to 144 poles plus ground and with termination sizes ranging from 26 to 12 AWG, 10 to 80 Amps.

ZIPport inserts are made of UL 94 V-0 rated self-extinguishing thermoplastic resin rated at a maximum temperature of 125°C (257°F). The inserts are available in screw terminal and crimp style contact block connections. The contacts are copper alloy with a hard silver or gold plating. The plastic insulators are numbered on both sides by laser printing or molding in accordance with EN 60068-2-70.

- Suitable for use with alternating (AC) or direct current (DC)
- Leading protective ground
- Polarized for correct mating
- Interchangeable for male and female inserts in hoods and bases
- Captive screws
- Can be used with hoods and bases, or with rack and panel applications

Housings

The housings for the ZIPport multi-wire connectors consist of a hood that mates with a base or a coupler.

They are made of die-cast aluminum with a polyester powder finish or from self-extinguishing thermoplastic and are suitable for use in industrial applications.

All housings are available in a standard profile. Several are offered with a high construction (HC) profile that allows more room for wiring the higher density inserts.

A single or double lever locking system assures coupling stability and protection against accidental opening. The locking system is comprised of stainless steel or glass filled thermoplastic levers, with compatible interlocking pegs.

Size and Identification

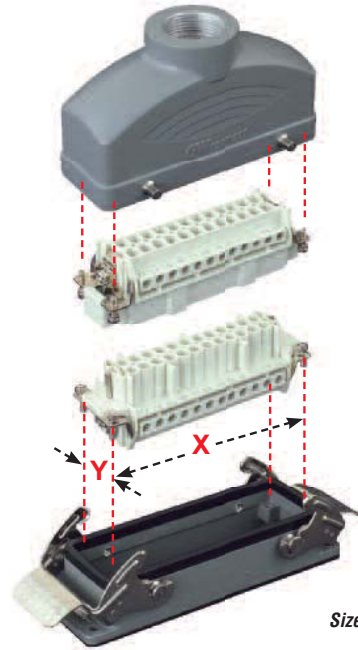

Size 24B shown

The size of each type of connector is determined by the distance between the center points of the four installation screws. These four points are common to both the insert and the housing. This is indicated by "X"- "Y" in the illustration above.

The table below lists the size identification and the actual X-Y distance for each type of connector offered.

| Size | Distance X-Y |
|------------|-------------------------------|
| 3A | 21 x 21 mm* [0.83 x 0.83 in] |
| 10A | 49.5 x 16 mm [1.95 x 0.63 in] |
| 16A | 66 x 16 mm [2.60 x 0.63 in] |
| 6B | 44 x 27 mm [1.73 x 1.06 in] |
| 10B | 57 x 27 mm [2.24 x 1.06 in] |
| 16B | 77.5 x 27 mm [3.05 x 1.06 in] |
| 24B | 104 x 27 mm [4.09 x 1.06 in] |
| 32B | 77.5 x 62 mm [3.05 x 2.44 in] |

** The center distance cannot be given because the 3A inserts have only one screw: 21 x 21 indicates the size of the sectioned insert.*

Conductor Termination

Overview

Two types of conductor termination are available for ZIPport inserts:

- Screw terminations
- Crimp terminations

Screw Terminations

Screw terminations consist of contacts made of silver-plated copper alloy and are incorporated with a wire clamp (with the exception of the size 3A inserts and size 24B with 80A contacts) for firmly securing the conductors. The screw terminals use stainless steel captive screws and meet VDE 0609 / EN 60999 standards.

Proper conductor installation requires no special preparation when using inserts with the wire clamp terminals (no wire ferrules). The table below lists the current rating, maximum wire gauge and stripping lengths.

| Current Rating | Max Wire Gauge | | Stripping Length mm (in) |
|----------------|-----------------|------|-----------------------------|
| | mm ² | AWG | |
| 10A | 2.5 | 14 | 4.5 (0.18) |
| 16A | 2.5 | 14 | 7 (0.28) |
| 35A | 6.0 | 10 | 11.5 (0.45) |
| 16/80A | 25/16 | 14/5 | 7 (0.28)/14 (0.55) |

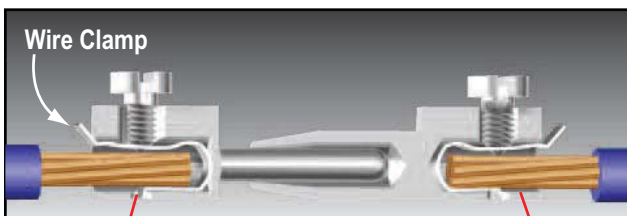

Screw Terminals with Wire Clamps

The value of tensile strength of conductors in accordance with the dimensions of the screws and the wires are shown in the following table:

| Wire Gauge mm ² (AWG) | 1.5 (16) | 2.5 (14) | 4 (12) | 6 (10) | 10 (8) | 16 (6) |
|--|-------------|-------------|-----------|-----------|-----------|-----------|
| Size of Screw | M3 | M3 | M3.5 | M4 | M4 | M6 |
| Tensile Strength of Stranded Wire (N) | 40 | 50 | 60 | 80 | 90 | 100 |

Increasing the tightening torque does not necessarily improve the contact resistance. The screw torques are selected according to standard EN 60999-1, to provide excellent mechanical, thermal and electrical behaviour. The conductor or terminal may be damaged if the recommended values are significantly exceeded.

| Insert Screw Specifications | | | | | | |
|-----------------------------|-----------------|------------|---------------------------|-------------------------------|---------------------------------|---------------------------------|
| Insert Size | Screw Type | Screw Size | Tightening Torque (Nm) | Tightening Torque (in-lbs) | Recommended Screwdriver Size | Recommended Screwdriver Part |
| 3A | 10 Amp Terminal | M3 | 0.25 | 2.2 | 0.4 x 2.5 | DN-SS3 |
| | Installation | M3 | | | | |
| | Ground | M3.5 | | | | |
| 10A, 16A | 16 Amp Terminal | M3 | 0.50 | 4.4 | 0.5 x 3.0 | TW-SD-SL-1 |
| | Installation | M3 | | | | |
| | Ground | M4 | | | | |
| 6B, 10B | 16 Amp Terminal | M3 | 0.50 | 4.4 | Ph 0-0.8 x 4 | DN-SS4 |
| | Installation | M3 | | | | |
| | Ground | M4 | | | | |
| 16B | 35 Amp Terminal | M4 | 1.2 | 10.6 | Ph 1 - 0.8 x 4 | DN-SS4 |
| | 16 Amp Terminal | M3 | 0.50 | 4.4 | Ph 0-0.8 x 4 | |
| | Installation | M3 | 0.50 | 4.4 | Ph 0-0.8 x 4 | |
| | Ground | M4 | 1.2 | 10.6 | Ph 2 1.0 x 5.5 | DN-SS5 |
| | Ground | M4 | 1.2 | 10.6 | Ph 2 1.0 x 5.5 | DN-SS5 |
| 24B | 80 Amp Terminal | M6 | 2.5 | 22.1 | 1.0 x 5.5 | DN-SS4 |
| | 16 Amp Terminal | M3 | 0.50 | 4.4 | Ph 0-0.8 x 4 | |
| | Installation | M3 | 0.50 | 4.4 | Ph 0-0.8 x 4 | |
| 32B* | Ground | M4 | 1.2 | 10.6 | Ph 2 1.0 x 5.5 | DN-SS5 |
| | 16 Amp Terminal | M3 | 0.50 | 4.4 | Ph 0-0.8 x 4 | DN-SS4 |
| | Installation | M3 | 0.50 | 4.4 | Ph 0-0.8 x 4 | |
| Ground | M4 | 1.2 | 10.6 | Ph 2 1.0 x 5.5 | DN-SS5 | |

*Note: Size 32B requires 2 size 16B inserts

Crimp Terminations

Crimp terminations consist of contacts made of silver or gold-plated copper alloy. Crimp terminations are accomplished by applying a crimp contact to the conductor by means of a crimping tool. Crimp contacts are available in several sizes:

- 10 amp, 26-14 AWG
- 16 amp, 26-12 AWG

A perfect crimp connection is gastight, corrosion free and is equal to a cold weld of the parts being connected. Wires to be connected must be carefully matched with the correct wire size of crimp contacts.

The requirements for crimp connectors are depicted in IEC 60352, part 2.

Note: Low currents and voltages:

ZIPport standard contacts (screw and crimp) have a silver plated surface. This metal has excellent conductive properties. During the contacts's lifetime, the silver surface generates a black oxide layer due to its affinity to sulphur (always present in the atmosphere). This layer is conductive smooth and very thin and is partly interrupted when the contacts are mated and unmated, thus guaranteeing very low contact resistances. In the case of very low current or voltage, small changes to the transmitted signal may be encountered.

In applications where voltage and current are lower than 5V and 5mA, and in extremely aggressive environments, ZIPport gold plated contacts are recommended. See ZIPport spare parts and accessories pages.



STD Series Multi-Wire Connectors

Crimp Contact to Insert Installation

Proper installation of the crimp contacts is important for a good electrical and mechanical connection. The following steps will ensure correct installation.

Step 1: Select the Crimp Contacts

Select a crimp contact based on the rating of the Insert you are using - 10 or 16 amps; the gender - male or female; and gauge of wire being used.

Step 2:

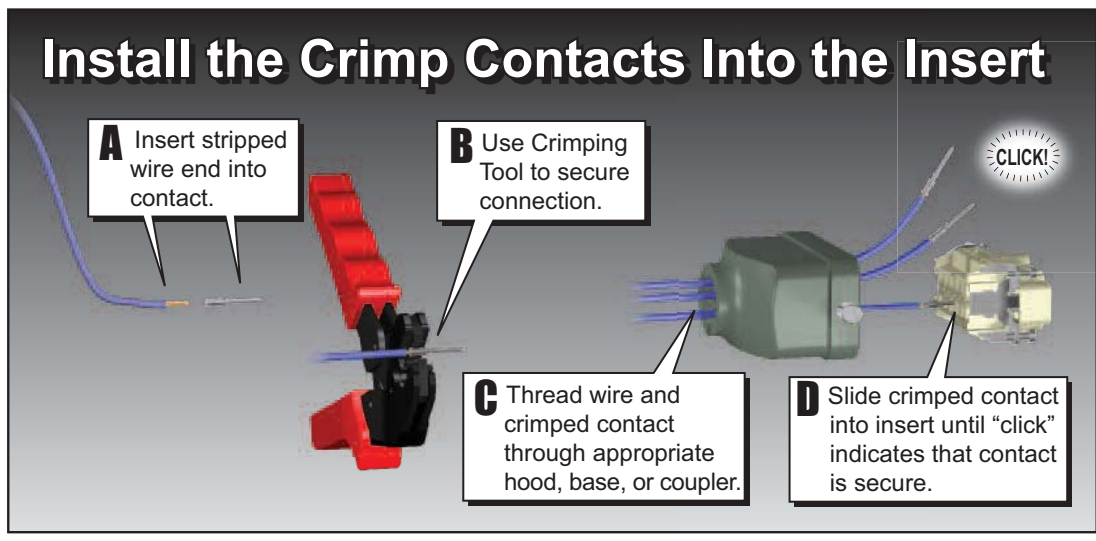

Step 3: Install the Insert into the Housing.

Now that the crimp contacts are installed, the insert can be placed into the housing by aligning the corner installation screws of the insert with the screw holes located in the corners of the housing. Tighten the screws according to the tightening torques listed in the Insert Screw Specifications table in this document.

Wire Entry Connection

ZIPports offer four types of connection for wire entry into the housings. Two entries accommodate flex conduit and two accept cable.

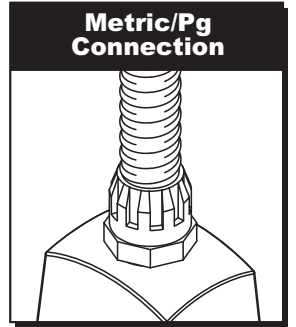

This is standard on all housings that offer a threaded wire entry. Sizes range from Pg 11 to Pg 36. This is for using fittings with a male Pg thread connection.

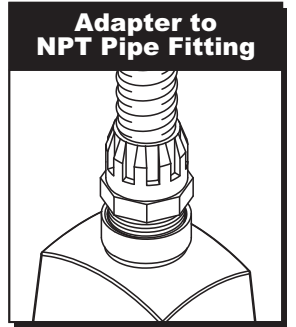

This adapter converts the Pg thread to an NPT thread. Sizes range from 3/8" to 1-1/4" in relation to the Pg threaded opening in the housing.

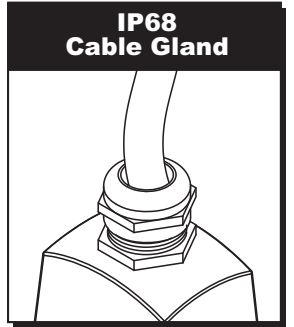

For securing a cable to the housing. This is an all inclusive fitting that can be tightened without using separate washers.

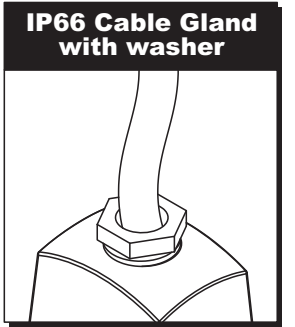

For securing a cable to the housing. This gland is available in plastic or metal in relation to housing material. Includes two washers and four gaskets to accommodate a wide range of cable diameters.



Standards

The inserts are designed and manufactured to conform with EN 61984, (IEC 61984), VDE 0627 and UL 1977/CSA C22.2 182.3 standards. They are certified and labeled with the cULus and CE marks. The connectors are therefore in conformance with both European/International and American systems. This permits them to be used in a wider range of applications worldwide.

| | |
|--|--|
| • EN 61984 | Connectors safety requirements and tests |
| • VDE 0627 | Connectors (DIN VDE 0627) |
| • EN 60664-1 | Insulation coordination for equipment within low-voltage systems |
| • EN 175 301-801 | High density rectangular connectors, round removable crimp contacts |
| • EN 60947-7-1 part 7-1 | Low-voltage switchgear and control gear, Ancillary equipment - Terminal blocks for copper conductors |
| • VDE 0110 | Table 4 concerning clearance and creepage distances |
| • EN 60512 | Connectors for electronic equipment, tests and measurements |
| • UL 1977 | Component connectors for use in data, signal, control and power applications |
| • CSA.C22.2 No. 182.3 | Special use attachment, plugs, receptacles and connectors |
| • EN 60529 | Degree of protection provided by enclosures (IP degree) |
| • EN 50262 | Metric cable glands for electrical installation |
| • EN 60423 | Conduits for electrical purposes. Outside diameters of conduits for electrical installations and thread for conduits and fittings |
| • ISO 23570-2 | Industrial automation system and integration. Distributed installation in industrial applications. Part 2: Hybrid communication bus. |
| • ISO 23570-3 | Industrial automation system and integration. Distributed installation in industrial applications Part 3: Power distribution bus. |
| DESINA® specifications (Distributed and Standardized Installation Technology), Studied by German Manufacturers of Machine Tool Association. | Specification to standardize electrical, hydraulic and pneumatic components and their interconnection on a common platform for CNC controlled machine tools and manufacturing lines. |

Directives and Declarations

NEMA-250 Declaration of Conformity

Metal and plastic enclosures for Multipole Industrial Connectors (Heavy Duty Connectors). Series STD, STD-HV, HE, HE-HV all sizes. Are designed and manufactured in conformity with NEMA 250-1991 Standard and meet the requirements of NEMA Type 4, 4x and 12.

2006/95/EC: LVD Directive

Directive 2006/95/EC of the European Parliament and of the council of 12 December 2006 on the harmonisation of the laws of Members States relating to electrical equipment designed for use within certain voltage limits.

2002/95/EC: RoHS Directive

Directive 2002/95/EC of the European Parliament and of the Council of 27 January 2003 on the restriction of the use of certain hazardous substances in electrical and electronic equipment.

2008/35/EC: RoHS Directive amendment

Directive 2008/35/EC of the European Parliament and of the Council of 11 March 2008 amending Directive 2002/95/EC of the use of certain hazardous substances in electrical and electronic equipments (RoHS) as regards the implementing powers conferred on the Commission.

2004/108/EC EMC Directive

EMC, Electromagnetic Compatibility Directive.

In accordance with the European Directive that regulates the emission and the immunity of the equipment, for the products designed for EMC industrial applications.

Regulation (EC) No 1907/2006 of the European Parliament and of the Council of 18 December 2006 concerning the Registration Evaluation, Authorization and Restriction of Chemicals (REACH), establishing a European Chemicals Agency, amending Directive 1999/45/EC and repealing Council Regulation (EEC) No 793/93 and Commission Regulation (EC) No 1488/94 as well as Council Directive 76/769/EEC and Commission Directives 91/155/EEC, 93/67/EEC, 93/105/EEC and 2000/21/EC.



Warning - According to EN 61984, connectors should not be coupled and decoupled under electrical load.

Crimp Contact Basic Assembly

Screw Terminal Basic Assembly

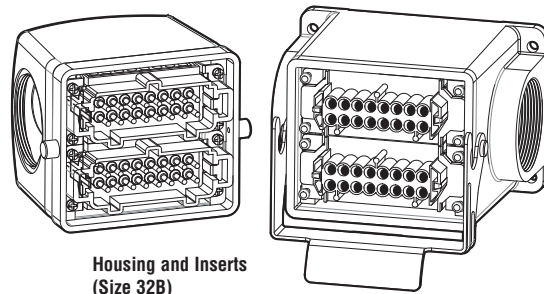
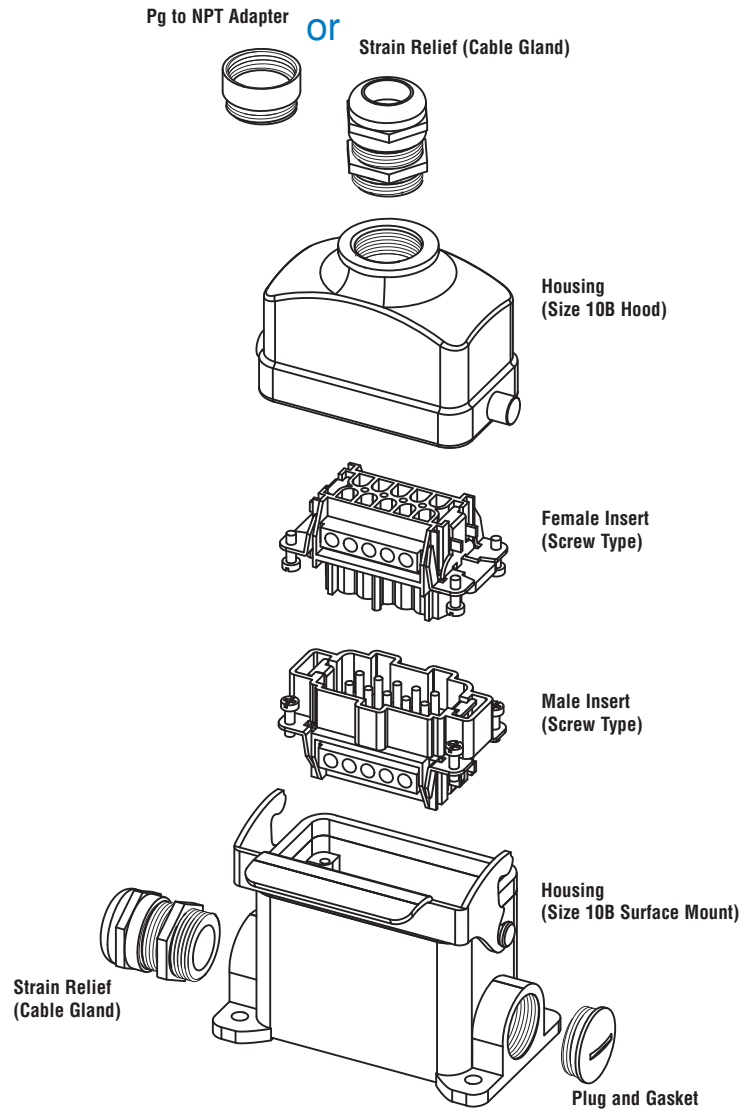
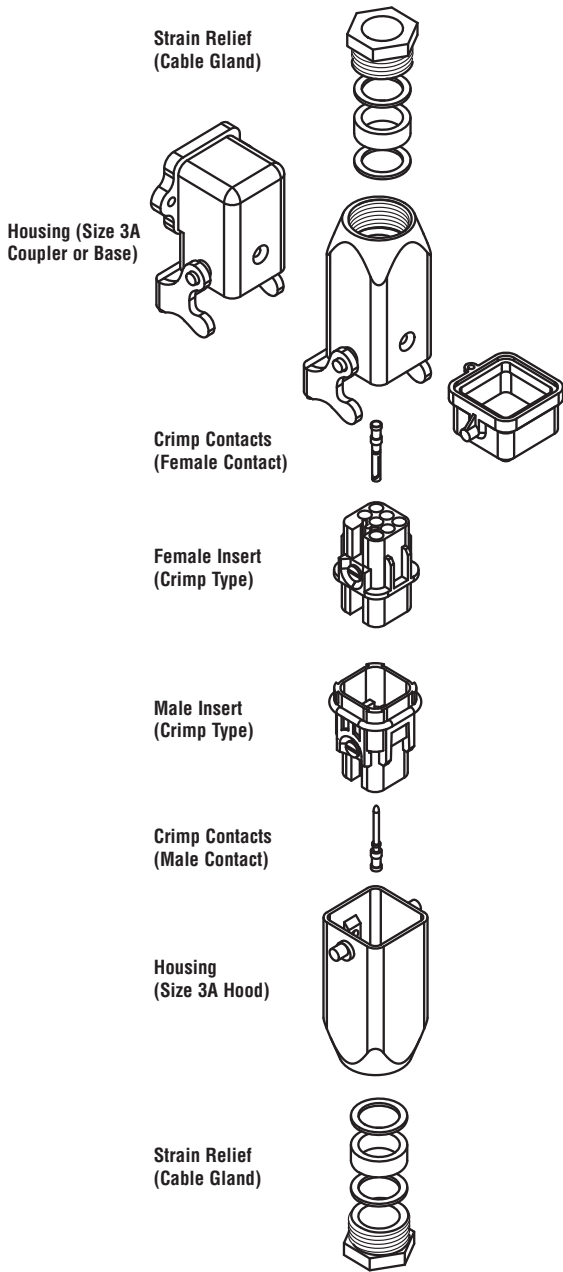

Housing and Inserts (Size 32B)



STD Series Multi-Wire Connectors Specifications

| Technical Characteristics | | | | | | | | | | | |
|--|---|---|-----------------------------------|-------------------------|--------------------------|--------------------------|--------------------------|--------------------------|--------------------------|--------------------------|--------------------------|
| Connector Size | | 3A | | | | | 10A | | 16A | | |
| Inserts | Number of Poles | 3+PE | 4+PE | 5+PE | 7+PE | 12+PE | 10+PE | 15+PE | 16+PE | 25+PE | |
| | UL/CSA Rated Voltage* | 600V | | | | | | | | | |
| | Maximum Rated Current | 10A | 16A | 10A | | | 16A | 10A | 16A | 10A | |
| | EN 61984 (2001-11) Pollution Degree 3 | Rated Voltage AC/DC | 230/400V | | | 250V | 400V | 250V | | | |
| | | Impulse Withstand Voltage | 4kV | | | | 6kV | | 4kV | | |
| | EN 61984 (2001-11) Pollution Degree 2 | Rated Voltage | 230/400V | 320/500V | 230/400V | 400/690V | 230/400V | | | | |
| | | Impulse Withstand Voltage | 4kV | | | | 6kV | | 4kV | | |
| | Continuous Current Carrying Capacity | Refer to Electrical Engineering section charts | | | | | | | | | |
| | Insulation Resistance | 10 ¹⁰ Ω | | | | | | | | | |
| | Material | Polycarbonate | | | | | | | | | |
| | Temperature Range | -40°C to 125°C (-40°F to 257°F) | | | | | | | | | |
| | Flammability | UL 94 V-0 GWT 960° | | | | | | | | | |
| | Degree Protection | With Housing | IP66, NEMA/UL (Type 1, 4, 4x, 12) | | | | | | | | |
| | | Without Housing | IP20 | | | | | | | | |
| | Mechanical Working Life | 500 Cycles | | | | | | | | | |
| Conductor Termination | Screw Terminals | ✓ | ✓ | N/A | N/A | N/A | ✓ | N/A | ✓ | N/A | |
| | Crimp Contacts | N/A | N/A | ✓ | ✓ | ✓ | ✓ | ✓ | ✓ | ✓ | |
| Contacts | Material | Hard-silver plated (2µm Au) or gold plated copper alloy | | | | | | | | | |
| | Min. Recommended Load (voltage & current) | 5V/5mA AC/DC (silver plated) | | | | | | | | | |
| | Contact Resistance | ≤1 mΩ | | | ≤3 mΩ | | | ≤1 mΩ | ≤3 mΩ | ≤1 mΩ | ≤3 mΩ |
| | Screw Terminal Wire Size | mm ² | 0.5-2.5 mm ² | | N/A | | | 0.5-2.5 mm ² | N/A | 0.5-2.5 mm ² | N/A |
| | | AWG | 20-14 AWG | | N/A | | | 20-14 AWG | N/A | 20-14 AWG | N/A |
| | Screw Terminal Tightening Test Torque | 0.5 Nm | | | N/A | | | 0.5 Nm | N/A | 0.5 Nm | N/A |
| | Screw Terminal Stripping Length | 7.0 mm | | | N/A | | | 7.0 mm | N/A | 7.0 mm | N/A |
| | Crimp Terminal Wire Size | mm ² | N/A | 0.5-2.5 mm ² | 0.14-2.5 mm ² | 0.14-4.0 mm ² | 0.14-2.5 mm ² | 0.14-4.0 mm ² | 0.14-2.5 mm ² | 0.14-4.0 mm ² | 0.14-2.5 mm ² |
| | | AWG | N/A | 26-14 AWG | | | 26-12 AWG | 26-14 AWG | 26-12 AWG | 26-14 AWG | 26-12 AWG |
| Crimp Terminal Stripping Length | N/A | 7.5 mm | | N/A | | 7.5 mm | N/A | 7.5 mm | N/A | | |
| Thermoplastic Hoods/Bases/Couplers/Covers | Material | Glass filled polyamide | | | | | N/A | | | | |
| | Locking Element | Glass filled polyamide lever and peg | | | | | | | | | |
| | Flammability | UL 94 V-0 GWT 960° | | | | | | | | | |
| | Housings Seal | NBR (Nitrile rubber) | | | | | | | | | |
| | Degree of Protection Acc. to EN 60529 (coupled) | IP66 | | | | | | | | | |
| | Temperature Range | -40°C to 125°C (-40°F to 257°F) | | | | | | | | | |
| | Thread | Metric EN 50262 Pg DIN 40430 | | | | | | | | | |
| Aluminum Hoods/Bases/Couplers/Covers | Material | Die cast aluminum alloy, Polyester powder coated | | | | | | | | | |
| | Locking Element | Stainless steel lever and peg | | | | | | | | | |
| | Housings Seal | NBR (Nitrile) | | | | | | | | | |
| | Degree of Protection Acc. to EN 60529 (coupled) NEMA 250, UL50, 50E | IP66, NEMA/UL (Type 1, 4, 4x, 12) | | | | | | | | | |
| | Temperature Range | -40°C to 125°C (-40°F to 257°F) | | | | | | | | | |
| | Thread | Metric EN50262 Pg DIN 40430 | | | | | | | | | |

* Connectors should not be coupled and decoupled under electrical load.



STD Series Multi-Wire Connectors Specifications



Company Information

Systems Overview

Programmable Controllers

Field I/O

Software

C-more & other HMI

Drives

Soft Starters

Motors & Gearbox

Steppers/ Servos

Motor Controls

Proximity Sensors

Photo Sensors

Limit Switches

Encoders

Current Sensors

Pressure Sensors

Temperature Sensors

Pushbuttons/ Lights

Process

Relays/ Timers

Comm.

Terminal Blocks & Wiring

Power

Circuit Protection

Enclosures

Tools

Pneumatics

Safety

Appendix

Product Index

Part # Index

| Technical Characteristics | | | | | | | | | | |
|--------------------------------------|---|---------------------------|---|--------------------------|------------------------|--------------------------|-----------------------|-------------------------|--------------------------|-------|
| Connector Size | | 6B | | 10B | | 16B | | | | |
| Inserts | Number of Poles | | 6+PE | 24+PE | 10+PE | 42+PE | 6+PE | 16+PE | 40+PE | 72+PE |
| | UL/CSA Rated Voltage* | | 600V | | | | | | | |
| | Maximum Rated Current | | 16A | 10A | 16A | 10A | 35A | 16A | 10A | |
| | EN 61984 (2001-11) Pollution Degree 3 | Rated Voltage AC/DC | 500V | 250V | 500V | 250V | 830V | 500V | 250V | |
| | | Impulse Withstand Voltage | 6kV | 4kV | 6kV | 4kV | 6kV | | 4kV | |
| | EN 61984 (2001-11) Pollution Degree 2 | Rated Voltage | 400/690V | 230/400V | 400/690V | 230/400V | 1000V | 400/690V | 230/400V | |
| | | Impulse Withstand Voltage | 6kV | 4kV | 6kV | 4kV | 8kV | 6kV | 4kV | |
| | Continuous Current Carrying Capacity | | Refer to Electrical Engineering section charts | | | | | | | |
| | Insulation Resistance | | 10 ¹⁰ Ω | | | | | | | |
| | Material | | Polycarbonate | | | | | | | |
| | Temperature Range | | -40°C to 125°C (-40°F to 257°F) | | | | | | | |
| | Flammability | | UL 94 V-0 GWT 960° | | | | | | | |
| | Degree Protection | With Housing | IP66, NEMA/UL (Type 1, 4, 4X, 12) | | | | | | | |
| | | Without Housing | IP20 | | | | | | | |
| | Mechanical Working Life | | 500 Cycles | | | | | | | |
| Conductor Termination | Screw Terminals | ✓ | N/A | ✓ | N/A | ✓ | ✓ | N/A | N/A | |
| | Crimp Contacts | ✓ | ✓ | ✓ | ✓ | N/A | ✓ | ✓ | ✓ | |
| Contacts | Material | | Hard-silver plated (2µm Au) or gold plated copper alloy | | | | | | | |
| | Minimum Recommended Load (voltage & current) | | 5V/5mA AC/DC (silver plated) | | | | | | | |
| | Contact Resistance | | ≤ 1 mΩ | ≤ 3 mΩ | ≤ 1 mΩ | ≤ 3 mΩ | ≤ 0.5 mΩ | ≤ 1 mΩ | ≤ 3 mΩ | |
| | Screw Terminal Wire Size | mm ² | 0.5-2.5mm ² | N/A | 0.5-2.5mm ² | N/A | 1.5-6 mm ² | 0.5-2.5 mm ² | N/A | |
| | | AWG | 20-14 AWG | N/A | 20-14 AWG | N/A | 16-10 AWG | 20-14 AWG | N/A | |
| | Screw Terminal Tightening Test Torque | | 0.5 Nm | N/A | 0.5 Nm | N/A | 1.2 Nm | 0.5 Nm | N/A | |
| | Screw Terminal Stripping Length | | 7.0 mm | N/A | 7.0 mm | N/A | 10.5 mm | 7.0 mm | N/A | |
| | Crimp Terminal Wire Size | mm ² | 0.14-4 mm ² | 0.14-2.5 mm ² | 0.14-4 mm ² | 0.14-2.5 mm ² | N/A | 0.14-4 mm ² | 0.14-2.5 mm ² | |
| | | AWG | 26-12 AWG | 26-14 AWG | 26-12 AWG | 26-14 AWG | N/A | 26-12 AWG | 26-14 AWG | |
| Crimp Terminal Stripping Length | | 7.5 mm | 8 mm | 7.5 mm | 8 mm | N/A | 7.5 mm | 8 mm | | |
| Aluminum Hoods/Bases/Couplers/Covers | Material | | Die cast aluminum alloy, Polyester powder coated | | | | | | | |
| | Locking Element | | Stainless steel lever and peg | | | | | | | |
| | Housings Seal | | NBR (Nitrile) | | | | | | | |
| | Degree of Protection Acc. to EN 60529 (coupled) NEMA 250, UL50, 50E | | IP66, NEMA/UL (Type 1, 4, 4X, 12) | | | | | | | |
| | Temperature Range | | -40°C to 125°C (-40°F to 257°F) | | | | | | | |
| | Thread | | Metric EN50262 Pg DIN 40430 | | | | | | | |

* Connectors should not be coupled and decoupled under electrical load.



STD Series Multi-Wire Connectors Specifications

| Technical Characteristics | | | | | | | | |
|--------------------------------------|---|---|--|-------------------------|--------------------------|-------------------------|--------------------------|--|
| Connector Size | | 24B | | | | 32B | | |
| Inserts | Number of Poles | 4+8+PE | 24+PE | 64+PE | 108+PE | 32+PE | 144+PE | |
| | UL/CSA Rated Voltage* | 600V | | | | | | |
| | Maximum Rated Current | Power: 80A / Signal: 16A | 16A | 10A | 16A | 10A | | |
| | EN 61984 (2001-11) Pollution Degree 3 | Rated Voltage AC/DC | 830V / 400V | 500V | 250V | 500V | 250V | |
| | | Impulse Withstand Voltage | 8kV / 6kV | 6kV | 4kV | 6kV | 4kV | |
| | EN 61984 (2001-11) Pollution Degree 2 | Rated Voltage | 1000V/400/690V | 400/690V | 230/400V | 400/690V | 230/400V | |
| | | Impulse Withstand Voltage | 8kV | 6kV | 4kV | 6kV | 4kV | |
| | Continuous Current Carrying Capacity | Refer to Electrical Engineering section charts | | | | | | |
| | Insulation Resistance | 10 ¹⁰ Ω | | | | | | |
| | Material | Polycarbonate | | | | | | |
| | Temperature Range | -40°C to 125°C (-40°F to 257°F) | | | | | | |
| | Flammability | UL 94 V-0 GWT 960° | | | | | | |
| | Degree Protection | With Housing | IP66, NEMA/UL (Type 1, 4, 4X, 12) | | | | | |
| | | Without Housing | IP20 | | | | | |
| | Mechanical Working Life | 500 Cycles | | | | | | |
| Conductor Termination | Screw Terminals | ✓ | ✓ | N/A | N/A | ✓ | N/A | |
| | Crimp Contacts | N/A | ✓ | ✓ | ✓ | ✓ | ✓ | |
| Contacts | Material | Hard-silver plated (2µm Au) or gold plated copper alloy | | | | | | |
| | Minimum Recommended Load (voltage & current) | 5V/5mA AC/DC (silver plated) | | | | | | |
| | Contact Resistance | ≤ 0.3 mΩ / 1mΩ | ≤ 1 mΩ | ≤ 3 mΩ | ≤ 1 mΩ | ≤ 3 mΩ | | |
| | Screw Terminal Wire Size | mm ² | 1.5-16 mm ² / 0.5-2.5 mm ² | 0.5-2.5 mm ² | N/A | 0.5-4.0 mm ² | N/A | |
| | | AWG | 16-6 AWG / 20-14 AWG | 20-14 AWG | N/A | 20-12 AWG | N/A | |
| | Screw Terminal Tightening Test Torque | 1.2 Nm / 0.5 Nm | 0.5 Nm | N/A | 0.5 Nm | N/A | | |
| | Screw Terminal Stripping Length | 14 mm / 7.0 mm | 7.0 mm | N/A | 7.0 mm | N/A | | |
| | Crimp Terminal Wire Size | mm ² | N/A | 0.14-4 mm ² | 0.14-2.5 mm ² | 0.14-4 mm ² | 0.14-2.5 mm ² | |
| | | AWG | N/A | 26-12 AWG | 26-14 AWG | 26-12 AWG | 26-14 AWG | |
| | Crimp Terminal Stripping Length | N/A | 7.5 mm | 8 mm | 7.5 mm | N/A | | |
| Aluminum Hoods/Bases/Couplers/Covers | Material | Die cast aluminum alloy, Polyester powder coated | | | | | | |
| | Locking Element | Stainless steel lever and peg | | | | | | |
| | Housings Seal | NBR (Nitrile) | | | | | | |
| | Degree of Protection Acc. to EN 60529 (coupled) NEMA 250, UL50, 50E | IP66, NEMA/UL (Type 1, 4, 4X, 12) | | | | | | |
| | Temperature Range | -40°C to 125°C (-40°F to 257°F) | | | | | | |
| | Thread | Metric EN50262 Pg DIN 40430 | | | | | | |

* Connectors should not be coupled and decoupled under electrical load.



STD Series Multi-Wire Connectors, Size 3A



| Inserts | | | | | | |
|-------------|---------------------|------------------|------------------|-------------------|-------------------|-------------------|
| Insert Type | No. of Poles | 3+PE | 4+PE | 5+PE | 7+PE | 12+PE |
| | Rated Voltage AC/DC | 600V | 600V | 600V | 600V | 600V |
| | Max. Rated Current | 10A | 10A | 16A | 10A | 10A |
| | Termination Type | Screw Terminals | Screw Terminals | Crimp Contacts* | Crimp Contacts* | Crimp Contacts* |
| Male | Part No. | ZP-MC03A-1-MS003 | ZP-MC03A-1-MS004 | ZP-MC03A-1-MC005 | ZP-MC03A-1-MC007 | ZP-MC03A-1-MC012 |
| | Price | <---> | <---> | <---> | <---> | <---> |
| | Contact Size | N/A | N/A | ZP-MC-CC-M16A-XX* | ZP-MC-CC-M10A-XX* | ZP-MC-CC-M10A-XX* |
| | Weight (lb.) | 0.284 | 0.295 | 0.031 | 0.163 | 0.029 |
| Female | Part No. | ZP-MC03A-1-FS003 | ZP-MC03A-1-FS004 | ZP-MC03A-1-FC005 | ZP-MC03A-1-FC007 | ZP-MC03A-1-FC012 |
| | Price | <---> | <---> | <---> | <---> | <---> |
| | Contact Size | N/A | N/A | ZP-MC-CC-F16A-XX* | ZP-MC-CC-F10A-XX* | ZP-MC-CC-F10-XX* |
| | Weight (lb.) | 0.275 | 0.302 | 0.031 | 0.143 | 0.031 |

* Crimp Contacts must be purchased separately. The XX represents wire AWG. See Accessories section for complete part numbers.

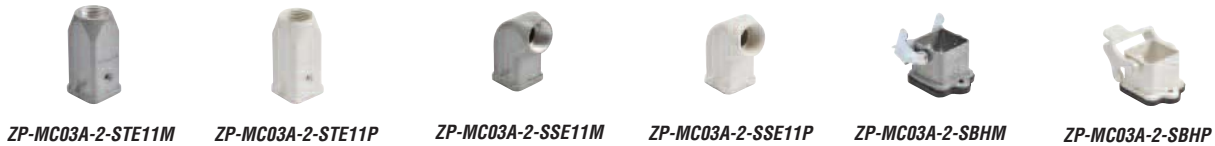

| Hoods, Bases, Couplers and Covers | | | | | Accessories*** |
|-----------------------------------|------------------------|-------------------------|-------|--------------|------------------|
| Housing Component | Threaded Opening** | Part No. | Price | Weight (lb.) | Plug with Gasket |
| Aluminum | Straight Hood | Pg 11 ZP-MC03A-2-STE11M | <---> | 0.050 | ZP-MC-PLG-11M8 |
| | Angled Hood | Pg 11 ZP-MC03A-2-SSE11M | <---> | 0.048 | ZP-MC-PLG-11M8 |
| | Bulkhead Straight Base | N/A ZP-MC03A-2-SBHM | <---> | 0.044 | N/A |
| | Bulkhead Angled Base | N/A ZP-MC03A-2-SBHAM | <---> | 0.055 | N/A |
| | Surface Mount Base | Pg 11 ZP-MC03A-2-SSM11M | <---> | 0.070 | ZP-MC-PLG-11M8 |
| | Coupler | Pg 11 ZP-MC03A-2-SCP11M | <---> | 0.068 | ZP-MC-PLG-11M8 |
| | Cover - Male Insert | N/A ZP-MC03A-2-SCVPMM | <---> | 0.015 | N/A |
| | Cover - Female Insert | N/A ZP-MC03A-2-SCVPFM | <---> | 0.019 | N/A |
| Thermoplastic | Straight Hood | Pg 11 ZP-MC03A-2-STE11P | <---> | 0.028 | N/A |
| | Angled Hood | Pg 11 ZP-MC03A-2-SSE11P | <---> | 0.026 | |
| | Bulkhead Straight Base | N/A ZP-MC03A-2-SBHP | <---> | 0.024 | |
| | Bulkhead Angled Base | N/A ZP-MC03A-2-SBHAP | <---> | 0.030 | |
| | Surface Mount Base | Pg 11 ZP-MC03A-2-SSM11P | <---> | 0.039 | |
| | Coupler | Pg 11 ZP-MC03A-2-SCP11P | <---> | 0.033 | |
| | Cover - Male Insert | N/A ZP-MC03A-2-SCVPMP | <---> | 0.008 | |
| | Cover - Female Insert | N/A ZP-MC03A-2-SCVPFP | <---> | 0.008 | |

** To convert to NPT, select a Pg to NPT Adapter.

***Accessories pricing and details can be found in the Accessories section.



STD Series Multi-Wire Connectors, Size 3A



ZP-MC03A-2-SBHAM



ZP-MC03A-2-SBHAP



ZP-MC03A-2-SSM11M



ZP-MC03A-2-SSM11P



ZP-MC03A-2-SCP11M



ZP-MC03A-2-SCP11P



ZP-MC03A-2-SCVPMM



ZP-MC03A-2-SCVPMP



ZP-MC03A-2-SCVPFM



ZP-MC03A-2-SCVPFP



IP66 Cable Gland



IP68 Cable Gland



PG to NPT Adapter



Plug with Gasket

Accessories*** Continued

| Housing Component | | IP66 Cable Glands | IP68 Cable Glands | Pg to NPT Adapter | |
|-------------------|-------------------------------|-------------------|-------------------|-------------------|---------------|
| | | | | Pg 11 to 3/8" | Pg 11 to 1/2" |
| Aluminum | Straight Hood | ZP-MC-CG-11M5 | ZP-MC-CG-11M8 | ZP-MC-A-11038 | ZP-MC-A-11012 |
| | Angled Hood | ZP-MC-CG-11M5 | ZP-MC-CG-11M8 | ZP-MC-A-11038 | ZP-MC-A-11012 |
| | Bulkhead Straight Base | ZP-MC-CG-11M5 | ZP-MC-CG-11M8 | ZP-MC-A-11038 | ZP-MC-A-11012 |
| | Bulkhead Angled Base | N/A | N/A | N/A | N/A |
| | Surface Mount Base | ZP-MC-CG-11M5 | ZP-MC-CG-11M8 | ZP-MC-A-11038 | ZP-MC-A-11012 |
| | Coupler | ZP-MC-CG-11M5 | ZP-MC-CG-11M8 | ZP-MC-A-11038 | ZP-MC-A-11012 |
| | Cover - Male Insert | N/A | N/A | N/A | N/A |
| | Cover - Female Insert | N/A | N/A | N/A | N/A |
| Thermoplastic | Straight Hood | ZP-MC-CG-11P5 | N/A | N/A | N/A |
| | Angled Hood | ZP-MC-CG-11P5 | N/A | N/A | N/A |
| | Bulkhead Straight Base | ZP-MC-CG-11P5 | N/A | N/A | N/A |
| | Bulkhead Angled Base | N/A | N/A | N/A | N/A |
| | Surface Mount Base | ZP-MC-CG-11P5 | N/A | N/A | N/A |
| | Coupler | ZP-MC-CG-11P5 | N/A | N/A | N/A |
| | Cover - Male Insert | N/A | N/A | N/A | N/A |
| | Cover - Female Insert | N/A | N/A | N/A | N/A |

*** Accessories pricing and details can be found in the Accessories section.



STD Series Multi-Wire Connectors, Size 10A



ZP-MC10A-1-MS010



ZP-MC10A-1-FS010



ZP-MC10A-1-MC010



ZP-MC10A-1-FC010



ZP-MC10A-1-MC015



ZP-MC10A-1-FC015

| Inserts | | | | |
|-------------|---------------------|------------------|------------------|------------------|
| Insert Type | No. of Poles | 10+PE | | 15+PE |
| | Rated Voltage AC/DC | 600V | | 600V |
| | Max. Rated Current | 16A | | 10A |
| | Termination Type | Screw Terminals | Crimp Contacts* | Crimp Contacts* |
| Male | Part No. | ZP-MC10A-1-MS010 | ZP-MC10A-1-MC010 | ZP-MC10A-1-MC015 |
| | Price | <--> | <--> | <--> |
| | Contact Size | N/A | ZP-MC-CC-M16A-XX | ZP-MC-CC-M10A-XX |
| | Weight (lb.) | 0.101 | 0.046 | 0.066 |
| Female | Part No. | ZP-MC10A-1-FS010 | ZP-MC10A-1-FC010 | ZP-MC10A-1-FC015 |
| | Price | <--> | <--> | <--> |
| | Contact Size | N/A | ZP-MC-CC-F16A-XX | ZP-MC-CC-F10A-XX |
| | Weight (lb.) | 0.106 | 0.051 | 0.066 |

* Crimp Contacts must be purchased separately. The XX represents wire AWG. See Accessories section for complete part numbers.



ZP-MC10A-2-STE13M



ZP-MC10A-2-SSE16M



ZP-MC10A-2-SBHM



ZP-MC10A-2-SBHMC



ZP-MC10A-2-SSM16M



ZP-MC10A-2-SSM16MC

| Hoods, Bases, Couplers and Covers | | | | | Accessories** |
|-------------------------------------|--------------------|--------------------|-------|--------------|------------------|
| Housing Component | Threaded Opening** | Part No. | Price | Weight (lb.) | Plug with Gasket |
| Top Entry Hood | Pg 13.5 | ZP-MC10A-2-STE13M | <--> | 0.209 | ZP-MC-PLG-13M8 |
| | Pg 16 | ZP-MC10A-2-STE16M | <--> | 0.205 | ZP-MC-PLG-16M8 |
| | Pg 16 HC | ZP-MC10A-2-STE16ML | <--> | 0.306 | ZP-MC-PLG-16M8 |
| | Pg 21 HC | ZP-MC10A-2-STE21ML | <--> | 0.299 | ZP-MC-PLG-21M8 |
| Side Entry Hood | Pg 16 | ZP-MC10A-2-SSE16M | <--> | 0.216 | ZP-MC-PLG-16M8 |
| | Pg 16 HC | ZP-MC10A-2-SSE16ML | <--> | 0.295 | ZP-MC-PLG-16M8 |
| | Pg 21 HC | ZP-MC10A-2-SSE21ML | <--> | 0.291 | ZP-MC-PLG-21M8 |
| Bulkhead | N/A | ZP-MC10A-2-SBHM | <--> | 0.165 | N/A |
| Bulkhead w/Cover | N/A | ZP-MC10A-2-SBHMC | <--> | 0.262 | N/A |
| Surface Mounting Housing | Pg 16x2 | ZP-MC10A-2-SSM16M | <--> | 0.373 | ZP-MC-PLG-16M8 |
| | Pg 21x2 | ZP-MC10A-2-SSM21M | <--> | 0.329 | ZP-MC-PLG-21M8 |
| Surface Mounting Housing/with Cover | Pg 16x2 | ZP-MC10A-2-SSM16MC | <--> | 0.463 | ZP-MC-PLG-16M8 |
| | Pg 21x2 | ZP-MC10A-2-SSM21MC | <--> | 0.432 | ZP-MC-PLG-21M8 |
| Cover w/Pegs - 1 Lever | N/A | ZP-MC10A-2-SCVLM | <--> | 0.124 | N/A |
| Cover w/Pegs - 2 Pegs | N/A | ZP-MC10A-2-SCVPM | <--> | 0.059 | N/A |

HC = High Construction

** To convert to NPT, select a Pg to NPT adapter.

*** Accessories pricing and details can be found in the Accessories section.



STD Series Multi-Wire Connectors, Size 10A



Single Lever Cover



IP66 Cable Gland



IP68 Cable Gland



PG to NPT Adapter



Plug with Gasket

Accessories*** Continued

| Housing Component | | IP66 Cable Glands | IP68 Cable Glands | Pg to NPT Adapter | | |
|---|--------------------------|-------------------|-------------------|-------------------|---------------|---------------|
| | | | | Pg 13.5 to 1/2" | Pg 16 to 1/2" | Pg 21 to 3/4" |
| Single Lever | Top Entry Hood | ZP-MC-CG-13M5 | ZP-MC-CG-13M8 | ZP-MC-A-13012 | N/A | N/A |
| | | ZP-MC-CG-16M5 | ZP-MC-CG-16M8 | N/A | ZP-MC-A-16012 | N/A |
| | | N/A | ZP-MC-CG-16M8 | N/A | ZP-MC-A-16012 | N/A |
| | | N/A | ZP-MC-CG-21M8 | N/A | N/A | ZP-MC-A-21034 |
| | Side Entry Hood | ZP-MC-CG-16M5 | ZP-MC-CG-16M8 | N/A | ZP-MC-A-16012 | N/A |
| | | N/A | ZP-MC-CG-16M8 | N/A | ZP-MC-A-16012 | N/A |
| | | N/A | ZP-MC-CG-21M8 | N/A | N/A | ZP-MC-A-21034 |
| | Bulkhead | N/A | N/A | N/A | N/A | N/A |
| | Bulkhead w/Cover | N/A | N/A | N/A | N/A | N/A |
| | Surface Mounting Housing | N/A | ZP-MC-CG-16M8 | N/A | ZP-MC-A-16012 | N/A |
| N/A | | ZP-MC-CG-21M8 | N/A | N/A | ZP-MC-A-21034 | |
| Surface Mounting Housing/ with Cover | N/A | ZP-MC-CG-16M8 | N/A | ZP-MC-A-16012 | N/A | |
| | N/A | ZP-MC-CG-21M8 | N/A | N/A | ZP-MC-A-21034 | |
| Cover w/Pegs - 1 Lever | N/A | N/A | N/A | N/A | N/A | |
| Cover w/Pegs - 2 Pegs | N/A | N/A | N/A | N/A | N/A | |

*** Accessories pricing and details can be found in the Accessories section.



STD Series Multi-Wire Connectors, Size 16A



ZP-MC16A-1-MS016



ZP-MC16A-1-FS016



ZP-MC16A-1-MC016



ZP-MC16A-1-FC016



ZP-MC16A-1-MC025



ZP-MC16A-1-FC025

| Inserts | | | | |
|-------------|---------------------|------------------|------------------|------------------|
| Insert Type | No. of Poles | 16+PE | | 25+PE |
| | Rated Voltage AC/DC | 600V | | 600V |
| | Max. Rated Current | 16A | | 10A |
| | Termination Type | Screw Terminal | Crimp Contacts* | Crimp Contacts* |
| Male | Part No. | ZP-MC16A-1-MS016 | ZP-MC16A-1-MC016 | ZP-MC16A-1-MC025 |
| | Price | <--> | <--> | <--> |
| | Contact Size | N/A | ZP-MC-CC-M16A-XX | ZP-MC-CC-M10A-XX |
| | Weight (lb.) | 0.139 | 0.064 | 0.079 |
| Female | Part No. | ZP-MC16A-1-FS016 | ZP-MC16A-1-FC016 | ZP-MC16A-1-FC025 |
| | Price | <--> | <--> | <--> |
| | Contact Size | N/A | ZP-MC-CC-F16A-XX | ZP-MC-CC-F10A-XX |
| | Weight (lb.) | 0.148 | 0.068 | 0.086 |

* Crimp Contacts must be purchased separately. The XX represents wire AWG. See Accessories section for complete part numbers.



ZP-MC16A-2-STE13M



ZP-MC16A-2-SSE16M



ZP-MC16A-2-SBHM



ZP-MC16A-2-SBHMC



ZP-MC16A-2-SSM16M



ZP-MC16A-2-SSM21MC

| Hoods, Bases, Couplers and Covers | | | | | Accessories** |
|-------------------------------------|--------------------|--------------------|-------|--------------|------------------|
| Housing Component | Threaded Opening** | Part No. | Price | Weight (lb.) | Plug with Gasket |
| Top Entry Hood | Pg 13.5 | ZP-MC16A-2-STE13M | <--> | 0.232 | ZP-MC-PLG-13M8 |
| | Pg 16 | ZP-MC16A-2-STE16M | <--> | 0.234 | ZP-MC-PLG-16M8 |
| | Pg 16 HC | ZP-MC16A-2-STE16ML | <--> | 0.388 | ZP-MC-PLG-16M8 |
| | Pg 21 HC | ZP-MC16A-2-STE21ML | <--> | 0.373 | ZP-MC-PLG-21M8 |
| Side Entry Hood | Pg 16 | ZP-MC16A-2-SSE16M | <--> | 0.254 | ZP-MC-PLG-16M8 |
| | Pg 16 HC | ZP-MC16A-2-SSE16ML | <--> | 0.381 | ZP-MC-PLG-16M8 |
| | Pg 21 HC | ZP-MC16A-2-SSE21ML | <--> | 0.366 | ZP-MC-PLG-21M8 |
| Bulkhead | N/A | ZP-MC16A-2-SBHM | <--> | 0.185 | N/A |
| Bulkhead w/Cover | N/A | ZP-MC16A-2-SBHMC | <--> | 0.298 | N/A |
| Surface Mounting Housing | Pg 16x2 | ZP-MC16A-2-SSM16M | <--> | 0.445 | ZP-MC-PLG-16M8 |
| | Pg 21x2 | ZP-MC16A-2-SSM21M | <--> | 0.403 | ZP-MC-PLG-21M8 |
| Surface Mounting Housing/with Cover | Pg 16 | ZP-MC16A-2-SSM16MC | <--> | 0.558 | ZP-MC-PLG-16M8 |
| | Pg 21 | ZP-MC16A-2-SSM21MC | <--> | 0.518 | ZP-MC-PLG-21M8 |
| Cover w/Pegs - 1 Lever | N/A | ZP-MC16A-2-SCVLM | <--> | 0.145 | N/A |
| Cover w/Pegs - 2 Pegs | N/A | ZP-MC16A-2-SCVPM | <--> | 0.068 | N/A |

HC = High Construction

** To convert to NPT, select a Pg to NPT adapter.

*** Accessories pricing and details can be found in the Accessories section.



STD Series Multi-Wire Connectors, Size 16A



Single Lever Cover



IP66 Cable Gland



IP68 Cable Gland



PG to NPT Adapter



Plug with Gasket

| Accessories*** Continued | | | | | | |
|---|--------------------------|-------------------|-------------------|-------------------|---------------|---------------|
| Housing Component | | IP66 Cable Glands | IP68 Cable Glands | Pg to NPT Adapter | | |
| | | | | Pg 13.5 to 1/2" | Pg 16 to 1/2" | Pg 21 to 3/4" |
| Single Lever | Top Entry Hood | ZP-MC-CG-13M5 | ZP-MC-CG-13M8 | ZP-MC-A-13012 | N/A | N/A |
| | | ZP-MC-CG-16M5 | ZP-MC-CG-16M8 | N/A | ZP-MC-A-16012 | N/A |
| | | N/A | ZP-MC-CG-16M8 | N/A | ZP-MC-A-16012 | N/A |
| | | N/A | ZP-MC-CG-21M8 | N/A | N/A | ZP-MC-A-21034 |
| | Side Entry Hood | ZP-MC-CG-16M5 | ZP-MC-CG-16M8 | N/A | ZP-MC-A-16012 | N/A |
| | | N/A | ZP-MC-CG-16M8 | N/A | ZP-MC-A-16012 | N/A |
| | | N/A | ZP-MC-CG-21M8 | N/A | N/A | ZP-MC-A-21034 |
| | Bulkhead | N/A | N/A | N/A | N/A | N/A |
| | Bulkhead w/Cover | N/A | N/A | N/A | N/A | N/A |
| | Surface Mounting Housing | N/A | ZP-MC-CG-16M8 | N/A | ZP-MC-A-16012 | N/A |
| N/A | | ZP-MC-CG-21M8 | N/A | N/A | ZP-MC-A-21034 | |
| Surface Mounting Housing/ with Cover | N/A | ZP-MC-CG-16M8 | N/A | ZP-MC-A-16012 | N/A | |
| | N/A | ZP-MC-CG-21M8 | N/A | N/A | ZP-MC-A-21034 | |
| Cover w/Pegs - 1 Lever | N/A | N/A | N/A | N/A | N/A | |
| Cover w/Pegs - 2 Pegs | N/A | N/A | N/A | N/A | N/A | |

*** Accessories pricing and details can be found in the Accessories section.



STD Series Multi-Wire Connectors, Size 6B



ZP-MC06B-1-MS006



ZP-MC06B-1-FS006



ZP-MC06B-1-MC006



ZP-MC06B-1-FC006



ZP-MC06B-1-MC024



ZP-MC06B-1-FC024

| Inserts | | | | |
|-------------|---------------------|------------------|-------------------|-------------------|
| Insert Type | No. of Poles | 6+PE | | 24+PE |
| | Rated Voltage AC/DC | 600 Volts | | 600 Volts |
| | Max. Rated Current | 16 Amps | | 10 Amps |
| | Termination Type | Screw Terminals | Crimp Contacts* | Crimp Contacts* |
| Male | Part No. | ZP-MC06B-1-MS006 | ZP-MC06B-1-MC006 | ZP-MC06B-1-MC024 |
| | Price | <---> | <---> | <---> |
| | Contact Size | N/A | ZP-MC-CC-M16A-XX* | ZP-MC-CC-M10A-XX* |
| | Weight (lb.) | 0.103 | 0.081 | 0.083 |
| Female | Part No. | ZP-MC06B-1-FS006 | ZP-MC06B-1-FC006 | ZP-MC06B-1-FC024 |
| | Price | <---> | <---> | <---> |
| | Contact Size | N/A | ZP-MC-CC-F16A-XX* | ZP-MC-CC-F10A-XX* |
| | Weight (lb.) | 0.101 | 0.081 | 0.081 |

*Crimp contacts must be purchased separately. The XX represents wire AWG. See Accessories section for complete part numbers.

| Hoods, Bases, Couplers and Covers | | | | | Accessories*** | |
|-----------------------------------|----------------------------------|-------------------|--------------------|--------------|------------------|----------------|
| Housing Component | Threaded Opening** | Part No. | Price | Weight (lb.) | Plug with Gasket | |
| Single Lever | Top Entry Hood (2 Pegs) | Pg 16 | ZP-MC06B-2-STE16M | <---> | 0.200 | ZP-MC-PLG-16M8 |
| | | Pg 21 HC | ZP-MC06B-2-STE21ML | <---> | 0.368 | ZP-MC-PLG-21M8 |
| | | Pg 29 HC | ZP-MC06B-2-STE29ML | <---> | 0.343 | ZP-MC-PLG-29M8 |
| | Side Entry Hood (2 Pegs) | Pg 16 | ZP-MC06B-2-SSE16M | <---> | 0.205 | ZP-MC-PLG-16M8 |
| | | Pg 21 HC | ZP-MC06B-2-SSE21ML | <---> | 0.366 | ZP-MC-PLG-21M8 |
| | | Pg 29 HC | ZP-MC06B-2-SSE29ML | <---> | 0.350 | ZP-MC-PLG-29M8 |
| | Surface Mount Base | Pg 16x2 | ZP-MC06B-2-SSM16M | <---> | 0.421 | ZP-MC-PLG-16M8 |
| | | Pg 21x2 HC | ZP-MC06B-2-SSM21ML | <---> | 0.654 | ZP-MC-PLG-21M8 |
| | | Pg 29x2 HC | ZP-MC06B-2-SSM29ML | <---> | 0.575 | ZP-MC-PLG-29M8 |
| | Surface Mount w/Cover | Pg 16x2 | ZP-MC06B-2-SSM16C | <---> | 0.545 | ZP-MC-PLG-16M8 |
| | | Pg 21x2 HC | ZP-MC06B-2-SSM21CL | <---> | 0.783 | ZP-MC-PLG-21M8 |
| | | Pg 29x2 HC | ZP-MC06B-2-SSM29CL | <---> | 0.681 | ZP-MC-PLG-29M8 |
| | Surface Mount w/ Automatic Cover | Pg 16x2 | ZP-MC06B-2-SSM16CA | <---> | 0.805 | ZP-MC-PLG-16M8 |
| | | Pg 21x2 HC | ZP-MC06B-2-SSM21CA | <---> | 0.948 | ZP-MC-PLG-21M8 |
| | | Pg 29x2 HC | ZP-MC06B-2-SSM29CA | <---> | 0.946 | ZP-MC-PLG-29M8 |
| | Bulkhead Base | N/A | ZP-MC06B-2-SBHM | <---> | 0.207 | N/A |
| | Bulkhead w/Cover | N/A | ZP-MC06B-2-SBHC | <---> | 0.351 | N/A |
| | Bulkhead w/Auto Cover | N/A | ZP-MC06B-2-SBHCA | <---> | 0.496 | N/A |
| Coupler (Single Lever) | Pg 16 | ZP-MC06B-2-SCP16M | <---> | 0.295 | ZP-MC-PLG-16M8 | |
| Cover (Single Lever) | N/A | ZP-MC06B-2-SCVLM | <---> | 0.167 | N/A | |
| Cover (2 Pegs) | N/A | ZP-MC06B-2-SCVPM | <---> | 0.108 | N/A | |

HC = High Construction

** To convert to NPT, select a Pg to NPT adapter.

*** Accessories pricing and details can be found in the Accessories section.



STD Series Multi-Wire Connectors, Size 6B



Single Lever Coupler



Single Lever Cover



IP66 Cable Gland



IP68 Cable Gland



PG to NPT Adapter



Plug with Gasket



Single Lever Top Entry Hood



Single Lever Top Entry Hood High Capacity



Single Lever Side Entry Hood



Single Lever Side Entry Hood High Capacity



Single Lever Surface Mount Base



Single Lever Surface Mount Base High Capacity



Single Lever Bulkhead Base

Accessories*** Continued

| Housing Component | | IP66 Cable Glands | IP68 Cable Glands | Pg to NPT Adapter | | | |
|------------------------|----------------------------------|-------------------|-------------------|-------------------|---------------|---------------|-----------------|
| | | | | Pg 16 to 1/2" | Pg 21 to 3/4" | Pg 29 to 1" | Pg 29 to 1 1/4" |
| Single Lever / 2 Pegs | Top Entry Hood (2 Pegs) | ZP-MC-CG-16M5 | ZP-MC-CG-16M8 | ZP-MC-A-16012 | N/A | N/A | N/A |
| | | N/A | ZP-MC-CG-21M8 | N/A | ZP-MC-A-21034 | N/A | N/A |
| | | N/A | ZP-MC-CG-29M8 | N/A | N/A | ZP-MC-A-29100 | ZP-MC-A-29114 |
| | Side Entry Hood (2 Pegs) | ZP-MC-CG-16M5 | ZP-MC-CG-16M8 | ZP-MC-A-16012 | N/A | N/A | N/A |
| | | N/A | ZP-MC-CG-21M8 | N/A | ZP-MC-A-21034 | N/A | N/A |
| | | N/A | ZP-MC-CG-29M8 | N/A | N/A | ZP-MC-A-29100 | ZP-MC-A-29114 |
| | Surface Mount Base | ZP-MC-CG-16M5 | ZP-MC-CG-16M8 | ZP-MC-A-16012 | N/A | N/A | N/A |
| | | ZP-MC-CG-21M4 | ZP-MC-CG-21M8 | N/A | ZP-MC-A-21034 | N/A | N/A |
| | | ZP-MC-CG-29M5 | ZP-MC-CG-29M8 | N/A | N/A | ZP-MC-A-29100 | ZP-MC-A-29114 |
| | Surface Mount w/Cover | ZP-MC-CG-16M5 | ZP-MC-CG-16M8 | ZP-MC-A-16012 | N/A | N/A | N/A |
| | | ZP-MC-CG-21M5 | ZP-MC-CG-21M8 | N/A | ZP-MC-A-21034 | N/A | N/A |
| | | ZP-MC-CG-29M5 | ZP-MC-CG-29M8 | N/A | N/A | ZP-MC-A-29100 | ZP-MC-A-29100 |
| | Surface Mount /w Automatic Cover | ZP-MC-CG-16M5 | ZP-MC-CG-16M8 | ZP-MC-A-16012 | N/A | N/A | N/A |
| | | ZP-MC-CG-21M5 | ZP-MC-CG-21M8 | N/A | ZP-MC-A-21034 | N/A | N/A |
| ZP-MC-CG-29M5 | | ZP-MC-CG-29M8 | N/A | N/A | ZP-MC-A-29100 | ZP-MC-A-29100 | |
| Bulkhead Base | N/A | N/A | N/A | N/A | N/A | N/A | |
| Bulkhead w/Cover | N/A | N/A | N/A | N/A | N/A | N/A | |
| Bulkhead w/Auto Cover | N/A | N/A | N/A | N/A | N/A | N/A | |
| Coupler (Single Lever) | ZP-MC-CG-16M5 | ZP-MC-CG-16M8 | ZP-MC-A-16012 | N/A | N/A | N/A | |
| Cover (Single Lever) | N/A | N/A | N/A | N/A | N/A | N/A | |
| Cover (2 Pegs) | N/A | N/A | N/A | N/A | N/A | N/A | |

*** Accessories pricing and details can be found in the Accessories section.



STD Series Multi-Wire Connectors, Size 10B



Company Information

Systems Overview

Programmable Controllers

Field I/O

Software

C-more & other HMI

Drives

Soft Starters

Motors & Gearbox

Steppers/Servos

Motor Controls

Proximity Sensors

Photo Sensors

Limit Switches

Encoders

Current Sensors

Pressure Sensors

Temperature Sensors

Pushbuttons/Lights

Process

Relays/Timers

Comm.

Terminal Blocks & Wiring

Power

Circuit Protection

Enclosures

Tools

Pneumatics

Safety

Appendix

Product Index

| Inserts | | | | |
|-------------|---------------------|------------------|-------------------|-------------------|
| Insert Type | No. of Poles | 10+PE | | 42+PE |
| | Rated Voltage AC/DC | 600 Volts | | 600 Volts |
| | Max. Rated Current | 16 Amps | | 10 Amps |
| | Termination Type | Screw Terminals | Crimp Contacts* | Crimp Contacts* |
| Male | Part No. | ZP-MC10B-1-MS010 | ZP-MC10B-1-MC010 | ZP-MC10B-1-MC042 |
| | Price | <--> | <--> | <--> |
| | Contact Size | N/A | ZP-MC-CC-M16A-XX* | ZP-MC-CC-M10A-XX* |
| | Weight (lb.) | 0.134 | 0.099 | 0.099 |
| Female | Part No. | ZP-MC10B-1-FS010 | ZP-MC10B-1-FC010 | ZP-MC10B-1-FC042 |
| | Price | <--> | <--> | <--> |
| | Contact Size | N/A | ZP-MC-CC-M16A-XX* | ZP-MC-CC-M10A-XX* |
| | Weight (lb.) | 0.134 | 0.099 | 0.103 |

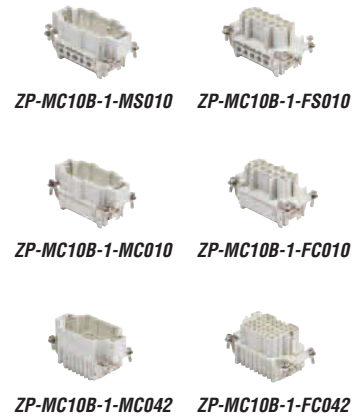

*Crimp contacts must be purchased separately. The XX represents wire AWG. See Accessories section for complete part numbers.

| Hoods, Bases, Couplers and Covers | | | | | | Accessories*** | |
|-----------------------------------|---|---------------------|--------------------|--------------------|--------------|-------------------|--------------------|
| Housing Component | | Threading Opening** | Part No. | Price | Weight (lb.) | Plugs with Gasket | |
| Single Lever / 2 Pegs | Top Entry Hood (2 Pegs) | Pg 16 | ZP-MC10B-2-STE16M | <--> | 0.271 | ZP-MC-PLG-16M8 | |
| | | Pg 21 HC | ZP-MC10B-2-STE21ML | <--> | 0.432 | ZP-ML-PLG-21M8 | |
| | | Pg 29 HC | ZP-MC10B-2-STE29ML | <--> | 0.410 | ZP-ML-PLG-29M8 | |
| | Side Entry Hood (2 Pegs) | Pg 16 | ZP-MC10B-2-SSE16M | <--> | 0.255 | ZP-MC-PLG-16M8 | |
| | | Pg 21 HC | ZP-MC10B-2-SSE21ML | <--> | 0.416 | ZP-ML-PLG-21M8 | |
| | | Pg 29 HC | ZP-MC10B-2-SSE29ML | <--> | 0.394 | ZP-ML-PLG-29M8 | |
| | Surface Mount Base | Pg 16x2 | ZP-MC10B-2-SSM16M | <--> | 0.509 | ZP-MC-PLG-16M8 | |
| | | Pg 21x2 HC | ZP-MC10B-2-SSM21ML | <--> | 0.637 | ZP-ML-PLG-21M8 | |
| | | Pg 29x2 HC | ZP-MC10B-2-SSM29ML | <--> | 0.637 | ZP-ML-PLG-29M8 | |
| | Surface Mount w/Cover | Pg 16x2 | ZP-MC10B-2-SSM16C | <--> | 0.655 | ZP-MC-PLG-16M8 | |
| | | Pg 21x2 HC | ZP-MC10B-2-SSM21CL | <--> | 0.873 | ZP-ML-PLG-21M8 | |
| | | Pg 29x2 HC | ZP-MC10B-2-SSM29CL | <--> | 0.794 | ZP-ML-PLG-29M8 | |
| | Surface Mount w/Automatic Cover | Pg 16x2 | ZP-MC10B-2-SSM16CA | <--> | 0.697 | ZP-MC-PLG-16M8 | |
| | | Pg 21x2 HC | ZP-MC10B-2-SSM21CA | <--> | 1.041 | ZP-ML-PLG-21M8 | |
| | | Pg 29x2 HC | ZP-MC10B-2-SSM29CA | <--> | 1.027 | ZP-ML-PLG-29M8 | |
| | Bulkhead Base (Single Lever) | | N/A | ZP-MC10B-2-SBHM | <--> | 0.245 | N/A |
| | Bulkhead w/Cover (Single Lever) | | N/A | ZP-MC10B-2-SBHC | <--> | 0.401 | N/A |
| | Bulkhead w/Automatic Cover (Single Cover) | | N/A | ZP-MC10B-2-SBHCA | <--> | 0.520 | N/A |
| Coupler (Single Lever) | | Pg 16 | ZP-MC10B-2-SCP16M | <--> | 0.379 | ZP-ML-PLG-16M8 | |
| Cover (Single Lever) | | N/A | ZP-MC10B-2-SCVLM | <--> | 0.200 | N/A | |
| Cover (2 Pegs) | | N/A | ZP-MC10B-2-SCVPM | <--> | 0.108 | N/A | |
| Double Lever / 4 Pegs | Top Entry Hood (4 Pegs) | Pg 16 | ZP-MC10B-2-DTE16M | <--> | 0.262 | ZP-MC-PLG-16M8 | |
| | | Pg 21 HC | ZP-MC10B-2-DTE21ML | <--> | 0.432 | ZP-ML-PLG-21M8 | |
| | | Pg 29 HC | ZP-MC10B-2-DTE29ML | <--> | 0.407 | ZP-ML-PLG-29M8 | |
| | Top Double Entry Hood (4 Pegs) | | Pg 13.5x2 HC | ZP-MC10B-2-DTE13M2 | <--> | 0.459 | ZP-MC-PLG-13M8**** |
| | Side Entry Hood (4 Pegs) | Pg 16 | ZP-MC10B-2-DSE16M | <--> | 0.260 | ZP-MC-PLG-16M8 | |
| | | Pg 21 HC | ZP-MC10B-2-DSE21ML | <--> | 0.421 | ZP-ML-PLG-21M8 | |
| | | Pg 29 HC | ZP-MC10B-2-DSE29ML | <--> | 0.399 | ZP-ML-PLG-29M8 | |
| | Surface Mount Base (4 Peg) | Pg 16x2 | ZP-MC10B-2-DSM16M | <--> | 0.537 | ZP-MC-PLG-16M8 | |
| | | Pg 21x2 HC | ZP-MC10B-2-DSM21ML | <--> | 0.676 | ZP-ML-PLG-21M8 | |
| | | Pg 29x2 HC | ZP-MC10B-2-DSM29ML | <--> | 0.663 | ZP-ML-PLG-29M8 | |
| | Bulkhead Base (Double Lever) | | N/A | ZP-MC10B-2-DBHM | <--> | 0.277 | N/A |
| | Coupler (Double Lever) | Pg 16 | ZP-MC10B-2-DCP16M | <--> | 0.429 | ZP-MC-PLG-16M8 | |
| | | Pg 21 HC | ZP-MC10B-2-DCP21ML | <--> | 0.599 | ZP-MC-PLG-21M8 | |
| | Cover (Double Lever) | | N/A | ZP-MC10B-2-DCVLM | <--> | 0.235 | N/A |
| | Cover (4 Peg) | | N/A | ZP-MC10B-2-DCVPM | <--> | 0.101 | N/A |

** To convert to NPT, select a Pg to NPT adapter.

*** Accessories pricing and details can be found in the Accessories section.

**** There are 2 openings per hood.

HC = High Construction



STD Series Multi-Wire Connectors, Size 10B

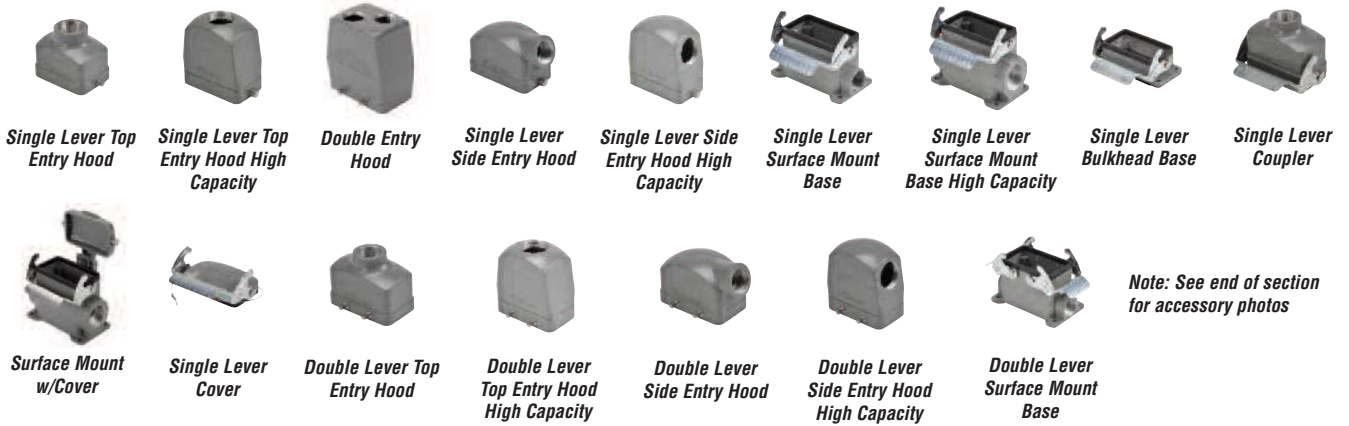

| Accessories*** Continued | | | | | | | |
|---|---------------------------------|-------------------|-------------------|---------------------|---------------|---------------|-----------------|
| Housing Component | | IP66 Cable Glands | IP68 Cable Glands | Pg to NPT Adapter | | | |
| | | | | Pg13.5/Pg16 to 1/2" | Pg 21 to 3/4" | Pg 29 to 1" | Pg 29 to 1 1/4" |
| Single Lever / 2 Pegs | Top Entry Hood (2 Pegs) | ZP-MC-CG-16M5 | ZP-MC-CG-16M8 | ZP-MC-A-16012 | N/A | N/A | N/A |
| | | N/A | ZP-MC-CG-21M8 | N/A | ZP-MC-A-21034 | N/A | N/A |
| | | N/A | ZP-MC-CG-29M8 | N/A | N/A | ZP-MC-A-29100 | ZP-MC-A-29114 |
| | Side Entry Hood (2 Pegs) | ZP-MC-CG-16M5 | ZP-MC-CG-16M8 | ZP-MC-A-16012 | N/A | N/A | N/A |
| | | N/A | ZP-MC-CG-21M8 | N/A | ZP-MC-A-21034 | N/A | N/A |
| | | N/A | ZP-MC-CG-29M8 | N/A | N/A | ZP-MC-A-29100 | ZP-MC-A-29114 |
| | Surface Mount Base | ZP-MC-CG-16M5 | ZP-MC-CG-16M8 | ZP-MC-A-16012 | N/A | N/A | N/A |
| | | ZP-MC-CG-21M5 | ZP-MC-CG-21M8 | N/A | ZP-MC-A-21034 | N/A | N/A |
| | | ZP-MC-CG-29M5 | ZP-MC-CG-29M8 | N/A | N/A | ZP-MC-A-29100 | ZP-MC-A-29114 |
| | Surface Mount w/Cover | ZP-MC-CG-16M5 | ZP-MC-CG-16M8 | ZP-MC-A-16012 | N/A | N/A | N/A |
| | | ZP-MC-CG-21M5 | ZP-MC-CG-21M8 | N/A | ZP-MC-A-21034 | N/A | N/A |
| | | ZP-MC-CG-29M5 | ZP-MC-CG-29M8 | N/A | N/A | ZP-MC-A-29100 | ZP-MC-A-29114 |
| | Surface Mount w/Automatic Cover | ZP-MC-CG-16M5 | ZP-MC-CG-16M8 | ZP-MC-A-16012 | N/A | N/A | N/A |
| | | ZP-MC-CG-21M5 | ZP-MC-CG-21M8 | N/A | ZP-MC-A-21034 | N/A | N/A |
| | | ZP-MC-CG-29M5 | ZP-MC-CG-29M8 | N/A | N/A | ZP-MC-A-29100 | ZP-MC-A-29114 |
| Bulkhead Base (Single Lever) | N/A | N/A | N/A | N/A | N/A | N/A | |
| Bulkhead w/Cover (Single Lever) | N/A | N/A | N/A | N/A | N/A | N/A | |
| Bulkhead w/Automatic Cover (Single Lever) | N/A | N/A | N/A | N/A | N/A | N/A | |
| Coupler (Single Lever) | ZP-MC-CG-16M5 | ZP-MC-CG-16M8 | ZP-MC-A-16012 | N/A | N/A | N/A | |
| Cover (Single Lever) | N/A | N/A | N/A | N/A | N/A | N/A | |
| Cover (2 Pegs) | N/A | N/A | N/A | N/A | N/A | N/A | |
| Double Lever / 4 Pegs | Top Entry Hood (4 Pegs) | ZP-MC-CG-16M5 | ZP-MC-CG-16M8 | ZP-MC-A-16012 | N/A | N/A | N/A |
| | | N/A | ZP-MC-CG-21M8 | N/A | ZP-MC-A-21034 | N/A | N/A |
| | | N/A | ZP-MC-CG-29M8 | N/A | N/A | ZP-MC-A-29100 | ZP-MC-A-29114 |
| | Top Double Entry Hood (4 Pegs) | N/A | ZP-MC-CG-13M8 | ZP-MC-A-13012**** | N/A | N/A | N/A |
| | | ZP-MC-CG-16M5 | ZP-MC-CG-16M8 | ZP-MC-A-16012 | N/A | N/A | N/A |
| | | N/A | ZP-MC-CG-21M8 | N/A | ZP-MC-A-21034 | N/A | N/A |
| | Side Entry Hood (4 Pegs) | N/A | ZP-MC-CG-29M8 | N/A | N/A | ZP-MC-A-29100 | ZP-MC-A-29114 |
| | | ZP-MC-CG-16M5 | ZP-MC-CG-16M8 | ZP-MC-A-16012 | N/A | N/A | N/A |
| | | N/A | ZP-MC-CG-21M8 | N/A | ZP-MC-A-21034 | N/A | N/A |
| | Surface Mount Base (4 Pegs) | N/A | ZP-MC-CG-29M8 | N/A | N/A | ZP-MC-A-29100 | ZP-MC-A-29114 |
| | | ZP-MC-CG-16M5 | ZP-MC-CG-16M8 | ZP-MC-A-16012 | N/A | N/A | N/A |
| | | N/A | ZP-MC-CG-21M8 | N/A | ZP-MC-A-21034 | N/A | N/A |
| | Bulkhead Base (Double Lever) | N/A | ZP-MC-CG-29M8 | N/A | N/A | ZP-MC-A-29100 | ZP-MC-A-29114 |
| | | N/A | N/A | N/A | N/A | N/A | N/A |
| | | N/A | ZP-MC-CG-16M8 | N/A | N/A | N/A | N/A |
| Coupler (Double Lever) | ZP-MC-CG-16M5 | ZP-MC-CG-16M8 | ZP-MC-A-16012 | N/A | N/A | N/A | |
| | N/A | ZP-MC-CG-21M8 | N/A | ZP-MC-A-21034 | N/A | N/A | |
| Cover (Double Lever) | N/A | N/A | N/A | N/A | N/A | N/A | |
| Cover (4 Pegs) | N/A | N/A | N/A | N/A | N/A | N/A | |

** To convert to NPT, select a Pg to NPT adapter.

*** Accessories pricing and details can be found in the Accessories section.

**** There are 2 openings per hood.



STD Series Multi-Wire Connectors, Size 16B



Company Information

Systems Overview

Programmable Controllers

Field I/O

Software

C-more & other HMI

Drives

Soft Starters

Motors & Gearbox

Steppers/Servos

Motor Controls

Proximity Sensors

Photo Sensors

Limit Switches

Encoders

Current Sensors

Pressure Sensors

Temperature Sensors

Pushbuttons/Lights

Process

Relays/Timers

Comm.

Terminal Blocks & Wiring

Power

Circuit Protection

Enclosures

Tools

Pneumatics

Safety

Appendix

Product Index

Part # Index

| Inserts | | | | | | | |
|-------------|---------------------|------------------|------------------|-------------------|-------------------|-------------------|-----------------|
| Insert Type | No. of Poles | 6+PE | | 16+PE | | 40+PE | 72+PE |
| | Rated Voltage AC/DC | 600 Volts | | 600 Volts | | 600 Volts | 600 Volts |
| | Max. Rated Current | 35 Amps | | 16 Amps | | 10 Amps | 10 Amps |
| | Termination Type | Screw Terminals | | Screw Terminals | Crimp Contacts* | Crimp Contacts* | Crimp Contacts* |
| Male | Part No. | ZP-MC16B-1-MS006 | ZP-MC16B-1-MS016 | ZP-MC16B-1-MC016 | ZP-MC16B-1-MC040 | ZP-MC16B-1-MC072 | |
| | Price | <--> | <--> | <--> | <--> | <--> | |
| | Contact Size | N/A | N/A | ZP-MC-CC-M16A-XX* | ZP-MC-CC-M10-XX* | ZP-MC-CC-M10A-XX* | |
| | Weight (lb.) | 0.174 | 0.180 | 0.123 | 0.125 | 0.125 | |
| Female | Part No. | ZP-MC16B-1-FS006 | ZP-MC16B-1-FS016 | ZP-MC16B-1-FC016 | ZP-MC16B-1-FC040 | ZP-MC16B-1-FC072 | |
| | Price | <--> | <--> | <--> | <--> | <--> | |
| | Contact Size | N/A | N/A | ZP-MC-CC-F16A-XX* | ZP-MC-CC-F10A-XX* | ZP-MC-CC-F10A-XX* | |
| | Weight (lb.) | 0.185 | 0.183 | 0.125 | 0.138 | 0.136 | |

*Crimp contacts must be purchased separately. The XX represents wire AWG. See Accessories section for complete part numbers.

| Hoods, Bases, Couplers and Covers | | | | | | Accessories*** |
|-----------------------------------|---|---------------------|--------------------|-------|----------------|-------------------|
| Housing Component | | Threading Opening** | Part No. | Price | Weight | Plugs with Gasket |
| Single Lever / 2 Pegs | Top Entry Hood (2 Pegs) | Pg 21 | ZP-MC16B-2-STE21M | <--> | 0.286 | ZP-MC-PLG-21M8 |
| | | Pg 21 HC | ZP-MC16B-2-STE21ML | <--> | 0.493 | ZP-MC-PLG-21M8 |
| | | Pg 29 HC | ZP-MC16B-2-STE29ML | <--> | 0.482 | ZP-MC-PLG-29M8 |
| | Side Entry Hood (2 Pegs) | Pg 21 | ZP-MC16B-2-SSE21M | <--> | 0.337 | ZP-MC-PLG-21M8 |
| | | Pg 21 HC | ZP-MC16B-2-SSE21ML | <--> | 0.419 | ZP-MC-PLG-21M8 |
| | | Pg 29 HC | ZP-MC16B-2-SSE29ML | <--> | 0.489 | ZP-MC-PLG-29M8 |
| | Surface Mount Base | Pg 21x2 | ZP-MC16B-2-SSM21M | <--> | 0.628 | ZP-MC-PLG-21M8 |
| | | Pg 21x2 HC | ZP-MC16B-2-SSM21ML | <--> | 0.776 | ZP-MC-PLG-21M8 |
| | | Pg 29x2 HC | ZP-MC16B-2-SSM29ML | <--> | 0.758 | ZP-MC-PLG-29M8 |
| | Surface Mount w/Cover | Pg 21x2 | ZP-MC16B-2-SSM21C | <--> | 0.811 | ZP-MC-PLG-21M8 |
| | | Pg 21x2 HC | ZP-MC16B-2-SSM21CL | <--> | 1.029 | ZP-MC-PLG-21M8 |
| | | Pg 29x2 HC | ZP-MC16B-2-SSM29CL | <--> | 0.928 | ZP-MC-PLG-29M8 |
| | Surface Mount w/Automatic Cover | Pg 21x2 | ZP-MC16B-2-SSM21CA | <--> | 0.836 | ZP-MC-PLG-21M8 |
| | | Pg 21x2 HC | ZP-MC16B-2-SM21CAL | <--> | 1.175 | ZP-MC-PLG-21M8 |
| | | Pg 29x2 HC | ZP-MC16B-2-SM29CAL | <--> | 1.157 | ZP-MC-PLG-29M8 |
| | Bulkhead Base (Single Lever) | N/A | ZP-MC16B-2-SBHM | <--> | 0.262 | N/A |
| | Bulkhead w/Cover (Single Lever) | N/A | ZP-MC16B-2-SBHC | <--> | 0.448 | N/A |
| | Bulkhead w/Automatic Cover (Single Lever) | N/A | ZP-MC16B-2-SBHCA | <--> | 0.613 | N/A |
| Coupler (2 Pegs) | Pg 21 | ZP-MC16B-2-SCP21M | <--> | 0.410 | ZP-MC-PLG-21M8 | |
| Cover (Single Lever) | N/A | ZP-MC16B-2-SCVLM | <--> | 0.224 | N/A | |
| Cover (2 Pegs) | N/A | ZP-MC16B-2-SCVPM | <--> | 0.119 | N/A | |
| Double Lever / 4 Pegs | Top Entry Hood (4 Pegs) | Pg 21 | ZP-MC16B-2-DTE21M | <--> | 0.284 | ZP-MC-PLG-21M8 |
| | | Pg 21 HC | ZP-MC16B-2-DTE21ML | <--> | 0.493 | ZP-MC-PLG-21M8 |
| | | Pg 29 HC | ZP-MC16B-2-DTE29ML | <--> | 0.474 | ZP-MC-PLG-29M8 |
| | Top Double Entry Hood (4 Pegs) | Pg 16x2 HC | ZP-MC16B-2-DTE16M2 | <--> | 0.560 | ZP-MC-PLG-16M8 |
| | | Pg 21x2 HC | ZP-MC16B-2-DTE21M2 | <--> | 0.547 | ZP-MC-PLG-21M8 |
| | Side Entry Hood (4 Pegs) | Pg 21 | ZP-MC16B-2-DSE21M | <--> | 0.324 | ZP-MC-PLG-21M8 |
| | | Pg 21 HC | ZP-MC16B-2-DSE21ML | <--> | 0.513 | ZP-MC-PLG-21M8 |
| | | Pg 29 HC | ZP-MC16B-2-DSE29ML | <--> | 0.513 | ZP-MC-PLG-29M8 |
| | Surface Mount Base | Pg 21x2 | ZP-MC16B-2-DSM21M | <--> | 0.674 | ZP-MC-PLG-21M8 |
| | | Pg 21x2 HC | ZP-MC16B-2-DSM21ML | <--> | 0.835 | ZP-MC-PLG-21M8 |
| | | Pg 29x2 HC | ZP-MC16B-2-DSM29ML | <--> | 0.809 | ZP-MC-PLG-29M8 |
| | Bulkhead Base (Double Lever) | N/A | ZP-MC16B-2-DBHM | <--> | 0.295 | N/A |
| | Coupler (Double Lever) | Pg 21 | ZP-MC16B-2-DCP21M | <--> | 0.445 | ZP-MC-PLG-21M8 |
| | | Pg 21 HC | ZP-MC16B-2-DCP21ML | <--> | 0.668 | ZP-MC-PLG-21M8 |
| | | Pg 29 HC | ZP-MC16B-2-DCP29ML | <--> | 0.681 | ZP-MC-PLG-29M8 |
| | Cover (Double Lever) | N/A | ZP-MC16B-2-DCVLM | <--> | 0.271 | N/A |
| | Cover (4 Peg) | N/A | ZP-MC16B-2-DCVPM | <--> | 0.116 | N/A |

HC = High Construction

** To convert to NPT, select a Pg to NPT adapter.

*** Accessories pricing and details can be found in the Accessories section.



STD Series Multi-Wire Connectors, Size 16B

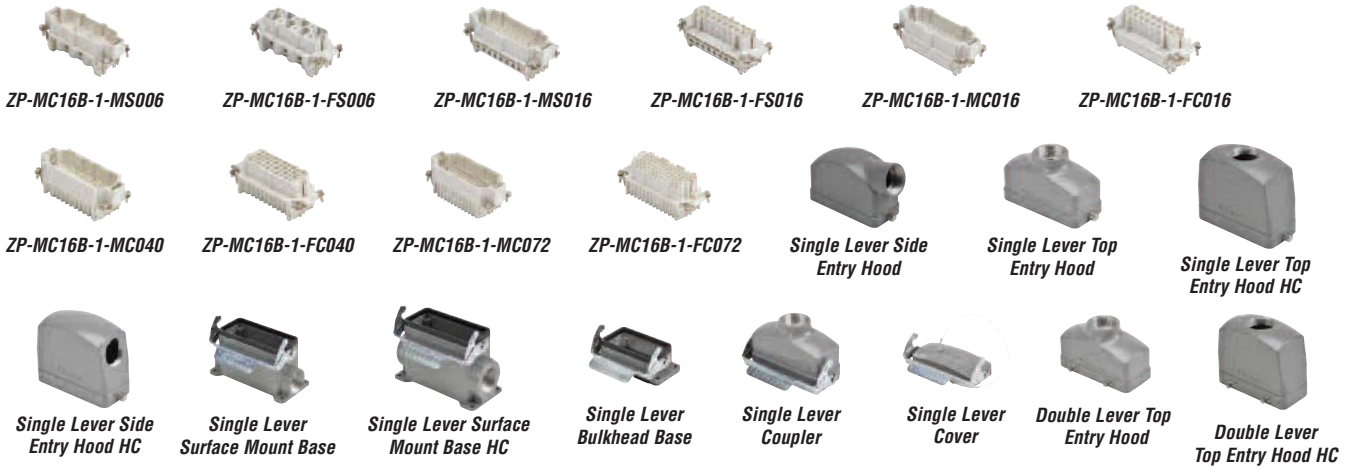

Accessories Continued***

| Housing Component | | IP66 Cable Glands | IP68 Cable Glands | Pg to NPT Adapter | | | |
|-----------------------|---|-------------------|-------------------|-------------------|---------------|---------------|-----------------|
| | | | | Pg 16 to 1/2" | Pg 21 to 3/4" | Pg 29 to 1" | Pg 29 to 1 1/4" |
| Single Lever / 2 Pegs | Top Entry Hood (2 Pegs) | ZP-MC-CG-21M5 | ZP-MC-CG-21M8 | N/A | ZP-MC-A-21034 | N/A | N/A |
| | | N/A | ZP-MC-CG-21M8 | N/A | ZP-MC-A-21034 | N/A | N/A |
| | | N/A | ZP-MC-CG-29M8 | N/A | N/A | ZP-MC-A-29100 | ZP-MC-A-29114 |
| | Side Entry Hood (2 Pegs) | ZP-MC-CG-21M5 | ZP-MC-CG-21M8 | N/A | ZP-MC-A-21034 | N/A | N/A |
| | | N/A | ZP-MC-CG-21M8 | N/A | ZP-MC-A-21034 | N/A | N/A |
| | | N/A | ZP-MC-CG-29M8 | N/A | N/A | ZP-MC-A-29100 | ZP-MC-A-29114 |
| | Surface Mount Base | ZP-MC-CG-21M5 | ZP-MC-CG-21M8 | N/A | ZP-MC-A-21034 | N/A | N/A |
| | | ZP-MC-CG-21M5 | ZP-MC-CG-21M8 | N/A | ZP-MC-A-21034 | N/A | N/A |
| | | ZP-MC-CG-29M5 | ZP-MC-CG-29M8 | N/A | N/A | ZP-MC-A-29100 | ZP-MC-A-29114 |
| | Surface Mount w/Cover | ZP-MC-CG-21M5 | ZP-MC-CG-21M8 | N/A | ZP-MC-A-21034 | N/A | N/A |
| | | ZP-MC-CG-21M5 | ZP-MC-CG-21M8 | N/A | ZP-MC-A-21034 | N/A | N/A |
| | | ZP-MC-CG-29M5 | ZP-MC-CG-29M8 | N/A | N/A | ZP-MC-A-29100 | ZP-MC-A-29114 |
| | Surface Mount w/Automatic Cover | ZP-MC-CG-21M5 | ZP-MC-CG-21M8 | N/A | ZP-MC-A-21034 | N/A | N/A |
| | | ZP-MC-CG-21M5 | ZP-MC-CG-21M8 | N/A | ZP-MC-A-21034 | N/A | N/A |
| | | ZP-MC-CG-29M5 | ZP-MC-CG-29M8 | N/A | N/A | ZP-MC-A-29100 | ZP-MC-A-29114 |
| | Bulkhead Base (Single Lever) | N/A | N/A | N/A | N/A | N/A | N/A |
| | Bulkhead w/Cover (Single Lever) | N/A | N/A | N/A | N/A | N/A | N/A |
| | Bulkhead w/Automatic Cover (Single Lever) | N/A | N/A | N/A | N/A | N/A | N/A |
| Coupler (2 Pegs) | ZP-MC-CG-21M5 | ZP-MC-CG-21M8 | N/A | ZP-MC-A-21034 | N/A | N/A | |
| Cover (Single Lever) | N/A | N/A | N/A | N/A | N/A | N/A | |
| Cover (2 Pegs) | N/A | N/A | N/A | N/A | N/A | N/A | |
| Double Lever / 4 Pegs | Top Entry Hood (4 Pegs) | ZP-MC-CG-21M5 | ZP-MC-CG-21M8 | N/A | ZP-MC-A-21034 | N/A | N/A |
| | | N/A | ZP-MC-CG-21M8 | N/A | ZP-MC-A-21034 | N/A | N/A |
| | | N/A | ZP-MC-CG-29M8 | N/A | N/A | ZP-MC-A-29100 | ZP-MC-A-29114 |
| | Top Double Entry Hood (4 Pegs) | N/A | ZP-MC-CG-16M8 | ZP-MC-A-16012 | N/A | N/A | N/A |
| | | N/A | ZP-MC-CG-21M8 | N/A | ZP-MC-A-21034 | N/A | N/A |
| | | ZP-MC-CG-21M5 | ZP-MC-CG-21M8 | N/A | ZP-MC-A-21034 | N/A | N/A |
| | Side Entry Hood (4 Pegs) | N/A | ZP-MC-CG-21M8 | N/A | ZP-MC-A-21034 | N/A | N/A |
| | | N/A | ZP-MC-CG-21M8 | N/A | ZP-MC-A-21034 | N/A | N/A |
| | | N/A | ZP-MC-CG-29M8 | N/A | N/A | ZP-MC-A-29100 | ZP-MC-A-29114 |
| | Surface Mount Base | ZP-MC-CG-21M5 | ZP-MC-CG-21M8 | N/A | ZP-MC-A-21034 | N/A | N/A |
| | | N/A | ZP-MC-CG-21M8 | N/A | ZP-MC-A-21034 | N/A | N/A |
| | | N/A | ZP-MC-CG-29M8 | N/A | N/A | ZP-MC-A-29100 | ZP-MC-A-29114 |
| | Bulkhead Base (Double Lever) | N/A | N/A | N/A | N/A | N/A | N/A |
| | Coupler (Double Lever) | ZP-MC-CG-21M5 | ZP-MC-CG-21M8 | N/A | ZP-MC-A-21034 | N/A | N/A |
| | | N/A | ZP-MC-CG-21M8 | N/A | ZP-MC-A-21034 | N/A | N/A |
| | | N/A | ZP-MC-CG-29M8 | N/A | N/A | ZP-MC-A-29100 | ZP-MC-A-29114 |
| | Cover (Double Lever) | N/A | N/A | N/A | N/A | N/A | N/A |
| | Cover (4 Pegs) | N/A | N/A | N/A | N/A | N/A | N/A |

*** Accessories pricing and details can be found in the Accessories section.



STD Series Multi-Wire Connectors, Size 24B



Company Information

Systems Overview

Programmable Controllers

Field I/O

Software

C-more & other HMI

Drives

Soft Starters

Motors & Gearbox

Steppers/Servos

Motor Controls

Proximity Sensors

Photo Sensors

Limit Switches

Encoders

Current Sensors

Pressure Sensors

Temperature Sensors

Pushbuttons/Lights

Process

Relays/Timers

Comm.

Terminal Blocks & Wiring

Power

Circuit Protection

Enclosures

Tools

Pneumatics

Safety

Appendix

Product Index

Part # Index

| Inserts | | | | | | | |
|------------------|---------------------|---------------------------|------------------|-------------------|-------------------|-------------------|-----------|
| Insert Type | No. of Poles | 8+4+PE | | 24+PE | | 64+PE | 108+PE |
| | Rated Voltage AC/DC | 600 Volts | | 600 Volts | | 600 Volts | 600 Volts |
| | Max. Rated Current | 4 x 80 Amps / 8 x 16 Amps | | 16 Amps | | 10 Amps | 10 Amps |
| Termination Type | Screw Terminals | | Screw Terminals | Crimp Contacts* | Crimp Contacts* | Crimp Contacts* | |
| Male | Part No. | ZP-MC24B-1-MS048 | ZP-MC24B-1-MS024 | ZP-MC24B-1-MC024 | ZP-MC24B-1-MC064 | ZP-MC24B-1-MC108 | |
| | Price | <---> | <---> | <---> | <---> | <---> | |
| | Contact Size | N/A | N/A | ZP-MC-CC-M16A-XX* | ZP-MC-CC-M10A-XX* | ZP-MC-CC-M10A-XX* | |
| | Weight (lb.) | 0.321 | 0.240 | 0.152 | 0.163 | 0.158 | |
| Female | Part No. | ZP-MC24B-1-FS048 | ZP-MC24B-1-FS024 | ZP-MC24B-1-FC024 | ZP-MC24B-1-FC064 | ZP-MC24B-1-FC108 | |
| | Price | <---> | <---> | <---> | <---> | <---> | |
| | Contact Size | N/A | N/A | ZP-MC-CC-M16A-XX* | ZP-MC-CC-M10A-XX* | ZP-MC-CC-M10A-XX* | |
| | Weight (lb.) | 0.315 | 0.253 | 0.163 | 0.180 | 0.174 | |

* Crimp contacts must be purchased separately. The XX represents wire AWG. See Accessories section for complete part numbers.

| Hoods, Bases, Couplers and Covers | | | | | Accessories*** | |
|-----------------------------------|--------------------------------------|---------------------|--------------------|-------|----------------|-------------------|
| Housing Component | | Threading Opening** | Part No. | Price | Weight | Plugs with Gasket |
| Single Lever / 2 Pegs | Top Entry Hood (Single Lever) | Pg 21 | ZP-MC24B-2-STE21M | <---> | 0.432 | ZP-MC-PLG-21M8 |
| | | Pg 21 HC | ZP-MC24B-2-STE21ML | <---> | 0.599 | ZP-MC-PLG-21M8 |
| | | Pg 29 HC | ZP-MC24B-2-STE29ML | <---> | 0.601 | ZP-MC-PLG-29M8 |
| | Side Entry Hood (Single Lever) | Pg 21 | ZP-MC24B-2-SSE21M | <---> | 0.434 | ZP-MC-PLG-21M8 |
| | | Pg 21 HC | ZP-MC24B-2-SSE21ML | <---> | 0.599 | ZP-MC-PLG-21M8 |
| | | Pg 29 HC | ZP-MC24B-2-SSE29ML | <---> | 0.573 | ZP-MC-PLG-29M8 |
| | Surface Mount Base (2 Peg) | Pg 21x2 | ZP-MC24B-2-SSM21M | <---> | 0.709 | ZP-MC-PLG-21M8 |
| | | Pg 21x2 HC | ZP-MC24B-2-SSM21ML | <---> | 0.919 | ZP-MC-PLG-21M8 |
| | | Pg 29x2 HC | ZP-MC24B-2-SSM29ML | <---> | 0.901 | ZP-MC-PLG-29M8 |
| | Surface Mount (Single Lever w/Cover) | Pg 21x2 | ZP-MC24B-2-SSM21C | <---> | 0.924 | ZP-MC-PLG-21M8 |
| | | Pg 21x2 HC | ZP-MC24B-2-SSM21CL | <---> | 1.204 | ZP-MC-PLG-21M8 |
| | | Pg 29x2 HC | ZP-MC24B-2-SSM29CL | <---> | 1.118 | ZP-MC-PLG-29M8 |
| | Surface Mount w/Automatic Cover | Pg 21x2 | ZP-MC24B-2-SSM21CA | <---> | 0.972 | ZP-MC-PLG-21M8 |
| | | Pg 21x2 HC | ZP-MC24B-2-SM21CAL | <---> | 1.358 | ZP-MC-PLG-21M8 |
| | | Pg 29x2 HC | ZP-MC24B-2-SM29CAL | <---> | 1.354 | ZP-MC-PLG-29M8 |
| | Bulkhead Base (Single Lever) | N/A | ZP-MC24B-2-SBHM | <---> | 0.310 | N/A |
| | Bulkhead w/Cover | N/A | ZP-MC24B-2-SBHC | <---> | 0.525 | N/A |
| | Bulkhead w/Automatic Cover | N/A | ZP-MC24B-2-SBHCA | <---> | 0.697 | N/A |
| Coupler (2 Peg) | Pg 21 | ZP-MC24B-2-SCP21M | <---> | 0.566 | ZP-MC-PLG-21M8 | |
| Cover (Single Lever) | N/A | ZP-MC24B-2-SCVLM | <---> | 0.255 | N/A | |
| Cover (2 Peg) | N/A | ZP-MC24B-2-SCVPM | <---> | 0.157 | N/A | |
| Double Lever / 4 Peg | Top Entry Hood (Double Lever) | Pg 21 | ZP-MC24B-2-DTE21M | <---> | 0.447 | ZP-MC-PLG-21M8 |
| | | Pg 29 | ZP-MC24B-2-DTE29M | <---> | 0.385 | ZP-MC-PLG-29M8 |
| | | Pg 21 HC | ZP-MC24B-2-DTE21ML | <---> | 0.612 | ZP-MC-PLG-21M8 |
| | Top Double Entry Hood (4 Peg) | Pg 29 HC | ZP-MC24B-2-DTE29ML | <---> | 0.560 | ZP-MC-PLG-29M8 |
| | | Pg 21x2 | ZP-MC24B-2-DTE21M2 | <---> | 0.664 | ZP-MC-PLG-21M8 |
| | | Pg 29x2 | ZP-MC24B-2-DTE29M2 | <---> | 0.648 | ZP-MC-PLG-29M8 |
| | Side Entry Hood (Double Lever) | Pg 21 | ZP-MC24B-2-DSE21M | <---> | 0.427 | ZP-MC-PLG-21MB |
| | | Pg 29 | ZP-MC24B-2-DSE29M | <---> | 0.388 | ZP-MC-PLG-29M8 |
| | | Pg 21 HC | ZP-MC24B-2-DSE21ML | <---> | 0.560 | ZP-MC-PLG-21M8 |
| | Surface Mount Base (4 Peg) | Pg 29 HC | ZP-MC24B-2-DSE29ML | <---> | 0.659 | ZP-MC-PLG-29M8 |
| | | Pg 21x2 | ZP-MC24B-2-DSM21M | <---> | 0.747 | ZP-MC-PLG-21M8 |
| | | Pg 21x2 HC | ZP-MC24B-2-DSM21ML | <---> | 0.930 | ZP-MC-PLG-21M8 |
| | Bulkhead Base (Double Lever) | Pg 29x2 HC | ZP-MC24B-2-DSM29ML | <---> | 0.901 | ZP-MC-PLG-29M8 |
| | | N/A | ZP-MC24B-2-DBHM | <---> | 0.343 | N/A |
| | | Pg 21 | ZP-MC24B-2-DCP21M | <---> | 0.599 | ZP-MC-PLG-21M8 |
| | Coupler (Double Lever) | Pg 21 HC | ZP-MC24B-2-DCP21ML | <---> | 0.813 | ZP-MC-PLG-21M8 |
| | | Pg 29 HC | ZP-MC24B-2-DCP29ML | <---> | 0.782 | ZP-MC-PLG-29M8 |
| | | N/A | ZP-MC24B-2-DCVLM | <---> | 0.291 | N/A |
| Cover (Double Lever) | N/A | ZP-MC24B-2-DCVPM | <---> | 0.152 | N/A | |
| Cover (4 Peg) | N/A | ZP-MC24B-2-DCVPM | <---> | 0.152 | N/A | |

HC = High Construction

** To convert to NPT, select a Pg to NPT adapter.

*** Accessories pricing and details can be found in the Accessories section.



STD Series Multi-Wire Connectors, Size 24B



Single Lever Top Entry Hood

Single Lever Top Entry Hood High Capacity

Single Lever Side Entry Hood

Single Lever Side Entry Hood High Capacity

Single Lever Surface Mount Base

| Accessories Continued*** | | | | | | |
|------------------------------|--------------------------------------|-------------------|-------------------|-------------------|---------------|-----------------|
| Housing Component | | IP66 Cable Glands | IP68 Cable Glands | Pg to NPT Adapter | | |
| | | | | Pg 21 to 3/4" | Pg 29 to 1" | Pg 29 to 1 1/4" |
| Single Lever / 2 Pegs | Top Entry Hood (Single Lever) | ZP-MC-CG-21M5 | ZP-MC-CG-21M8 | ZP-MC-A-21034 | N/A | N/A |
| | | N/A | ZP-MC-CG-21M8 | ZP-MC-A-21034 | N/A | N/A |
| | | N/A | ZP-MC-CG-29M8 | N/A | ZP-MC-A-29100 | ZP-MC-A-29114 |
| | Side Entry Hood (Single Lever) | ZP-MC-CG-21M5 | ZP-MC-CG-21M8 | ZP-MC-A-21034 | N/A | N/A |
| | | N/A | ZP-MC-CG-21M8 | ZP-MC-A-21034 | N/A | N/A |
| | | N/A | ZP-MC-CG-29M8 | N/A | ZP-MC-A-29100 | ZP-MC-A-29114 |
| | Surface Mount Base (2 Peg) | ZP-MC-CG-21M5 | ZP-MC-CG-21M8 | ZP-MC-A-21034 | N/A | N/A |
| | | ZP-MC-CG-21M5 | ZP-MC-CG-21M8 | ZP-MC-A-21034 | N/A | N/A |
| | | ZP-MC-CG-29M5 | ZP-MC-CG-29M8 | N/A | ZP-MC-A-29100 | ZP-MC-A-29114 |
| | Surface Mount (Single Lever w/Cover) | ZP-MC-CG-21M5 | ZP-MC-CG-21M8 | ZP-MC-A-21034 | N/A | N/A |
| | | ZP-MC-CG-21M5 | ZP-MC-CG-21M8 | ZP-MC-A-21034 | N/A | N/A |
| | | ZP-MC-CG-29M5 | ZP-MC-CG-29M8 | N/A | ZP-MC-A-29100 | ZP-MC-A-29114 |
| | Surface Mount w/Automatic Cover | ZP-MC-CG-21M5 | ZP-MC-CG-21M8 | ZP-MC-A-21034 | N/A | N/A |
| | | ZP-MC-CG-21M5 | ZP-MC-CG-21M8 | ZP-MC-A-21034 | N/A | N/A |
| | | ZP-MC-CG-29M5 | ZP-MC-CG-29M8 | N/A | ZP-MC-A-29100 | ZP-MC-A-29114 |
| Bulkhead Base (Single Lever) | N/A | N/A | N/A | N/A | N/A | |
| Bulkhead w/Cover | N/A | N/A | N/A | N/A | N/A | |
| Bulkhead w/Automatic Cover | N/A | N/A | N/A | N/A | N/A | |
| Coupler (2 Peg) | ZP-MC-CG-21M5 | ZP-MC-CG-21M8 | ZP-MC-A-21034 | N/A | N/A | |
| Cover (Single Lever) | N/A | N/A | N/A | N/A | N/A | |
| Cover (2 Peg) | N/A | N/A | N/A | N/A | N/A | |
| Double Lever / 4 Pegs | Top Entry Hood (Double Lever) | ZP-MC-CG-21M5 | ZP-MC-CG-21M8 | ZP-MC-A-21034 | N/A | N/A |
| | | ZP-MC-CG-29M5 | ZP-MC-CG-29M8 | N/A | ZP-MC-A-29100 | ZP-MC-A-29114 |
| | | N/A | ZP-MC-CG-21M8 | ZP-MC-A-21034 | N/A | N/A |
| | Top Double Entry Hood (4 Peg) | ZP-MC-CG-21M5 | ZP-MC-CG-21M8 | ZP-MC-A-21034 | N/A | N/A |
| | | ZP-MC-CG-29M5 | ZP-MC-CG-29M8 | N/A | ZP-MC-A-29100 | ZP-MC-A-29114 |
| | | ZP-MC-CG-21M5 | ZP-MC-CG-21M8 | ZP-MC-A-21034 | N/A | N/A |
| | Side Entry Hood (Double Lever) | ZP-MC-CG-29M5 | ZP-MC-CG-29M8 | N/A | ZP-MC-A-29100 | ZP-MC-A-29114 |
| | | N/A | ZP-MC-CG-21M8 | ZP-MC-A-21034 | N/A | N/A |
| | | N/A | ZP-MC-CG-29M8 | N/A | ZP-MC-A-29100 | ZP-MC-A-29114 |
| | Surface Mount Base (4 Peg) | ZP-MC-CG-21M5 | ZP-MC-CG-21M8 | ZP-MC-A-21034 | N/A | N/A |
| | | N/A | ZP-MC-CG-21M8 | ZP-MC-A-21034 | N/A | N/A |
| | | N/A | ZP-MC-CG-29M8 | N/A | ZP-MC-A-29100 | ZP-MC-A-29114 |
| | Bulkhead Base (Double Lever) | N/A | N/A | N/A | N/A | N/A |
| | Coupler (Double Lever) | ZP-MC-CG-21M5 | ZP-MC-CG-21M8 | ZP-MC-A-21034 | N/A | N/A |
| | | N/A | ZP-MC-CG-21M8 | ZP-MC-A-21034 | N/A | N/A |
| N/A | | ZP-MC-CG-29M8 | N/A | ZP-MC-A-29100 | ZP-MC-A-29114 | |
| Cover (Double Lever) | N/A | N/A | N/A | N/A | N/A | |
| Cover (4 Peg) | N/A | N/A | N/A | N/A | N/A | |



Note: See end of section for accessory photos.

*** Accessories pricing and details can be found in the Accessories section.



STD Series Multi-Wire Connectors, Size 32B



ZP-MC16B-1-MS016



ZP-MC16B-1-MS016-2



ZP-MC16B-1-MC016



ZP-MC16B-1-MC016-2



ZP-MC16B-1-MC072



ZP-MC16B-1-MC072-2



ZP-MC16B-1-FS016



ZP-MC16B-1-FS016-2



ZP-MC16B-1-FC016



ZP-MC16B-1-FC016-2



ZP-MC16B-1-FC072



ZP-MC16B-1-FC072-2

| Inserts | | | | | |
|-------------|-------------------------|------------------|--------------------|-------------------|--------------------|
| Insert Type | No. of Poles | 32+PE | | | |
| | Rated Voltage AC/DC | 600 Volts | | | |
| | Max. Rated Current | 16 Amps | | | |
| | Termination Type | Screw Terminals | | Crimp Contacts* | |
| | Pole Numbering Sequence | 1-16 | 17-32 | 1-16 | 17-32 |
| Male | Part No. | ZP-MC16B-1-MS016 | ZP-MC16B-1-MS016-2 | ZP-MC16B-1-MC016 | ZP-MC16B-1-MC016-2 |
| | Price | <---> | <---> | <---> | <---> |
| | Contact Size | N/A | N/A | ZP-MC-CC-M16A-XX* | |
| | Weight (lb.) | 0.180 | 0.181 | 0.123 | 0.126 |
| Female | Part No. | ZP-MC16B-1-FS016 | ZP-MC16B-1-FS016-2 | ZP-MC16B-1-FC016 | ZP-MC16B-1-FC016-2 |
| | Price | <---> | <---> | <---> | <---> |
| | Contact Size | N/A | N/A | ZP-MC-CC-F16A-XX* | |
| | Weight (lb.) | 0.183 | 0.185 | 0.125 | 0.130 |

*Crimp contacts must be purchased separately. The XX represents wire AWG. See Accessories section for complete part numbers.

** Each insert is 16 poles. 2 inserts are required per housing to make 32 poles.

| Hoods, Bases, Couplers and Covers | | | | | Accessories*** | |
|-----------------------------------|--------------------------------|---------------------|-------------------|-------|----------------|-------------------|
| Housing Component | | Threading Opening** | Part No. | Price | Weight | Plugs with Gasket |
| Single Lever / 2 Poles | Top Entry Hood (Single Lever) | Pg 36 | ZP-MC32B-2-STE36M | <---> | 0.822 | ZP-MC-PLG-36M8 |
| | Side Entry Hood (Single Lever) | Pg 36 | ZP-MC32B-2-SSE36M | <---> | 0.809 | ZP-MC-PLG-36M8 |
| | Surface Mount Base (2 Peg) | Pg 36x2 | ZP-MC32B-2-SSM36M | <---> | 1.446 | ZP-MC-PLG-36M8 |
| | Surface Mount w/Cover | Pg 36x2 | ZP-MC32B-2-SSM36C | <---> | 1.665 | ZP-MC-PLG-36M8 |
| | Bulkhead Base (Single Lever) | N/A | ZP-MC32B-2-SBHM | <---> | 0.503 | N/A |
| | Bulkhead w/Cover | N/A | ZP-MC32B-2-SBHC | <---> | 0.743 | N/A |
| | Coupler (2 Peg) | Pg 36 | ZP-MC32B-2-SCP36M | <---> | 1.058 | ZP-MC-PLG-36M8 |
| | Cover (Single Lever) | N/A | ZP-MC32B-2-SCVLM | <---> | 0.417 | N/A |
| | Cover (2 Peg) | N/A | ZP-MC32B-2-SCVPM | <---> | 0.183 | N/A |
| Double Lever / 4 Poles | Top Entry Hood (Double Lever) | Pg 36 | ZP-MC32B-2-DTE36M | <---> | 0.831 | ZP-MC-PLG-36M8 |
| | Side Entry Hood (Double Lever) | Pg 36 | ZP-MC32B-2-DSE36M | <---> | 0.849 | ZP-MC-PLG-36M8 |
| | Surface Mount Base (4 Peg) | Pg 36x2 | ZP-MC32B-2-DSM36M | <---> | 1.407 | ZP-MC-PLG-36M8 |
| | Bulkhead Base (Double Lever) | N/A | ZP-MC32B-2-DBHM | <---> | 0.549 | N/A |
| | Coupler (Double Lever) | Pg 36 | ZP-MC32B-2-DCP36M | <---> | 1.065 | ZP-MC-PLG-36M8 |
| | Cover (Double Lever) | N/A | ZP-MC32B-2-DCVLM | <---> | 0.426 | N/A |
| | Cover (4 Peg) | N/A | ZP-MC32B-2-DCVPM | <---> | 0.201 | N/A |

HC = High Construction

** To convert to NPT, select a Pg to NPT adapter.

*** Accessories pricing and details can be found in the Accessories section.



STD Series Multi-Wire Connectors, Size 32B



| Inserts Continued | | | |
|--------------------|--------------------------------|-------------------------|---------------------------|
| Insert Type | No. of Poles | 144+PE | |
| | Rated Voltage AC/DC | 600 Volts | |
| | Max. Rated Current | 10A | |
| | Termination Type | Crimp Contacts* | |
| | Pole Numbering Sequence | 1-16 | 17-32 |
| Male | Part No. | ZP-MC16B-1-MC072 | ZP-MC16B-1-MC072-2 |
| | Price | <---> | <---> |
| | Contact Size | ZP-MC-CC-M10-XX* | |
| | Weight (lb.) | 0.125 | 0.130 |
| Female | Part No. | ZP-MC16B-1-FC072 | ZP-MC16B-1-FC072-2 |
| | Price | <---> | <---> |
| | Contact Size | ZP-MC-CC-F10A-XX* | |
| | Weight (lb.) | 0.136 | 0.139 |

Note: See end of section for accessory photos.

*Crimp contacts must be purchased separately. The XX represents wire AWG. See Accessories section for complete part numbers.
 ** Each insert is 16 poles. 2 inserts are required per housing to make 32 poles.

| Accessories Continued*** | | | | |
|-------------------------------|---------------------------------------|-------------------|-------------------|-------------------|
| Housing Component | | IP66 Cable Glands | IP68 Cable Glands | Pg to NPT Adapter |
| | | | | Pg 36 to 1¼" |
| Single Lever / 2 Poles | Top Entry Hood (Single Lever) | ZP-MC-CG-36M5 | ZP-MC-CG-36M8 | ZP-MC-A-36114 |
| | Side Entry Hood (Single Lever) | ZP-MC-CG-36M5 | ZP-MC-CG-36M8 | ZP-MC-A-36114 |
| | Surface Mount Base (2 Peg) | ZP-MC-CG-36M5 | ZP-MC-CG-36M8 | ZP-MC-A-36114 |
| | Surface Mount w/Cover | ZP-MC-CG-36M5 | ZP-MC-CG-36M8 | ZP-MC-A-36114 |
| | Bulkhead Base (Single Lever) | N/A | N/A | N/A |
| | Bulkhead w/Cover | N/A | N/A | N/A |
| | Coupler (2 Peg) | ZP-MC-CG-36M5 | ZP-MC-CG-36M8 | ZP-MC-A-36114 |
| | Cover (Single Lever) | N/A | N/A | N/A |
| | Cover (2 Peg) | N/A | N/A | N/A |
| Double Lever / 4 Poles | Top Entry Hood (Double Lever) | ZP-MC-CG-36M5 | ZP-MC-CG-36M8 | ZP-MC-A-36114 |
| | Side Entry Hood (Double Lever) | ZP-MC-CG-36M5 | ZP-MC-CG-36M8 | ZP-MC-A-36114 |
| | Surface Mount Base (4 Peg) | ZP-MC-CG-36M5 | ZP-MC-CG-36M8 | ZP-MC-A-36114 |
| | Bulkhead Base (Double Lever) | N/A | N/A | N/A |
| | Coupler (Double Lever) | ZP-MC-CG-36M5 | ZP-MC-CG-36M8 | ZP-MC-A-36114 |
| | Cover (Double Lever) | N/A | N/A | N/A |
| | Cover (4 Peg) | N/A | N/A | N/A |

*** Accessories pricing and details can be found in the Accessories section.

ZIP^{port} STD Series Multi-Wire Connectors

Electrical Engineering Data - Load Diagrams

Derating diagram According to IEC/EN 60512

These diagrams illustrate the maximum current carrying capacity of components. The illustration follows a curve which shows the current in relation to ambient temperature.

Current carrying capacity is limited by the thermal characteristics of contacts and insulating elements which have an upper temperature limit that should not be exceeded.

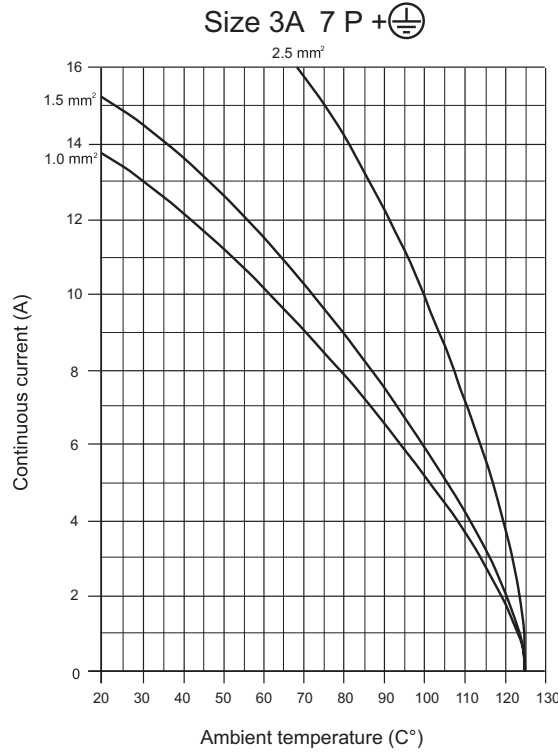
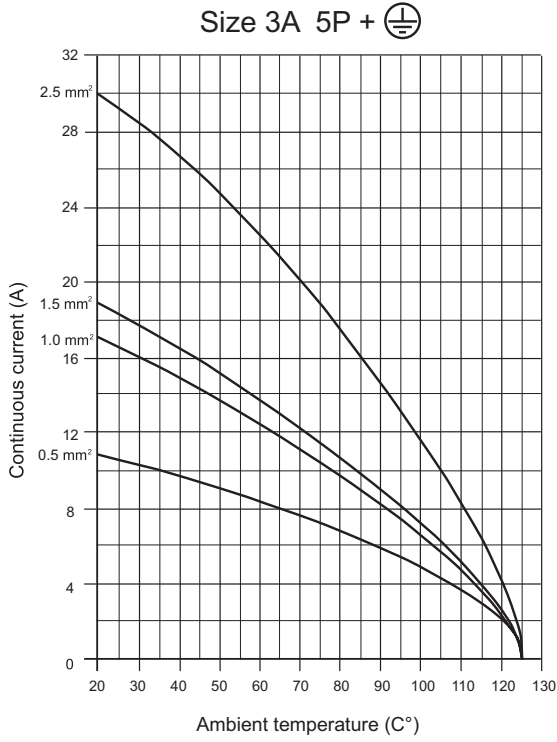
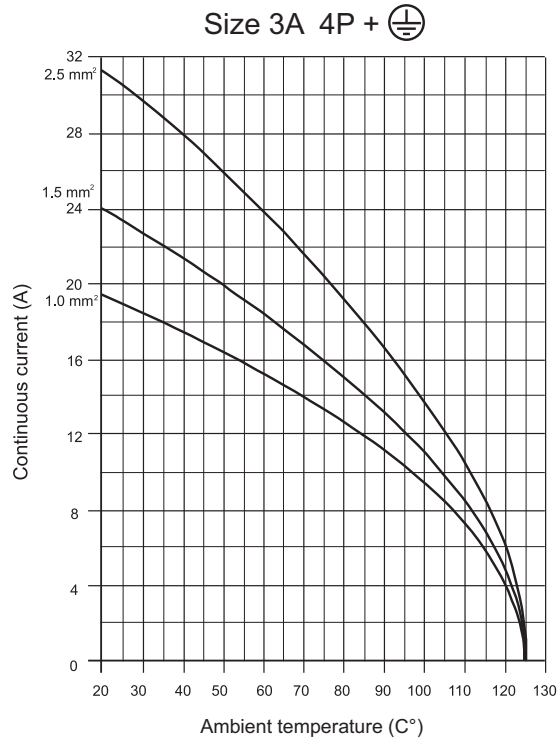
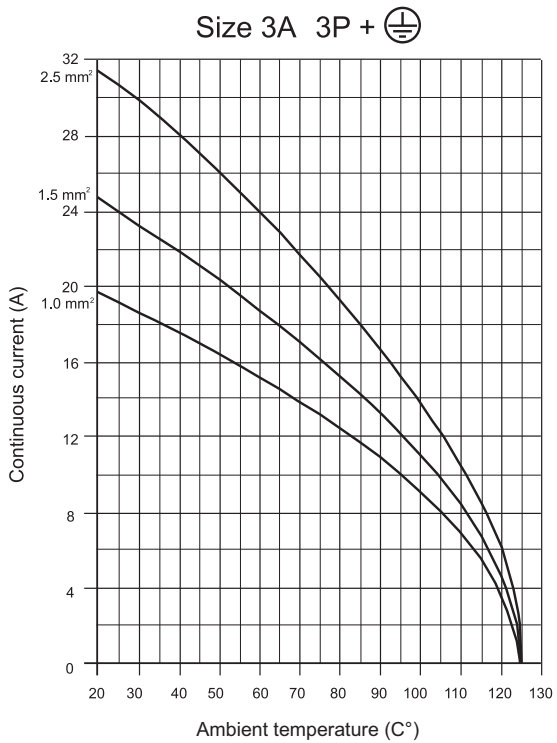



STD Series Multi-Wire Connectors

Electrical Engineering Data - Load Diagrams

Size 3A 12 P + 

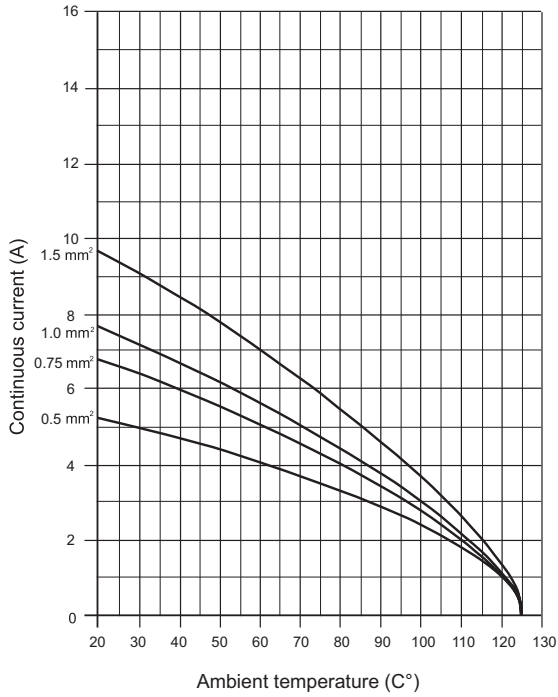

Electrical Engineering Data - Load Diagrams

Size 10A 10P +

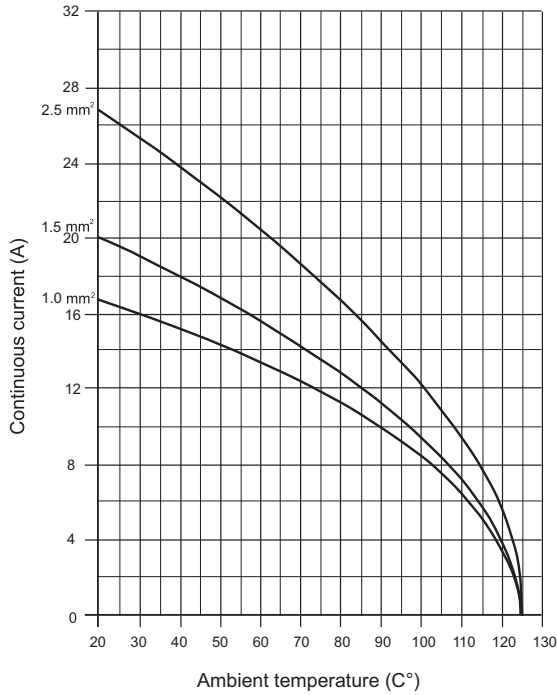

Size 10A 15P +

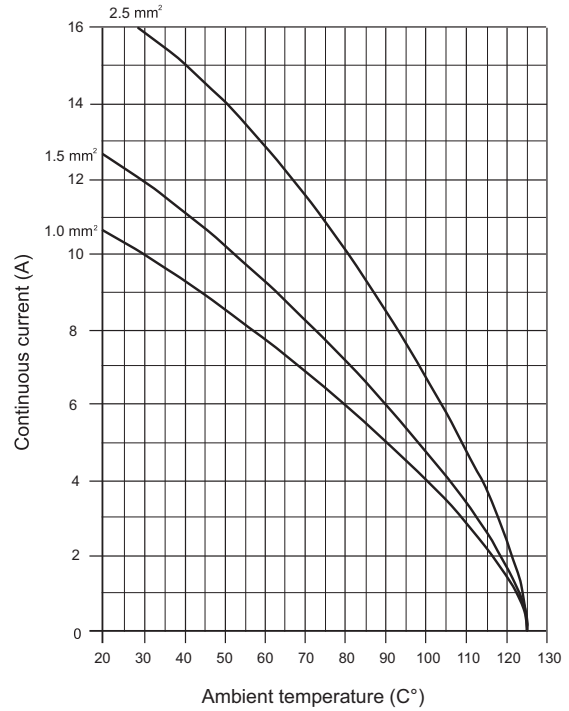

Size 16A 16P +

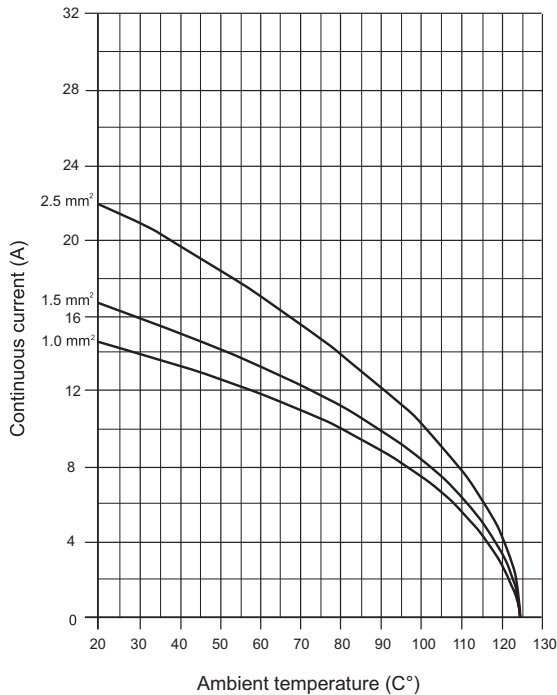

Size 16A 25P +

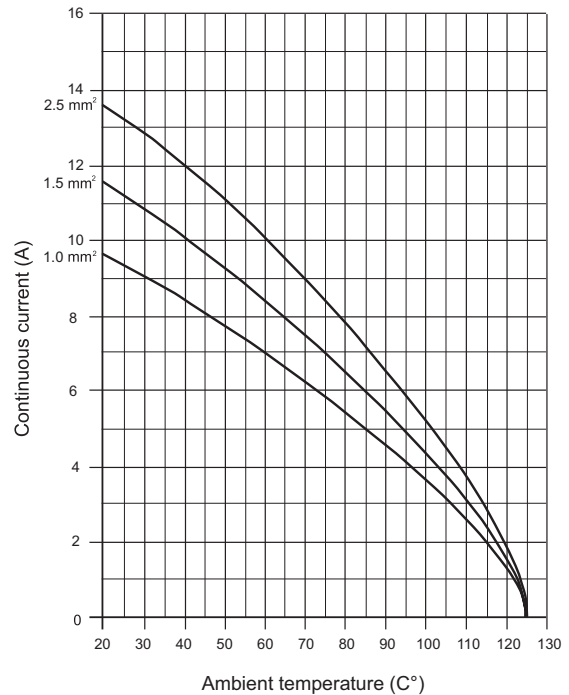



STD Series Multi-Wire Connectors

Electrical Engineering Data - Load Diagrams

Size 6B 6P +

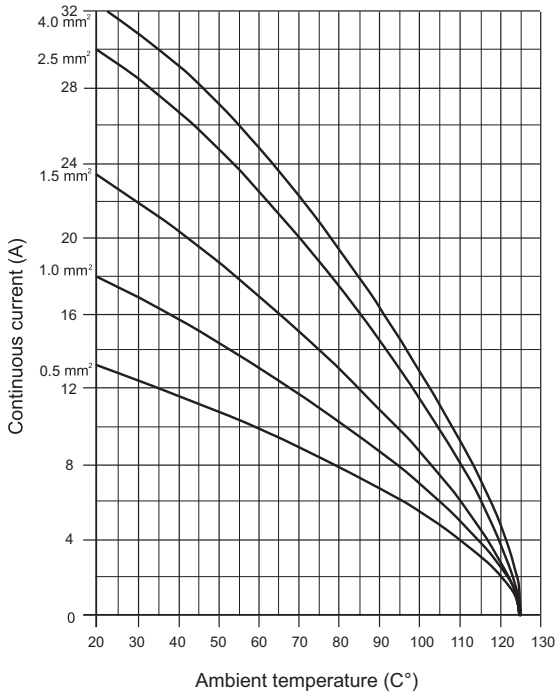

Size 6B 24P +

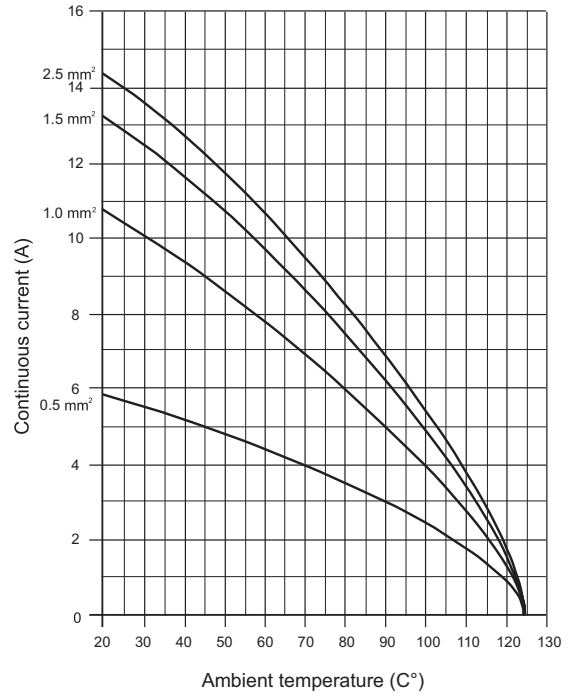

Size 10B 10P +

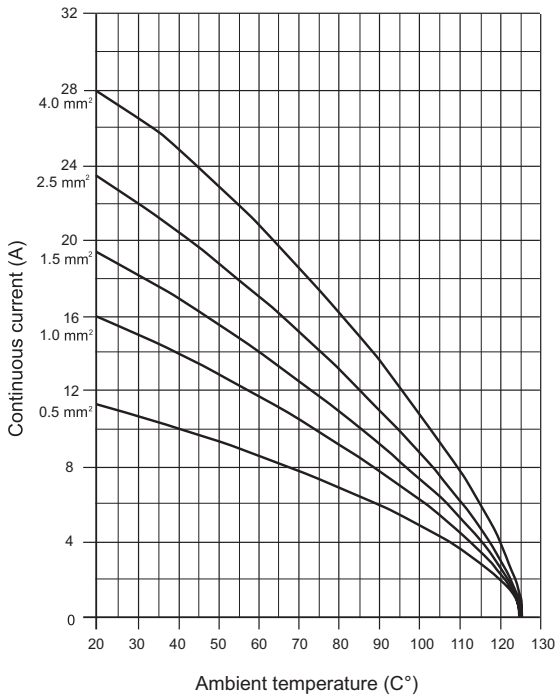

Size 10B 42P +

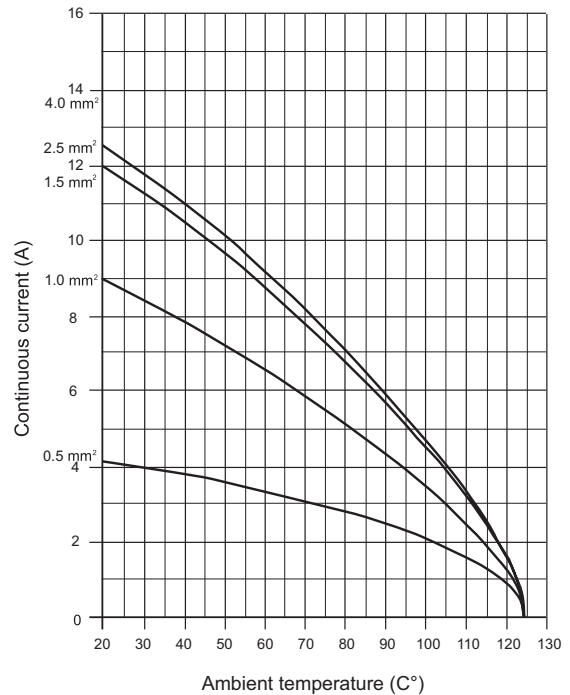

ZIPport[®] STD Series Multi-Wire Connectors

Electrical Engineering Data - Load Diagrams

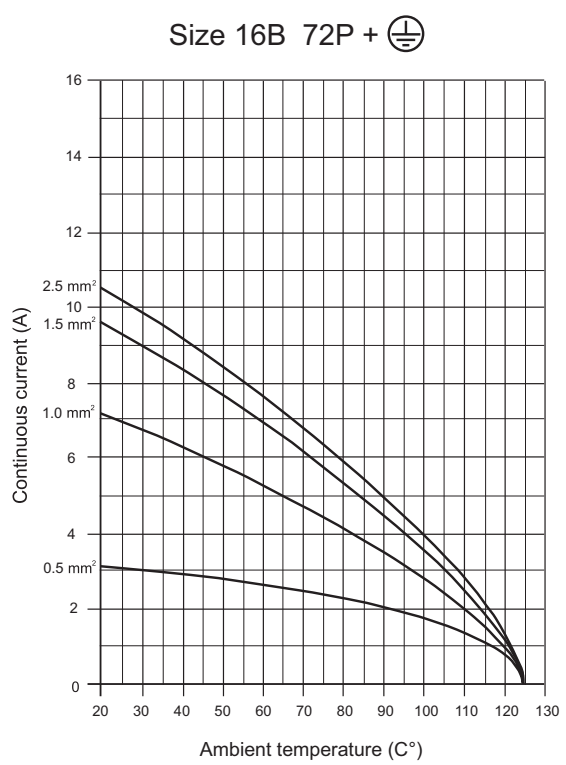
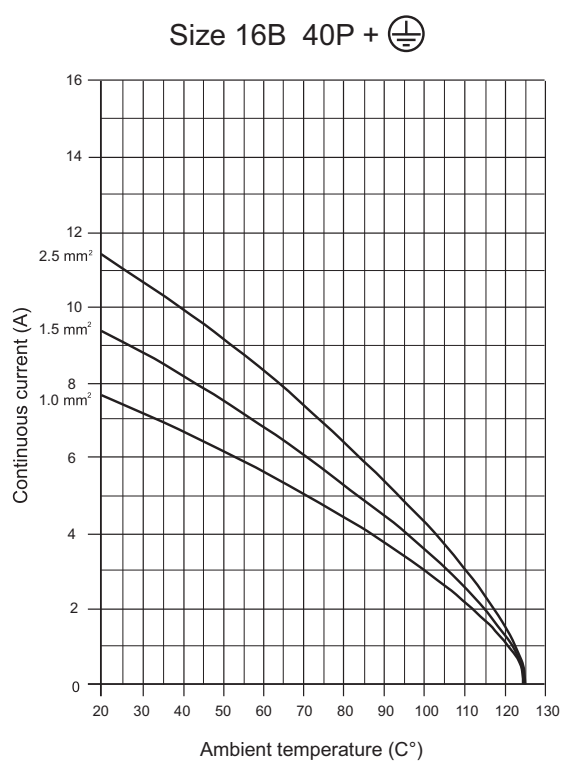
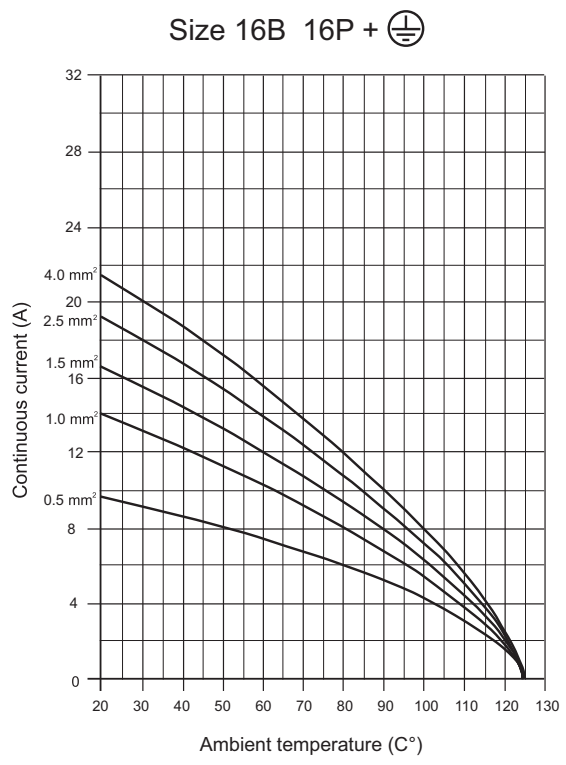
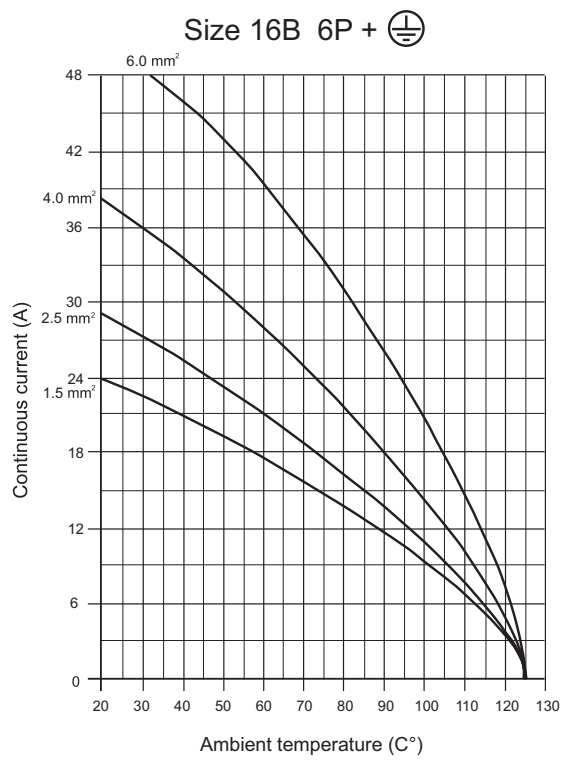



STD Series Multi-Wire Connectors

Electrical Engineering Data - Load Diagrams

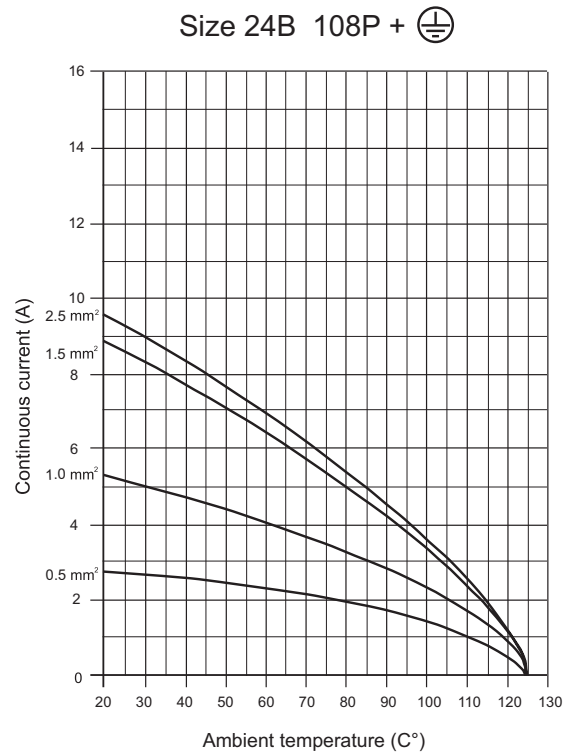
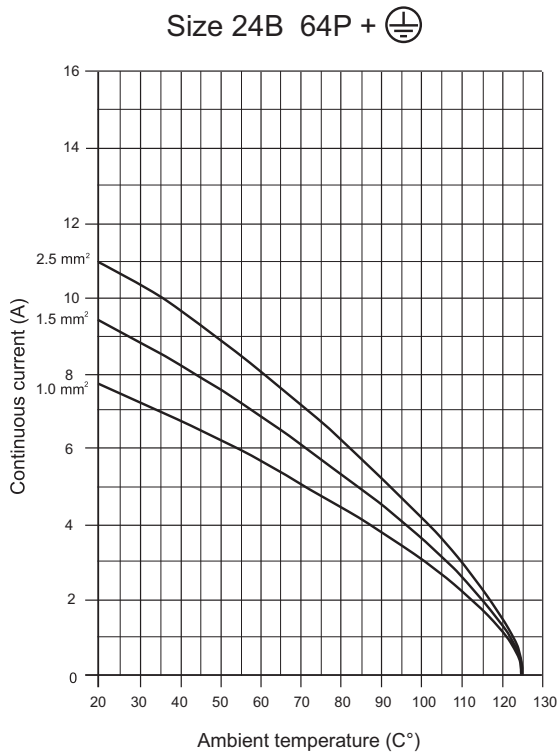
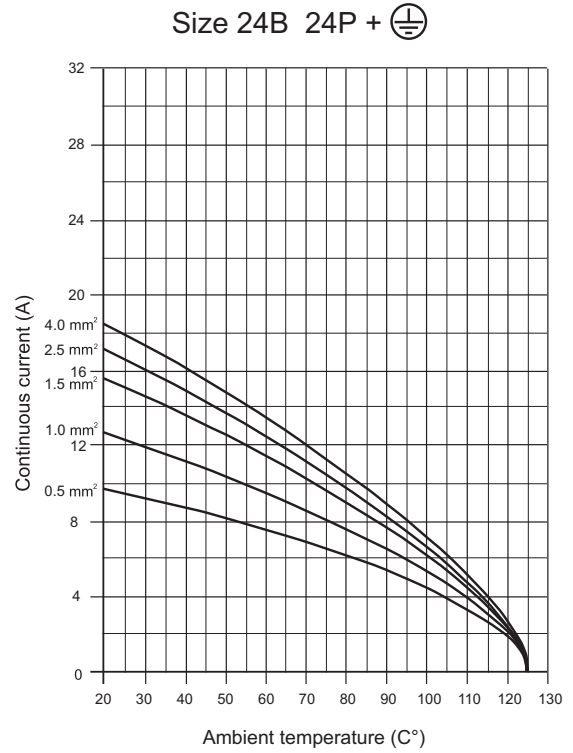
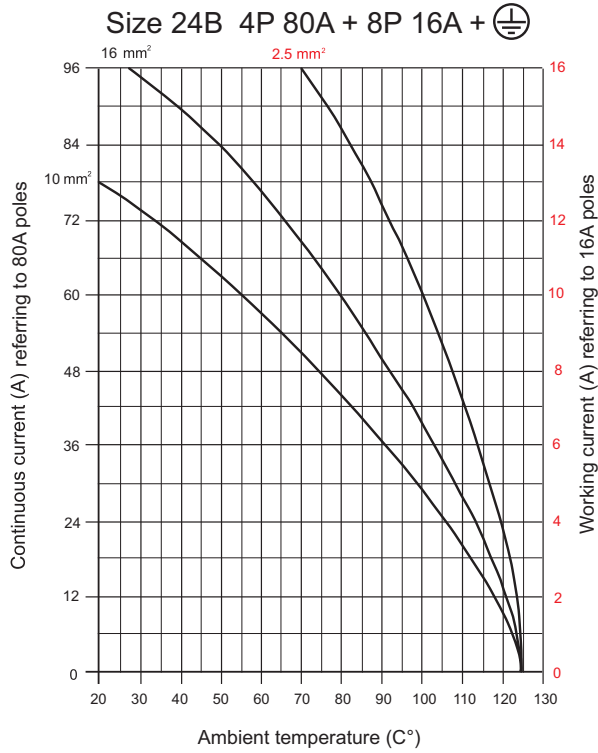



STD Series Multi-Wire Connectors

Electrical Engineering Data - Load Diagrams

Size 32B 32P +

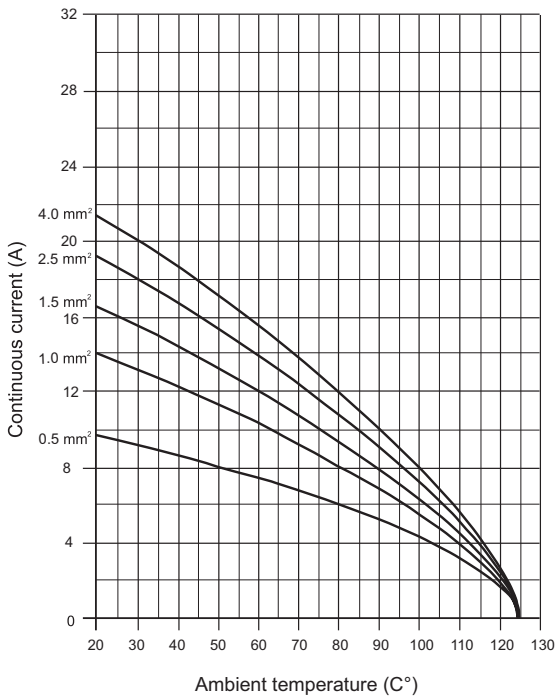

Size 32B 144P +

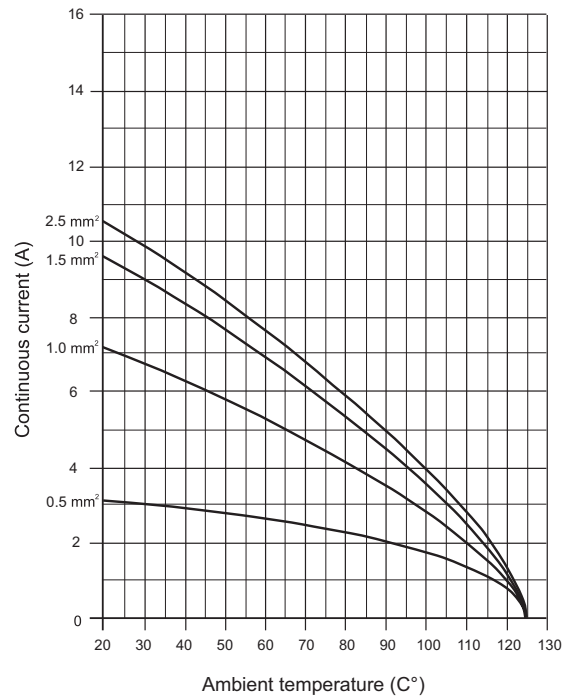



STD Series Multi-Wire Connectors, Spare Parts and Accessories

Crimp Contacts - 10 and 16 Amp

Crimp contacts are made of hard silver-plated or gold-plated copper alloy. Wires to be connected must be carefully matched with the correct wire size of crimp contacts. Crimp contacts should be installed using a crimping tool. For applications with voltages and currents lower than 5V and 5mA gold plated contacts are recommended.

| 10 Amp Crimp Contacts - 100/Pack | | | | | | | | |
|----------------------------------|-------------------|-------|--------------|-------------------|-------|--------------|----------------------------------|------------------|
| | Male | Price | Weight (lb.) | Female | Price | Weight (lb.) | Wire Gauge mm ² [AWG] | Stripping Length |
| Silver-Plated | ZP-MC-CC-M10A-22 | <--> | 0.150 | ZP-MC-CC-F10A-22 | <--> | 0.150 | 0.14-0.37 [26-22] | 8 mm [0.32 in] |
| | ZP-MC-CC-M10A-20 | <--> | 0.150 | ZP-MC-CC-F10A-20 | <--> | 0.140 | 0.5 [20] | |
| | ZP-MC-CC-M10A-18 | <--> | 0.150 | ZP-MC-CC-F10A-18 | <--> | 0.150 | 0.75 [18] | |
| | ZP-MC-CC-M10A-16 | <--> | 0.150 | ZP-MC-CC-F10A-16 | <--> | 0.140 | 1.5 [16] | |
| | ZP-MC-CC-M10A-14 | <--> | 0.140 | ZP-MC-CC-F10A-14 | <--> | 0.150 | 2.5 [14] | |
| Gold-Plated | ZP-MC-CC-M10A-22G | <--> | 0.157 | ZP-MC-CC-F10A-22G | <--> | 0.159 | 0.14-0.37 [26-22] | |
| | ZP-MC-CC-M10A-20G | <--> | 0.150 | ZP-MC-CC-F10A-20G | <--> | 0.157 | 0.5 [20] | |
| | ZP-MC-CC-M10A-18G | <--> | 0.146 | ZP-MC-CC-F10A-18G | <--> | 0.150 | 0.75 [18] | |
| | ZP-MC-CC-M10A-16G | <--> | 0.146 | ZP-MC-CC-F10A-16G | <--> | 0.150 | 1.5 [16] | |
| | ZP-MC-CC-M10A-14G | <--> | 0.146 | ZP-MC-CC-F10A-14G | <--> | 0.152 | 2.5 [14] | |



Male Crimp Contact



Female Crimp Contact

| 16 Amp Crimp Contacts - 100/Pack | | | | | | | | |
|----------------------------------|-------------------|-------|-------------------|-------------------|-------|--------------|----------------------------------|------------------|
| | Male | Price | Weight (lb.) | Female | Price | Weight (lb.) | Wire Gauge mm ² [AWG] | Stripping Length |
| Silver-Plated | ZP-MC-CC-M16A-22 | <--> | 0.280 | ZP-MC-CC-F16A-22 | <--> | 0.280 | 0.14-0.37 [26-22] | 7.5 mm [0.29 in] |
| | ZP-MC-CC-M16A-20 | <--> | 0.360 | ZP-MC-CC-F16A-20 | <--> | 0.350 | 0.5 [20] | |
| | ZP-MC-CC-M16A-18 | <--> | 0.270 | ZP-MC-CC-F16A-18 | <--> | 0.290 | 0.75 [18] | |
| | ZP-MC-CC-M16A-16 | <--> | 0.350 | ZP-MC-CC-F16A-16 | <--> | 0.350 | 1.5 [16] | |
| | ZP-MC-CC-M16A-14 | <--> | 0.270 | ZP-MC-CC-F16A-14 | <--> | 0.280 | 2.5 [14] | |
| Gold-Plated | ZP-MC-CC-M16A-12 | <--> | 0.350 | ZP-MC-CC-F16A-12 | <--> | 0.350 | 4.0 [12] | |
| | ZP-MC-CC-M16A-22G | <--> | 0.280 | ZP-MC-CC-F16A-22G | <--> | 0.322 | 0.14-0.37 [26-22] | |
| | ZP-MC-CC-M16A-20G | <--> | 0.276 | ZP-MC-CC-F16A-20G | <--> | 0.318 | 0.5 [20] | |
| | ZP-MC-CC-M16A-18G | <--> | 0.273 | ZP-MC-CC-F16A-18G | <--> | 0.315 | 0.75 [18] | |
| | ZP-MC-CC-M16A-16G | <--> | 0.273 | ZP-MC-CC-F16A-16G | <--> | 0.320 | 1.5 [16] | |
| | ZP-MC-CC-M16A-14G | <--> | 0.276 | ZP-MC-CC-F16A-14G | <--> | 0.320 | 2.5 [14] | |
| ZP-MC-CC-M16A-12G | <--> | 0.273 | ZP-MC-CC-F16A-12G | <--> | 0.329 | 4.0 [12] | | |



Male Crimp Contact



Female Crimp Contact

Note: The crimp contact ampacities listed above are the Maximum current ratings for the crimp contacts only. The current rating DOES NOT reflect the wire gauge current rating.

| Crimp Contact Tools | | | | |
|---------------------|------|---|-------|--------------|
| Part Number | Qty. | Description | Price | Weight (lb.) |
| ZP-MC-CT1 | 1 | Crimping tool w/dieset and locator | <--> | 1.593 |
| ZP-MC-CT2 | | Crimping tool w/dieset only, no locator | <--> | 0.814 |
| ZP-MC-RT1 | | Removal tool for 10A contacts | <--> | 0.081 |
| ZP-MC-RT2 | | Removal tool for 16A contacts | <--> | 0.086 |



ZP-MC-CT1



ZP-MC-CT2



ZP-MC-RT1



ZP-MC-RT2



STD Series Multi-Wire Connectors, Spare Parts and Accessories

Cable Glands

IP66 Glands

Plastic

- Thread: 1.5 mm pitch in accordance with EN 50262, Pg in accordance with DIN 40430
- IP Protection: IP66 in accordance with EN 60529
- Working Temperature: -40°C to 125°C (-40°F to 257°F)
- Materials: Body - Glass filled polyamide UL 94 V0; Washer - zinc plated steel; Gasket - Elastomer
- Includes two washers and four gaskets to accommodate a wide range of cable diameters
- Applications: for size 3A plastic type housings

Metal

- Thread: 1.5 mm pitch in accordance with EN 50262, Pg in accordance with DIN 40430
- IP Protection: IP66 in accordance with EN 60529
- Working Temperature: -40°C to 125°C (-40°F to 257°F)
- Materials: Body - nickel-plated brass; Washer - zinc plated steel; Gasket - Elastomer
- Includes two washers and four gaskets to accommodate a wide range of cable diameters
- Applications: for all sizes metal type housings

IP68 Glands

Metal

- Thread: 1.5 mm pitch in accordance with EN 50262, Pg in accordance with DIN 40430
- IP Protection: IP68, patented design for up to 5 bars
- Working Temperature: -40°C to 125°C (-40°F to 257°F)
- Materials: Body - nickel-plated brass; Strain relief - Glass filled polyamide UL 94 V0; Gasket - Elastomer
- Applications: for industrial connector housings where higher protection and strength are required

| IP66 Cable Glands | | | | | | |
|-------------------|------|---------|-------------------------|---------|-------|--------------|
| Part Number | Qty. | Type | Cable Diameter mm [in] | Thread | Price | Weight (lb.) |
| ZP-MC-CG-11P5 | 1 | Plastic | 7-12 [0.275-0.472] | Pg 11 | <---> | 0.019 |
| ZP-MC-CG-11M5 | | Metal | 7-12 [0.275-0.472] | Pg 11 | <---> | 0.030 |
| ZP-MC-CG-13M5 | | | 7-12 [0.275-0.472] | Pg 13.5 | <---> | 0.031 |
| ZP-MC-CG-16M5 | | | 7-14.5 [0.275-0.570] | Pg 16 | <---> | 0.041 |
| ZP-MC-CG-21M5 | | | 9.5-18.5 [0.374-0.728] | Pg 21 | <---> | 0.070 |
| ZP-MC-CG-29M5 | | | 17.5-26.5 [0.688-1.043] | Pg 29 | <---> | 0.125 |
| ZP-MC-CG-36M5 | | | 23.5-32.5 [0.925-1.279] | Pg 36 | <---> | 0.249 |

Note: IP66 cable glands with washers CANNOT be used with HC (High Construction) top or side entry housings. You must use the IP68 cable glands. IP66 glands can be used with surface mount HC (High Construction) housings.



IP66 Cable Glands - Plastic



IP66 Cable Glands - Metal



IP68 Cable Glands

| IP68 Cable Glands | | | | | | |
|-------------------|-------------|-------|---------|---------------------|-------|--------------|
| Part Number | Qty. | Type | Thread | Diameter mm [in] | Price | Weight (lb.) |
| ZP-MC-CG-11M8 | 10 per pack | Metal | Pg 11 | 4-10 [0.157-0.393] | <---> | 0.451 |
| ZP-MC-CG-13M8 | | | Pg 13.5 | 5-12 [0.197-0.472] | <---> | 0.780 |
| ZP-MC-CG-16M8 | | | Pg 16 | 8-14 [0.314-0.551] | <---> | 0.881 |
| ZP-MC-CG-21M8 | 5 per pack | | Pg 21 | 11-18 [0.433-0.708] | <---> | 0.727 |
| ZP-MC-CG-29M8 | | | Pg 29 | 16-25 [0.629-0.984] | <---> | 1.466 |
| ZP-MC-CG-36M8 | | | Pg 36 | 19-36 [0.748-1.417] | <---> | 2.205 |



STD Series Multi-Wire Connectors, Spare Parts and Accessories

Blanking Plugs with Gasket

- Thread: 1.5 mm pitch in accordance with EN 50262, Pg in accordance with DIN 40430
- IP Protection: IP68 in accordance with EN 60529
- Working Temperature: -40°C to 125°C (-40°F to 257°F)
- Materials: Body - nickel-plated brass; Gasket - Elastomer
- Applications: for blanking threaded holes on housings or other enclosures

| Blanking Plugs W/Gasket | | | | | |
|-------------------------|-------------|-------|---------|-------|--------------|
| Part Number | Qty. | Type | Thread | Price | Weight (lb.) |
| ZP-MC-PLG-11M8 | 10 per pack | Metal | Pg 11 | <--> | 0.169 |
| ZP-MC-PLG-13M8 | | | Pg 13.5 | <--> | 0.192 |
| ZP-MC-PLG-16M8 | | | Pg 16 | <--> | 0.253 |
| ZP-MC-PLG-21M8 | | | Pg 21 | <--> | 0.478 |
| ZP-MC-PLG-29M8 | 5 per pack | | Pg 29 | <--> | 0.218 |
| ZP-MC-PLG-36M8 | | | Pg 36 | <--> | 0.706 |



Blanking Plugs W/Gasket

Pg to NPT Adapters

- Thread: Metric 1.5 mm pitch Pg in accordance with DIN 40430, NPT in accordance with USAS B2-1
- IP Protection: dependant on coupling and other components
- Working Temperature: -60°C to 200°C (-76°F to 392°F)
- Materials: nickel-plated brass
- Applications: for converting a Pg thread to an NPT thread



Pg to NPT Adapters

| Pg to NPT Adapters | | | | | | |
|--------------------|------|-------|-----------|------------|-------|--------------|
| Part Number | Qty. | Type | Pg Thread | NPT Thread | Price | Weight (lb.) |
| ZP-MC-A-11038 | 1 | Metal | Pg 11 | 3/8" | <--> | 0.044 |
| ZP-MC-A-11012 | | | Pg 11 | 1/2" | <--> | 0.072 |
| ZP-MC-A-13012 | | | Pg 13.5 | 1/2" | <--> | 0.106 |
| ZP-MC-A-16012 | | | Pg 16 | 1/2" | <--> | 0.070 |
| ZP-MC-A-21034 | | | Pg 21 | 3/4" | <--> | 0.101 |
| ZP-MC-A-29100 | | | Pg 29 | 1" | <--> | 0.194 |
| ZP-MC-A-29114 | | | Pg 29 | 1 1/4" | <--> | 0.238 |
| ZP-MC-A-36114 | | | Pg 36 | 1 1/4" | <--> | 0.201 |

Replacement Gaskets

| Replacement Gaskets | | | | | | |
|---------------------|-------------|------|-----------------------|--------------------------------|-------|--------------|
| Part Number | Qty. | Size | Type | Material | Price | Weight (lb.) |
| ZP-MC03A-GSK | 10 per pack | 3A | For bulkhead housings | Nitrile Botadiene Rubber (NBR) | <--> | 0.085 |
| ZP-MC10A-GSK | | 10A | | | <--> | 0.082 |
| ZP-MC16A-GSK | | 16A | | | <--> | 0.079 |
| ZP-MC06B-GSK | | 6B | | | <--> | 0.097 |
| ZP-MC10B-GSK | | 10B | | | <--> | 0.105 |
| ZP-MC16B-GSK | | 16B | | | <--> | 0.127 |
| ZP-MC24B-GSK | | 24B | | | <--> | 0.141 |
| ZP-MC32B-GSK | | 32B | | | <--> | 0.229 |



Replacement Gaskets



STD Series Multi-Wire Connectors, Spare Parts and Accessories

Insert Plates with Cutouts

| Insert Plates with Cutouts | | | | |
|----------------------------|------|---|-------|--------------|
| Part Number | Qty. | Description | Price | Weight (lb.) |
| ZP-MC6B-2-1XDB9 | 1 | 6B housing insert plate with 1 DB9 cutout | <---> | 0.0176 |
| ZP-MC6B-2-2XDB9 | | 6B housing insert plate with 2 DB9 cutouts | <---> | 0.0154 |
| ZP-MC6B-2-1XDB15 | | 6B housing insert plate with 1 DB15 cutout | <---> | 0.0176 |
| ZP-MC6B-2-2XDB15 | | 6B housing insert plate with 2 DB15 cutouts | <---> | 0.0154 |

Note: machine screw M3-0.5x16 hardware not included



Insert Plates with Cutouts



Insert Plates Reducers

| Insert Plates - Reducers | | | | |
|--------------------------|------|---|-------|--------------|
| Part Number | Qty. | Description | Price | Weight (lb.) |
| ZP-MC24B-2-RD6B | 1 | Insert plate allows any 6B insert plate to be used in any size 24B housing | <---> | 0.0838 |
| ZP-MC24B-2-RD10B | | Insert plate allows any 10B insert plate to be used in any size 24B housing | <---> | 0.0816 |
| ZP-MC24B-2-RD16B | | Insert plate allows any 16B insert plate to be used in any size 24B housing | <---> | 0.0772 |

| Insert Plates - Blank | | | | |
|-----------------------|------|---|-------|--------------|
| Part Number | Qty. | Description | Price | Weight (lb.) |
| ZP-MC6B-2-BLANK | 1 | Blank insert plate for any size 6B housing | <---> | 0.4343 |
| ZP-MC10B-2-BLANK | | Blank insert plate for any size 10B housing | <---> | 0.0463 |
| ZP-MC16B-2-BLANK | | Blank insert plate for any size 16B housing | <---> | 0.0529 |
| ZP-MC24B-2-BLANK | | Blank insert plate for any size 24B housing | <---> | 0.0573 |



Insert Plates Blank



STD Series Multi-Wire Connectors, Spare Parts and Accessories

DIN Rail Mounting Kits

- For mounting inserts inside an enclosure
- Fits 35 mm DIN rail

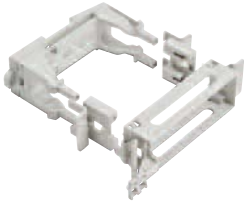

DIN Rail Mounting Kits



ZP-MC-RT3

| DIN Rail Mounting Kits | | | | |
|------------------------|------|----------------------|-------|--------------|
| Part Number | Qty. | Description | Price | Weight (lb.) |
| ZP-MC06B-DKIT | 1 | For size 6B inserts | <--> | 0.374 |
| ZP-MC10B-DKIT | | For size 10B inserts | <--> | 0.377 |
| ZP-MC16B-DKIT | | For size 16B inserts | <--> | 0.385 |
| ZP-MC24B-DKIT | | For size 24B inserts | <--> | 0.392 |
| ZP-MC-RT3 | | Insert removal tool | <--> | 0.052 |

Replacement Screws/Polarization Key

| Replacement Screws / Polarization Key | | | | | |
|---------------------------------------|-----------------------|--|-------|--------------|-------|
| Part Number | Qty. | Description | Price | Weight (lb.) | |
| ZP-MC-SCRWKIT | 2 pieces of each part | M3.5 - PE screw for size 3A inserts | | <--> | 0.048 |
| | | M4 - PE screw for size 6B insert, size 10B insert, size 16B insert (16+PE) and size 24B insert (24+PE) | | | |
| | | M4 - PE screw for size 16B insert (6+PE) and size 24B insert (8+4+PE) | | | |
| | | M3 - Installation screw for 3A inserts only | | | |
| | | M3 - Installation screw for all inserts except 3A | | | |
| ZP-MC-POLKEY1 | 12 | Polarization key for size 3A 12-pin inserts. Two keys are required per coupled connection. | <--> | 0.011 | |

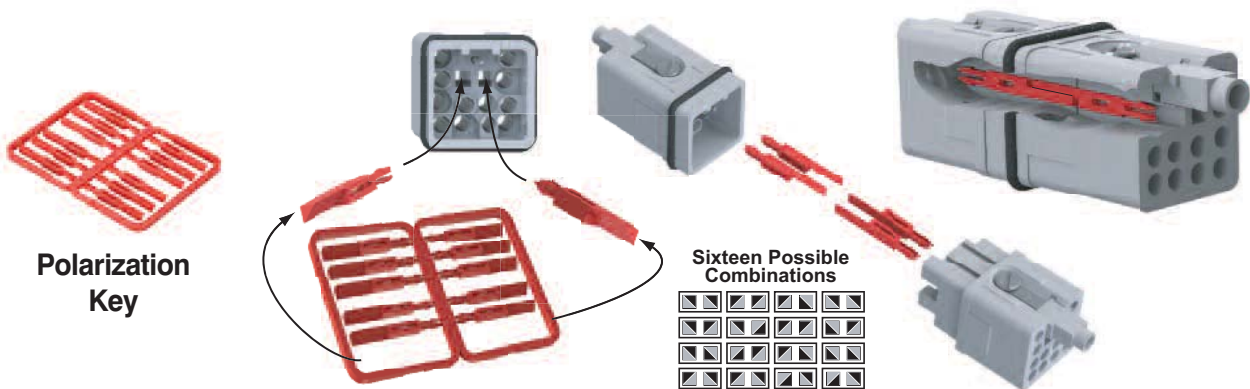

Using the Polarization Key



STD Series Multi-Wire Connectors, Spare Parts and Accessories



Company Information

Systems Overview

Programmable Controllers

Field I/O

Software

C-more & other HMI

Drives

Soft Starters

Motors & Gearbox

Steppers/Servos

Motor Controls

Proximity Sensors

Photo Sensors

Limit Switches

Encoders

Current Sensors

Pressure Sensors

Temperature Sensors

Pushbuttons/Lights

Process

Relays/Timers

Comm.

Terminal Blocks & Wiring

Power

Circuit Protection

Enclosures

Tools

Pneumatics

Safety

Appendix

Product Index

Part # Index

| Code Pins | | | | | |
|-----------------|-------|---|--------|-------|--------------|
| Part Number | Qty. | Description | Figure | Price | Weight (lb.) |
| ZP-MC-CODEPIN-2 | 16/pk | Single code pin | 1 | <---> | 0.009 |
| ZP-MC-CODEPIN-3 | 16/pk | Male code pin (use w/ZP-MC-CODEPIN-4) | 2 | <---> | 0.064 |
| ZP-MC-CODEPIN-4 | 16/pk | Female code pin (use w/ZP-MC-CODEPIN-3) | 3 | <---> | 0.101 |

* Code pins are used in applications where there are identical connectors that could be coupled with the incorrect mate, potentially causing equipment damage or breakdown. Code pins replace the installation screws on the inserts. Code pins do NOT work with 3A inserts or 32x13 inserts. The following combinations of code pins allow for a selective number of couples. Material is zinc-plated steel.



Figure 1



Figure 2



Figure 3

Coding Pin Configurations

Single Code Pin

The ZP-MC-CODEPIN-2 is designed to be used as a single stand-alone code pin using the following configurations.

Application with single insert

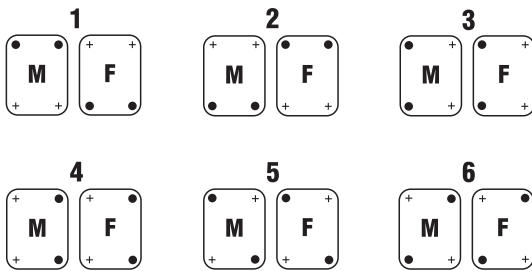

- Code pin ZP-MC-CODEPIN-2
- + Normal fixing screw
- M** Male insert
- F** Female insert

Application with double insert

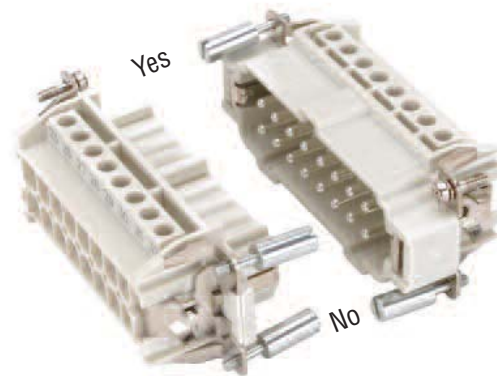
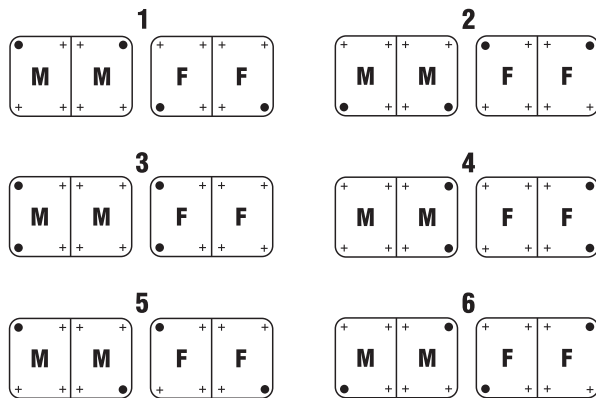



STD Series Multi-Wire Connectors, Spare Parts and Accessories

Coding Pin Configurations

Male / Female Code Pins

The ZP-MC-CODEPIN-3 and the ZP-MC-CODEPIN-4 are designed to be used together using the following configurations.

Application with single insert

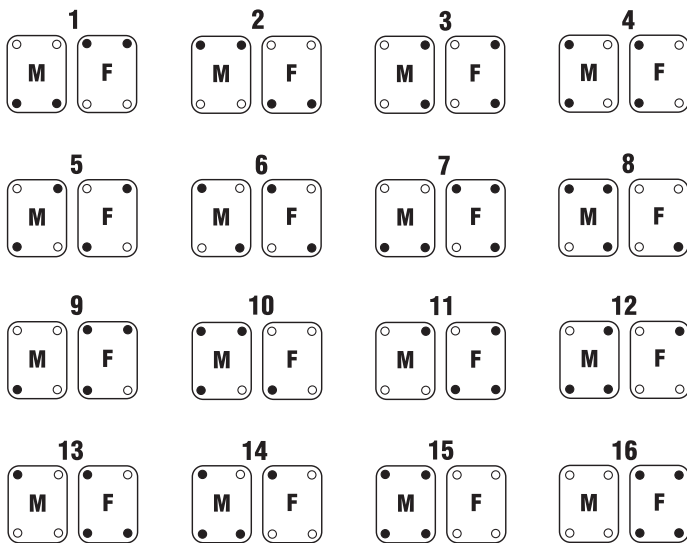

Application with double insert

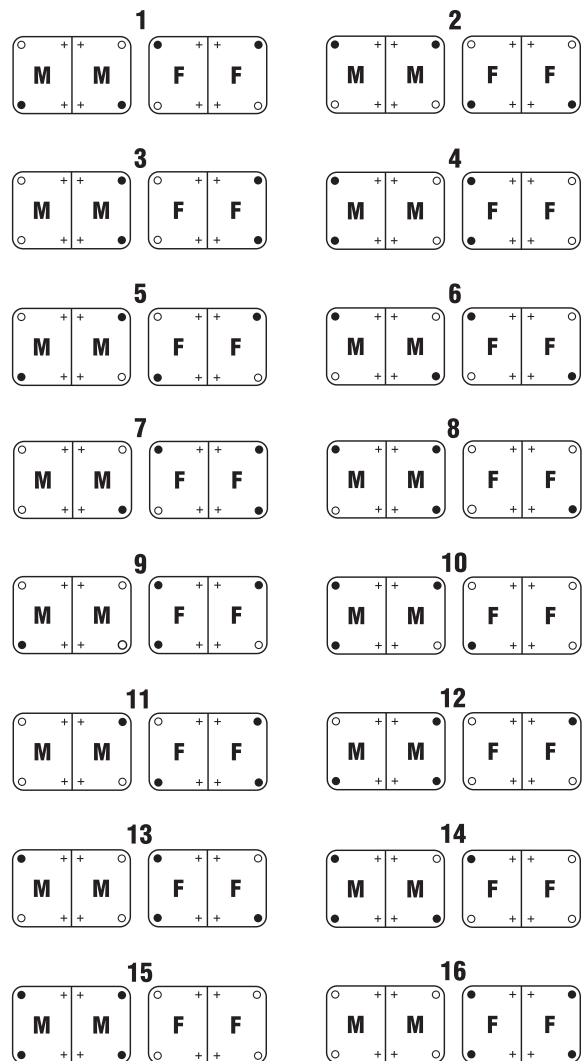

- Male code pin ZP-MC-CODEPIN-3
- Female code pin ZP-MC-CODEPIN-4
- ⊕ Normal fixing screw
- M** Male insert
- F** Female insert

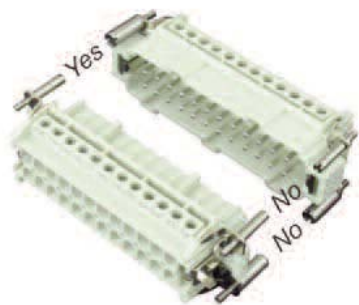



STD Series Multi-Wire Dimensions

Size 3A Inserts

Dimensions mm [in]

3 + \oplus – Screw Terminals

Male

Female

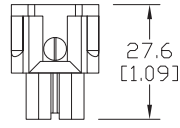
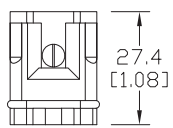
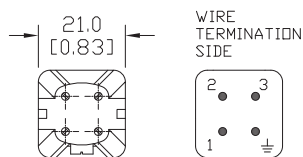
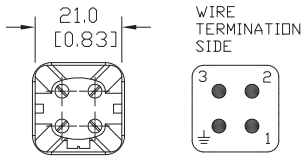

ZP-MC03A-1-MS003

ZP-MC03A-1-FS003

4 + \oplus – Screw Terminals

Male

Female

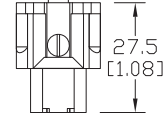
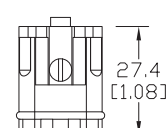
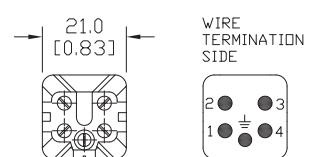
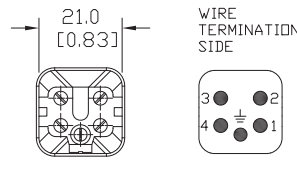

ZP-MC03A-1-MS004

ZP-MC03A-1-FS004

5 + \oplus – Crimp Contacts

Male

Female

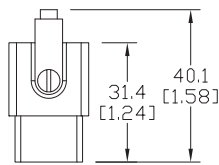
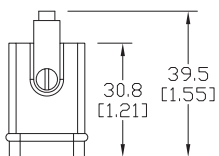
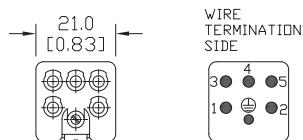
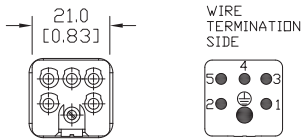

ZP-MC03A-1-MC005

ZP-MC03A-1-FC005

7 + \oplus – Crimp Contacts

Male

Female

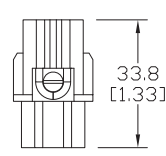
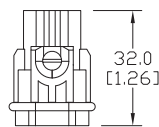
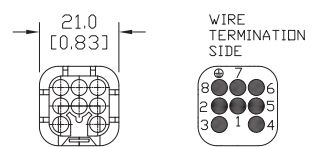
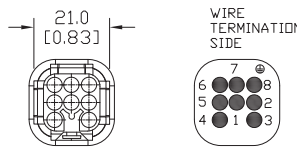

ZP-MC03A-1-MC007

ZP-MC03A-1-FC007

12 + \oplus – Crimp Contacts

Male

Female

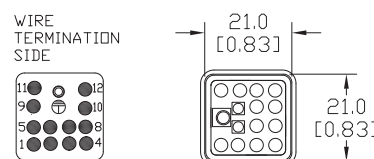
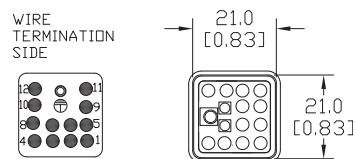
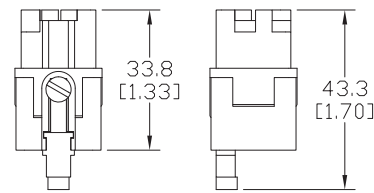
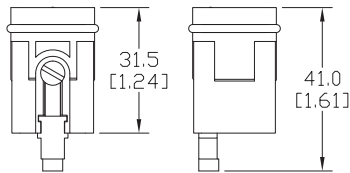

ZP-MC03A-1-MC012

ZP-MC03A-1-FC012



STD Series Multi-Wire Dimensions

Size 3A Hoods and Housings

Dimensions mm [in]

Straight Hood

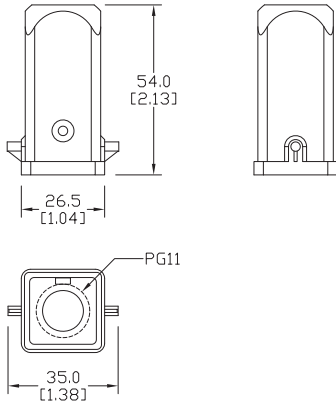

ZP-MC03A-2-STE11M/P

Angled Hood

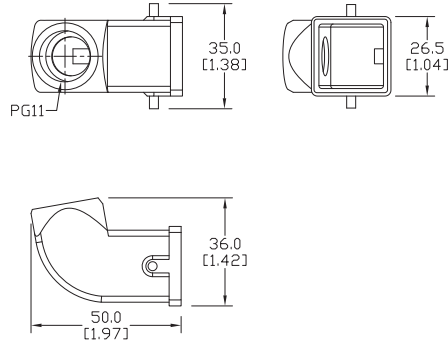

ZP-MC03A-2-SSE11M/P

Bulkhead Straight Base

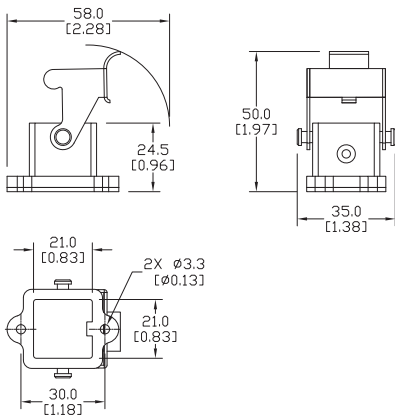

ZP-MC03A-2-SBHM/P

Bulkhead Angled Base

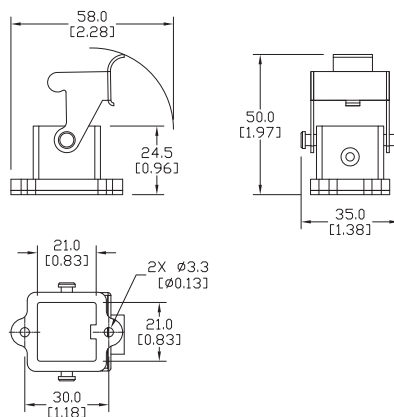

ZP-MC03A-2-SBHAM/P

Surface Mount Base

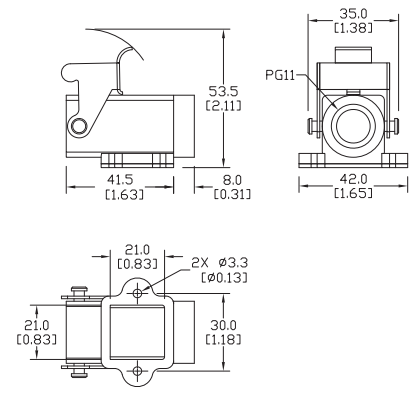

ZP-MC03A-2-SSM11M/P

Coupler

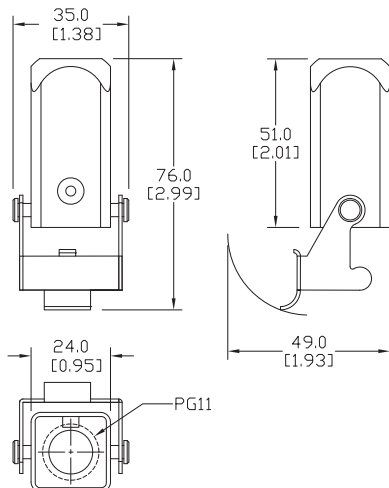

ZP-MC03A-2-SCP11M/P

Cover

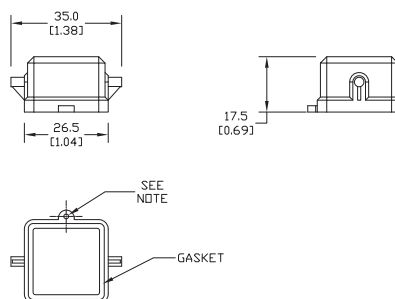

Note: Includes attached 112 mm [4.40 inch] nylon cord with ring terminal

ZP-MC03A-2-SCVPMM/P
ZP-MC03A-2-SCVPFM/P



STD Series Multi-Wire Dimensions

Size 10A Inserts

Dimensions mm [in]

10 + \oplus - Screw Terminals

Male

Female

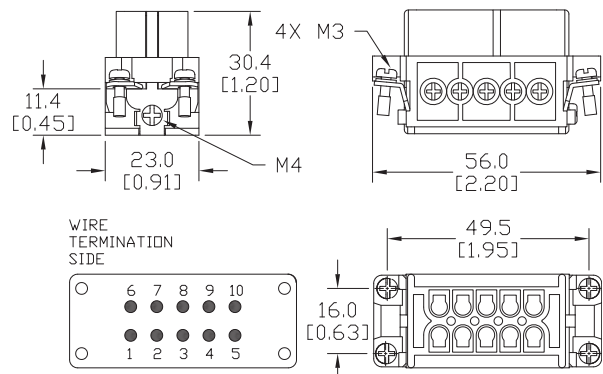
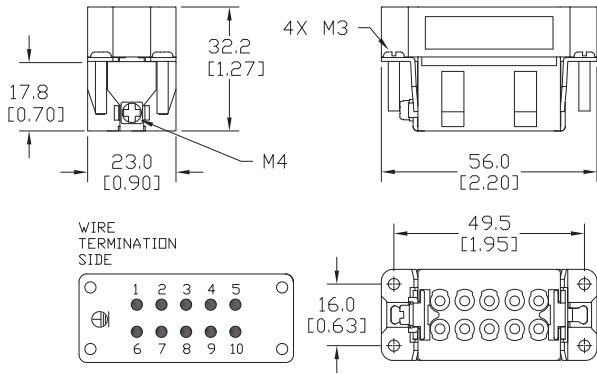

ZP-MC10A-1-MS010

ZP-MC10A-1-FS010

10 + \oplus - Crimp Contacts

Male

Female

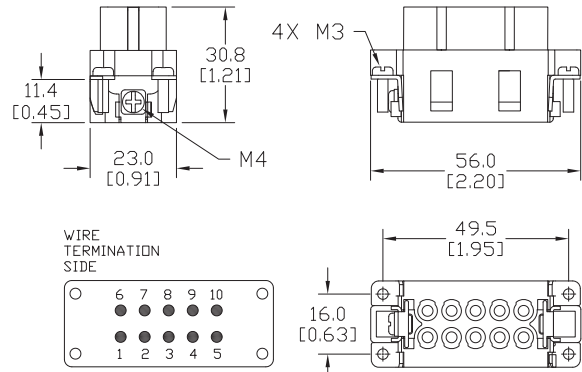
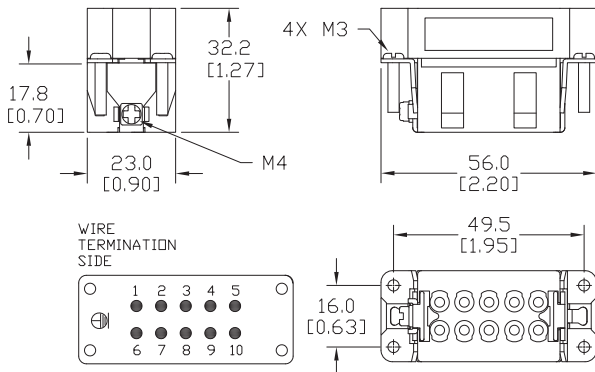

ZP-MC10A-1-MC010

ZP-MC10A-1-FC010

15 + \oplus - Crimp Contacts

Male

Female

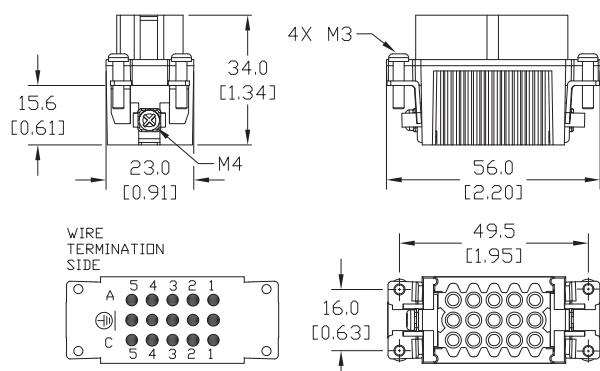
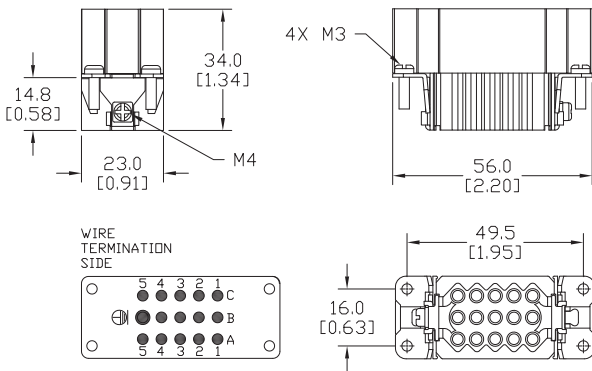

ZP-MC10A-1-MC015

ZP-MC10A-1-FC015



STD Series Multi-Wire Dimensions

Size 16A Inserts

Dimensions mm [in]

16 + \oplus – Screw Terminals

Male

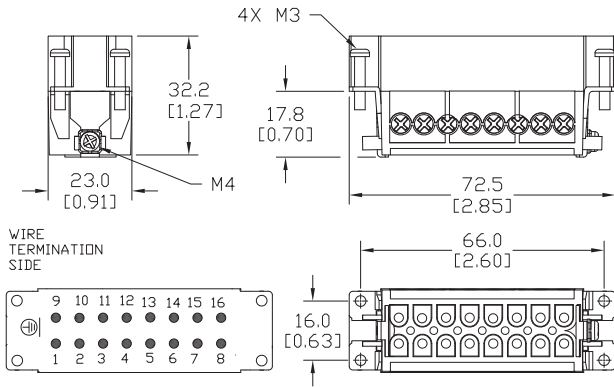

ZP-MC16A-1-MS016

Female

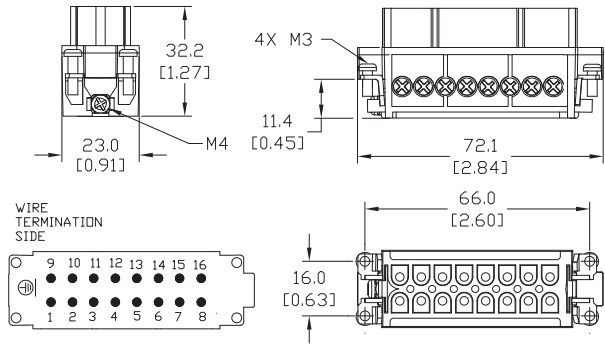

ZP-MC16A-1-FS016

16 + \oplus – Crimp Contacts

Male

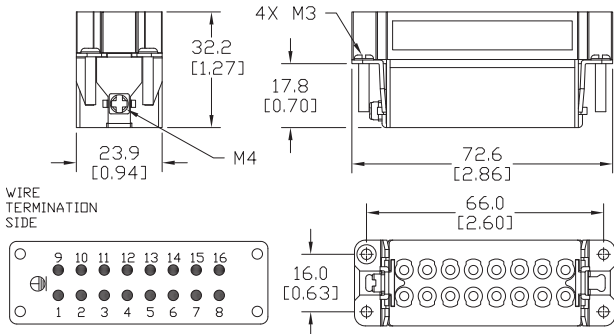

ZP-MC16A-1-MC016

Female

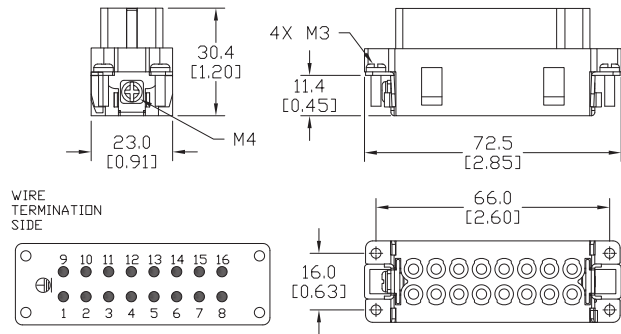

ZP-MC16A-1-FC016

25 + \oplus – Crimp Contacts

Male

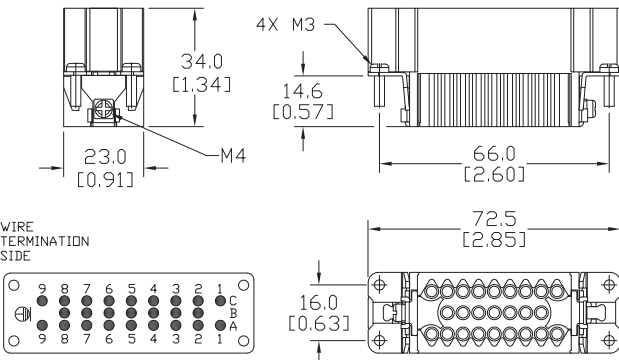

ZP-MC16A-1-MC025

Female

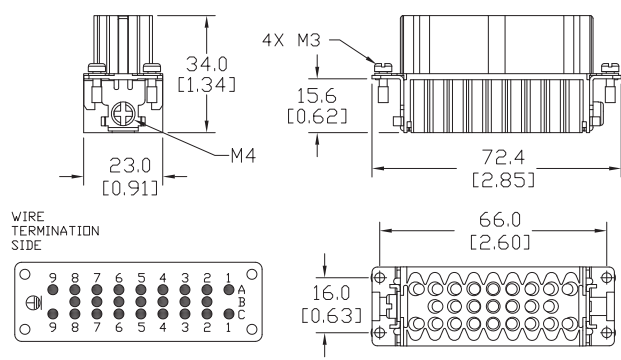

ZP-MC16A-1-FC025



STD Series Multi-Wire Dimensions

Size 10A, 16A Hoods and Housings

Dimensions mm [in]

Single Lever Top Entry Hood

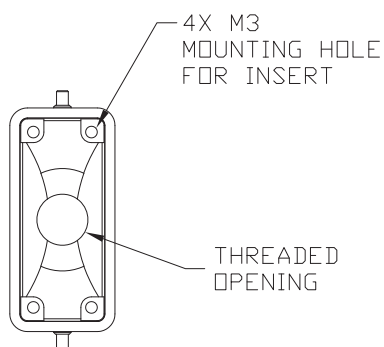
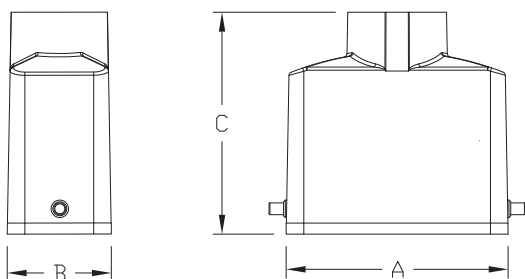

| Part Number | Size | Thread | A | B | C |
|-------------------|------|---------|----------------|----------------|----------------|
| ZP-MC10A-2-STE13M | 10A | Pg 13.5 | 63.0 [2.48] | 29.6 [1.17] | 63.0 [2.48] |
| ZP-MC10A-2-STE16M | | Pg 16 | | | |
| ZP-MC16A-2-STE13M | 16A | Pg 13.5 | 79.5 [3.13] | 29.6 [1.17] | 63.0 [2.48] |
| ZP-MC16A-2-STE16M | | Pg 16 | | | |

Single Lever Top Entry High Construction Hood

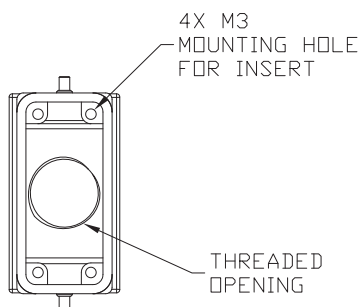
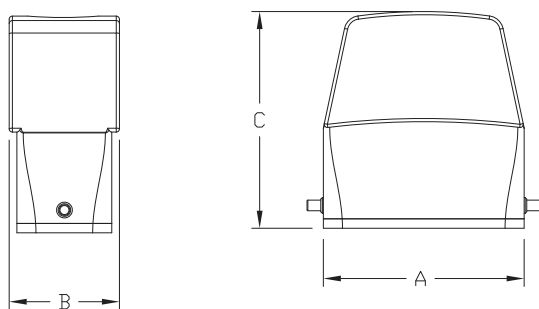

| Part Number | Size | Thread | A | B | C |
|--------------------|------|--------|----------------|----------------|----------------|
| ZP-MC10A-2-STE16ML | 10A | Pg 16 | 63.0 [2.48] | 34.6 [1.36] | 68.0 [2.68] |
| ZP-MC10A-2-STE21ML | | Pg 21 | | | |
| ZP-MC16A-2-STE16ML | 16A | Pg 16 | 79.5 [3.13] | 34.6 [1.36] | 71.0 [2.79] |
| ZP-MC16A-2-STE21ML | | Pg 21 | | | |



STD Series Multi-Wire Dimensions

Size 10A, 16A Hoods and Housings

Dimensions mm [in]

Single Lever Side Entry Hood

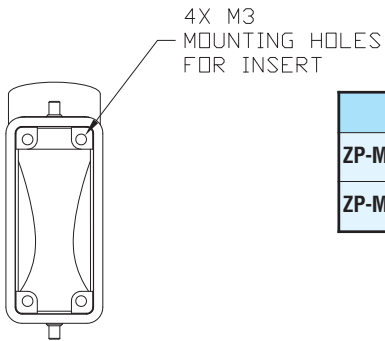
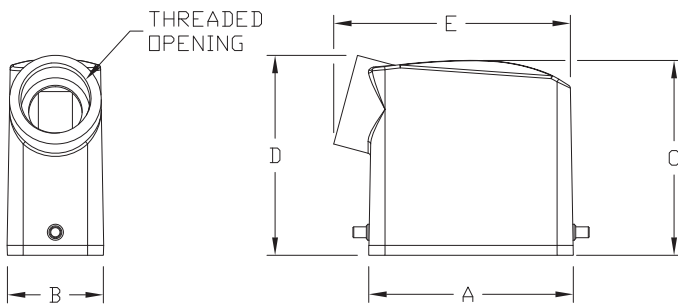

| Part Number | Size | Thread | A | B | C | D | E |
|-------------------|------|--------|----------------|----------------|----------------|----------------|----------------|
| ZP-MC10A-2-SSE16M | 10A | Pg 16 | 63.0 [2.48] | 29.6 [1.17] | 60.0 [2.36] | 61.6 [2.43] | 72.9 [2.87] |
| ZP-MC16A-2-SSE16M | 16A | | 79.5 [3.13] | 29.6 [1.17] | 60.0 [2.36] | 61.6 [2.43] | 89.8 [3.54] |

Single Lever Side Entry High Construction Hood

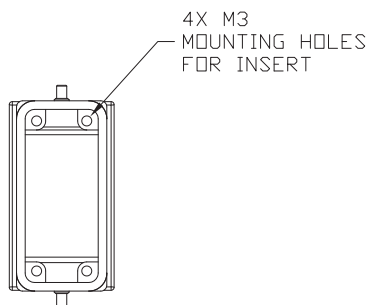
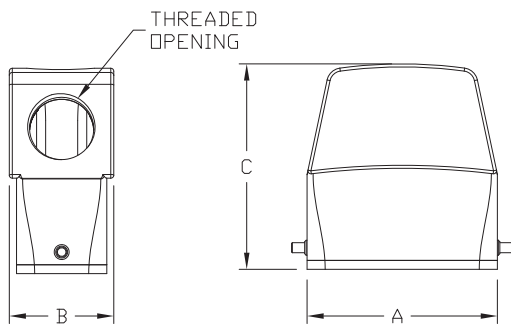

| Part Number | Size | Thread | A | B | C |
|--------------------|------|--------|--------|--------|--------|
| ZP-MC10A-2-SSE16ML | 10A | Pg 16 | 63.0 | 34.6 | 68.0 |
| ZP-MC10A-2-SSE21ML | | Pg 21 | [2.48] | [1.36] | [2.68] |
| ZP-MC16A-2-SSE16ML | 16A | Pg 16 | 79.5 | 34.6 | 71.0 |
| ZP-MC16A-2-SSE21ML | | Pg 21 | [3.13] | [1.36] | [2.79] |



STD Series Multi-Wire Dimensions

Size 10A, 16A Hoods and Housings

Dimensions mm [in]

Single Lever Surface Mount Base With Cover

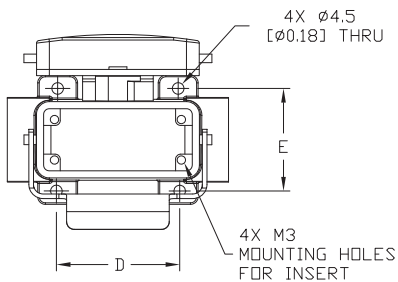

| Part Number | Size | Thread | A | B | C | D | E | F | G | H |
|--------------------|------|---------|--------|--------|--------|--------|--------|--------|--------|--------|
| ZP-MC10A-2-SSM16MC | 10A | Pg 16x2 | 85.5 | 50.0 | 52.5 | 48.0 | 40.0 | 79.4 | 100.9 | 111.4 |
| ZP-MC10A-2-SSM21MC | | Pg 21x2 | [3.37] | [1.97] | [2.07] | [1.89] | [1.57] | [3.13] | [3.97] | [4.39] |
| ZP-MC16A-2-SSM16MC | 16A | Pg 16x2 | 102.0 | 50.0 | 57.0 | 64.0 | 40.0 | 79.4 | 106.0 | 114.5 |
| ZP-MC16A-2-SSM21MC | | Pg 21x2 | [4.02] | [1.97] | [2.24] | [2.52] | [1.57] | [3.13] | [4.17] | [4.51] |

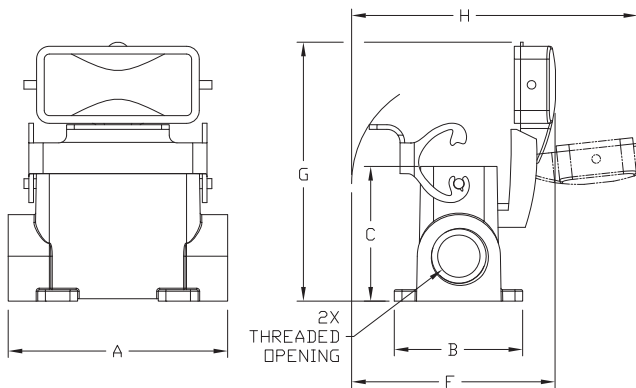

Single Lever Surface Mount Base

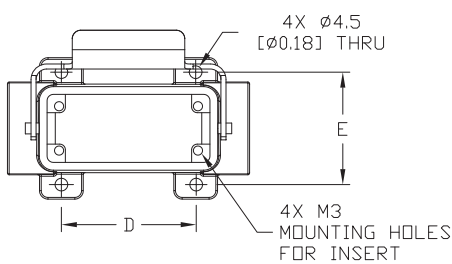

| Part Number | Size | Thread | A | B | C | D | E | F |
|-------------------|------|---------|--------|--------|--------|--------|--------|--------|
| ZP-MC10A-2-SSM16M | 10A | Pg 16x2 | 85.5 | 50.0 | 52.5 | 48.0 | 40.0 | 63.6 |
| ZP-MC10A-2-SSM21M | | Pg 21x2 | [3.37] | [1.97] | [2.07] | [1.89] | [1.57] | [2.50] |
| ZP-MC16A-2-SSM16M | 16A | Pg 16x2 | 102.0 | 50.0 | 57.0 | 64.0 | 40.0 | 63.6 |
| ZP-MC16A-2-SSM21M | | Pg 21x2 | [4.02] | [1.97] | [2.24] | [2.52] | [1.57] | [2.50] |

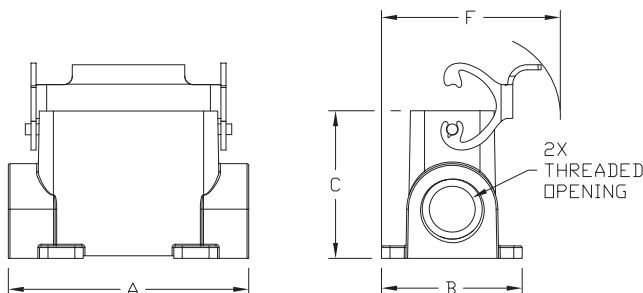



STD Series Multi-Wire Dimensions

Size 10A, 16A Hoods and Housings

Dimensions mm [in]

Single Lever Bulkhead Base

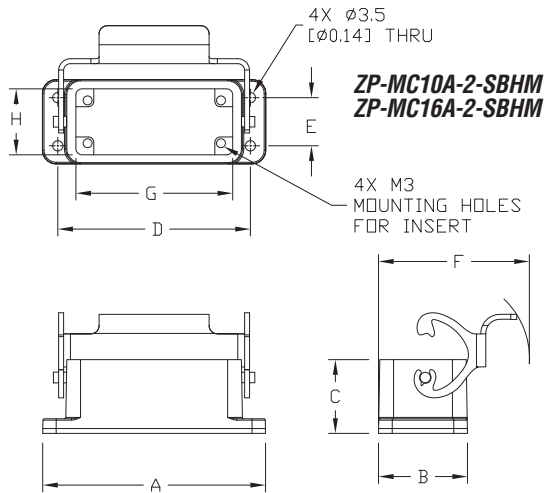

| Part Number | Size | A | B | C | D | E | F | G* | H* |
|-----------------|------|----------------|----------------|----------------|----------------|----------------|----------------|----------------|----------------|
| ZP-MC10A-2-SBHM | 10A | 81.0 [3.19] | 32.3 [1.27] | 26.8 [1.06] | 70.0 [2.76] | 17.5 [0.69] | 54.8 [2.16] | 57.0 [2.24] | 24.0 [0.94] |
| ZP-MC16A-2-SBHM | 16A | 96.0 [3.78] | 32.3 [1.27] | 26.8 [1.06] | 86.0 [3.39] | 17.5 [0.69] | 54.8 [2.16] | 73.0 [2.87] | 24.0 [0.94] |

*Dimensions G and H refer to cutout size

Single Lever Cover

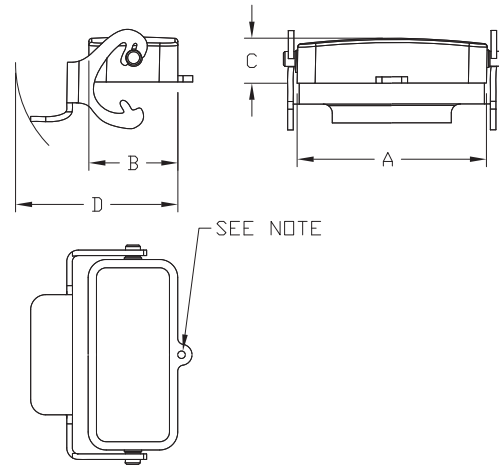

| Part Number | Size | A | B | C | D |
|------------------|------|----------------|----------------|----------------|----------------|
| ZP-MC10A-2-SCVLM | 10A | 63.0 [2.48] | 29.6 [1.17] | 15.0 [0.59] | 54.0 [2.13] |
| ZP-MC16A-2-SCVLM | 16A | 79.5 [3.13] | 29.6 [1.17] | 15.0 [0.59] | 54.0 [2.13] |

Single Lever Bulkhead Base with Cover

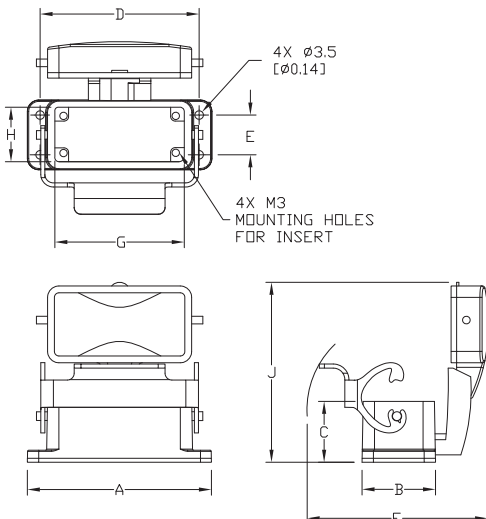

| Part Number | Size | A | B | C | D | E | F | G* | H* | J |
|-----------------|------|----------------|----------------|----------------|----------------|----------------|----------------|----------------|----------------|----------------|
| ZP-MC10A-2-SBHM | 10A | 81.0 [3.19] | 32.3 [1.27] | 26.8 [1.06] | 70.0 [2.76] | 17.5 [0.69] | 79.4 [3.13] | 57.0 [2.24] | 24.0 [0.94] | 76.0 [2.99] |
| ZP-MC16A-2-SBHM | 16A | 96.0 [3.78] | 32.3 [1.27] | 26.8 [1.06] | 86.0 [3.39] | 17.5 [0.69] | 79.4 [3.13] | 73.0 [2.87] | 24.0 [0.94] | 76.0 [2.99] |

*Dimensions G and H refer to cutout size

Two Peg Cover

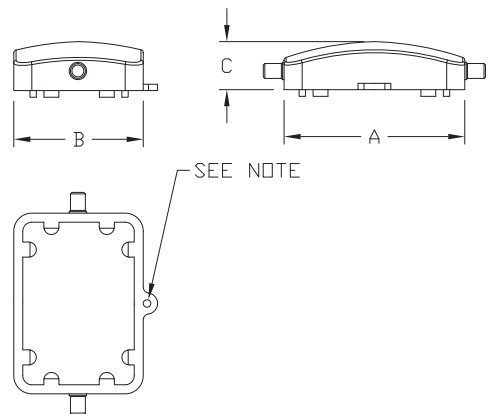

| Part Number | Size | A | B | C |
|------------------|------|----------------|----------------|----------------|
| ZP-MC10A-2-SCVPM | 10A | 63.0 [2.48] | 29.6 [1.17] | 16.0 [0.63] |
| ZP-MC16A-2-SCVPM | 16A | 79.5 [3.13] | 29.6 [1.17] | 16.0 [0.63] |

Note: Includes attached 112 mm [4.40 inch] nylon cord with ring terminal



STD Series Multi-Wire Dimensions

Size 6B Inserts

Dimensions mm [in]

6 + - Screw Terminals

Male

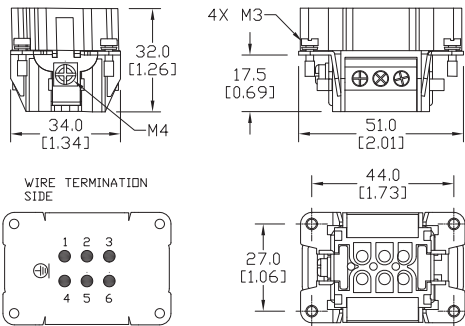

ZP-MC06B-1-MS006

Female

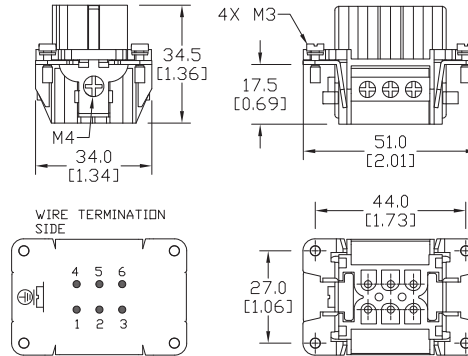

ZP-MC06B-1-FS006

6 + - Crimp Contacts

Male

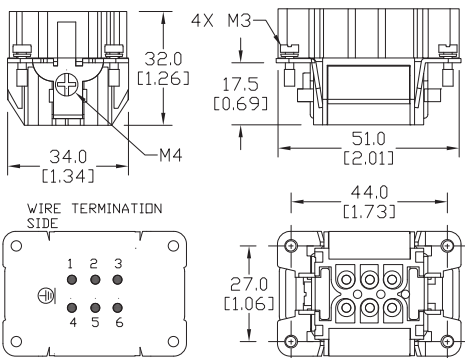

ZP-MC06B-1-MC006

Female

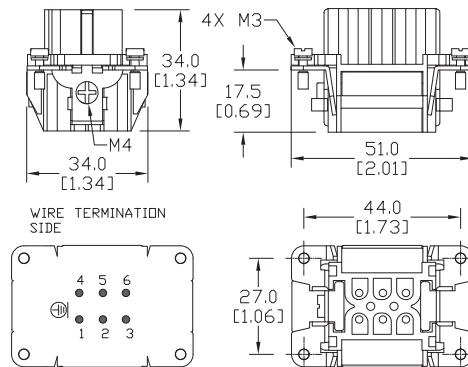

ZP-MC06B-1-FC006

24 + - Crimp Contacts

Male

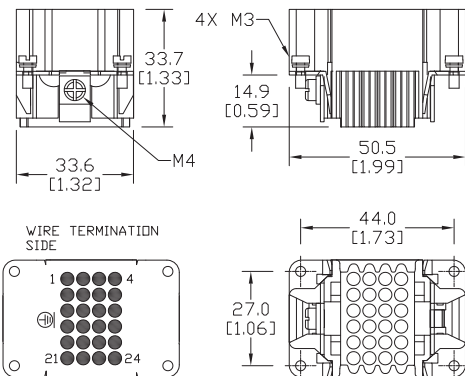

ZP-MC06B-1-MC024

Female

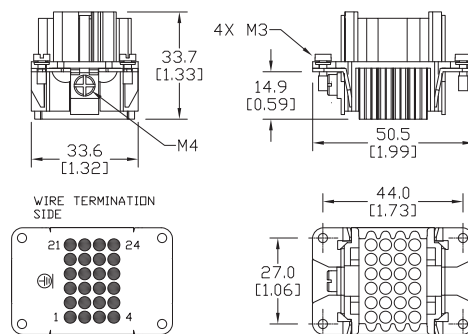

ZP-MC06B-1-FC024



STD Series Multi-Wire Dimensions

Size 10B Inserts

Dimensions mm [in]

10 + \oplus – Screw Terminals

Male

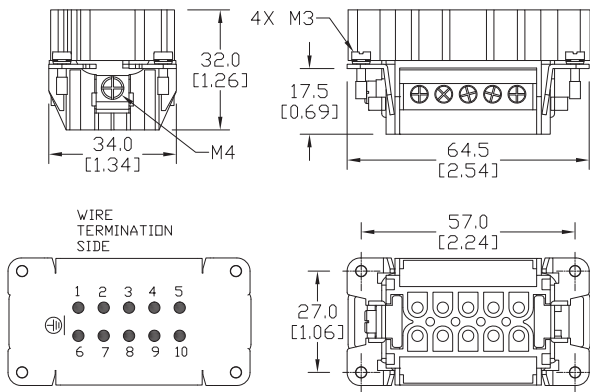

ZP-MC10B-1-MS010

Female

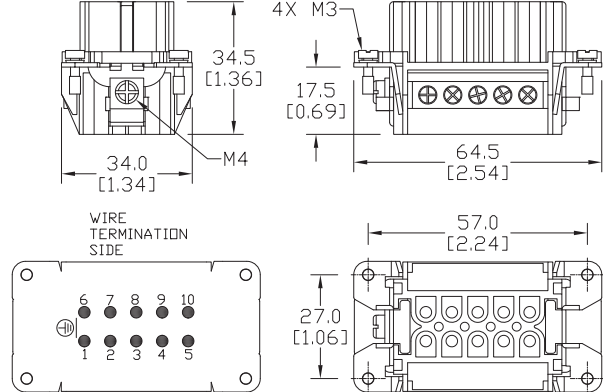

ZP-MC10B-1-FS010

10 + \oplus – Crimp Contacts

Male

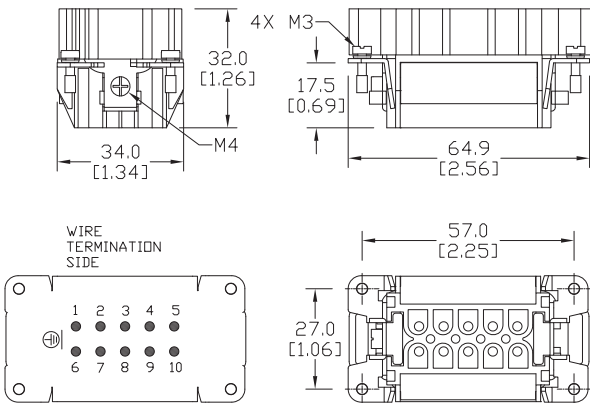

ZP-MC10B-1-MC010

Female

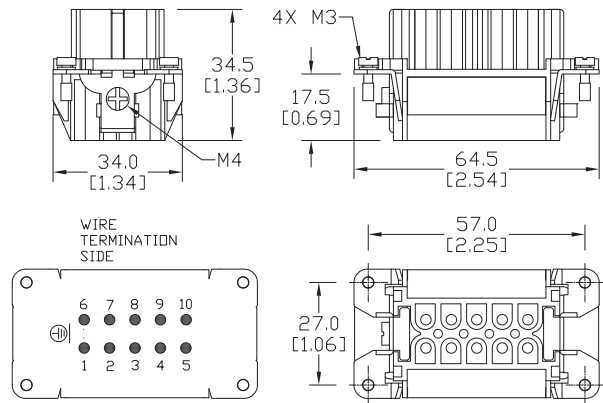

ZP-MC10B-1-FC010

42 + \oplus – Crimp Contacts

Male

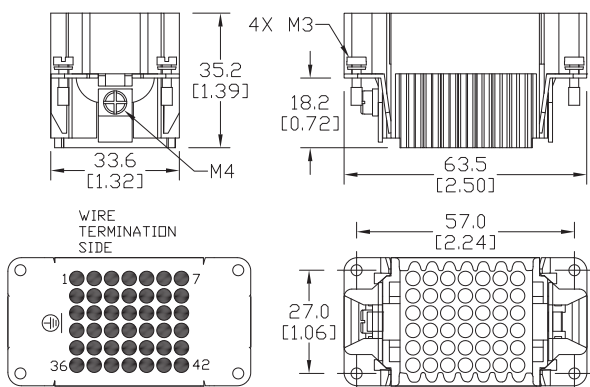

ZP-MC10B-1-MC042

Female

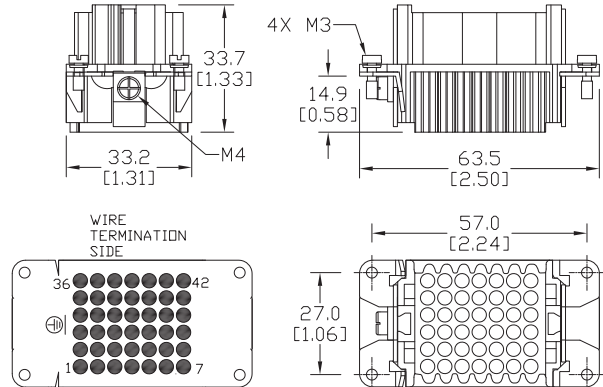

ZP-MC10B-1-FC042



STD Series Multi-Wire Dimensions

Size 16B Inserts Dimensions mm [in]

6 + - Screw Terminals

Male

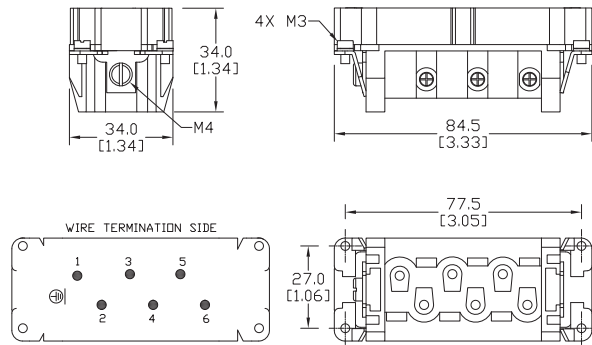

ZP-MC16B-1-MS006

Female

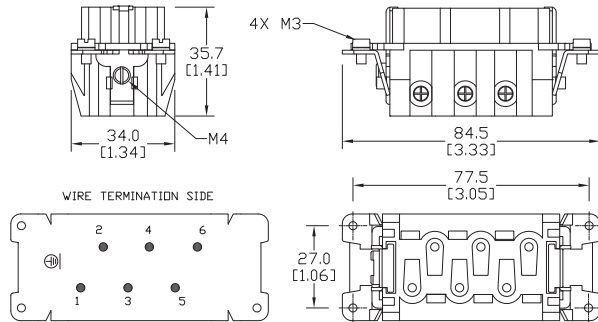

ZP-MC16B-1-FS006

16 + - Screw Terminals

Male

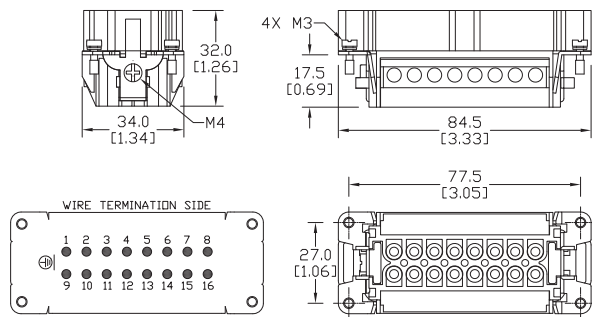

ZP-MC16B-1-MS016

Female

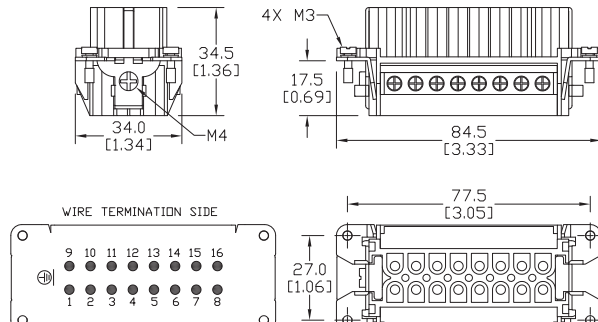

ZP-MC16B-1-FS006

16 + - Crimp Contacts

Male

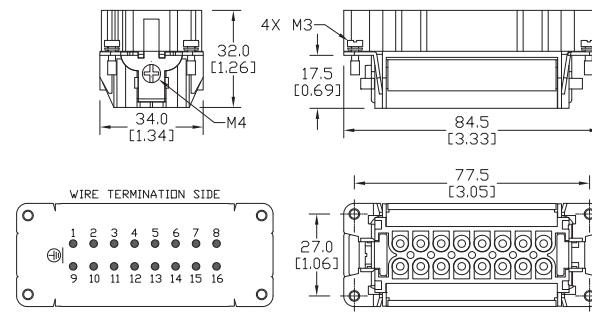

ZP-MC16B-1-MC016

Female

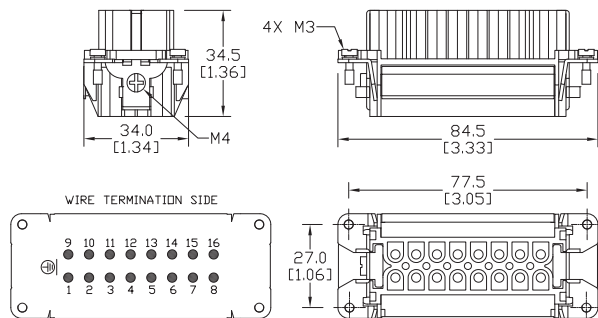

ZP-MC16B-1-FC016



STD Series Multi-Wire Dimensions

Size 16B Inserts

Dimensions mm [in]

40 + \oplus – Crimp Contacts

Male

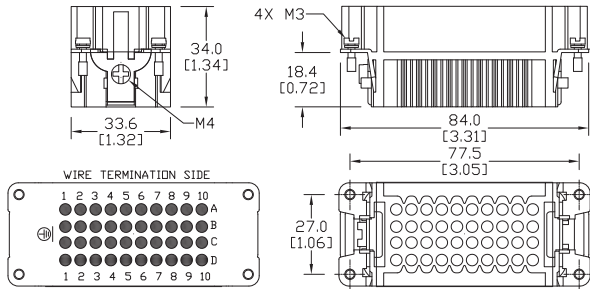

ZP-MC16B-1-MC040

Female

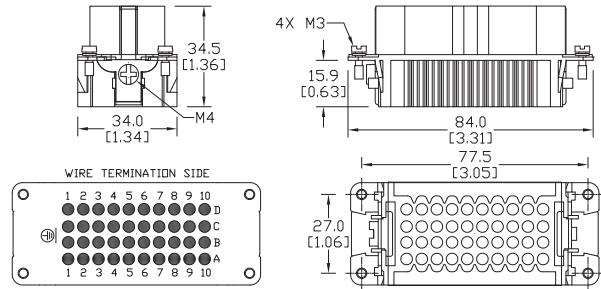

ZP-MC16B-1-FC040

72 + \oplus – Crimp Contacts

Male

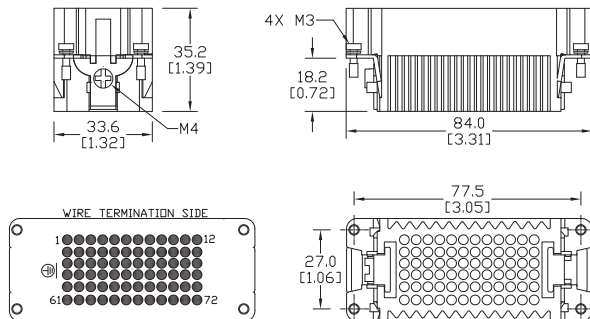

ZP-MC16B-1-MC072

Female

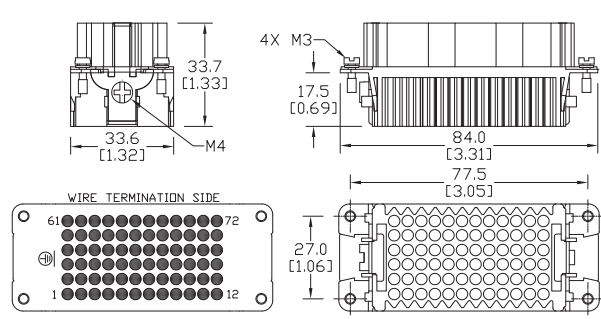

ZP-MC16B-1-FC072



STD Series Multi-Wire Dimensions

Size 24B Inserts

Dimensions mm [in]

8 + 4 + \oplus – Screw Terminals

Male

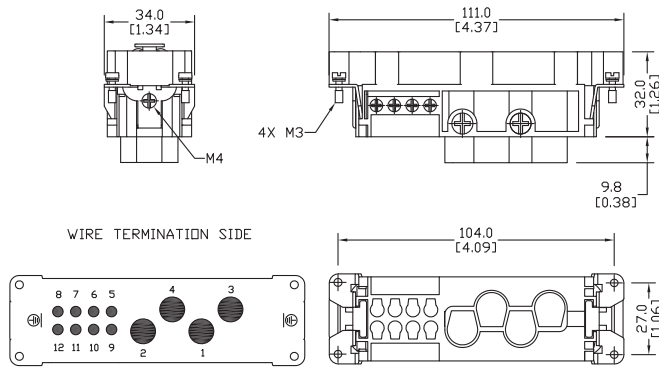

ZP-MC24B-1-MS048

Female

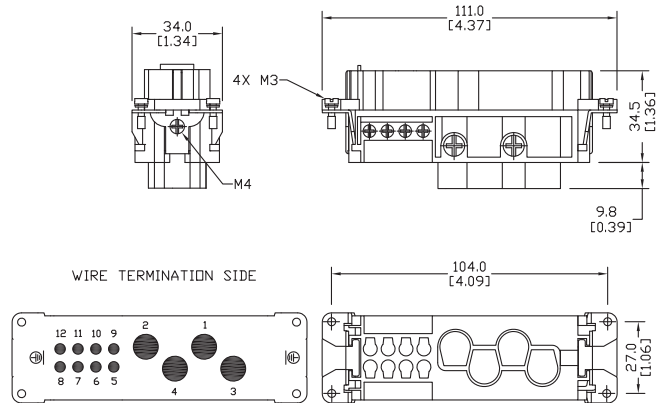

ZP-MC24B-1-FS048

24 + \oplus – Screw Terminals

Male

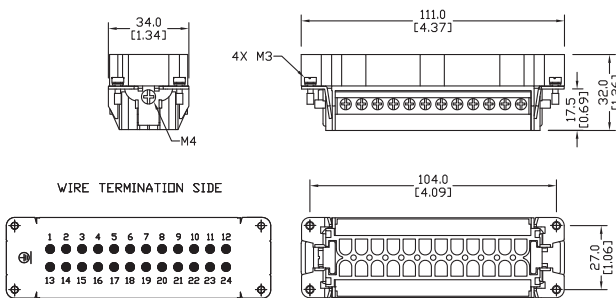

ZP-MC24B-1-MS024

Female

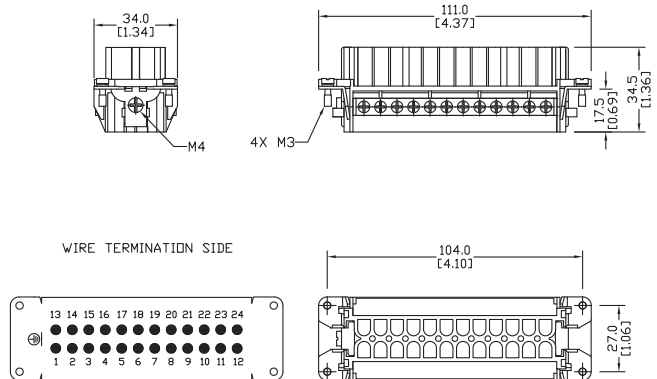

ZP-MC24B-1-FS024

24 + \oplus – Crimp Contacts

Male

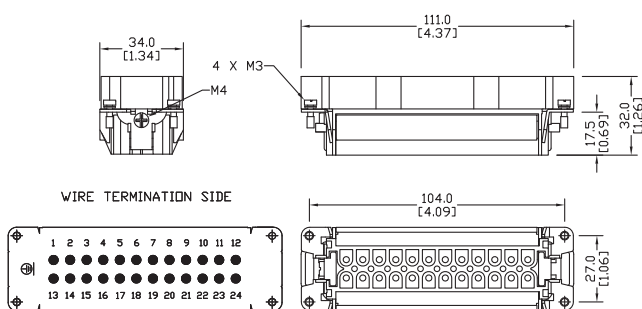

ZP-MC24B-1-MC024

Female

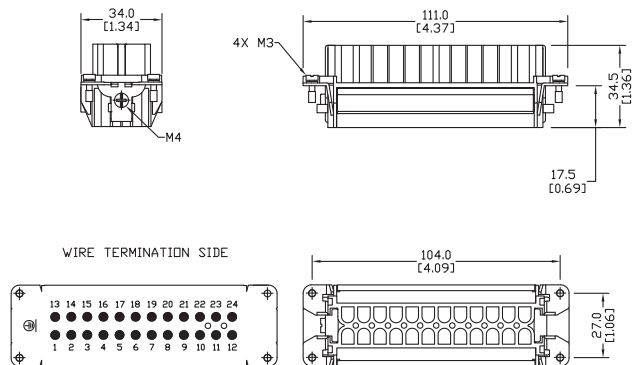

ZP-MC24B-1-FC024



STD Series Multi-Wire Dimensions

Size 24B Inserts

Dimensions mm [in]

64 + – Crimp Contacts

Male

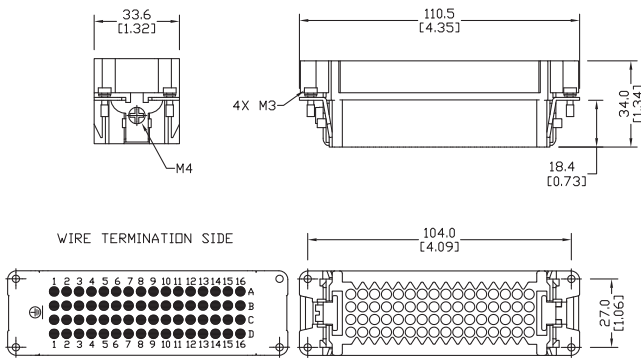

ZP-MC24B-1-MC064

Female

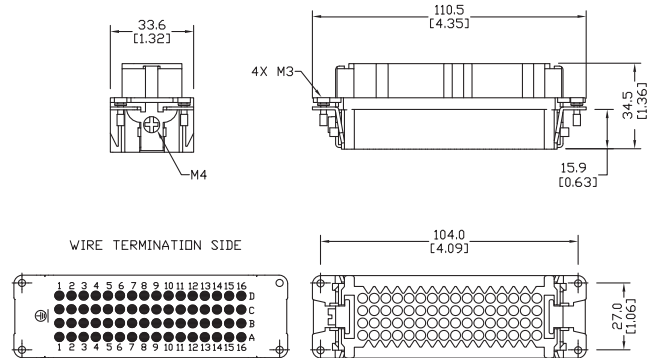

ZP-MC24B-1-FC064

108 + – Crimp Contacts

Male

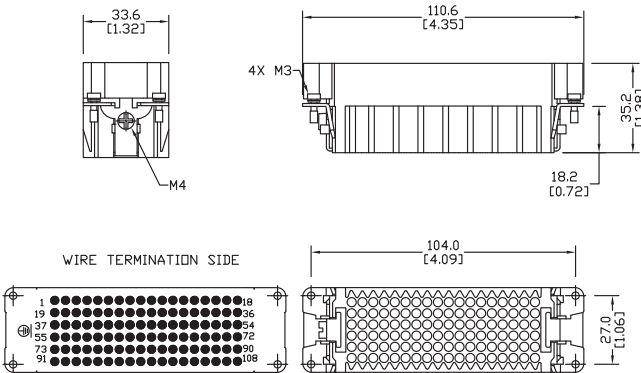

ZP-MC24B-1-MC108

Female

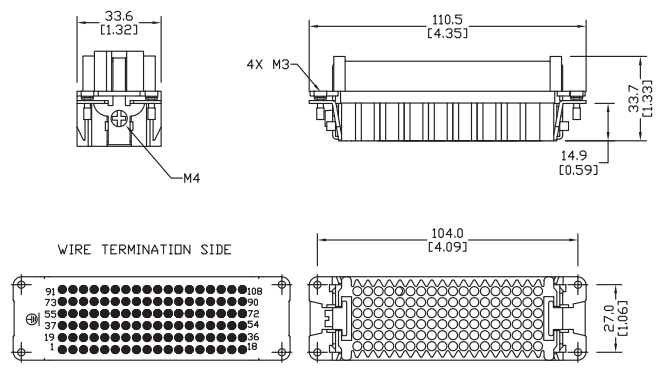

ZP-MC24B-1-FC108



STD Series Multi-Wire Dimensions

Size 32B Inserts

Dimensions mm [in]

32 + \oplus – Screw Terminals

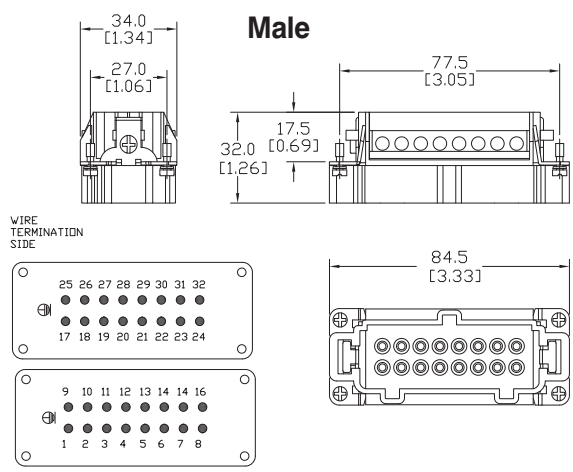

ZP-MC16B-1-MS016 & ZP-MC16B-1-MS016-2

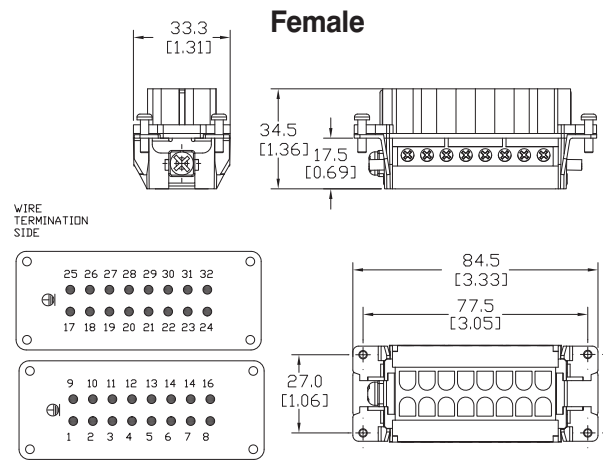

ZP-MC16B-1-FS016 & ZP-MC16B-1-FS016-2

32 + \oplus – Crimp Contacts

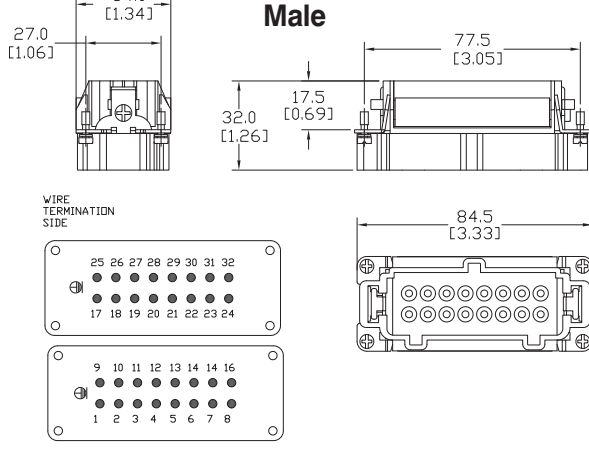

ZP-MC16B-1-MC016 & ZP-MC16B-1-MC016-2

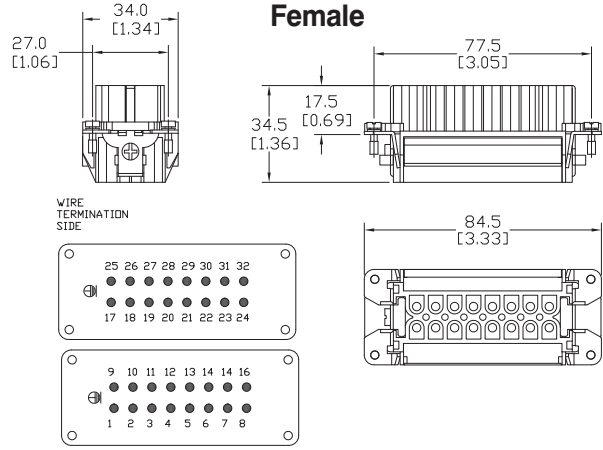

ZP-MC16B-1-FC016 & ZP-MC16B-1-FC016-2

144 + \oplus – Crimp Contacts

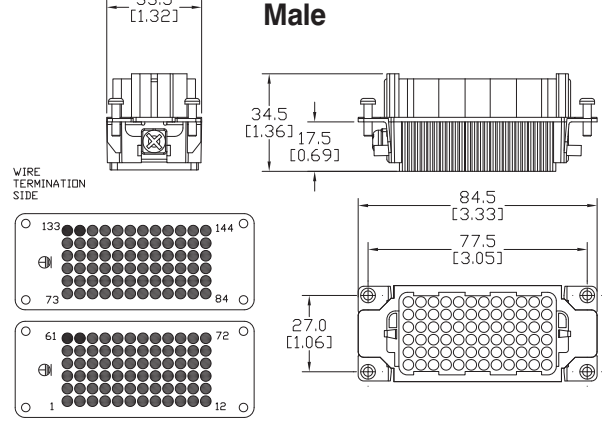

ZP-MC16B-1-MC072 & ZP-MC16B-1-MC072-2

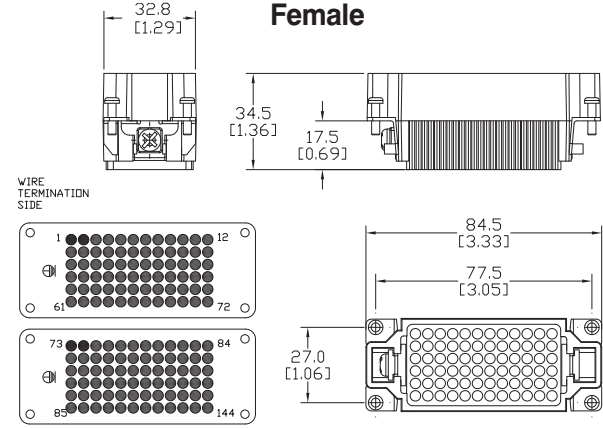

ZP-MC16B-1-FC072 & ZP-MC16B-1-FC072-2



STD Series Multi-Wire Dimensions

Size 6B, 10B, 16B, 24B, 32B Hoods

Dimensions mm [in]

Single Lever Top Entry Hood

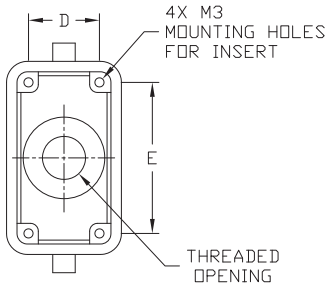
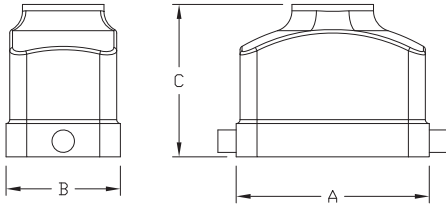

Single Lever Top Entry High Construction Hood

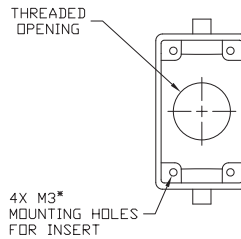
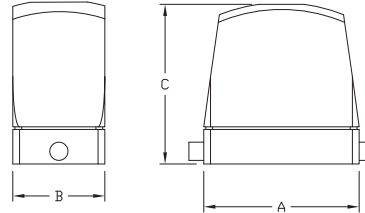

| Part Number | Size | Thread | A | B | C | D | E |
|-------------------|------|--------|-----------------|----------------|----------------|----------------|-----------------|
| ZP-MC06B-2-STE16M | 6B | Pg 16 | 60.0 [2.36] | 43.5 [1.71] | 53.0 [2.09] | 27.0 [1.06] | 44.0 [1.73] |
| ZP-MC10B-2-STE16M | 10B | Pg 16 | 73.5 [2.89] | 43.5 [1.71] | 58.0 [2.28] | 27.0 [1.06] | 57.0 [2.24] |
| ZP-MC16B-2-STE21M | 16B | Pg 21 | 94 [3.70] | 43.5 [1.71] | 58.0 [2.28] | 27.0 [1.06] | 77.5 [3.05] |
| ZP-MC24B-2-STE21M | 24B | Pg 21 | 120.5 [4.74] | 43.5 [1.71] | 68.0 [2.68] | 27.0 [1.06] | 104.0 [4.09] |

| Part Number | Size | Thread | A | B | C |
|--------------------|------|--------|--------|--------|--------|
| ZP-MC06B-2-STE21ML | 6B | Pg 21 | 60.0 | 43.5 | 75.0 |
| ZP-MC06B-2-STE29ML | | Pg 29 | [2.36] | [1.71] | [2.95] |
| ZP-MC10B-2-STE21ML | 10B | Pg 21 | 73.5 | 43.5 | 75.5 |
| ZP-MC10B-2-STE29ML | | Pg 29 | [2.89] | [1.71] | [2.97] |
| ZP-MC16B-2-STE21ML | 16B | Pg 21 | 94.0 | 43.5 | 75.5 |
| ZP-MC16B-2-STE29ML | | Pg 29 | [3.70] | [1.71] | [2.97] |
| ZP-MC24B-2-STE21ML | 24B | Pg 21, | 120.5 | 43.5 | 75.5 |
| ZP-MC24B-2-STE29ML | | Pg 29 | [4.74] | [1.71] | [2.97] |
| ZP-MC32B-2-STE36M | 32B | Pg 36 | 94.0 | 83.0 | 89.0 |
| | | | [3.70] | [3.27] | [3.50] |

Single Lever Side Entry Hood

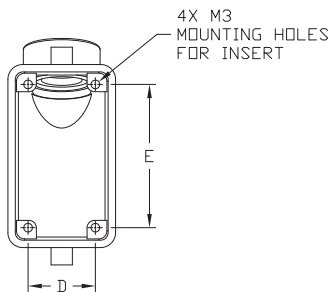
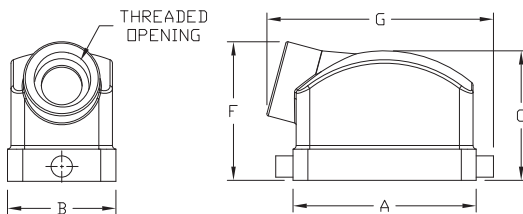

Single Lever Side Entry High Construction Hood

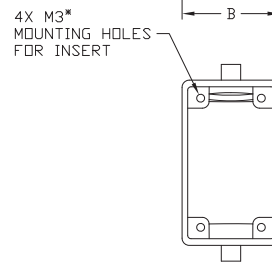
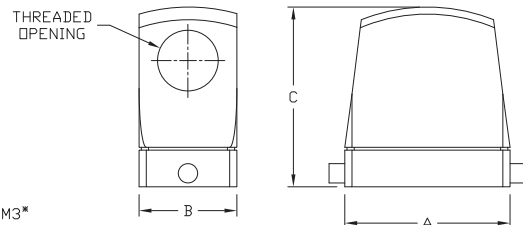

| Part Number | Size | Thread | A | B | C | D | E | F | G |
|-------------------|------|--------|-----------------|----------------|----------------|----------------|-----------------|----------------|-----------------|
| ZP-MC06B-2-SSE16M | 6B | Pg 16 | 60.0 [2.36] | 43.5 [1.71] | 47.0 [1.85] | 27.0 [1.06] | 44.0 [1.73] | 54.0 [2.13] | 78.5 [3.09] |
| ZP-MC10B-2-SSE16M | 10B | Pg 16 | 73.5 [2.89] | 43.5 [1.71] | 52.0 [2.05] | 27.0 [1.06] | 57.0 [2.24] | 55.6 [2.19] | 90.9 [3.58] |
| ZP-MC16B-2-SSE21M | 16B | Pg 21 | 94.0 [3.70] | 43.5 [1.71] | 63.0 [2.48] | 27.0 [1.06] | 77.5 [3.05] | 66.2 [2.61] | 109.7 [4.32] |
| ZP-MC24B-2-SSE21M | 24B | Pg 21 | 120.5 [4.74] | 43.5 [1.71] | 63.0 [2.48] | 27.0 [1.06] | 104.0 [4.09] | 65.4 [2.58] | 136.4 [5.37] |

| Part Number | Size | Thread | A | B | C |
|--------------------|------|--------|--------|--------|--------|
| ZP-MC06B-2-SSE21ML | 6B | Pg 21 | 60.0 | 43.5 | 80.0 |
| ZP-MC06B-2-SSE29ML | | Pg 29 | [2.36] | [1.71] | [3.15] |
| ZP-MC10B-2-SSE21ML | 10B | Pg 21 | 73.5 | 43.5 | 80.0 |
| ZP-MC10B-2-SSE29ML | | Pg 29 | [2.90] | [1.71] | [3.15] |
| ZP-MC16B-2-SSE21ML | 16B | Pg 21 | 94.0 | 43.5 | 80.0 |
| ZP-MC16B-2-SSE29ML | | Pg 29 | [3.70] | [1.71] | [3.15] |
| ZP-MC24B-2-SSE21ML | 24B | Pg 21 | 120.5 | 43.5 | 80.0 |
| ZP-MC24B-2-SSE29ML | | Pg 29 | [4.74] | [1.71] | [3.15] |
| ZP-MC32B-2-SSE36M | 32B | Pg 36 | 94.0 | 83.0 | 94.0 |
| | | | [3.70] | [3.27] | [3.70] |

Note: Size 32B hoods require 2 of the 16B inserts.

ZIPport® STD Series Multi-Wire Dimensions

Size 10B, 16B, 24B, 32B Hoods

Dimensions mm [in]

Double Lever Top Entry Hood

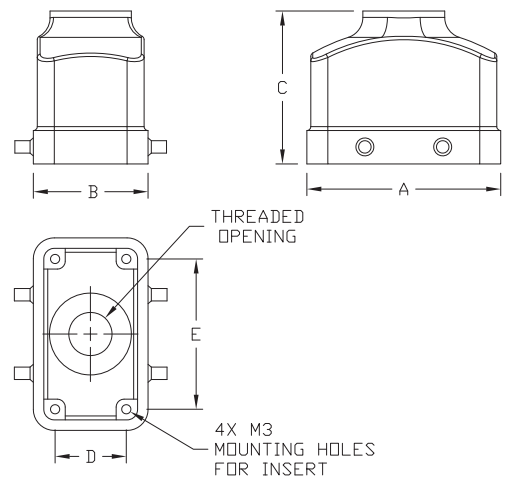

| Part Number | Size | Thread | A | B | C | D | E |
|-------------------|------|--------|-----------------|----------------|----------------|----------------|-----------------|
| ZP-MC10B-2-DTE16M | 10B | Pg 16 | 73.5 [2.89] | 43.5 [1.71] | 58.0 [2.28] | 27.0 [1.06] | 57.0 [2.24] |
| ZP-MC16B-2-DTE21M | 16B | Pg 21 | 94.0 [3.70] | 43.5 [1.71] | 58.0 [2.28] | 27.0 [1.06] | 77.5 [3.05] |
| ZP-MC24B-2-DTE21M | 24B | Pg 21 | 120.5 [4.74] | 43.5 [1.71] | 68.0 [2.68] | 27.0 [1.06] | 104.0 [4.09] |
| ZP-MC24B-2-DTE29M | | Pg 29 | | | | | |

Double Lever Top Entry High Construction Hood

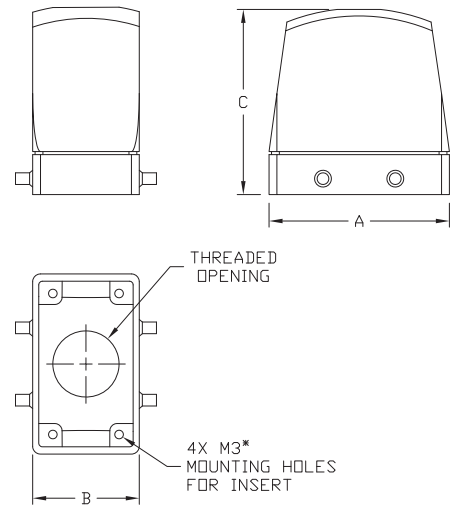

| Part Number | Size | Thread | A | B | C |
|--------------------|------|--------|-----------------|----------------|----------------|
| ZP-MC10B-2-DTE21ML | 10B | Pg 21 | 73.5 [2.89] | 43.5 [1.71] | 75.5 [2.97] |
| ZP-MC10B-2-DTE29ML | | Pg 29 | | | |
| ZP-MC16B-2-DTE21ML | 16B | Pg 21 | 94.0 [3.70] | 43.5 [1.71] | 75.5 [2.97] |
| ZP-MC16B-2-DTE29ML | | Pg 29 | | | |
| ZP-MC24B-2-DTE21ML | 24B | Pg 21 | 120.5 [4.74] | 43.5 [1.71] | 75.5 [2.97] |
| ZP-MC24B-2-DTE29ML | | Pg 29 | | | |
| ZP-MC32B-2-DTE36M | 32B* | Pg 36 | 94.0 [3.70] | 83.0 [3.27] | 89.0 [3.50] |

*Note: Size 32B hoods require 2 of the 16B inserts.

Double Lever Side Entry Hood

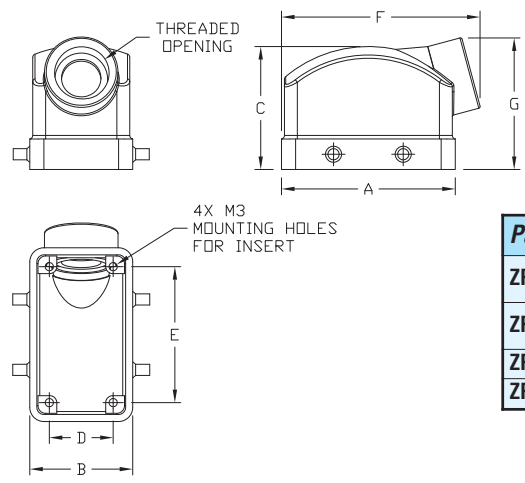

| Part Number | Size | Thread | A | B | C | D | E | F | G |
|-------------------|------|--------|-----------------|----------------|----------------|----------------|-----------------|----------------|-----------------|
| ZP-MC10B-2-DSE16M | 10B | Pg 16 | 73.5 [2.89] | 43.5 [1.71] | 52.0 [2.05] | 27.5 [1.08] | 57.5 [2.26] | 57.5 [2.26] | 83.9 [3.30] |
| ZP-MC16B-2-DSE21M | 16B | Pg 21 | 94.0 [3.70] | 43.5 [1.71] | 63.0 [2.48] | 27.5 [1.08] | 77.5 [3.05] | 58.0 [2.28] | 102.7 [4.04] |
| ZP-MC24B-2-DSE21M | 24B | Pg 21 | 120.5 [4.74] | 43.5 [1.71] | 63.0 [2.48] | 27.5 [1.08] | 104.0 [4.09] | 57.0 [2.24] | 129.3 [5.09] |
| ZP-MC24B-2-DSE29M | | Pg 29 | | | | | | | |



STD Series Multi-Wire Dimensions

Size 10B, 16B, 24B, 32B Hoods

Dimensions mm [in]

Double Lever Side Entry High Construction Hood

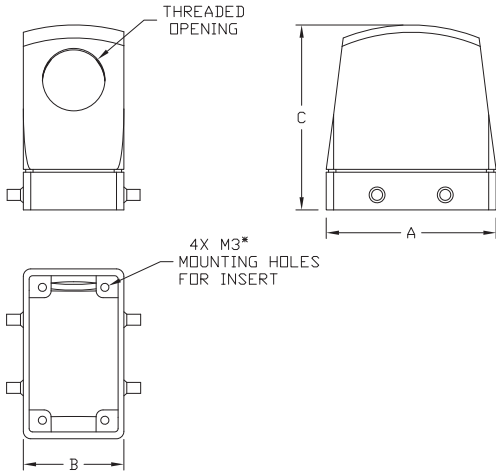

| Part Number | Size | Thread | A | B | C |
|--------------------|------|--------|--------|--------|--------|
| ZP-MC10B-2-DSE21ML | 10B | Pg 21 | 73.5 | 43.5 | 80.0 |
| ZP-MC10B-2-DSE29ML | | Pg 29 | [2.89] | [1.71] | [3.15] |
| ZP-MC16B-2-DSE21ML | 16B | Pg 21 | 94.0 | 43.5 | 80.0 |
| ZP-MC16B-2-DSE29ML | | Pg 29 | [3.70] | [1.71] | [3.15] |
| ZP-MC24B-2-DSE21ML | 24B | Pg 21 | 120.5 | 43.5 | 80.0 |
| ZP-MC24B-2-DSE29ML | | Pg 29 | [4.74] | [1.71] | [3.15] |
| ZP-MC10B-2-DSE36M | 32B* | Pg 36 | 94.0 | 83.0 | 94.0 |
| | | | [3.70] | [3.27] | [3.70] |

*Note: Size 32B hoods require 2 of the 16B inserts.

Double Lever Double Top Entry Hood High Construction

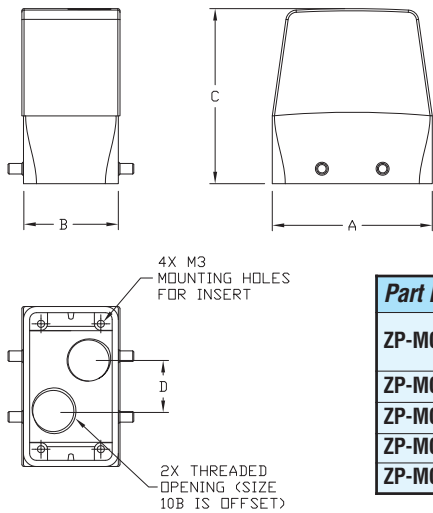

| Part Number | Size | Thread | A | B | C | D |
|--------------------|------|-----------|--------|--------|--------|--------|
| ZP-MC10B-2-DTE13M2 | 10B | Pg 13.5x2 | 73.5 | 43.5 | 81.0 | 24.0 |
| | | | [2.89] | [1.71] | [3.19] | [0.94] |
| ZP-MC16B-2-DTE16M2 | 16B | Pg 16x2 | 94.0 | 43.5 | 81.0 | 38.0 |
| ZP-MC16B-2-DTE21M2 | | Pg 21x2 | [3.70] | [1.71] | [3.19] | [1.50] |
| ZP-MC24B-2-DTE21M2 | 24B | Pg 21x2 | 120.5 | 43.5 | 81.0 | 53.0 |
| ZP-MC24B-2-DTE29M2 | | Pg 29x2 | [4.74] | [1.71] | [3.19] | [2.09] |



STD Series Multi-Wire Dimensions

Size 6B, 10B, 16B, 24B, 32B Bases

Dimensions mm [in]

Single Lever Surface Mount Base

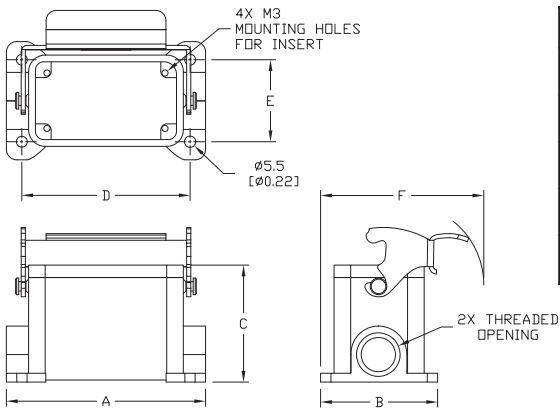

| Part Number | Size | Thread | A | B | C | D | E | F |
|-------------------|------|---------|-----------------|----------------|----------------|-----------------|----------------|-----------------|
| ZP-MC06B-2-SSM16M | 6B | Pg 16x2 | 83.5 [3.29] | 57.0 [2.24] | 53.0 [2.09] | 70.0 [2.76] | 40.0 [1.57] | 79.5 [3.13] |
| ZP-MC10B-2-SSM16M | 10B | Pg 16x2 | 97.0 [3.82] | 57.0 [2.24] | 57.0 [2.24] | 82.0 [3.23] | 40.0 [1.57] | 79.5 [3.13] |
| ZP-MC16B-2-SSM21M | 16B | Pg 21x2 | 117.0 [4.61] | 57.0 [2.24] | 63.0 [2.48] | 105.0 [4.13] | 45.0 [1.77] | 79.5 [3.13] |
| ZP-MC24B-2-SSM21M | 24B | Pg 21x2 | 143.5 [5.65] | 57.0 [2.24] | 63.0 [2.48] | 132.0 [5.20] | 45.0 [1.77] | 79.5 [3.13] |
| ZP-MC32B-2-SSM36M | 32B | Pg 36x2 | 125.0 [4.92] | 84.5 [3.33] | 87.5 [3.44] | 112.0 [4.41] | 67.0 [2.64] | 115.5 [4.55] |

Single Lever High Construction Surface Mount Base

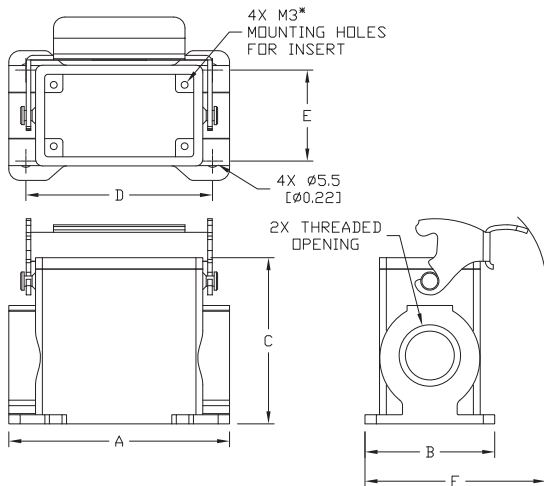

| Part Number | Size | Thread | A | B | C | D | E | F |
|--------------------|------|---------|-----------------|----------------|----------------|-----------------|----------------|----------------|
| ZP-MC06B-2-SSM21ML | 6B | Pg 21x2 | 83.5 [3.29] | 57.0 [2.24] | 72.0 [2.84] | 70.0 [2.76] | 40.0 [1.57] | 79.5 [3.13] |
| ZP-MC06B-2-SSM29ML | | Pg 29x2 | | | | | | |
| ZP-MC10B-2-SSM21ML | 10B | Pg 21x2 | 97.0 [3.82] | 57.0 [2.24] | 73.0 [2.88] | 82.0 [3.23] | 40.0 [1.57] | 79.5 [3.13] |
| ZP-MC10B-2-SSM29ML | | Pg 29x2 | | | | | | |
| ZP-MC16B-2-SSM21ML | 16B | Pg 21x2 | 117.0 [4.61] | 57.0 [2.24] | 77.0 [3.03] | 105.0 [4.13] | 45.0 [1.77] | 79.5 [3.13] |
| ZP-MC16B-2-SSM29ML | | Pg 29x2 | | | | | | |
| ZP-MC24B-2-SSM21ML | 24B | Pg 21x2 | 143.5 [5.65] | 57.0 [2.24] | 80.0 [3.15] | 132.0 [5.20] | 45.0 [1.77] | 79.5 [3.13] |
| ZP-MC24B-2-SSM29ML | | Pg 29x2 | | | | | | |

Single Lever Surface Mount Base With Cover

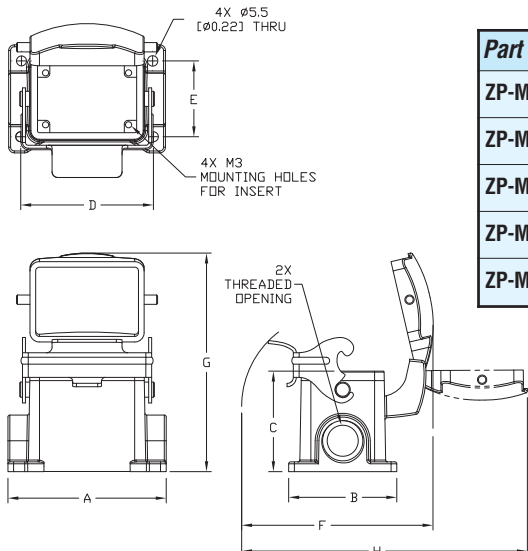

| Part Number | Size | Thread | A | B | C | D | E | F | G | H |
|-------------------|------|---------|-----------------|----------------|----------------|-----------------|----------------|-----------------|-----------------|-----------------|
| ZP-MC06B-2-SSM16C | 6B | Pg 16x2 | 83.5 [3.29] | 57.0 [2.24] | 53.0 [2.09] | 70.0 [2.76] | 40.0 [1.57] | 101.0 [3.98] | 115.3 [4.54] | 150.7 [5.93] |
| ZP-MC10B-2-SSM16C | 10B | Pg 16x2 | 97.0 [3.82] | 57.0 [2.24] | 57.0 [2.24] | 82.0 [3.23] | 40.0 [1.57] | 101.0 [3.98] | 115.3 [4.54] | 145.5 [5.73] |
| ZP-MC16B-2-SSM21C | 16B | Pg 21x2 | 117.0 [4.61] | 57.0 [2.24] | 63.0 [2.48] | 105.0 [4.13] | 45.0 [1.77] | 101.0 [3.98] | 124.5 [4.90] | 145.5 [5.73] |
| ZP-MC24B-2-SSM21C | 24B | Pg 21x2 | 143.5 [5.65] | 57.0 [2.24] | 63.0 [2.48] | 132.0 [5.20] | 45.0 [1.77] | 101.0 [3.98] | 124.5 [4.90] | 145.5 [5.73] |
| ZP-MC32B-2-SSM36C | 32B | Pg 36x2 | 125.0 [4.92] | 84.5 [3.33] | 87.5 [3.44] | 112.0 [4.41] | 67.0 [2.64] | 146.0 [5.75] | 187.0 [7.36] | 228.9 [9.01] |



STD Series Multi-Wire Dimensions

Size 6B, 10B, 16B, 24B, 32B Bases

Dimensions mm [in]

Single Lever High Construction Surface Mount Base With Cover

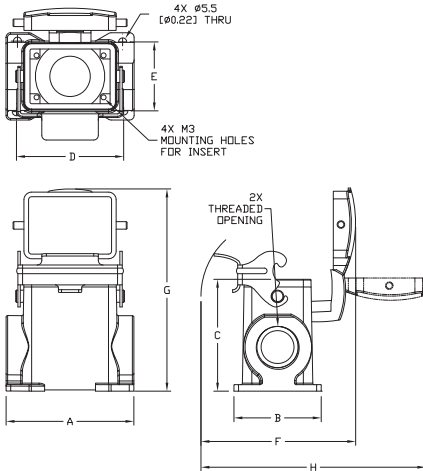

| Part Number | Size | Thread | A | B | C | D | E | F | G | H |
|--------------------|------|---------|--------|--------|--------|--------|--------|--------|--------|--------|
| ZP-MC06B-2-SSM21CL | 6B | Pg 21x2 | 83.5 | 57.0 | 73.0 | 70.0 | 45.0 | 101.0 | 132.1 | 146.8 |
| ZP-MC06B-2-SSM29CL | | Pg 29x2 | [3.29] | [2.24] | [2.87] | [2.76] | [1.77] | [3.98] | [5.20] | [5.78] |
| ZP-MC10B-2-SSM21CL | 10B | Pg 21x2 | 97.0 | 57.0 | 73.0 | 82.0 | 45.0 | 101.0 | 133.3 | 148.0 |
| ZP-MC10B-2-SSM29CL | | Pg 29x2 | [3.82] | [2.24] | [2.87] | [3.23] | [1.77] | [3.98] | [5.25] | [5.83] |
| ZP-MC16B-2-SSM21CL | 16B | Pg 21x2 | 117.0 | 57.0 | 77.0 | 105.0 | 45.0 | 101.0 | 137.5 | 150.0 |
| ZP-MC16B-2-SSM29CL | | Pg 29x2 | [4.61] | [2.24] | [3.03] | [4.13] | [1.77] | [3.98] | [5.41] | [5.91] |
| ZP-MC24B-2-SSM21CL | 24B | Pg 21x2 | 143.5 | 57.0 | 80.0 | 132.0 | 45.0 | 101.0 | 140.5 | 154.4 |
| ZP-MC24B-2-SSM29CL | | Pg 29x2 | [5.65] | [2.24] | [3.15] | [5.20] | [1.77] | [3.98] | [5.53] | [6.08] |

Single Lever Surface Mount Base With Automatic Cover

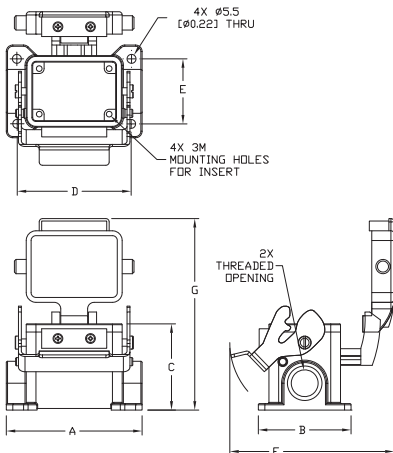

| Part Number | Size | Thread | A | B | C | D | E | F | G |
|--------------------|------|---------|-------|------|------|-------|------|-------|-------|
| ZP-MC06B-2-SSM16CA | 6B | Pg 16x2 | 83.5 | 57.0 | 53.0 | 70.0 | 40.0 | 101.0 | 117.8 |
| ZP-MC10B-2-SSM16CA | 10B | Pg 16x2 | 97.0 | 57.0 | 57.0 | 82.0 | 40.0 | 101.0 | 121.0 |
| ZP-MC16B-2-SSM21CA | 16B | Pg 21x2 | 117.0 | 57.0 | 63.0 | 105.0 | 45.0 | 101.0 | 127.5 |
| ZP-MC24B-2-SSM21CA | 24B | Pg 21x2 | 143.5 | 57.0 | 63.0 | 132.0 | 45.0 | 101.0 | 127.8 |

Single Lever High Construction Surface Mount Base With Automatic Cover

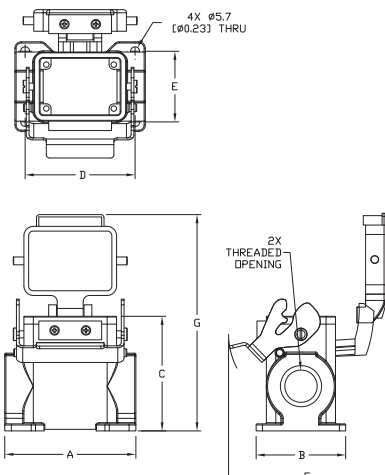

| Part Number | Size | Thread | A | B | C | D | E | F | G |
|--------------------|------|---------|--------|--------|--------|--------|--------|--------|--------|
| ZP-MC06B-2-SSM21CA | 6B | Pg 21x2 | 83.5 | 57.0 | 73.0 | 70.0 | 45.0 | 101.0 | 137.3 |
| ZP-MC06B-2-SSM29CA | | Pg 29x2 | [3.29] | [2.24] | [2.87] | [2.76] | [1.77] | [3.98] | [5.41] |
| ZP-MC10B-2-SSM21CA | 10B | Pg 21x2 | 97.0 | 57.0 | 73.0 | 82.0 | 45.0 | 101.0 | 137.3 |
| ZP-MC10B-2-SSM29CA | | Pg 29x2 | [3.82] | [2.24] | [2.87] | [3.23] | [1.77] | [3.98] | [5.41] |
| ZP-MC16B-2-SM21CAL | 16B | Pg 21x2 | 117.0 | 57.0 | 77.0 | 105.0 | 45.0 | 101.0 | 141.7 |
| ZP-MC16B-2-SM29CAL | | Pg 29x2 | [4.61] | [2.24] | [3.03] | [4.13] | [1.77] | [3.98] | [5.58] |
| ZP-MC24B-2-SM21CAL | 24B | Pg 21x2 | 143.5 | 57.0 | 80.0 | 132.0 | 45.0 | 101.0 | 144.8 |
| ZP-MC24B-2-SM29CAL | | Pg 29x2 | [5.65] | [2.24] | [3.15] | [5.20] | [1.77] | [3.98] | [5.70] |

ZIP^{port} STD Series Multi-Wire Dimensions

Size 6B, 10B, 16B, 24B, 32B Bases

Dimensions mm [in]

Single Lever Bulkhead Base

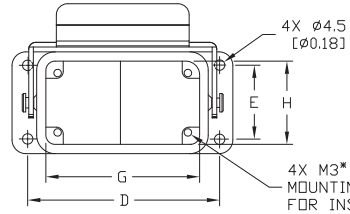

| Part Number | Size | A | B | C | D | E | F | G* | H* |
|-----------------|------|--------------|-------------|-------------|--------------|-------------|--------------|--------------|-------------|
| ZP-MC06B-2-SBHM | 6B | 82.0 [3.23] | 44.0 [1.73] | 29.5 [1.16] | 70.0 [2.75] | 32.0 [1.26] | 73.0 [2.88] | 53.0 [2.09] | 36.0 [1.42] |
| ZP-MC10B-2-SBHM | 10B | 95.5 [3.76] | 44.0 [1.73] | 29.5 [1.16] | 83.0 [3.27] | 32.0 [1.26] | 73.0 [2.88] | 66.5 [2.62] | 36.0 [1.42] |
| ZP-MC16B-2-SBHM | 16B | 115.5 [4.55] | 44.0 [1.73] | 29.5 [1.16] | 103.0 [4.06] | 32.0 [1.26] | 73.0 [2.88] | 86.5 [3.41] | 36.0 [1.42] |
| ZP-MC24B-2-SBHM | 24B | 142.5 [5.61] | 44.0 [1.73] | 29.5 [1.16] | 130.0 [5.12] | 32.0 [1.26] | 73.0 [2.88] | 113.0 [4.45] | 36.0 [1.42] |
| ZP-MC32B-2-SBHM | 32B | 124.5 [4.90] | 84.5 [3.33] | 35.5 [1.40] | 110.0 [4.33] | 65.0 [2.56] | 116.0 [4.57] | 87.5 [3.44] | 76.5 [3.01] |

*Dimensions G and H refer to cutout size

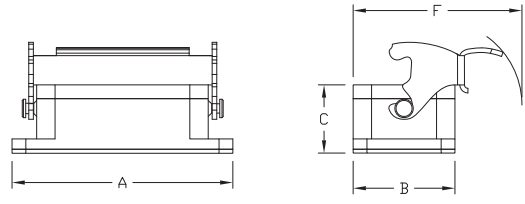

Single Lever Bulkhead Base w/Cover

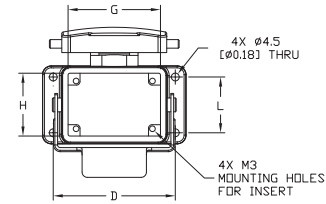

| Part Number | Size | A | B | C | D | E | F | G | H | J |
|-----------------|------|--------------|-------------|-------------|--------------|-------------|--------------|--------------|-------------|--------------|
| ZP-MC06B-2-SBHC | 6B | 82.0 [3.23] | 44.0 [1.73] | 29.5 [1.16] | 70.0 [2.75] | 32.0 [1.26] | 101.0 [3.98] | 53.0 [2.09] | 36.0 [1.42] | 88.5 [3.48] |
| ZP-MC10B-2-SBHC | 10B | 95.5 [3.76] | 44.0 [1.73] | 29.5 [1.16] | 83.0 [3.27] | 32.0 [1.26] | 101.0 [3.98] | 66.5 [2.62] | 36.0 [1.42] | 88.5 [3.48] |
| ZP-MC16B-2-SBHC | 16B | 115.5 [4.55] | 44.0 [1.73] | 29.5 [1.16] | 103.0 [4.06] | 32.0 [1.26] | 101.0 [3.98] | 86.5 [3.41] | 36.0 [1.42] | 88.5 [3.48] |
| ZP-MC24B-2-SBHC | 24B | 142.5 [5.61] | 44.0 [1.73] | 29.5 [1.16] | 130.0 [5.12] | 32.0 [1.26] | 101.0 [3.98] | 113.0 [4.45] | 36.0 [1.42] | 88.5 [3.48] |
| ZP-MC32B-2-SBHC | 32B | 124.5 [4.90] | 84.5 [3.33] | 35.5 [1.40] | 110.0 [4.33] | 65.0 [2.56] | 146.0 [5.75] | 87.5 [3.44] | 76.5 [3.01] | 134.5 [5.30] |

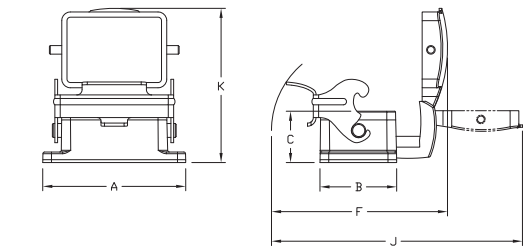

Single Lever Bulkhead Base w/Automatic Cover

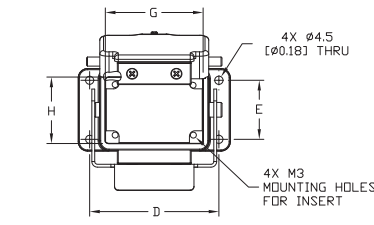

| Part Number | Size | A | B | C | D | E | F | G* | H* | J |
|------------------|------|--------------|-------------|-------------|--------------|-------------|--------------|--------------|-------------|-------------|
| ZP-MC06B-2-SBHCA | 6B | 82.0 [3.23] | 44.0 [1.73] | 29.5 [1.16] | 70.0 [2.75] | 32.0 [1.26] | 101.0 [3.98] | 53.0 [2.09] | 36.0 [1.42] | 97.8 [3.85] |
| ZP-MC10B-2-SBHCA | 10B | 95.5 [3.76] | 44.0 [1.73] | 29.5 [1.16] | 83.0 [3.27] | 32.0 [1.26] | 101.0 [3.98] | 66.5 [2.62] | 36.0 [1.42] | 97.8 [3.85] |
| ZP-MC16B-2-SBHCA | 16B | 115.5 [4.55] | 44.0 [1.73] | 29.5 [1.16] | 103.0 [4.06] | 32.0 [1.26] | 101.0 [3.98] | 86.5 [3.41] | 36.0 [1.42] | 97.8 [3.85] |
| ZP-MC24B-2-SBHCA | 24B | 142.5 [5.61] | 44.0 [1.73] | 29.5 [1.16] | 130.0 [5.12] | 32.0 [1.26] | 101.0 [3.98] | 113.0 [4.45] | 36.0 [1.42] | 97.8 [3.85] |

*Dimensions G and H refer to cutout size

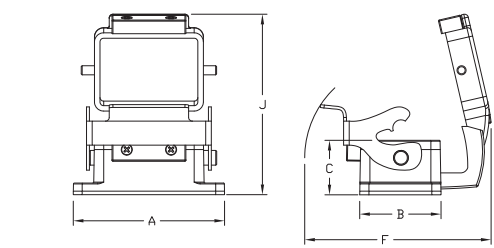



STD Series Multi-Wire Dimensions

Size 10B, 16B, 24B, 32B Bases

Dimensions mm [in]

Double Lever Surface Mount Base

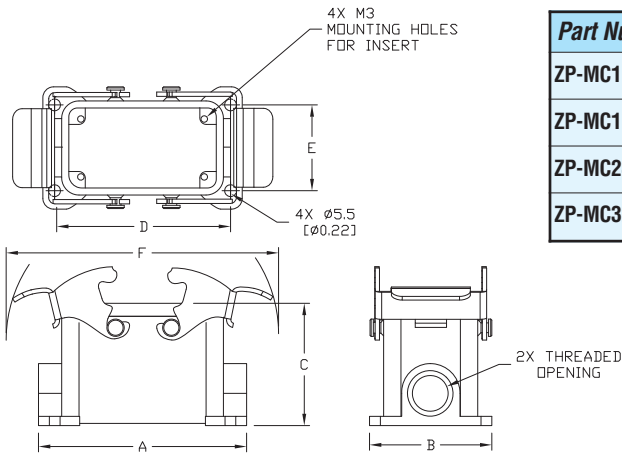

| Part Number | Size | Thread | A | B | C | D | E | F |
|-------------------|------|---------|-----------------|----------------|----------------|-----------------|----------------|-----------------|
| ZP-MC10B-2-DSM16M | 10B | Pg 16x2 | 97.0 [3.82] | 57.0 [2.24] | 57.0 [2.24] | 82.0 [3.23] | 40.0 [1.57] | 127.0 [5.00] |
| ZP-MC16B-2-DSM21M | 16B | Pg 21x2 | 117.0 [4.61] | 57.0 [2.24] | 63.0 [2.48] | 105.0 [4.13] | 45.0 [1.77] | 147.0 [5.79] |
| ZP-MC24B-2-DSM21M | 24B | Pg 21x2 | 143.5 [5.65] | 57.0 [2.24] | 63.0 [2.48] | 132.0 [5.20] | 45.0 [1.77] | 174.0 [6.85] |
| ZP-MC32B-2-DSM36M | 32B | Pg 36x2 | 125.0 [4.92] | 84.5 [3.33] | 87.5 [3.44] | 112.0 [4.41] | 67.0 [2.64] | 147.0 [5.79] |

Double Lever High Construction Surface Mount Base

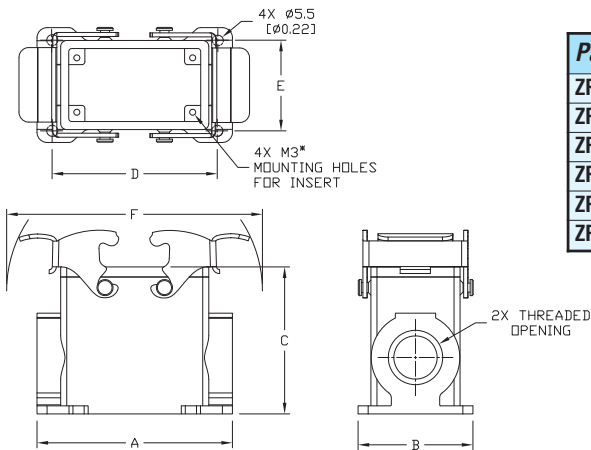

| Part Number | Size | Thread | A | B | C | D | E | F |
|--------------------|------|---------|-----------------|----------------|----------------|-----------------|----------------|-----------------|
| ZP-MC10B-2-DSM21ML | 10B | Pg 21x2 | 97.0 [3.82] | 57.0 [2.24] | 73.0 [2.87] | 82.0 [3.23] | 45.0 [1.77] | 127.0 [5.00] |
| ZP-MC10B-2-DSM29ML | | Pg 29x2 | | | | | | |
| ZP-MC16B-2-DSM21ML | 16B | Pg 21x2 | 117.0 [4.61] | 57.0 [2.24] | 77.0 [3.03] | 105.0 [4.13] | 45.0 [1.77] | 147.0 [5.79] |
| ZP-MC16B-2-DSM29ML | | Pg 29x2 | | | | | | |
| ZP-MC24B-2-DSM21ML | 24B | Pg 21x2 | 143.5 [5.65] | 57.0 [2.24] | 80.0 [3.15] | 132.0 [5.20] | 45.0 [1.77] | 174.0 [6.85] |
| ZP-MC24B-2-DSM29ML | | Pg 29x2 | | | | | | |

Double Lever Bulkhead Base

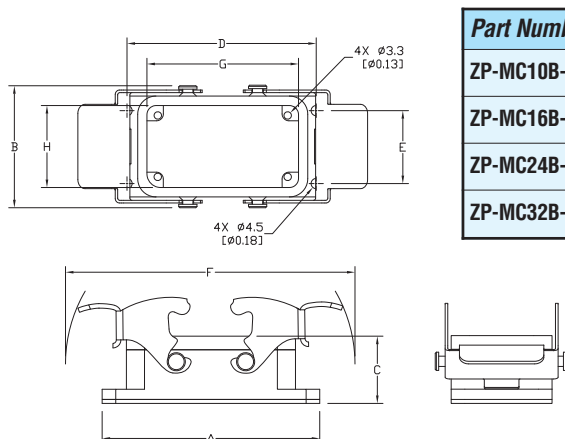

| Part Number | Size | A | B | C | D | E | F | G* | H* |
|-----------------|------|-----------------|----------------|----------------|-----------------|----------------|-----------------|-----------------|----------------|
| ZP-MC10B-2-DBHM | 10B | 95.5 [3.76] | 53.5 [2.11] | 29.5 [1.16] | 83.0 [3.27] | 32.0 [1.26] | 127.0 [5.00] | 66.5 [2.62] | 36.0 [1.42] |
| ZP-MC16B-2-DBHM | 16B | 115.5 [4.55] | 53.5 [2.11] | 29.5 [1.16] | 103.0 [4.05] | 32.0 [1.26] | 147.0 [5.79] | 86.5 [3.41] | 36.0 [1.42] |
| ZP-MC24B-2-DBHM | 24B | 142.5 [5.61] | 53.5 [2.11] | 29.5 [1.16] | 130.0 [5.19] | 32.0 [1.26] | 174.0 [6.85] | 113.0 [4.45] | 36.0 [1.42] |
| ZP-MC32B-2-DBHM | 32B | 124.5 [4.90] | 84.5 [3.33] | 35.5 [1.40] | 110.0 [4.33] | 65.0 [2.56] | 147.0 [5.79] | 87.5 [3.44] | 76.5 [3.01] |

*Dimensions G and H refer to cutout size



STD Series Multi-Wire Dimensions

Size 6B, 10B, 16B, 24B, 32B Couplers

Dimensions mm [in]

Single Lever Coupler

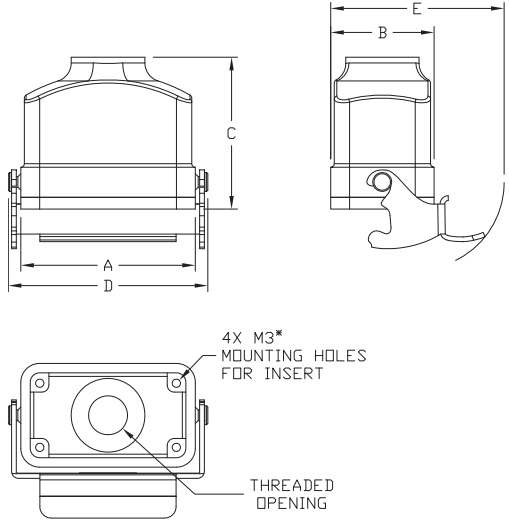

| Part Number | Size | Thread | A | B | C | D | E |
|-------------------|------|--------|-----------------|----------------|----------------|-----------------|----------------|
| ZP-MC06B-2-SCP16M | 6B | Pg 16 | 60.0 [2.36] | 43.5 [1.71] | 59.0 [2.32] | 70.5 [2.78] | 73.0 [2.87] |
| ZP-MC10B-2-SCP16M | 10B | Pg 16 | 73.5 [2.89] | 43.5 [1.71] | 64.0 [2.52] | 84.0 [3.31] | 73.0 [2.87] |
| ZP-MC16B-2-SCP21M | 16B | Pg 21 | 94.0 [3.70] | 43.5 [1.71] | 64.0 [2.52] | 104.0 [4.10] | 73.0 [2.87] |
| ZP-MC24B-2-SCP24M | 24B | Pg 21 | 120.5 [4.74] | 43.5 [1.71] | 74.0 [2.91] | 131.0 [5.16] | 73.0 [2.87] |

Single Lever High Construction Coupler

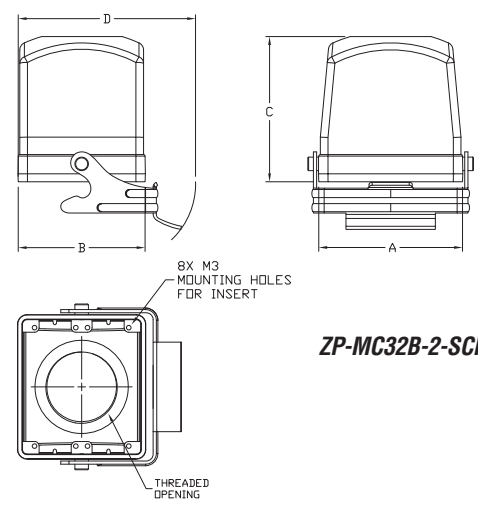

ZP-MC32B-2-SCP36M

| Part Number | Size | Thread | A | B | C | D | E |
|-------------------|------|--------|----------------|----------------|----------------|-----------------|-----------------|
| ZP-MC32B-2-SCP36M | 32B | Pg 36 | 94.0 [3.70] | 83.0 [3.27] | 95.0 [3.74] | 104.5 [4.11] | 116.0 [4.57] |

Double Lever Coupler

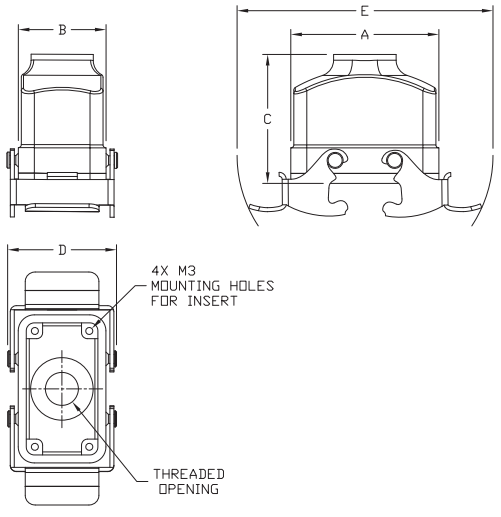

| Part Number | Size | Thread | A | B | C | D | E |
|-------------------|------|--------|-----------------|----------------|----------------|----------------|-----------------|
| ZP-MC10B-2-DCP16M | 10B | Pg 16 | 73.5 [2.89] | 43.5 [1.71] | 64.0 [2.52] | 54.0 [2.13] | 127.0 [5.00] |
| ZP-MC16B-2-DCP21M | 16B | Pg 21 | 94.0 [3.70] | 43.5 [1.71] | 64.0 [2.52] | 54.0 [2.13] | 147.0 [5.79] |
| ZP-MC24B-2-DCP21M | 24B | Pg 21 | 120.5 [4.74] | 43.5 [1.71] | 74.0 [2.91] | 54.0 [2.13] | 174.0 [6.85] |

Double Lever High Construction Coupler

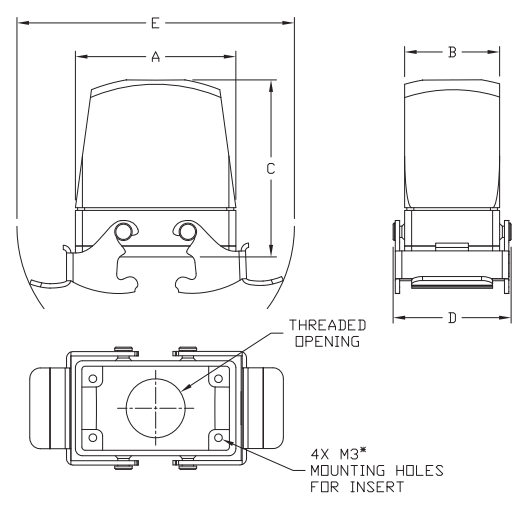

| Part Number | Size | Thread | A | B | C | D | E |
|--------------------|------|--------|-----------------|----------------|----------------|----------------|-----------------|
| ZP-MC10B-2-DCP21ML | 10B | Pg 21 | 73.5 [2.89] | 43.5 [1.71] | 81.0 [3.19] | 54.0 [2.13] | 127.0 [5.00] |
| ZP-MC16B-2-DCP21ML | 16B | Pg 21 | 94.0 [3.70] | 43.5 [1.71] | 81.0 [3.19] | 54.0 [2.13] | 147.0 [5.79] |
| ZP-MC16B-2-DCP29ML | | Pg 29 | | | | | |
| ZP-MC24B-2-DCP21ML | 24B | Pg 21 | 120.5 [4.74] | 43.5 [1.71] | 81.0 [3.19] | 54.0 [2.13] | 174.0 [6.85] |
| ZP-MC24B-2-DCP29ML | | Pg 29 | | | | | |
| ZP-MC32B-2-DCP36M | 32B | Pg 36 | 94.0 [3.70] | 83.0 [3.27] | 95.0 [3.74] | 93.5 [3.68] | 147.0 [5.79] |

* To convert to NPT thread see the adapter in the accessories section



STD Series Multi-Wire Dimensions

Size 6B, 10B, 16B, 24B, 32B Covers

Dimensions mm [in]

Single Lever Cover

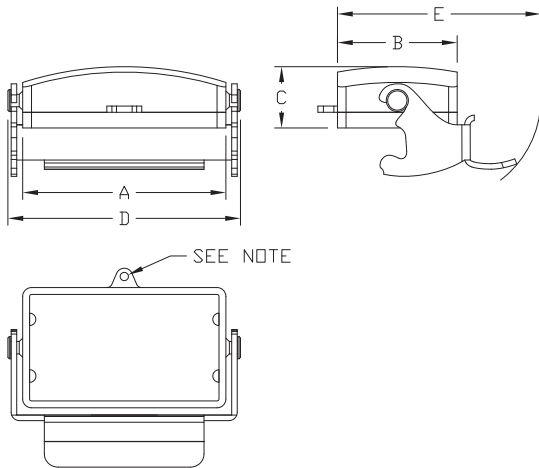

| Part Number | Size | A | B | C | D | E |
|------------------|------|-----------------|----------------|----------------|-----------------|-----------------|
| ZP-MC06B-2-SCVLM | 06B | 60.0 [2.36] | 43.0 [1.69] | 22.0 [0.87] | 70.5 [2.78] | 73.0 [2.87] |
| ZP-MC10B-2-SCVLM | 10B | 73.0 [2.88] | 43.0 [1.69] | 22.0 [0.87] | 83.5 [3.29] | 73.0 [2.87] |
| ZP-MC16B-2-SCVLM | 16B | 94.0 [3.70] | 43.0 [1.69] | 22.0 [0.87] | 104.0 [4.09] | 73.0 [2.87] |
| ZP-MC24B-2-SCVLM | 24B | 120.0 [4.72] | 43.0 [1.69] | 23.0 [0.91] | 130.5 [5.14] | 73.0 [2.87] |
| ZP-MC32B-2-SCVLM | 32B | 94.0 [3.70] | 83.0 [3.27] | 24.0 [0.94] | 104.5 [4.11] | 116.0 [4.57] |

Double Lever Cover

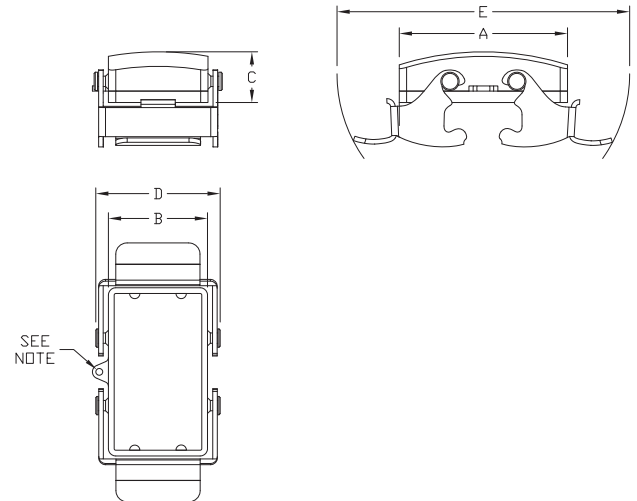

| Part Number | Size | A | B | C | D | E |
|----------------|------|-----------------|----------------|----------------|----------------|-----------------|
| ZP-MC10B-DCVLM | 10B | 73.0 [2.87] | 43.0 [1.69] | 22.0 [0.87] | 54.0 [2.13] | 127.0 [5.00] |
| ZP-MC16B-DCVLM | 16B | 94.0 [3.70] | 43.0 [1.69] | 22.0 [0.87] | 54.0 [2.13] | 147.0 [5.79] |
| ZP-MC24B-DCVLM | 24B | 120.0 [4.72] | 43.0 [1.69] | 23.0 [0.91] | 54.0 [2.13] | 174.0 [6.85] |
| ZP-MC32B-DCVLM | 32B | 94.0 [3.70] | 83.0 [3.27] | 24.0 [0.94] | 93.5 [3.68] | 147.0 [5.79] |

Two Peg Cover

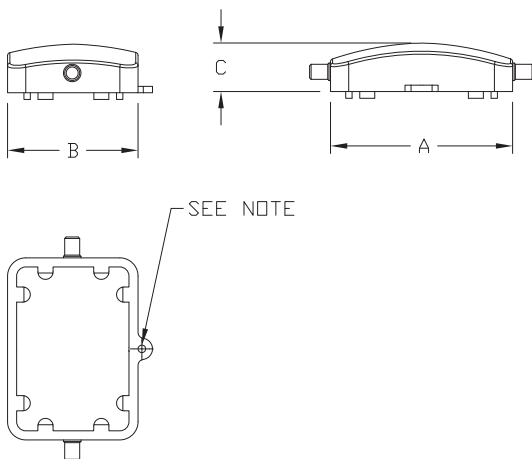

| Part Number | Size | A | B | C |
|------------------|------|-----------------|----------------|----------------|
| ZP-MC06B-2-SCVPM | 6B | 60.0 [2.76] | 43.0 [1.69] | 16.0 [0.63] |
| ZP-MC10B-2-SCVPM | 10B | 73.0 [2.87] | 43.0 [1.69] | 16.0 [0.63] |
| ZP-MC16B-2-SCVPM | 16B | 94.0 [3.70] | 43.0 [1.69] | 16.0 [0.63] |
| ZP-MC24B-2-SCVPM | 24B | 120.0 [4.72] | 43.0 [1.69] | 17.0 [0.67] |
| ZP-MC32B-2-SCVPM | 32B | 94.0 [3.70] | 83.0 [3.27] | 18.0 [0.71] |

Four Peg Cover

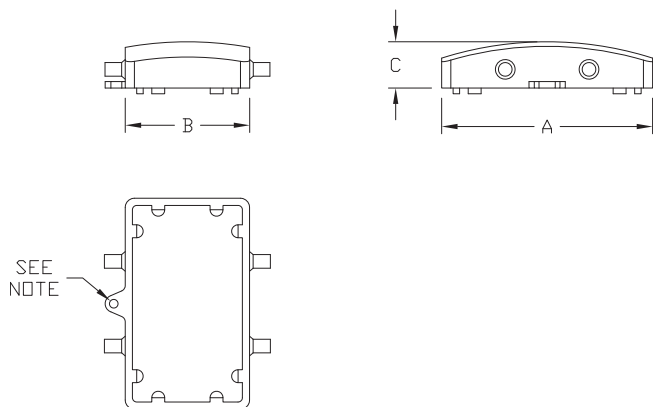

| Part Number | Size | A | B | C |
|------------------|------|-----------------|----------------|----------------|
| ZP-MC10B-2-DCVPM | 10B | 73.0 [2.87] | 43.0 [1.69] | 16.0 [0.63] |
| ZP-MC16B-2-DCVPM | 16B | 94.0 [3.70] | 43.0 [1.69] | 16.0 [0.63] |
| ZP-MC24B-2-DCVPM | 24B | 120.0 [4.72] | 43.0 [1.69] | 17.0 [0.67] |
| ZP-MC32B-2-DCVPM | 32B | 94.0 [3.70] | 83.0 [3.27] | 18.0 [0.71] |

Note: Includes attached 112 mm [4.40 inch] nylon cord with ring terminal

AUTOMATIONDIRECT.com The #1 Value in Automation

2-Day Delivery!

Free on orders
over \$49



Delivery Service**

- 1-Day Ground Service
- 2-Day Ground Service
- 2-Day Air Service

** for items shipped from
Cumming, GA

Get it fast AND free!

Free standard 2-day (transit)* shipping is now available for orders over \$49, within the U.S. and Puerto Rico. We use our choice of carrier and a combination of ground and air services that allow us to reach any U.S. destination within 2 days transit time (or less). (Canadian orders use the same method, but may take longer based on destination.) Orders placed by 6 p.m. EST will ship the same day (with approved company credit or credit card; LTL items require 5 p.m. order cutoff).

Note that the 2-day transit time does not apply for LTL shipping of heavy items or drop-shipped items. (We can ship heavy items to Alaska, Hawaii and Puerto Rico, but they will always incur a shipping charge. To determine if an item must ship LTL, check the "Availability" column of the printed price list.)

For orders under \$49, a flat \$6 shipping charge is applied. Or, you may request that your order ship via the 2-day (transit) method; shipping charges will be added to invoice.

For complete details on shipping methods and charges, see Terms and Conditions or online at our Web site for most up-to-date information.

* We do not guarantee delivery times of the carriers. AutomationDirect is not responsible for carrier delays due to weather, mechanical failures or other issues.



1-800-633-0405 www.automationdirect.com

WE HAVE

CABLES

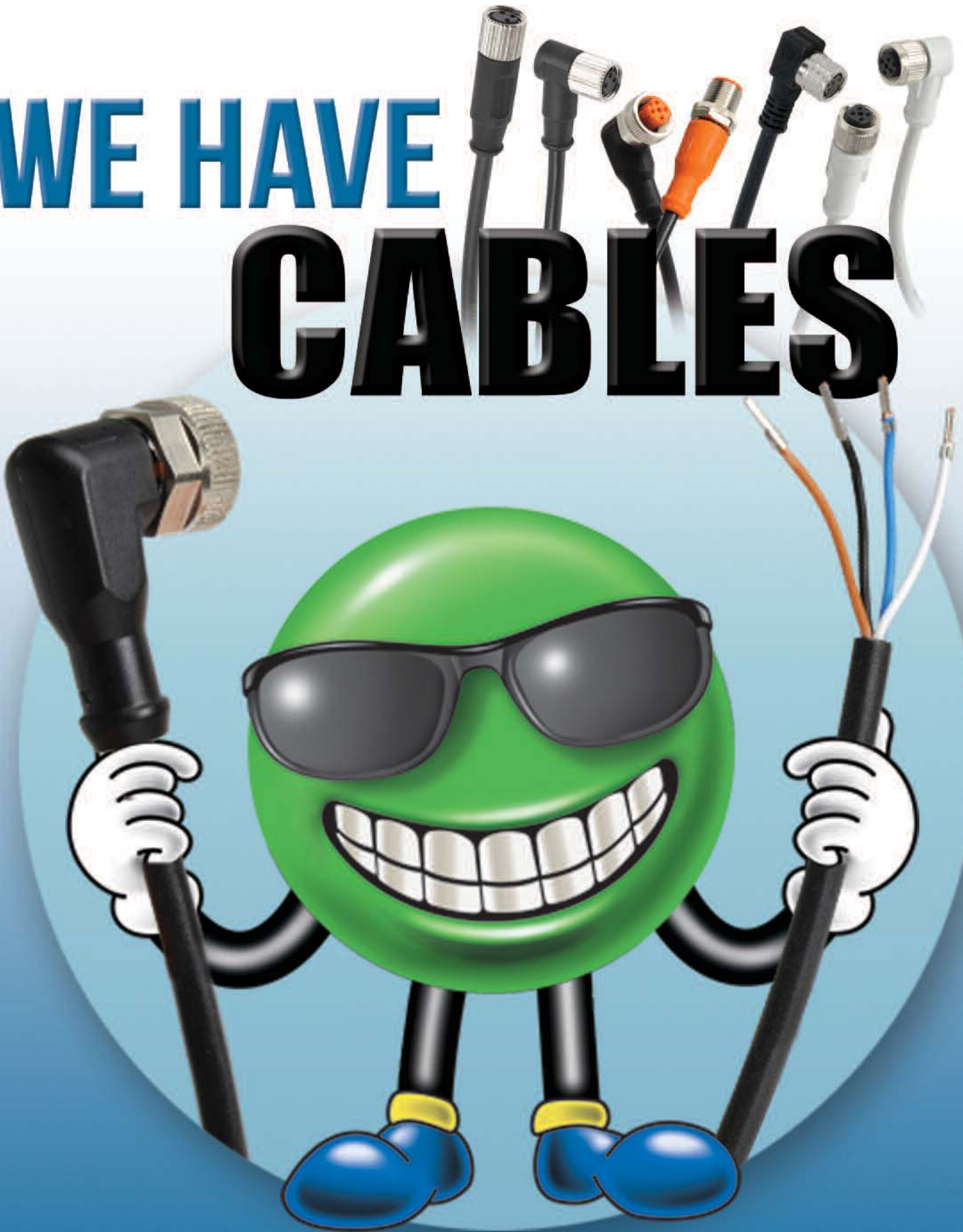

Sensor Cables and Connectors

Cables with quick-disconnect plugs

- Industry standard axial and right-angle M8/M12 screw-lock connectors with open leads. The cables listed can be used with patch cables
- 2m, 3m, 5m, 7m, 10m and 15m cable lengths
- PVC (polyvinyl chloride) jacket for typical industrial applications
- PUR (polyurethane) jacket for oily and direct sunlight applications
- IP67 rated



CD08-0A-020-C1 and -A1 shown



CD08-0A-050-C1 and -A1 shown



CD12L-0B-020-A0 and -C0 shown



CD12M-0B-050-C1 and -A1 shown



7000-12221-2141000



7000-12241-2150500



7000-17041-2951000



7000-19041-7050500

| M8 Quick-Disconnect Cables (Pico, Nano) | | | | | | |
|---|-------|---------------|-------|--------------------|--------|------------|
| Part Number | Price | Length | Poles | Connector | Jacket | Dimensions |
| M8 Quick-Disconnects | | | | | | |
| CD08-0A-020-A1 | <---> | 2m (6.5 ft.) | 3 | Axial female | PVC | Figure 1 |
| CD08-0A-020-C1 | <---> | 2m (6.5 ft.) | 3 | Right-angle female | PVC | Figure 2 |
| CD08-0A-050-A1 | <---> | 5m (16.4 ft.) | 3 | Axial female | PVC | Figure 4 |
| CD08-0C-050-A1 | <---> | 5m (16.4 ft.) | 3 | Axial female | PUR | Figure 3 |
| CD08-0A-050-C1 | <---> | 5m (16.4 ft.) | 3 | Right-angle female | PVC | Figure 5 |
| CD08-0C-050-C1 | <---> | 5m (16.4 ft.) | 3 | Right-angle female | PUR | Figure 5 |
| CD08-0A-070-A1 | <---> | 7m (23 ft.) | 3 | Axial female | PVC | Figure 1 |
| CD08-0A-070-C1 | <---> | 7m (23 ft.) | 3 | Right-angle female | PVC | Figure 2 |

| M12 Quick-Disconnect Cables (Euro, Micro DC-Single Key) | | | | | | |
|---|-------|---------------|-------|--------------------|--------|------------|
| Part Number | Price | Length | Poles | Connector | Jacket | Dimensions |
| M12 Quick-Disconnects | | | | | | |
| CD12M-0B-050-A1* | <---> | 5m (16.4 ft) | 3 | Axial female | PVC | Figure 8 |
| CD12M-0D-050-A1* | <---> | 5m (16.4 ft) | 3 | Axial female | PUR | Figure 9 |
| CD12M-0B-050-C1* | <---> | 5m (16.4 ft) | 3 | Right-angle female | PVC | Figure 10 |
| CD12M-0D-050-C1* | <---> | 5m (16.4 ft) | 3 | Right-angle female | PUR | Figure 11 |
| CD12L-0B-020-A0 | <---> | 2m (6.5 ft) | 4 | Axial female | PVC | Figure 6 |
| CD12L-0B-020-C0 | <---> | 2m (6.5 ft) | 4 | Right-angle female | PVC | Figure 7 |
| CD12M-0B-070-A1 | <---> | 7m (23 ft) | 4 | Axial female | PVC | Figure 6 |
| CD12M-0B-070-C1 | <---> | 7m (23 ft) | 4 | Right-angle female | PVC | Figure 7 |
| 7000-12221-2141000 | <---> | 10m (32.8 ft) | 4 | Axial female | PVC | Figure 13 |
| 7000-12221-2141500 | <---> | 15m (49.2 ft) | 4 | Axial female | PVC | Figure 13 |
| 7000-12341-2141000 | <---> | 10m (32.8 ft) | 4 | Right-angle female | PVC | Figure 14 |
| 7000-12341-2141500 | <---> | 15m (49.2 ft) | 4 | Right-angle female | PVC | Figure 14 |
| 7000-12241-2150300 | <---> | 3m (9.8 ft) | 5 | Axial female | PVC | Figure 15 |
| 7000-12241-2150500 | <---> | 5m (16.4 ft) | 5 | Axial female | PVC | Figure 15 |
| 7000-12241-2151000 | <---> | 10m (32.8 ft) | 5 | Axial female | PVC | Figure 15 |
| 7000-12361-2150300 | <---> | 3m (9.8 ft) | 5 | Right-angle female | PVC | Figure 16 |
| 7000-12361-2150500 | <---> | 5m (16.4 ft) | 5 | Right-angle female | PVC | Figure 16 |
| 7000-12361-2151000 | <---> | 10m (32.8 ft) | 5 | Right-angle female | PVC | Figure 16 |
| 7000-17041-2950300 | <---> | 3m (9.8 ft) | 8 | Axial female | PUR | Figure 17 |
| 7000-17041-2950500 | <---> | 5m (16.4 ft) | 8 | Axial female | PUR | Figure 17 |
| 7000-17041-2951000 | <---> | 10m (32.8 ft) | 8 | Axial female | PUR | Figure 17 |
| 7000-17061-2950300 | <---> | 3m (9.8 ft) | 8 | Right-angle female | PUR | Figure 18 |
| 7000-17061-2950500 | <---> | 5m (16.4 ft) | 8 | Right-angle female | PUR | Figure 18 |
| 7000-17061-2951000 | <---> | 10m (32.8 ft) | 8 | Right-angle female | PUR | Figure 18 |
| 7000-19041-7050300 | <---> | 3m (9.8 ft) | 12 | Axial female | PUR | Figure 19 |
| 7000-19041-7050500 | <---> | 5m (16.4 ft) | 12 | Axial female | PUR | Figure 19 |
| 7000-19041-7051000 | <---> | 10m (32.8 ft) | 12 | Axial female | PUR | Figure 19 |
| 7000-19061-7050300 | <---> | 3m (9.8 ft) | 12 | Right-angle female | PUR | Figure 20 |
| 7000-19061-7050500 | <---> | 5m (16.4 ft) | 12 | Right-angle female | PUR | Figure 20 |
| 7000-19061-7051000 | <---> | 10m (32.8 ft) | 12 | Right-angle female | PUR | Figure 20 |

* Note: Do not use with sensors that require 4-pole cables.

Sensor Cables and Connectors

Shielded M12 Cables with quick-disconnect plugs



7000-17121-2941000



7000-17141-2940500

- Industry standard axial and right-angle M12 screw-lock connectors with open leads
- Braided shield located inside the cord jacket and connected to the coupling nut
- 5m and 10m cable lengths
- PUR (polyurethane) jacket for oily and direct sunlight applications
- IP67 rated

| Shielded M12 Quick-Disconnect Cables (Euro, Micro DC-Single Key) | | | | | | |
|--|-------|---------------|-------|--------------------|--------|------------|
| Part Number | Price | Length | Poles | Connector | Jacket | Dimensions |
| M12 Quick-Disconnects (shielded) | | | | | | |
| 7000-13201-3310500 | <--> | 5m (16.4 ft) | 4 | Axial female | PUR | Figure 21 |
| 7000-13201-3311000 | <--> | 10m (32.8 ft) | 4 | Axial female | PUR | Figure 21 |
| 7000-13261-3310500 | <--> | 5m (16.4 ft) | 4 | Right-angle female | PUR | Figure 22 |
| 7000-13261-3311000 | <--> | 10m (32.8 ft) | 4 | Right-angle female | PUR | Figure 22 |
| 7000-13221-3490500 | <--> | 5m (16.4 ft) | 5 | Axial female | PUR | Figure 23 |
| 7000-13221-3491000 | <--> | 10m (32.8 ft) | 5 | Axial female | PUR | Figure 23 |
| 7000-13281-3490500 | <--> | 5m (16.4 ft) | 5 | Right-angle female | PUR | Figure 24 |
| 7000-13281-3491000 | <--> | 10m (32.8 ft) | 5 | Right-angle female | PUR | Figure 24 |
| 7000-17121-2940500 | <--> | 5m (16.4 ft) | 8 | Axial female | PUR | Figure 25 |
| 7000-17121-2941000 | <--> | 10m (32.8 ft) | 8 | Axial female | PUR | Figure 25 |
| 7000-17141-2940500 | <--> | 5m (16.4 ft) | 8 | Right-angle female | PUR | Figure 26 |
| 7000-17141-2941000 | <--> | 10m (32.8 ft) | 8 | Right-angle female | PUR | Figure 26 |

Cables with LED and quick-disconnect plugs

- Industry standard M12 right angle female-plug with open leads
- These cables can be used with patch cables.
- 2m, 5m and 10m cable lengths

- PUR (polyurethane) jacket for oily and direct sunlight applications
- IP67 /IP68 / IP69K, II rated
- LED indication for 10-36 VDC PNP sensors only

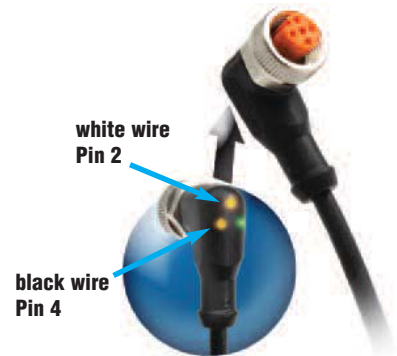

| M12 Quick-Disconnect Cables with LED Indicator (Euro, Micro DC-Single Key) | | | | | | | |
|--|-------|---------------|-------|--------------------|-----|--------|------------|
| Part Number | Price | Length | Poles | Connector | LED | Jacket | Dimensions |
| M12 Quick-Disconnects | | | | | | | |
| EVC178* | <--> | 2m (6.5 ft) | 4 | Right-angle female | Yes | PUR | Figure 12 |
| EVC179* | <--> | 5m (16.4 ft) | 4 | Right-angle female | Yes | PUR | Figure 12 |
| EVC180* | <--> | 10m (32.8 ft) | 4 | Right-angle female | Yes | PUR | Figure 12 |

**Note: LED for 10 to 36 VDC PNP devices only.
Do not use with NPN or analog output devices.
Do not use when white wire (Pin 2) is used for selection of a sensor function.
Do not use when emitter has check function.*

LED Models' Wiring

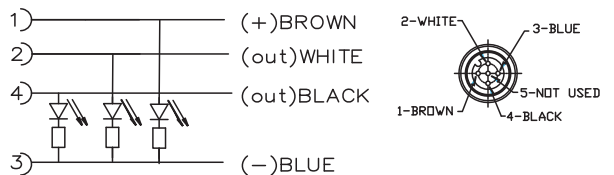

Sensor Cables and Connectors

| Cable Specifications | | | | | |
|---|--|-------------------------------|-------------------------------|--|--|
| Specification | M8 | | M12 | | |
| | | | CD Series | | 7000 Series (unshielded) |
| Length | 2m (6.5 ft) / 7m (23 ft) | 5m (16.4 ft) | 2m (6.5 ft) / 7m (23 ft) | 5m (16.4 ft) | 3m (9.8 ft) / 5m (16.4 ft) / 10m (32.8 ft) / 15m (49.2 ft) |
| Nominal Voltage | 50 VAC/75 VDC | 60 VAC/VDC | 250 VAC/VDC | | 30 VAC/VDC; 125 VAC/VDC; 250 VAC/VDC |
| Max Current | 4A | | 4A | | 3/4 pin: 250 VAC/VDC, 4A 5 pin: 125 VAC/VDC, 4A 8 pin: 30 VAC/VDC, 2A 12 pin: 30 VAC/VDC, 1.5A |
| LED Current Loading | N/A | | | | |
| Protection Degree | IP67 | IP65 / IP68 / IP69K | IP67 | PVC: IP68 PUR: IP68 / IP69K | IP67 |
| Material Nut | Nickel plated brass | | | | Nickel plated Zinc |
| Housing Material | Polyurethane (PUR) or Polyvinyl-chloride (PVC) | | | | |
| Contacts Material | Gold plated Copper-Tin Alloy (CuSn) | | | | Gold plated brass |
| Tightening Torque | 0.5 Nm | ≤ 0.4 Nm | 0.5 Nm | ≤ 0.4 Nm | 0.6 Nm |
| Conductors Cross Section (AWG) | 0.25 mm ² (24 AWG) | 0.25 mm ² (24 AWG) | 0.25 mm ² (24 AWG) | 0.34 mm ² (22 AWG) | 4 x 0.34 mm ² (4 x 22 AWG) 5 x 0.34 mm ² (5 x 22 AWG) 8 x 0.25 mm ² (8 x 24 AWG) 12 x 0.14 mm ² (12 x 26 AWG) |
| Ø Outer Cable | 5mm | PVC: 4mm PUR: 4mm | 5mm | PVC: 4.2 mm PUR: 4.3 mm | PVC: 5 - 5.2 mm PUR: 6.0 mm |
| Temperature Range | -25° to +80°C (-13° to 176°F) | -25° to 90°C (-13° to 194°F) | -25° to +80°C (-13° to 176°F) | PVC: -30° to 70°C (-22° to 158°F) PUR: -50° to 90°C (-58° to 194°F) | PVC: -25° to +70°C (-13° to 158°F) PUR: -25° to +85°C (-13° to 185°F) |
| Environmental | N/A | Halogen/Silicone free | N/A | Halogen/Silicone free | N/A |
| Function Display Power LED | N/A | | | | |
| Switching Status LED | N/A | | | | |
| Drag Chain (Roller Cable Tray) Suitability | Bending Radius | min. 10 x cable diameter | | | |
| | Bending Cycles | N/A | | | |
| | Travel Speed | N/A | | | |
| | Torsional Strain | N/A | | | |
| Agency Approvals | RoHS | | | | RoHS (UL E325311 8/12 pole) |

Company Information

Systems Overview

Programmable Controllers

Field I/O

Software

C-more & other HMI

Drives

Soft Starters

Motors & Gearbox

Steppers/ Servos

Motor Controls

Proximity Sensors

Photo Sensors

Limit Switches

Encoders

Current Sensors

Pressure Sensors

Temperature Sensors

Pushbuttons/ Lights

Process

Relays/ Timers

Comm.

Terminal Blocks & Wiring

Power

Circuit Protection

Enclosures

Tools

Pneumatics

Safety

Appendix

Product Index

Part # Index

Sensor Cables and Connectors

| Cable Specifications | | |
|--|---|---|
| Specification | M12 7000 Series (shielded) | M12 with LED |
| Length | 5m (16.4 ft) / 10m (32.8 ft) | 2m (6.5 ft) / 5m (16.4 ft) / 10m (32.8 ft) |
| Nominal Voltage | 30 VAC/VDC / 60 VAC/VDC | 10 to 36 VDC |
| Max Current | 2A / 4A | 4A |
| LED Current Loading | N/A | 10 V input Brown wire LED: 1.7 mA White and/or Black LED: 0.9 mA 36V input Brown wire LED: 7.3 mA White and/or Black LED: 4.7 mA |
| Protection Degree | IP67 | IP67 / IP68 / IP69K |
| Material Nut | Nickel plated Zinc | Nickel plated Brass |
| Jacket Material | Polyurethane (PUR) | |
| Housing Material | Polyurethane (PUR) | |
| Contacts Material | Gold plated Brass | |
| Tightening Torque | 0.6 Nm | 0.6 to 1.5 Nm |
| Conductors Cross Section (AWG) | 4 x 0.34 mm ² (4 x 22 AWG) 5 x 0.34 mm ² (5 x 22 AWG) 8 x 0.25 mm ² (8 x 24 AWG) | 4 x 0.34 mm ² (4 x 22 AWG) |
| Ø Outer Cable | 4/5 pole: 5.9 mm 8 pole: 7mm | 5mm |
| Temperature Range | -25° to +80°C (-13° to 176°F) | -25° to +90°C (-13° to 194°F) |
| Function Display Power LED | N/A | Green |
| Switching Status LED | N/A | 2 x Yellow |
| Drag Chain (Roller Cable Tray) Suitability | Bending Radius | min. 10 x cable diameter |
| | Bending Cycles | N/A |
| | Travel Speed | N/A |
| | Torsional Strain | N/A |
| Agency Approvals | RoHS | UL File E191684, RoHS |

| UL Reference | |
|---|--|
| Part Number | Mini-Series Female Cord Connectors Series M12, UL Catalog Number |
| EVC178 | ADOAH043MSS0002H04 |
| EVC179 | ADOAH043MSS0005H04 |
| EVC180 | ADOAH043MSS0010H04 |
| <i>Note: Shown in UL file under Mini-series Female Cord Connectors using catalog number</i> | |

Sensor Cables and Connectors

Dimensions

mm [inches]

Figure 1

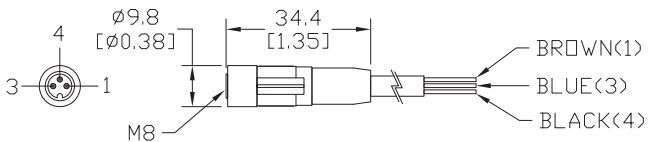

Figure 2

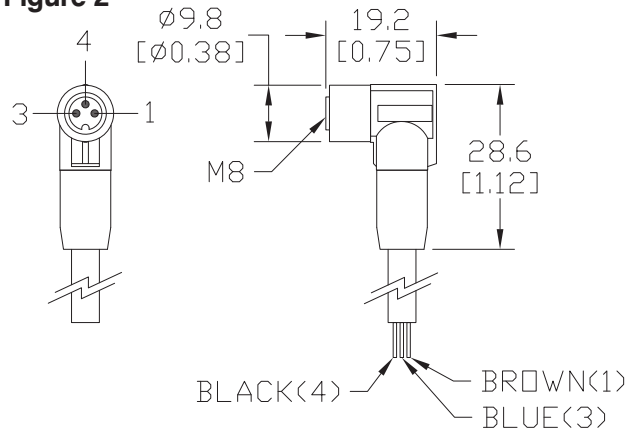

Figure 3

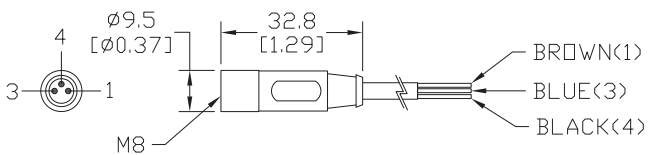

Figure 4

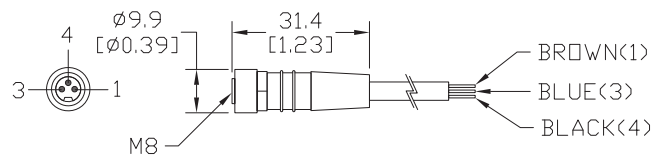

Figure 5

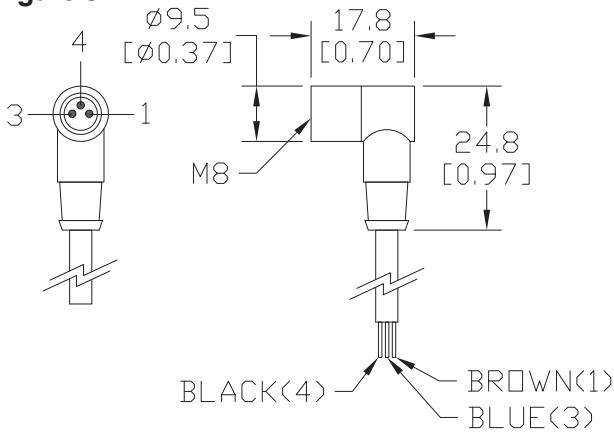

Figure 6

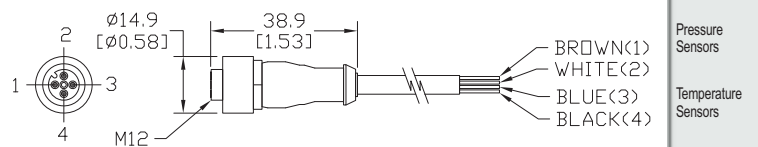

Figure 7

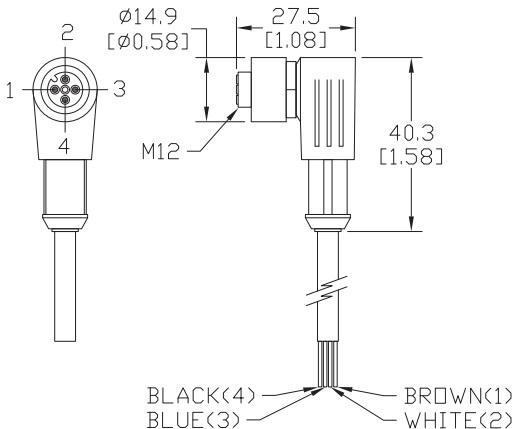
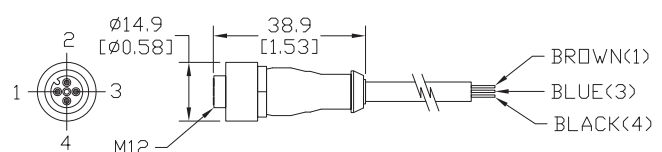

Figure 8



Sensor Cables and Connectors

Dimensions

mm [inches]

Figure 9

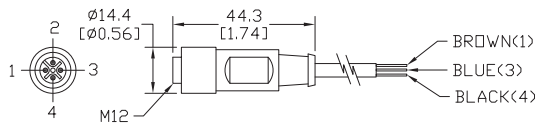

Figure 10

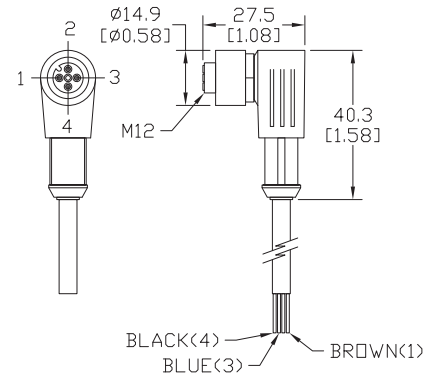

Figure 11

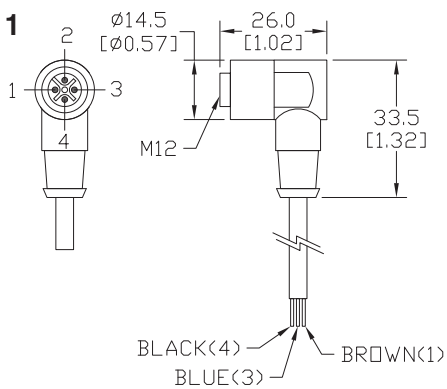

Figure 12

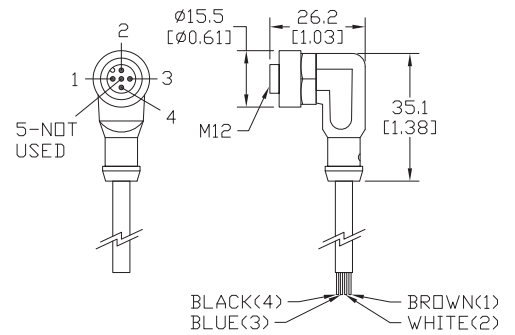

Figure 13

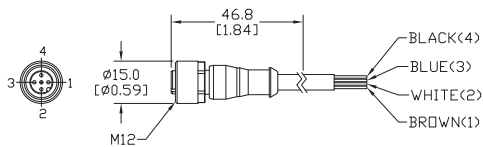

Figure 14

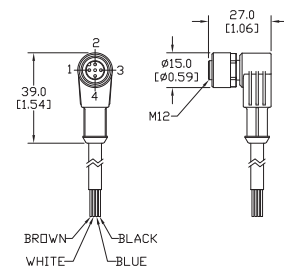

Figure 15

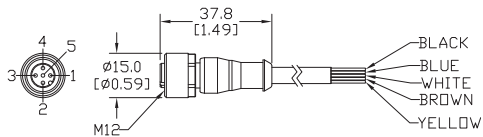
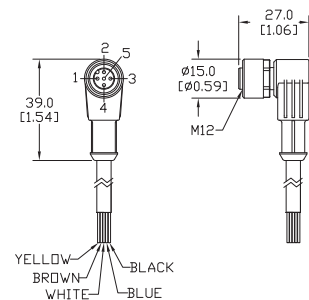

Figure 16



Sensor Cables and Connectors

Dimensions

mm [inches]

Figure 17

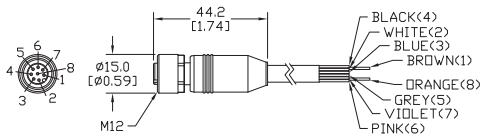

Figure 18

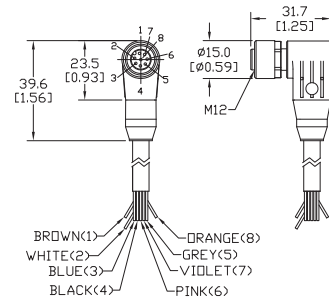

Figure 19

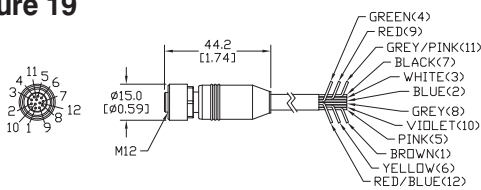

Figure 20

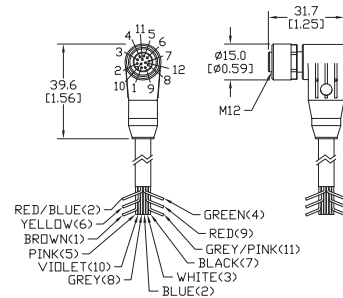

Figure 21

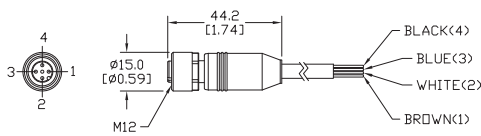

Figure 22

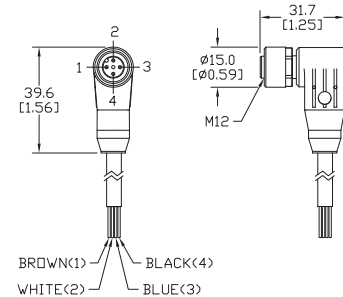

Figure 23

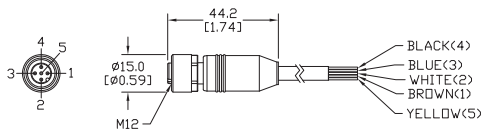

Figure 24

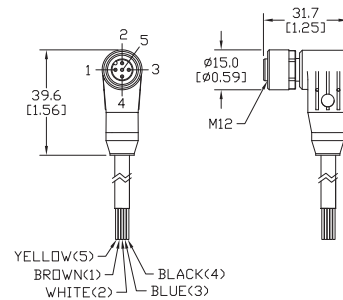

Figure 25

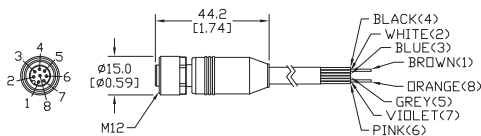
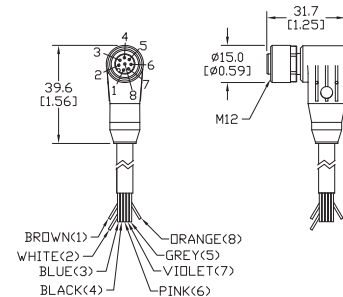

Figure 26



Sensor Cables and Connectors

Patch cables with quick-disconnect plugs on each end



Available patch cables include:

- Industry standard M8 and M12 screw-lock connectors
- One male and one female connector

- Axial and right-angle connector models
- 1m and 3m cable lengths
- PVC (polyvinyl chloride) jacket for typical industrial applications
- IP67 rated

| M8 Patch Cables with Quick-Disconnect on Each End (Pico, Nano) | | | | | | |
|--|-------|--------------|-------|---|--------|------------|
| Part Number | Price | Length | Poles | Connectors | Jacket | Dimensions |
| M8 Quick-Disconnect Patch Cables | | | | | | |
| CDP08-0A-010-AA | <--> | 1m (3.28 ft) | 3 | 2 Axial - One male and one female connector | PVC | Figure 1 |
| CDP08-0A-010-BB | <--> | 1m (3.28 ft) | 3 | 2 Right-angle - One male and one female connector | PVC | Figure 3 |
| CDP08-0A-030-AA | <--> | 3m (9.84 ft) | 3 | 2 Axial - One male and one female connector | PVC | Figure 2 |
| CDP08-0A-030-BB | <--> | 3m (9.84 ft) | 3 | 2 Right-angle - One male and one female connector | PVC | Figure 3 |

| M12 Patch Cables with Quick-Disconnect on Each End (Euro, Micro DC-Single Key) | | | | | | |
|--|-------|--------------|-------|---|--------|------------|
| Part Number | Price | Length | Poles | Connectors | Jacket | Dimensions |
| M12 Quick-Disconnect Patch Cables | | | | | | |
| CDP12-0B-010-AA | <--> | 1m (3.28 ft) | 4 | 2 Axial - One male and one female connector | PVC | Figure 4 |
| CDP12-0B-010-BB | <--> | 1m (3.28 ft) | 4 | 2 Right-angle - One male and one female connector | PVC | Figure 5 |
| CDP12-0B-030-AA | <--> | 3m (9.84 ft) | 4 | 2 Axial - One male and one female connector | PVC | Figure 4 |
| CDP12-0B-030-BB | <--> | 3m (9.84 ft) | 4 | 2 Right-angle - One male and one female connector | PVC | Figure 5 |
| 7000-40041-2150100 | <--> | 1m (3.28 ft) | 5 | 2 Axial - One male and one female connector | PVC | Figure 7 |
| 7000-40041-2150300 | <--> | 3m (9.84 ft) | 5 | 2 Axial - One male and one female connector | PVC | Figure 7 |

Patch Cables with LED

Available patch cables with LED include:

- Right-angle M12 female plug with LED indication on one end and axial male plug on the other end
- 0.3m, 0.6m, 1m, 2m, 5m, and 10m cable lengths

- PUR (polyurethane) jacket for oily and direct sunlight applications
- IP67 /IP68 / IP69K, II rated
- LED indication for 10 -36 VDC PNP sensors only

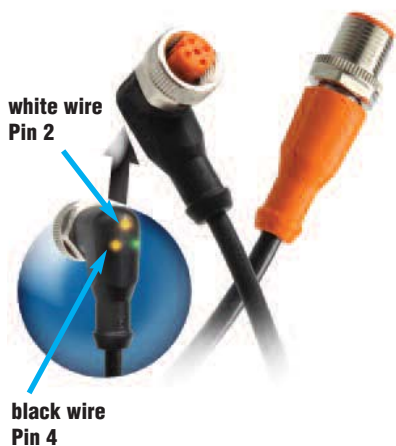

LED Models' Wiring

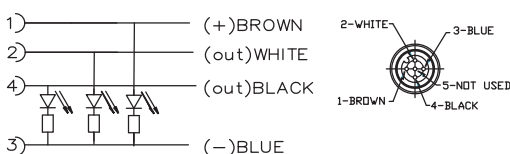

| M12 Patch Cables with LED Indicator (Euro, Micro DC-Single Key) | | | | | | | |
|---|-------|----------------|-------|--------------------------------|-----|--------|------------|
| Part Number | Price | Length | Poles | Connectors | LED | Jacket | Dimensions |
| M12 Patch Cables | | | | | | | |
| EVC322* | <--> | 0.3m (0.98 ft) | 4 | Right-angle female, axial male | Yes | PUR | Figure 6 |
| EVC323* | <--> | 0.6m (1.97 ft) | 4 | Right-angle female, axial male | Yes | PUR | Figure 6 |
| EVC324* | <--> | 1m (3.28 ft) | 4 | Right-angle female, axial male | Yes | PUR | Figure 6 |
| EVC325* | <--> | 2m (6.5 ft) | 4 | Right-angle female, axial male | Yes | PUR | Figure 6 |
| EVC326* | <--> | 5m (16.4 ft) | 4 | Right-angle female, axial male | Yes | PUR | Figure 6 |
| EVC327* | <--> | 10m (32.8 ft) | 4 | Right-angle female, axial male | Yes | PUR | Figure 6 |

***Note: LED for 10 to 36 VDC PNP devices only.
Do not use with NPN or analog output devices.
Do not use when white wire (Pin 2) is used for selection of a sensor function.
Do not use when emitter has check function.**

Sensor Cables and Connectors



Company Information

Systems Overview

Programmable Controllers

Field I/O

Software

C-more & other HMI

Drives

Soft Starters

Motors & Gearbox

Steppers/ Servos

Motor Controls

Proximity Sensors

Photo Sensors

Limit Switches

Encoders

Current Sensors

Pressure Sensors

Temperature Sensors

Pushbuttons/ Lights

Process

Relays/ Timers

Comm.

Terminal Blocks & Wiring

Power

Circuit Protection

Enclosures

Tools

Pneumatics

Safety

Appendix

Product Index

Part # Index

| Cable Specifications | | | | |
|---|-------------------------------|--|--|--|
| Specification | M8 | M12 | M12 with LED | |
| Length | 1m (3.28 ft.) / 3m (9.84 ft.) | | 0.3m (0.98 ft) / 0.6m (1.97 ft) / 1m (3.28 ft) 2m (6.5 ft) / 5m (16.4 ft) / 10m (32.8 ft) | |
| Nominal Voltage | 60 VAC/VDC | 125 VAC/VDC 250 VAC/VDC | 10 to 36 VDC | |
| Max Current | 4A | | 4A | |
| LED Current Consumption | N/A | | 10V input Brown wire LED: 1.7 mA White and/or Black LED: 0.9 mA 36V input Brown wire LED: 7.3 mA White and/or Black LED: 4.7 mA | |
| Protection Degree | IEC IP67 | | IEC IP67/IP68/IP69K | |
| Material Nut | Nickel plated brass | Zinc pressure die casting surface (Ni4-6), Nickel plated brass | Nickel plated brass | |
| Jacket Material | PolyVinyl Chloride (PVC) | | Polyurethane (PUR) | |
| Housing Material | Polyurethane (PUR) | | Connector: Orange PUR, Socket: Black PUR | |
| Contacts Material | Copper-tin(CuSn) plated brass | | Gold plated brass | |
| Conductors Cross Section (AWG) | 0.34 mm ² | | 0.34 mm ² (22 AWG) | |
| Tightening Torque | 0.5 Nm | 0.6 Nm, 0.5 Nm | Plug: 0.6 to 1.5 Nm (take into account the maximum value of the counterpart) Socket: 0.6 to 1.5 Nm | |
| Ø Outer Cable | 5mm | 5.2 mm, 5mm | 5mm | |
| Temperature Range | -25° to +70°C (-13° to 158°F) | | -25° to +90°C (-13° to 194°F) | |
| Function Display LED | N/A | | Green | |
| Switching Status LED | N/A | | 2 x Yellow | |
| Drag Chain (Roller Cable Tray) Suitability | Bending Radius | min. 10 x cable diameter | | |
| | Bending Cycles | >5 million | | |
| | Travel Speed | N/A | Max. 3.3 m/s for a horizontal travel length of 5 m and max. acceleration of 5 m/s ² | |
| | Torsional Strain | N/A | ±180°/m | |
| Agency Approvals | RoHS | | UL File E191684, RoHS | |

| UL Reference | |
|---|--|
| Part Number | Cable Assemblies Series M12, UL Catalog Number |
| EVC322 | VDOAH043MSS00.3H04STGH040MSS |
| EVC323 | VDOAH043MSS00.6H04STGH040MSS |
| EVC324 | VDOAH043MSS0001H04STGH040MSS |
| EVC325 | VDOAH043MSS0002H04STGH040MSS |
| EVC326 | VDOAH043MSS0005H04STGH040MSS |
| EVC327 | VDOAH043MSS0010H04STGH040MSS |
| Note: Shown in UL file under Cable Assemblies using catalog number | |

Sensor Cables and Connectors

Dimensions mm [inches]

Figure 1

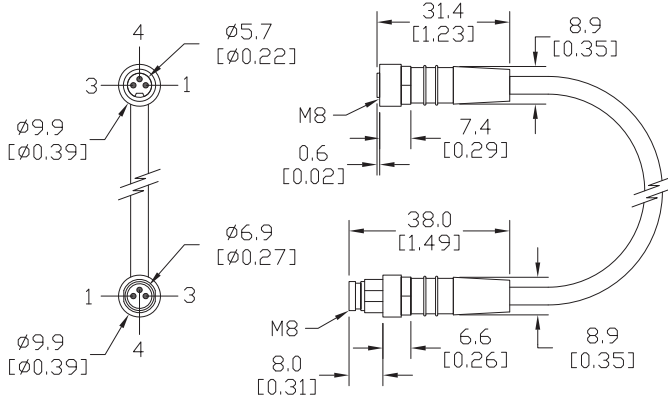

Figure 2

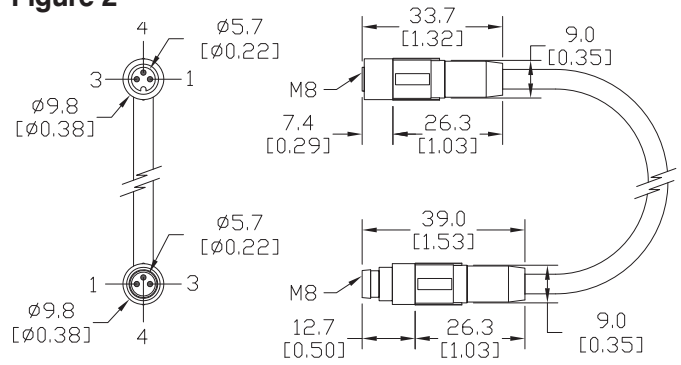

Figure 3

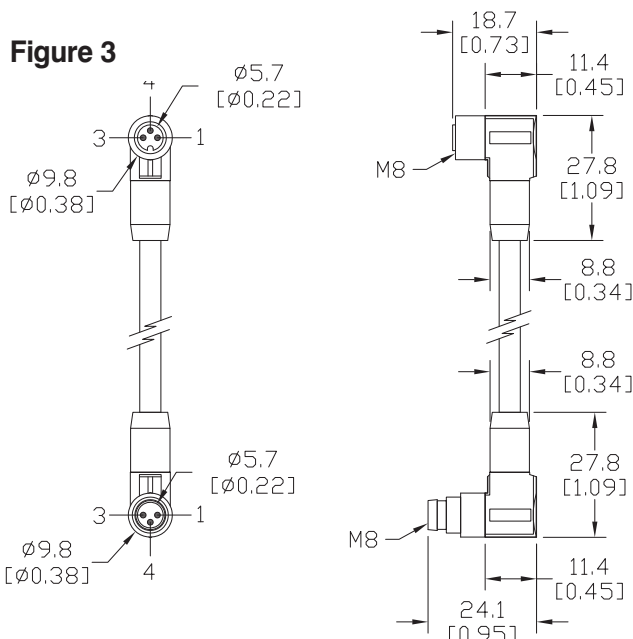

Figure 4

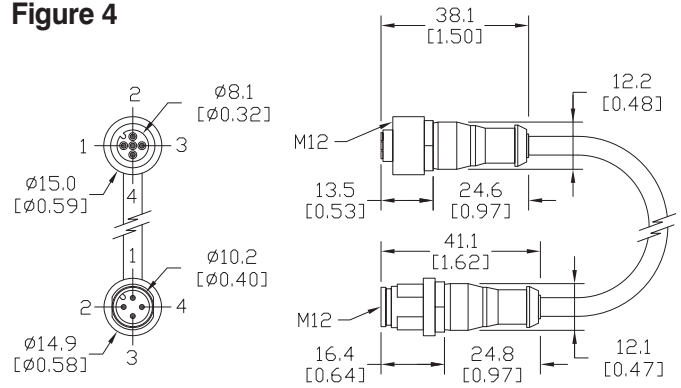

Figure 5

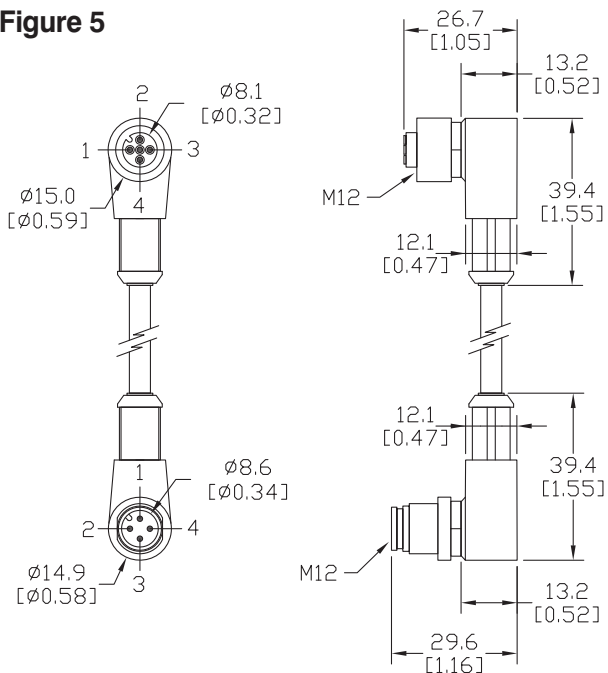

Figure 6

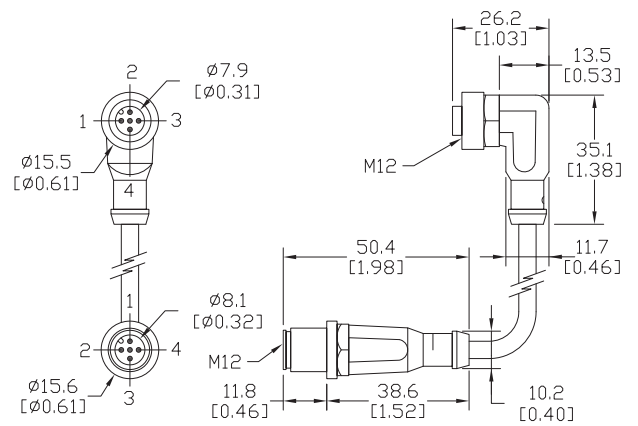
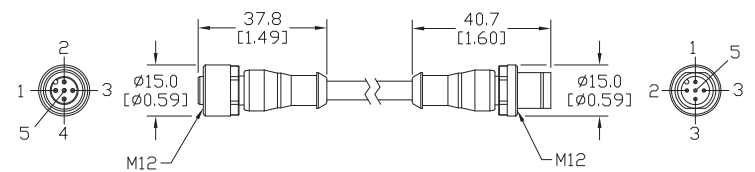

Figure 7



Sensor Cables and Connectors

Cables with quick-disconnect plugs for DFT/DFP Sensor Models

Do not use extension cables with the cables listed below. The physical pin configurations do not match.

Available cables include:

- Industry standard M8 screw-lock connectors
- Axial and right-angle connector models
- 2m, 5m and 10m cable lengths
- PVC (polyvinyl chloride) jacket for typical industrial applications
- IP68 rated



| M8 Cables with Quick-Disconnect | | | | | | |
|---------------------------------|-------|----------------|-------|--------------------|--------|------------|
| Part Number | Price | Length | Poles | Connectors | Jacket | Dimensions |
| M8 Quick-Disconnects | | | | | | |
| CD08-0G-020-A1 | <---> | 2m (6.56 ft.) | 4 | Axial female | PVC | Figure 1 |
| CD08-0W-020-C1 | <---> | 2m (6.56 ft.) | 4 | Right-angle female | PVC | Figure 2 |
| CD08-0G-050-A1 | <---> | 5m (16.4 ft.) | 4 | Axial female | PVC | Figure 1 |
| CD08-0W-050-C1 | <---> | 5m (16.4 ft.) | 4 | Right-angle female | PVC | Figure 2 |
| CD08-0G-100-A1 | <---> | 10m (32.8 ft.) | 4 | Axial female | PVC | Figure 1 |
| CD08-0W-100-C1 | <---> | 10m (32.8 ft.) | 4 | Right-angle female | PVC | Figure 2 |

Use these cables if the sensor pin configuration looks like the connector pin-out below.

M8 Connector

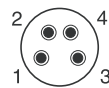

| Cable Specifications | M8 |
|-----------------------|--|
| Length | 2m (6.56 ft.) 5m (16.4 ft.) 10m (32.8 ft.) |
| Nominal Voltage | 30VAC/30VDC |
| Nominal Current | 4A |
| Protection Degree | IEC IP67 |
| Contact Body Material | ABS |
| Housing Material | PUR |
| Contacts Material | CuSn |
| Conductors Section | 0.25 mm ² |
| Ø Outer Cable | 4.5 mm |
| Temperature Range | -5° to +70°C (23° to 158°F) |

Dimensions (mm)

Figure 1

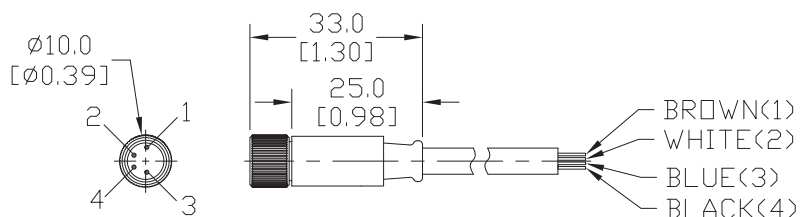
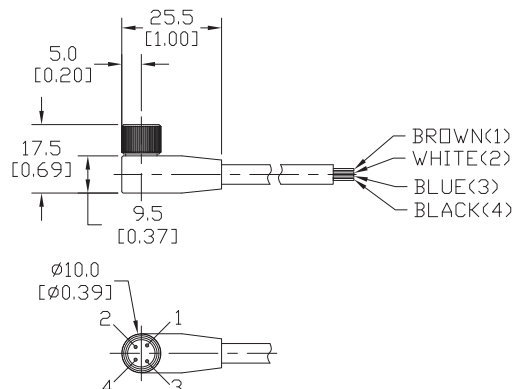

Figure 2



Sensors Accessories – IP69K-rated Cables

Cables with quick-disconnect plugs

- Industry standard axial and right-angle M12 or 1/2" micro connectors with open leads
- 5m and 10m cable lengths

- PVC (polyvinyl chloride) jacket for food and beverage industrial applications
- IP69K rated for food and beverage industrial applications
- 316L stainless steel coupling nut
- EPDM o-ring

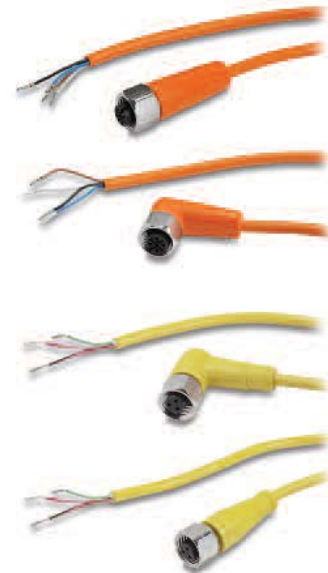

| M12 Quick-Disconnect Cables (Euro, Micro DC-Single Key) | | | | | | | |
|---|-------|---------------|-------|--------------------|-----|------------|------------|
| Part Number | Price | Length | Poles | Connector | LED | Jacket | Dimensions |
| M12 Quick-Disconnects | | | | | | | |
| EVT221 | <---> | 5m (16.4 ft) | 4 | Axial female | No | Orange PVC | Figure 4 |
| EVT222 | <---> | 5m (16.4 ft) | 4 | Right-angle female | No | Orange PVC | Figure 1 |
| EVT223 | <---> | 10m (32.8 ft) | 4 | Axial female | No | Orange PVC | Figure 4 |
| EVT224 | <---> | 10m (32.8 ft) | 4 | Right-angle female | No | Orange PVC | Figure 1 |
| Micro AC Volt 1/2 Inch - 20UNF Cables | | | | | | | |
| 1/2" Quick-Disconnects | | | | | | | |
| E18446 | <---> | 5m (16.4 ft) | 3 | Axial female | No | Yellow PVC | Figure 6 |
| E18447 | <---> | 5m (16.4 ft) | 3 | Right-angle female | No | Yellow PVC | Figure 5 |
| E18448 | <---> | 10m (32.8 ft) | 3 | Axial female | No | Yellow PVC | Figure 6 |
| E18449 | <---> | 10m (32.8 ft) | 3 | Right-angle female | No | Yellow PVC | Figure 5 |

Patch cables with quick-disconnect plugs on each end

Available patch cables include:

- Industry standard M12 screw-lock connectors
- One male and one female connector

- Axial and right-angle connector models
- 0.3m, 0.6m, 1m, 2m and 5m cable lengths
- PVC (polyvinyl chloride) jacket for food and beverage industrial applications
- IP69K rating, suitable for food and beverage industrial applications
- 316L stainless steel coupling nut
- EPDM o-ring



| M12 Patch Cables with Quick-Disconnect on Each End (Euro, Micro DC-Single Key) | | | | | | |
|--|-------|----------------|-------|--|------------|------------|
| Part Number | Price | Length | Poles | Connectors | Jacket | Dimensions |
| M12 Quick-Disconnect Patch Cables | | | | | | |
| EVT225 | <---> | 0.3m (0.98 ft) | 4 | Axial female plug to axial male plug | Orange PVC | Figure 3 |
| EVT226 | <---> | 0.3m (0.98 ft) | 4 | Right angle female plug to axial male plug | Orange PVC | Figure 2 |
| EVT227 | <---> | 0.6m (1.97 ft) | 4 | Axial female plug to axial male plug | Orange PVC | Figure 3 |
| EVT228 | <---> | 0.6m (1.97 ft) | 4 | Right angle female plug to axial male plug | Orange PVC | Figure 2 |
| EVT229 | <---> | 1m (3.3 ft) | 4 | Axial female plug to axial male plug | Orange PVC | Figure 3 |
| EVT230 | <---> | 1m (3.3 ft) | 4 | Right angle female plug to axial male plug | Orange PVC | Figure 2 |
| EVT231 | <---> | 2m (6.6 ft) | 4 | Axial female plug to axial male plug | Orange PVC | Figure 3 |
| EVT232 | <---> | 2m (6.6 ft) | 4 | Right angle female plug to axial male plug | Orange PVC | Figure 2 |
| EVT233 | <---> | 5m (16.4 ft) | 4 | Axial female plug to axial male plug | Orange PVC | Figure 3 |
| EVT234 | <---> | 5m (16.4 ft) | 4 | Right angle female plug to axial male plug | Orange PVC | Figure 2 |

Sensors Accessories – IP69K-rated Cables

| Cable Specifications | | |
|--------------------------------|---|------------------------------|
| Specification | M12 | 1/2" |
| Length | 0.3m (0.98 ft), 0.6m (1.97 ft), 1m (3.3 ft), 2m (6.6 ft), 5m (16.4 ft), 10m (32.8 ft) | 5m (16.4 ft), 10m (32.8 ft) |
| Nominal Voltage | 250 VAC/300 VDC | 300 VAC/VDC |
| Max Current | 4A | 4A |
| Protection Degree | IEC IP67 / IP68 / IP69K | IEC IP67 / IP68 / IP69K |
| Material Nut | 316L Stainless steel | 316L Stainless steel |
| Jacket Material | PolyVinyl Chloride (PVC) | PolyVinyl Chloride (PVC) |
| Housing Material | PolyVinyl Chloride (PVC) | PolyVinyl Chloride (PVC) |
| Contacts Material | Gold plated | Gold plated |
| Tightening Torque | 0.6 to 1.5 Nm | |
| Conductors Cross Section (AWG) | 22 AWG | 22 AWG |
| Ø Outer Cable | 4.9 mm | 4.5 mm |
| Temperature Range | -25° to 100°C (-13° to 212°F) | -10° to 100°C (14° to 212°F) |
| Environmental | Halogen free, Silicone free | Halogen free, Silicone free |
| Bending Radius | min. 10 x cable diameter | |
| Agency Approvals | UL E191684 | UL E177636 |

Wiring - M12 DC

EVT221, EVT222, EVT223, EVT224

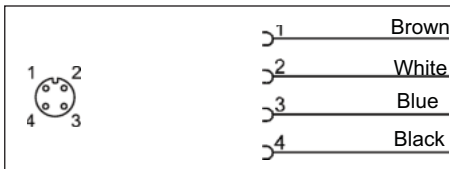

EVT225, EVT226, EVT227, EVT228, EVT229, EVT230, EVT231, EVT232, EVT233, EVT234

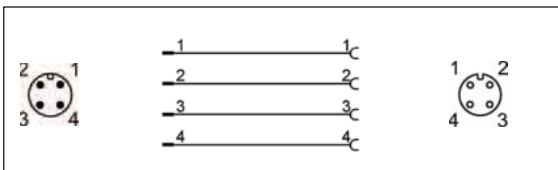

Wiring - 1/2" Micro AC

E18446, E18447, E18448, E18449

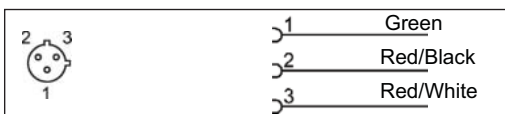

| UL Reference | |
|--------------|------------------------------|
| Part Number | UL Catalog Number |
| EVT221 | ADOGH040VAS0005E04 |
| EVT222 | ADOAH040VAS0005E04 |
| EVT223 | ADOGH040VAS0010E04 |
| EVT224 | ADOAH040VAS0010E04 |
| EVT225 | VDOGH040VAS00.3E04STGH040VAS |
| EVT226 | VDOAH040VAS00.3E04STGH040VAS |
| EVT227 | VDOGH040VAS00.6E04STGH040VAS |
| EVT228 | VDOAH040VAS00.6E04STGH040VAS |
| EVT229 | VDOGH040VAS0001E04STGH040VAS |
| EVT230 | VDOAH040VAS0001E04STGH040VAS |
| EVT231 | VDOGH040VAS0002E04STGH040VAS |
| EVT232 | VDOAH040VAS0002E04STGH040VAS |
| EVT233 | VDOGH040VAS0005E04STGH040VAS |
| EVT234 | VDOAH040VAS0005E04STGH040VAS |

Sensors Accessories – IP69K-rated Cables

Dimensions

mm [inches]

Figure 1

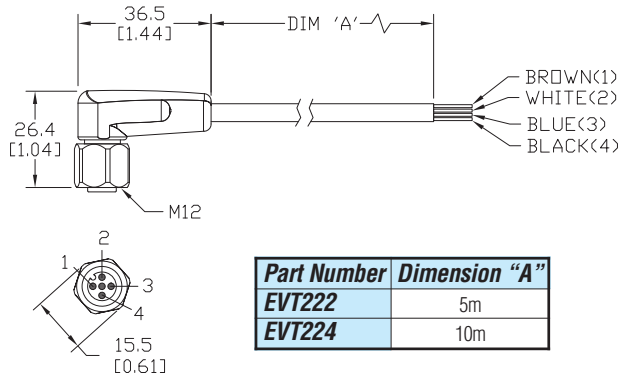

Figure 2

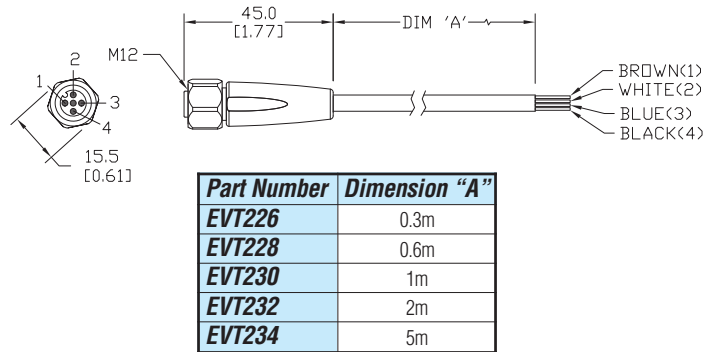

Figure 3

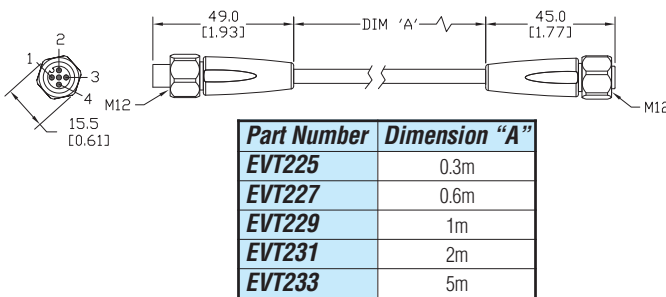

Figure 4

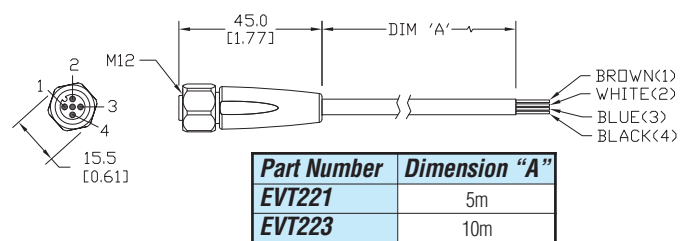

Figure 5

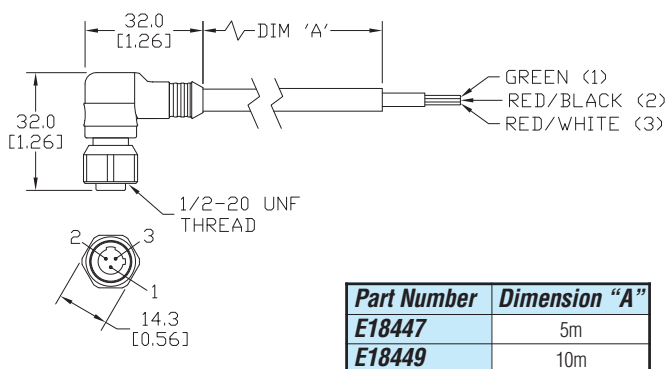
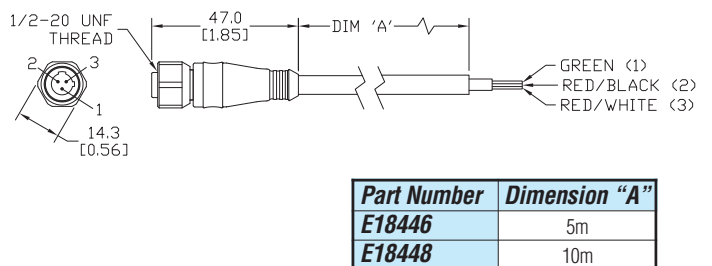

Figure 6



Field Wireable Connectors



Features and Selection Guides

- M8 and M12 connectors
- IDC (insulation displacement connection) allows quick termination without stripping conductors
- IP67 rated once properly assembled
- Various cable gauges and diameters accepted



Field Wireable M8 Insulation Displacement (IDC) Connectors Selection Table

| Part Number | Price | Voltage | Poles | Connector Type | Conductor Wire | Housing Material | Outside Cable Diameter |
|--------------------|-------|------------|-------|----------------|--|--|-------------------------------------|
| 7000-08321-0000000 | <---> | 32 VAC/VDC | 3 | Axial male | 20 to 24 AWG (0.5 to 0.25 mm ²) | Thermoplastic polyester elastomer (TPE- E) | 4 to 5.1 mm (0.157 to 0.20 in) |
| 7000-08341-0000000 | <---> | 32 VAC/VDC | 4 | | | | |
| 7000-08361-0000000 | <---> | 32 VAC/VDC | 3 | Axial female | 20 to 24 AWG (0.5 to 0.25 mm ²) | Thermoplastic polyester elastomer (TPE- E) | 4 to 5.1 mm (0.157 to 0.20 in) |
| 7000-08381-0000000 | <---> | 32 VAC/VDC | 4 | | | | |
| 7000-08331-0000000 | <---> | 32 VAC/VDC | 3 | Axial male | 22 to 26 (0.34 to 0.14 mm ²) | Polyamide (PA) | 2.5 to 5.1 mm (0.098 to 0.20 in) |
| 7000-08351-0000000 | <---> | 32 VAC/VDC | 4 | | | | |
| 7000-08371-0000000 | <---> | 32 VAC/VDC | 3 | Axial female | 22 to 26 (0.34 to 0.14 mm ²) | Polyamide (PA) | 2.5 to 5.1 mm (0.098 to 0.20 in) |
| 7000-08391-0000000 | <---> | 32 VAC/VDC | 4 | | | | |

Field Wireable M12 Insulation Displacement (IDC) Connectors Selection Table

| Part Number | Price | Voltage | Poles | Connection Type | Conductor Wire | Housing Material | Outside Cable Diameter |
|--------------------|-------|------------|-------|--------------------|---|--|-------------------------------------|
| 7000-12481-0000000 | <---> | 32 VAC/VDC | 4 | Axial male | 20 to 24 AWG (0.5 to 0.25 mm ²) | Thermoplastic polyester elastomer (TPE- E) | 4 to 5.1 mm (0.157 to 0.20 in) |
| 7000-12601-0000000 | <---> | 32 VAC/VDC | | Axial female | | | |
| 7000-12491-0000000 | <---> | 32 VAC/VDC | | Axial male | 22 to 26 AWG (0.34 to 0.14 mm ²) | Polyamide (PA) | 2.9 to 5.1 mm (0.114 to 0.20 in) |
| 7000-12611-0000000 | <---> | 32 VAC/VDC | | Axial female | | | |
| 7000-12561-0000000 | <---> | 32 VAC/VDC | | Right-angle male | 20 to 24 AWG (0.5 to 0.25 mm ²) | Thermoplastic polyester elastomer (TPE- E) | 4 to 5.1 mm (0.157 to 0.20 in) |
| 7000-12681-0000000 | <---> | 32 VAC/VDC | | Right-angle female | | | |

Field Wireable M12 Screw Connectors Selection Table

| Part Number | Price | Voltage | Poles | Connection Type | Conductor Wire | Housing Material | Outside Cable Diameter |
|--------------------|-------|-------------|-------|--------------------|-------------------------------------|------------------------------------|----------------------------------|
| 7000-12701-0000000 | <---> | 250 VAC/VDC | 4 | Axial male | 18 AWG (0.75 mm ²) max. | Polyamide (PA) | 4 to 6 mm (0.157 to 0.236 in) |
| 7000-12721-0000000 | <---> | 125 VAC/VDC | 5 | Axial male | | | |
| 7000-12901-0000000 | <---> | 250 VAC/VDC | 4 | Axial female | | | |
| 7000-12921-0000000 | <---> | 125 VAC/VDC | 5 | Axial female | | | |
| 7000-12741-0000000 | <---> | 250 VAC/VDC | 4 | Axial male | | | |
| 7000-12761-0000000 | <---> | 125 VAC/VDC | 5 | Axial male | | | |
| 7000-12941-0000000 | <---> | 250 VAC/VDC | 4 | Axial female | | 20 AWG (0.5 mm ²) max. | PUR |
| 7000-12961-0000000 | <---> | 125 VAC/VDC | 5 | Axial female | | | |
| 7000-12821-0000000 | <---> | 250 VAC/VDC | 4 | Right-angle male | | | |
| 7000-12981-0000000 | <---> | 250 VAC/VDC | 4 | Right-angle female | | | |
| 7000-17301-0000000 | <---> | 60 VAC/VDC | 8 | Axial male | | | |
| 7000-17311-0000000 | <---> | 60 VAC/VDC | 8 | Right-angle male | | | |
| 7000-17321-0000000 | <---> | 60 VAC/VDC | 8 | Axial female | PUR | 6 to 8 mm (0.236 to 0.315 in) | |
| 7000-17331-0000000 | <---> | 60 VAC/VDC | 8 | Right-angle female | | | |
| Shielded | | | | | | | |
| 7000-13321-0000000 | <---> | 125 VAC/VDC | 5 | Axial male | 18 AWG (0.75 mm ²) max. | PUR | 6 to 8 mm (0.236 to 0.315 in) |
| 7000-13361-0000000 | <---> | 125 VAC/VDC | 5 | Right-angle male | | | |
| 7000-17341-0000000 | <---> | 60 VAC/VDC | 8 | Axial male | 20 AWG (0.5 mm ²) max. | | |

Field Wireable Connectors

| Field Wireable Connectors Specifications | | | | | | |
|--|---|---------------------------------------|------------------------------------|-------------------|--|---|
| Connection | Insulation Displacement Connection | | | | Screw Connection | |
| | M8 | | M12 | | M12 | |
| Outside Cable Diameter (mm) | 4 to 5.1 | 2.5 to 5.1 | 2.9 to 5.1 | 4 to 5.1 | 4.0 to 6.0 | 6.0 to 8.0 |
| Nominal Voltage | 32 VAC/VDC | | | | 4-pin: 250 volts 5-pin: 125 volts | 4-pin: 250 volts 5-pin: 125 volts 8-pin: 60 volts |
| Current (max) | 4-pole: 3A; 3-pole: 4A | | 4A | | 4A | 4-pin and 5-pin: 4A 8-pin: 2A |
| Temperature | -25° to 85°C (13° to 185°F) | | | | | |
| Environmental Protection | IP67 | | | | | |
| Isolation Materials | (Recommended conductor insulation) PVC/PP/TPE PolyVinyl Chloride/Polypropylene/Thermoplastic Elastomer | | | | N/A | |
| Wire Diameter | 1.2 to 1.6 mm [0.047 to 0.063 in.] | 1.0 to 1.6 mm [0.039 to 0.063 in.] | 1.2 to 1.6 mm [0.047 to 0.063 in.] | | N/A | |
| Isolation Resistance | Category III per IEC 60664-1 | | | | | |
| Screw | N/A | | | | M2.5x0.45 mm. torque to 40 Nm (3.54 in.lb) | |
| Weight | 0.03 oz (13.61 g) | 0.04 oz (18.14 g) | 0.05 oz (22.68 g) | 0.06 oz (27.21 g) | 0.05 oz (22.68 g) | 0.06 oz (27.21 g) |
| Agency Approvals | UL Recognized. File E224242 | | | | | |

Dimensions mm [inches]

| LEGEND | |
|--------|---------------------------|
| ■ | MALE PIN ON CONNECTOR |
| ○ | FEMALE PIN ON CONNECTOR |
| (| FIELD CONNECTION TERMINAL |

7000-08321-000000

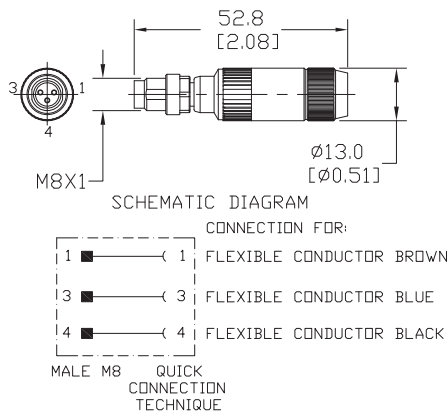

7000-08341-000000

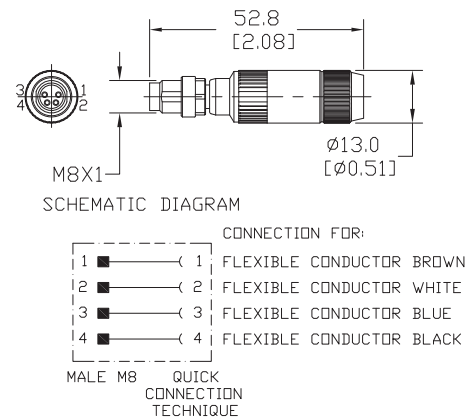

7000-08361-000000

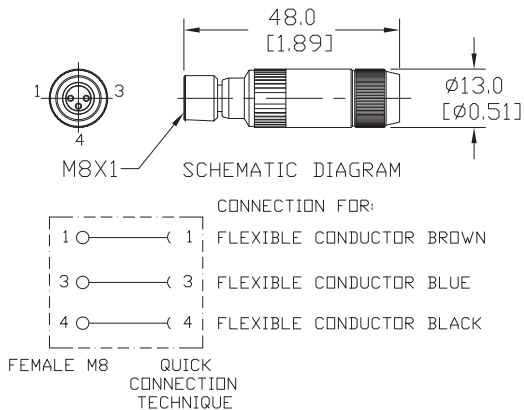

7000-08381-000000

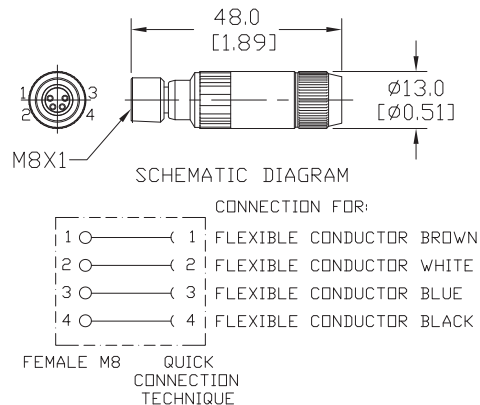

Field Wireable Connectors

| LEGEND | |
|--------|---------------------------|
| ■ | MALE PIN ON CONNECTOR |
| ○ | FEMALE PIN ON CONNECTOR |
| (| FIELD CONNECTION TERMINAL |

Dimensions mm [inches]

7000-08331-000000

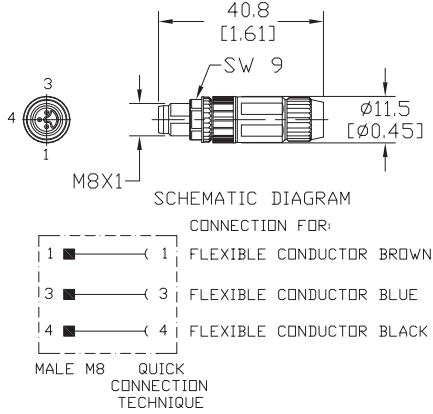

7000-08351-000000

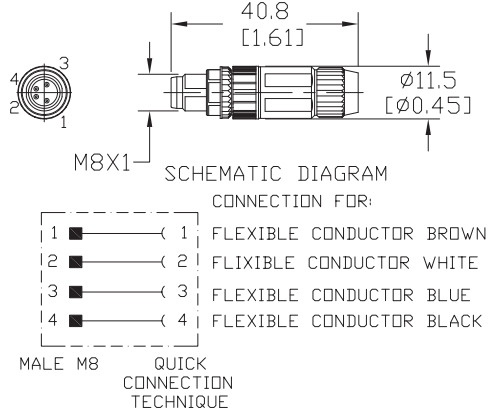

7000-08371-000000

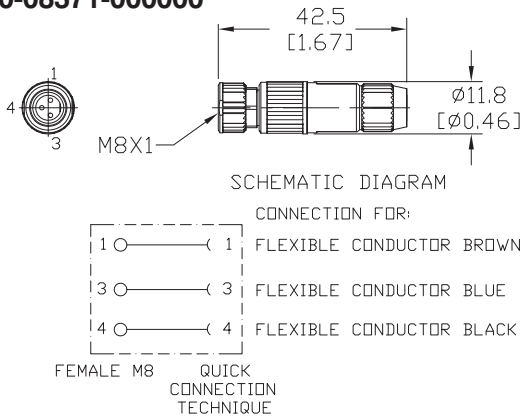

7000-08391-000000

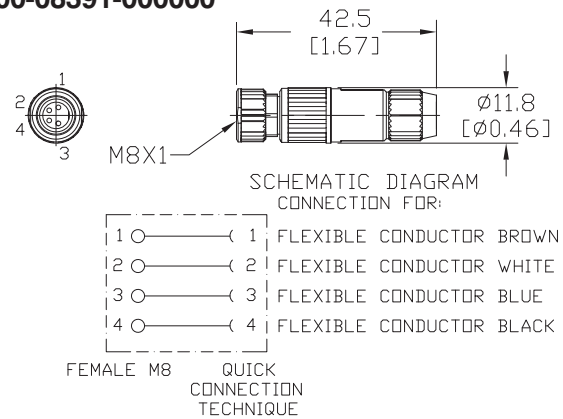

7000-12481-000000

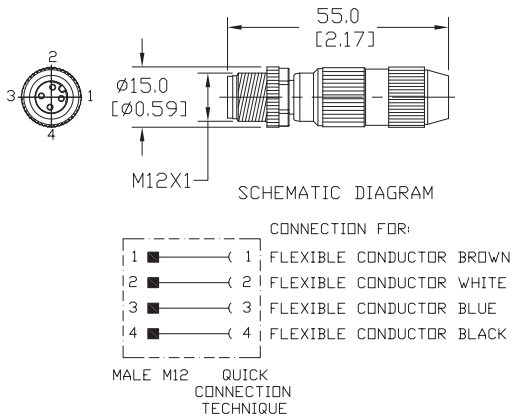

7000-12601-000000

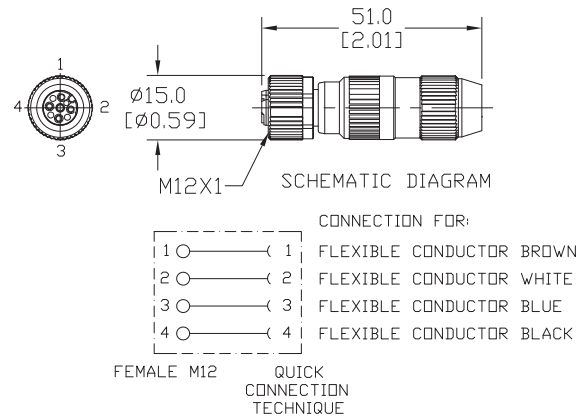

Field Wireable Connectors

| LEGEND | |
|--------|---------------------------|
| ■ | MALE PIN ON CONNECTOR |
| ○ | FEMALE PIN ON CONNECTOR |
| (| FIELD CONNECTION TERMINAL |

Dimensions mm [inches]

7000-12491-000000

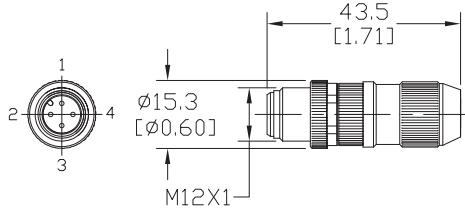

SCHEMATIC DIAGRAM
CONNECTION FOR:

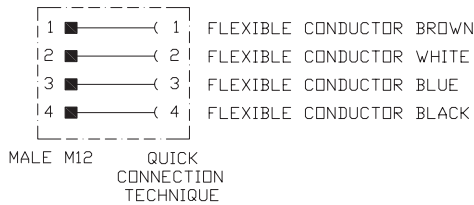

7000-12611-000000

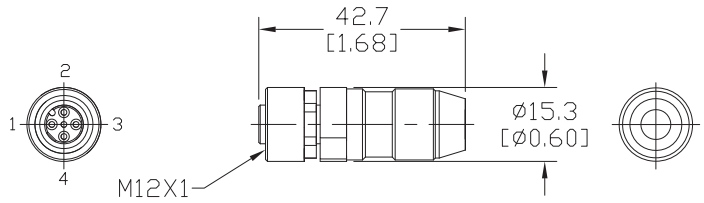

SCHEMATIC DIAGRAM
CONNECTION FOR:

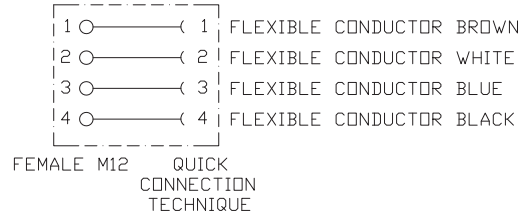

7000-12561-000000

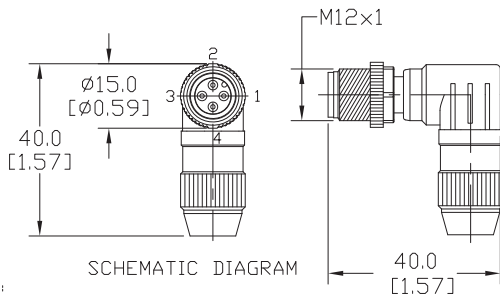

SCHEMATIC DIAGRAM

CONNECTION FOR:

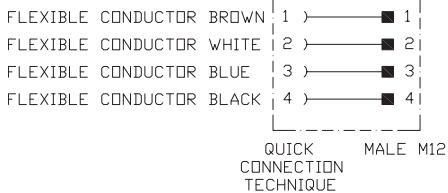

7000-12681-000000

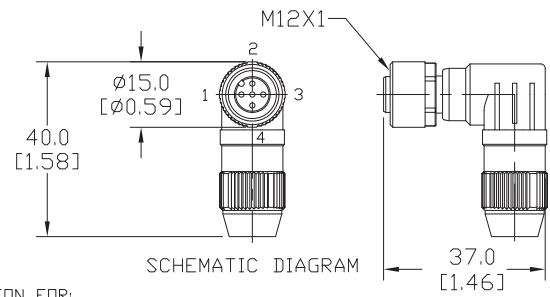

SCHEMATIC DIAGRAM

CONNECTION FOR:

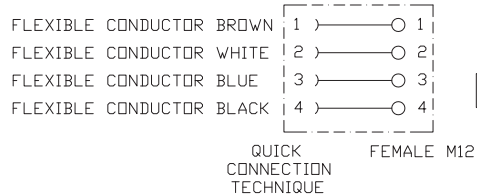

7000-12701-000000

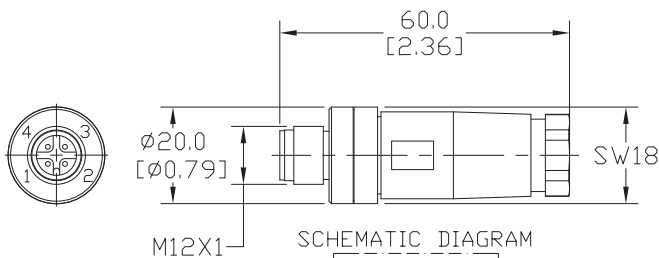

SCHEMATIC DIAGRAM

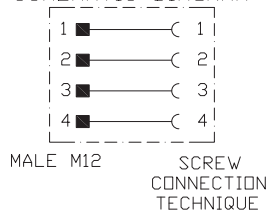

7000-12721-000000

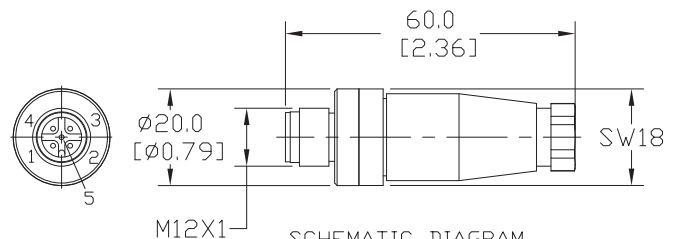

SCHEMATIC DIAGRAM

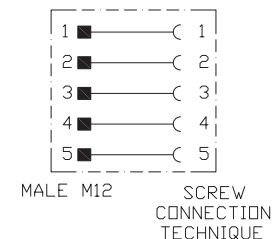

Field Wireable Connectors

| LEGEND | |
|--------|---------------------------|
| ■ | MALE PIN ON CONNECTOR |
| ○ | FEMALE PIN ON CONNECTOR |
| (| FIELD CONNECTION TERMINAL |

Dimensions mm [inches]

7000-12901-000000

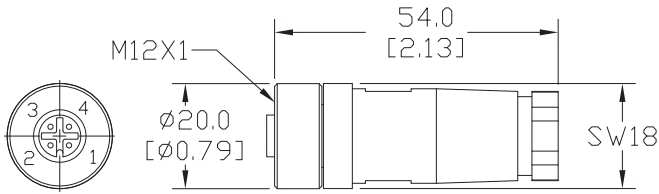

SCHEMATIC DIAGRAM

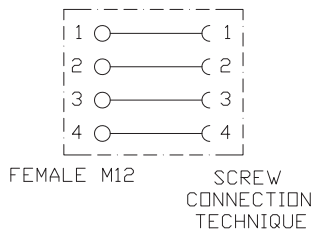

7000-12921-000000

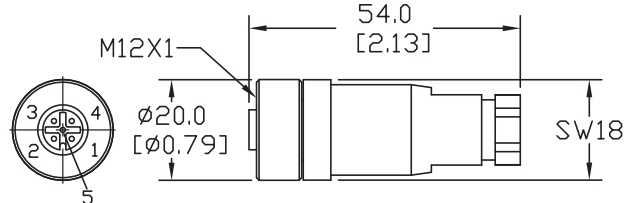

SCHEMATIC DIAGRAM

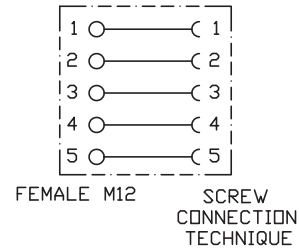

7000-12741-000000

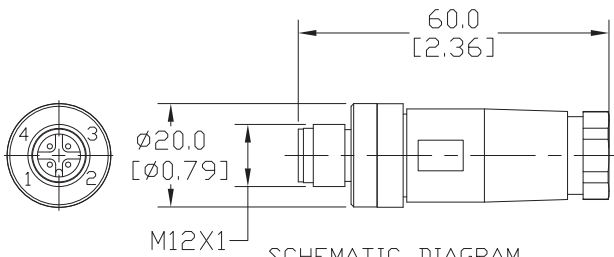

SCHEMATIC DIAGRAM

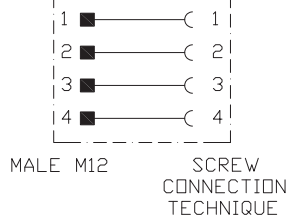

7000-12761-000000

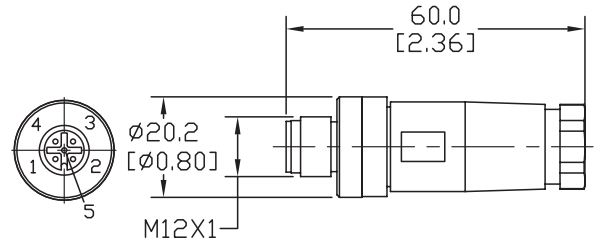

SCHEMATIC DIAGRAM

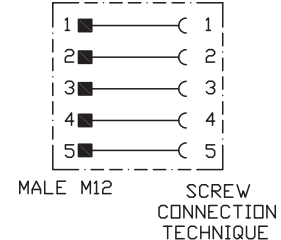

7000-12941-000000

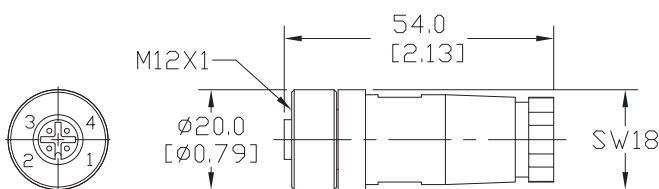

SCHEMATIC DIAGRAM

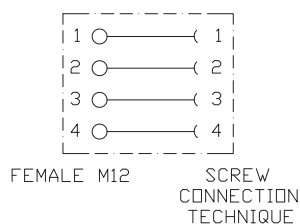

7000-12961-000000

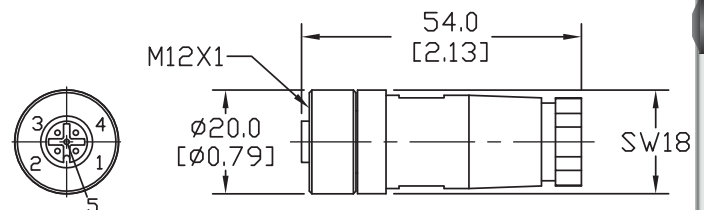

SCHEMATIC DIAGRAM

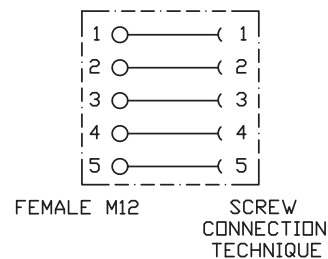

Field Wireable Connectors

| LEGEND | |
|--------|---------------------------|
| ■ | MALE PIN ON CONNECTOR |
| ○ | FEMALE PIN ON CONNECTOR |
| (| FIELD CONNECTION TERMINAL |

Dimensions mm [inches]

7000-12821-000000

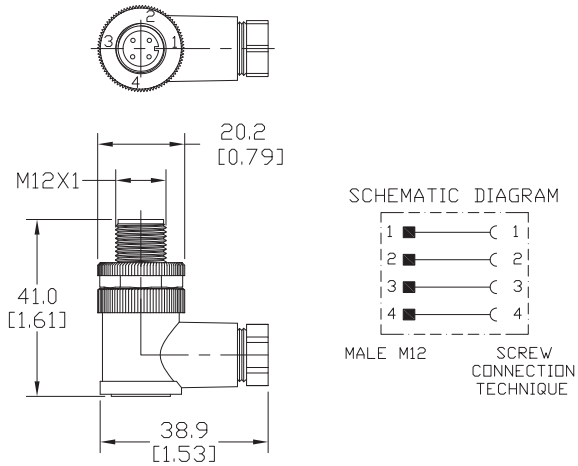

7000-12981-000000

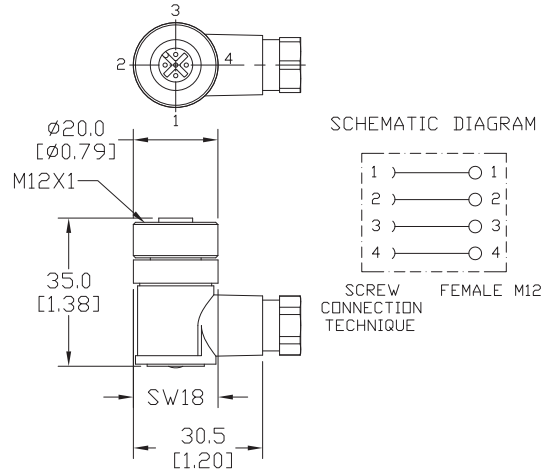

7000-13321-000000

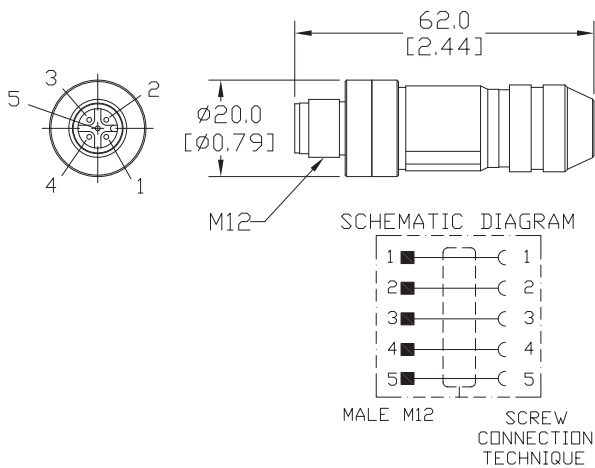

7000-13361-000000

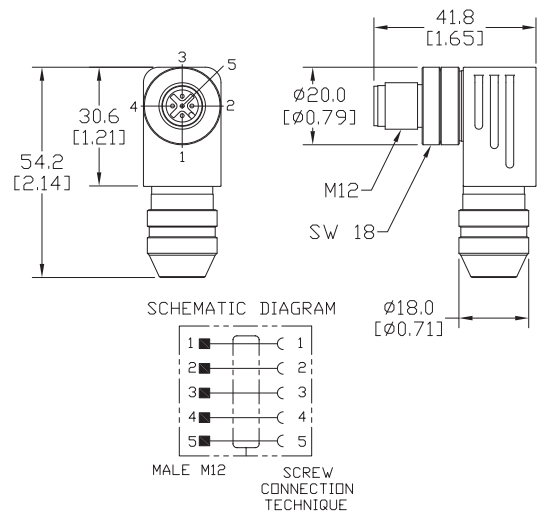

7000-17301-000000

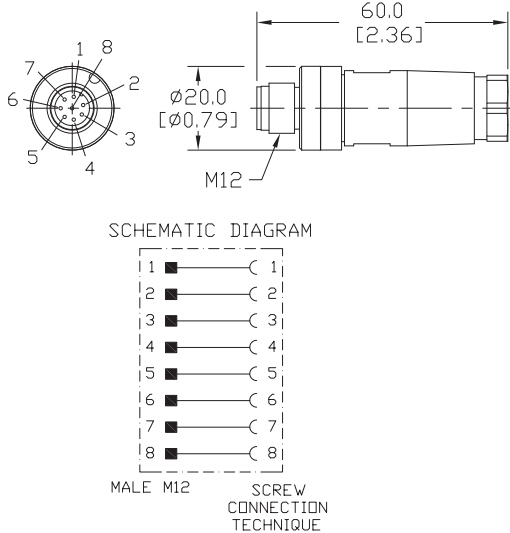

7000-17311-000000

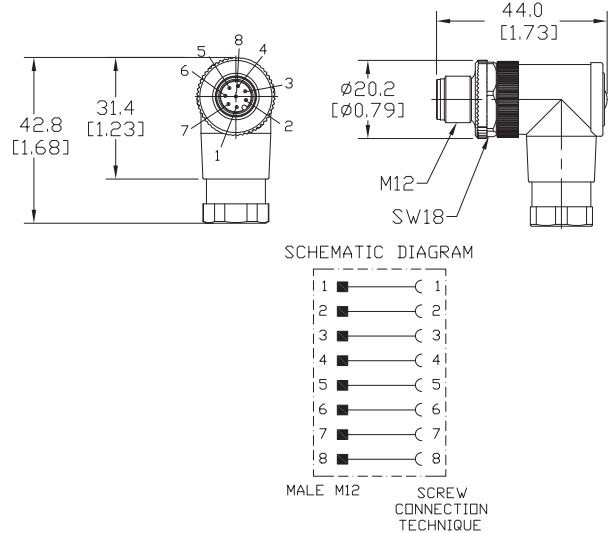

Field Wireable Connectors

| LEGEND | |
|--------|---------------------------|
| ■ | MALE PIN ON CONNECTOR |
| ○ | FEMALE PIN ON CONNECTOR |
| (| FIELD CONNECTION TERMINAL |

Dimensions mm [inches]

7000-17321-000000

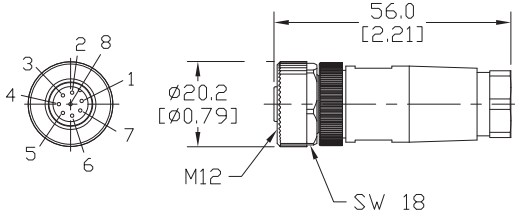

SCHEMATIC DIAGRAM

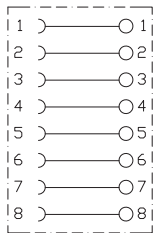

SCREW CONNECTION TECHNIQUE FEMALE M12

7000-17331-000000

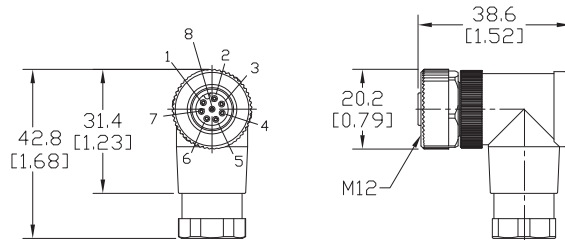

SCHEMATIC DIAGRAM

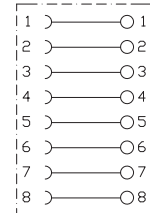

SCREW CONNECTION TECHNIQUE FEMALE M12

7000-17341-000000

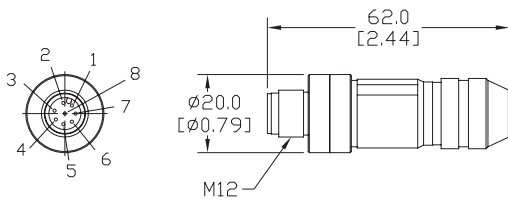

SCHEMATIC DIAGRAM

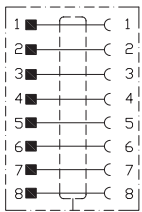

SCREW CONNECTION TECHNIQUE MALE M12

T-Couplers



Features and Selection Guide

- Molded T-couplers allow for various wire splitting
- Standard M12 or M8 connections available
- Uses include splitting power to multiple devices or bringing multiple device signals into a wiring block
- Made of molded polyurethane



| T-Couplers Selection Table | | | | | |
|----------------------------|-------|------------------|-------|-------------------|-------|
| Part Number | Price | Trunk Connection | Poles | Branch Connection | Poles |
| 7000-41121-0000000 | <---> | 1 M12 male | 5 | 2 M12 female | 4 |
| 7000-41141-0000000 | <---> | 1 M12 male | 5 | 2 M12 female | 5 |
| 7000-41181-0000000 | <---> | 1 M12 male | 5 | 2 M12 female | 5 |
| 7000-41201-0000000 | <---> | 1 M12 male | 4 | 2 M8 female | 3 |

| Field Wireable Connectors T-Couplers Specifications | | | | |
|---|------------------------------------|-------------------|-------------------|-------------------|
| Outside Cable Diameter | 41121 | 41141 | 41181 | 41201 |
| Nominal Voltage | 125 VAC/VDC | 60 VAC/VDC | 125 VAC/VDC | 60 VAC/VDC |
| Current (max) | 4A | | | |
| Temperature | -25° to 85°C (13° to 185°F) | | | |
| Environmental Protection | IP67 | | | |
| Material | Housing: Polyurethane (PUR) | | | |
| Screw | Zinc diecast; torque: M12x1 0.6 Nm | | | |
| Connection | Pluggable, screw-locking | | | |
| Weight | 0.06 oz (27.21 g) | 0.06 oz (27.21 g) | 0.06 oz (27.21 g) | 0.05 oz (22.68 g) |
| Agency Approvals | cULus Listed E325311 | | | |

Dimensions mm [inches]

7000-41121-0000000

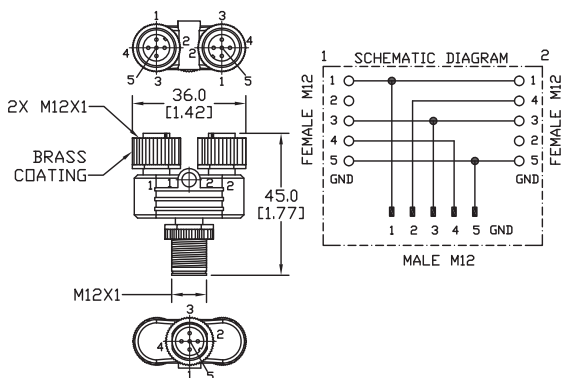

7000-41141-0000000

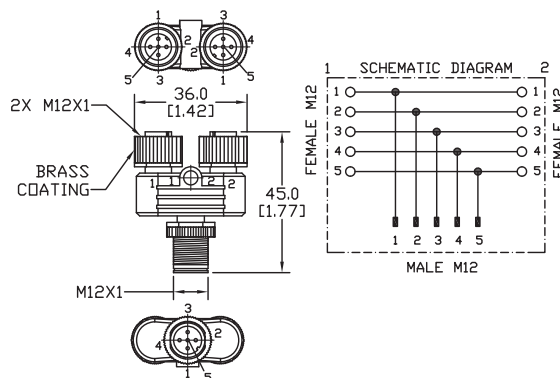

7000-41181-0000000

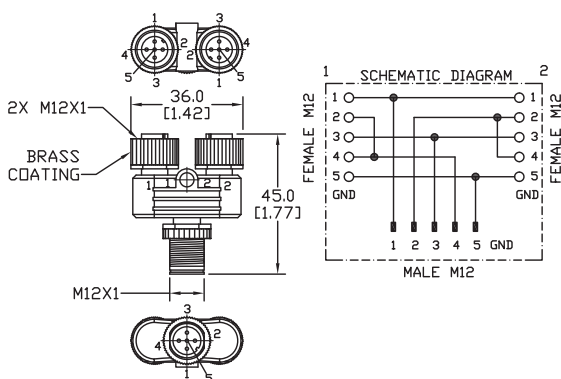

7000-41201-0000000

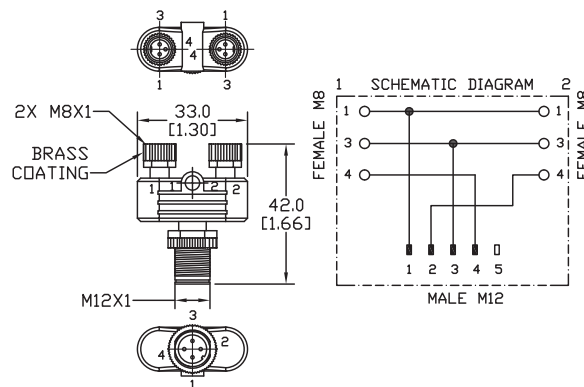

Bulkhead Connectors

Features and Selection Guide

7000-42111-0000000

7231-13501-9710050

7231-13541-9710050

- Male or Female M12 to open leads connectors
- Male M12 to female M12 connectors
- Metal housings
- IP67 rated

Bulkhead Connectors Selection Table

| Part Number | Price | Cable Length | Poles | Connector | Jacket | Dimensions |
|---------------------------|-------|----------------|-------|------------------------|--------|------------|
| 7000-42111-0000000 | <---> | N/A | 5 | M12 male to M12 female | N/A | Figure 1 |
| 7000-48111-0000000 | <---> | N/A | 8 | M12 male to M12 female | N/A | Figure 2 |
| 7231-13501-9710050 | <---> | 0.5m (1.64 ft) | 4 | M12 male to leads | PVC | Figure 3 |
| 7231-13501-9710100 | <---> | 1m (3.28 ft) | 4 | M12 male to leads | PVC | Figure 3 |
| 7231-13521-9720050 | <---> | 0.5m (1.64 ft) | 5 | M12 male to leads | PVC | Figure 4 |
| 7231-13521-9720100 | <---> | 1m (3.28 ft) | 5 | M12 male to leads | PVC | Figure 4 |
| 7231-13541-9710050 | <---> | 0.5m (1.64 ft) | 4 | M12 female to leads | PVC | Figure 5 |
| 7231-13541-9710100 | <---> | 1m (3.28 ft) | 4 | M12 female to leads | PVC | Figure 5 |
| 7231-13561-9720050 | <---> | 0.5m (1.64 ft) | 5 | M12 female to leads | PVC | Figure 6 |
| 7231-13561-9720100 | <---> | 1m (3.28 ft) | 5 | M12 female to leads | PVC | Figure 6 |
| 7231-17161-9730050 | <---> | 0.5m (1.64 ft) | 8 | M12 male to leads | PVC | Figure 7 |
| 7231-17161-9730100 | <---> | 1m (3.28 ft) | 8 | M12 male to leads | PVC | Figure 7 |
| 7231-17181-9730050 | <---> | 0.5m (1.64 ft) | 8 | M12 female to leads | PVC | Figure 8 |
| 7231-17181-9730100 | <---> | 1m (3.28 ft) | 8 | M12 female to leads | PVC | Figure 8 |

Connector Specifications

| Specification | M12 to Leads | M12 Male to M12 Female |
|---------------------------------------|--|--------------------------------------|
| Cable Length | 0.5m (1.64 ft) / 1m (3.28 ft) | N/A |
| Nominal Voltage | 8 pole: 30 VAC/VDC 5 pole: 125 VAC/VDC 4 pole: 250 VAC/VDC | 24 VAC/VDC |
| Max Current | 8 pole: 2A 4/5 pole: 4A | 8 pole: 1.5A 5 pole: 4A |
| Protection Degree | IEC IP67 | |
| Material Nut | Zinc die cast | Brass |
| Jacket Material | PolyVinyl Chloride (PVC) | N/A |
| Housing Material | Zinc die cast | Cupboard lead through male to female |
| Contacts Material | Copper-tin(CuSn)=Brass | |
| Conductors Cross Section (AWG) | 0.34 mm ² (22 AWG) 0.25 mm ² (24 AWG) | N/A |
| Mounting Hole Diameter | 16.1 mm; maximum mounting material thickness: 4.5 mm | |
| Tightening Torque | 6.25 Nm | |
| Ø Outer Cable | 5.2 mm | N/A |
| Temperature Range | -25° to +70°C (-13° to 158°F) | -25° to +90°C (-13° to 194°F) |
| Agency Approvals | RoHS | |

Bulkhead Connectors

Dimensions

mm [inches]

Figure 1

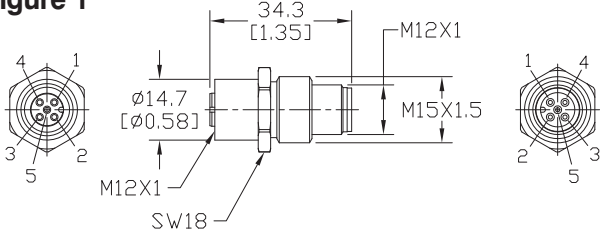

Figure 2

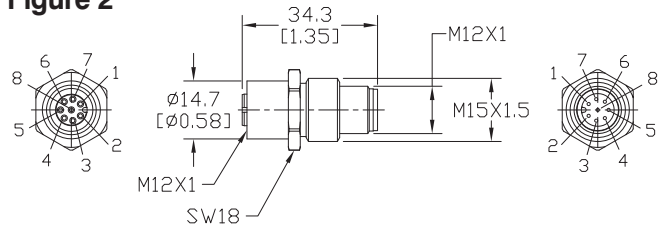

Figure 3

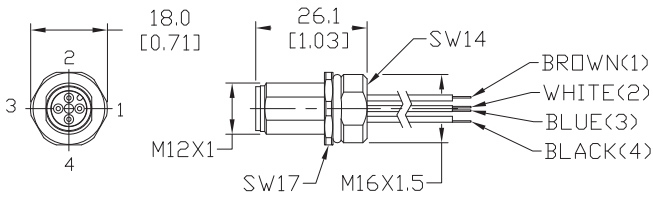

Figure 4

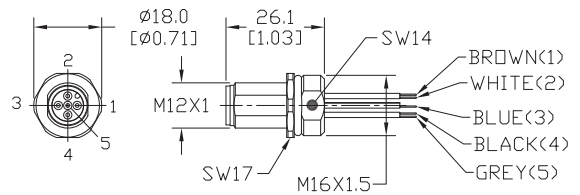

Figure 5

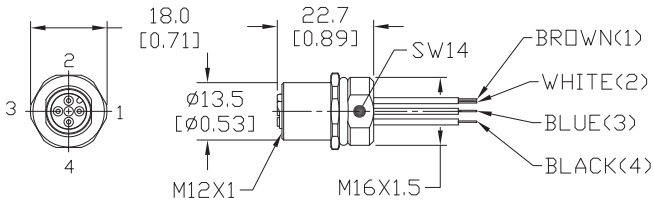

Figure 6

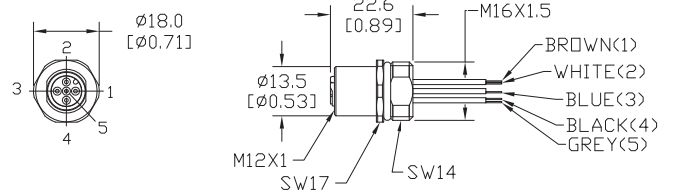

Figure 7

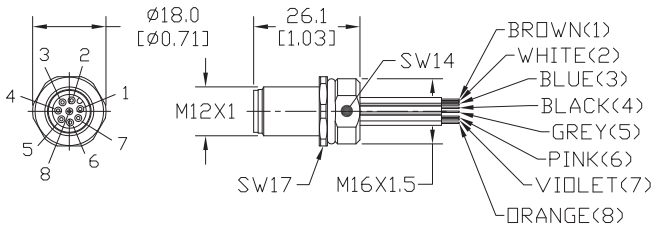
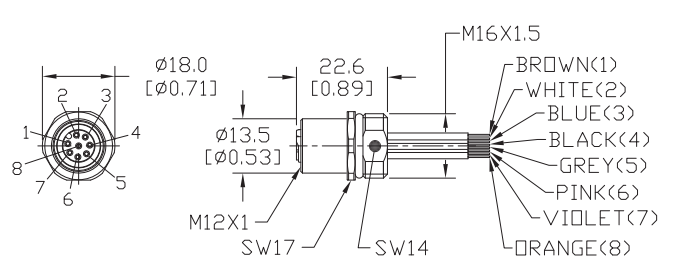

Figure 8



M12 Junction Blocks – Specifications



Note: 2 port caps for unused ports are included.



Overview

ZIPport multi-port interconnection junction blocks provide a simple and effective way to organize machine wiring for a variety of control systems, such as packaging equipment and conveying systems. These systems typically have many I/O points,

such as sensors or solenoid-operated valves, consolidated in one location. Many times these devices are hardwired to a junction box or separately wired back to the main control cabinet. ZIPport multi-port junction blocks provide a more efficient and cost-effective solution: a main homerun control cable is run back to the

main control cabinet, so the cost associated with errors in wiring, rewiring, and I/O replacement is greatly reduced. The designer can choose from a variety of circuit configurations in industry standard M12-style connection, in port configurations of 4-, 6- and 8-pole, with a choice of one I/O per port or two I/O per port.

| ZIPport Junction Block Specifications | | | |
|--|--|--|---|
| Electrical Specifications | | | |
| Voltage Rating | Without LEDs: 0 to 150 V AC/DC max. With LEDs: 48 VDC max, in accordance with LED Configuration | | |
| Current Rating | 3 A per connector, 8 A per block | | |
| Technical Specifications | | | |
| Agency Approvals | UL file E328610, RoHS compliant | | |
| Degree of Protection | IP 67, with proper field wiring cable and all ports being used or covered with a protective cap. | | |
| Operating Temperature Range | -20°C to +80°C (-4°F to 176°F) | | |
| Material Specifications | | | |
| Body | Polypropylene | | |
| Inserts | Polyamide | | |
| Coupling Nuts | 4, 6, and 8-Port: PBT | | |
| Screws | Two m3x0.5x14 screws are used to assemble backshell. | | |
| O-Ring | BUNA-N | | |
| Cable Gland | M20x1.5 | | |
| Recommended Cable Diameters for Field Wireable | <table border="0" style="width: 100%;"> <tr> <td style="width: 50%; vertical-align: top;"> With inner grommet intact: <ul style="list-style-type: none"> • Max OD: 0.31" [7.9mm]. • Min OD: For PUR Cable 0.19" [4.8mm], For PVC Cable 0.17" [4.3mm] </td> <td style="width: 50%; vertical-align: top;"> With inner grommet removed: <ul style="list-style-type: none"> • Max OD: 0.49" [12.5mm]. • Min OD: For PUR Cable 0.28" [7.2mm], -For PVC cable 0.28" [7.2mm], -For SJT/SJE/ST/SE Cable 0.305" [7.75mm] </td> </tr> </table> | With inner grommet intact: <ul style="list-style-type: none"> • Max OD: 0.31" [7.9mm]. • Min OD: For PUR Cable 0.19" [4.8mm], For PVC Cable 0.17" [4.3mm] | With inner grommet removed: <ul style="list-style-type: none"> • Max OD: 0.49" [12.5mm]. • Min OD: For PUR Cable 0.28" [7.2mm], -For PVC cable 0.28" [7.2mm], -For SJT/SJE/ST/SE Cable 0.305" [7.75mm] |
| With inner grommet intact: <ul style="list-style-type: none"> • Max OD: 0.31" [7.9mm]. • Min OD: For PUR Cable 0.19" [4.8mm], For PVC Cable 0.17" [4.3mm] | With inner grommet removed: <ul style="list-style-type: none"> • Max OD: 0.49" [12.5mm]. • Min OD: For PUR Cable 0.28" [7.2mm], -For PVC cable 0.28" [7.2mm], -For SJT/SJE/ST/SE Cable 0.305" [7.75mm] | | |
| LED Lens | Polycarbonate | | |
| Contacts | Copper Alloy with Gold Plating | | |
| Marker Tags | Polyamide (supplied on all units) | | |
| Accessories | 2 port caps for unused ports included. Purchase additional caps (in packs of 5) separately. | | |

- Company Information
- Systems Overview
- Programmable Controllers
- Field I/O
- Software
- C-more & other HMI
- Drives
- Soft Starters
- Motors & Gearbox
- Steppers/Servos
- Motor Controls
- Proximity Sensors
- Photo Sensors
- Limit Switches
- Encoders
- Current Sensors
- Pressure Sensors
- Temperature Sensors
- Pushbuttons/Lights
- Process
- Relays/Timers
- Comm.
- Terminal Blocks & Wiring
- Power
- Circuit Protection
- Enclosures
- Tools
- Pneumatics
- Safety
- Appendix
- Product Index
- Part # Index



M12 Junction Blocks – Selection



ZIP-JBH85-N2-5 shown

| ZIPport M12 Series Selection Chart | | | | | | | | | | | |
|------------------------------------|-------|---------|----------------------------------|-----------------|----------------|---------------------|------------------------------|-------------|---------------|------------|--|
| Part Number | Price | Ports | Wire/Pins | Indicating LEDs | I/O per Socket | Rating per Socket | Home Run Connection Type | Wiring | Pin Out Table | Dimensions | Accessories |
| 4 Port | | | | | | | | | | | |
| ZIP-JBH44-00-FW | <---> | 4 | 4/5 | No LED | 1 | 150V AC/DC max, 3 A | cable clamp for field wiring | Diagram 1-A | – | Figure 1 | ZIP-JBH-CAP CDP12-0B-010-AA CDP12-0B-030-AA CDP12-0B-010-BB CDP12-0B-030-BB |
| ZIP-JBH44-2P-FW | <---> | | | PNP | 1 | 48V DC max, 3 A | cable clamp for field wiring | Diagram 1-B | – | Figure 1 | |
| ZIP-JBH44-2N-FW | <---> | | | NPN | 1 | 48V DC max, 3 A | cable clamp for field wiring | Diagram 1-C | – | Figure 1 | |
| ZIP-JBH44-00-5 | <---> | | | No LED | 1 | 150V AC/DC max, 3 A | 5-meter integrated cable | Diagram 1-A | Table 1 | Figure 1 | |
| ZIP-JBH44-2P-5 | <---> | | | PNP | 1 | 48V DC max, 3 A | 5-meter integrated cable | Diagram 1-B | Table 1 | Figure 1 | |
| ZIP-JBH44-2N-5 | <---> | | | NPN | 1 | 48V DC max, 3 A | 5-meter integrated cable | Diagram 1-C | Table 1 | Figure 1 | |
| ZIP-JBH45-00-FW | <---> | | 5/5 | No LED | 2 | 150V AC/DC max, 3 A | cable clamp for field wiring | Diagram 2-A | – | Figure 2 | |
| ZIP-JBH45-2P-FW | <---> | | | PNP | 2 | 48V DC max, 3 A | cable clamp for field wiring | Diagram 2-B | – | Figure 2 | |
| ZIP-JBH45-2N-FW | <---> | | | NPN | 2 | 48V DC max, 3 A | cable clamp for field wiring | Diagram 2-C | – | Figure 2 | |
| ZIP-JBH45-00-5 | <---> | | | No LED | 2 | 150V AC/DC max, 3 A | 5-meter integrated cable | Diagram 2-A | Table 2 | Figure 2 | |
| ZIP-JBH45-2P-5 | <---> | | | PNP | 2 | 48V DC max, 3 A | 5-meter integrated cable | Diagram 2-B | Table 2 | Figure 2 | |
| ZIP-JBH45-2N-5 | <---> | | | NPN | 2 | 48V DC max, 3 A | 5-meter integrated cable | Diagram 2-C | Table 2 | Figure 2 | |
| 6 Port | | | | | | | | | | | |
| ZIP-JBH64-00-FW | <---> | 6 | 4/5 | No LED | 1 | 150V AC/DC max, 3 A | cable clamp for field wiring | Diagram 3-A | – | Figure 3 | ZIP-JBH-CAP CDP12-0B-010-AA CDP12-0B-030-AA CDP12-0B-010-BB CDP12-0B-030-BB |
| ZIP-JBH64-2P-FW | <---> | | | PNP | 1 | 48V DC max, 3 A | cable clamp for field wiring | Diagram 3-B | – | Figure 3 | |
| ZIP-JBH64-2N-FW | <---> | | | NPN | 1 | 48V DC max, 3 A | cable clamp for field wiring | Diagram 3-C | – | Figure 3 | |
| ZIP-JBH64-00-5 | <---> | | | No LED | 1 | 150V AC/DC max, 3 A | 5-meter integrated cable | Diagram 3-A | Table 3 | Figure 3 | |
| ZIP-JBH64-2P-5 | <---> | | | PNP | 1 | 48V DC max, 3 A | 5-meter integrated cable | Diagram 3-B | Table 3 | Figure 3 | |
| ZIP-JBH64-2N-5 | <---> | | | NPN | 1 | 48V DC max, 2 A | 5-meter integrated cable | Diagram 3-C | Table 3 | Figure 3 | |
| ZIP-JBH65-00-FW | <---> | | 5/5 | No LED | 2 | 150V AC/DC max, 3 A | cable clamp for field wiring | Diagram 4-A | – | Figure 4 | |
| ZIP-JBH65-2P-FW | <---> | | | PNP | 2 | 48V DC max, 3 A | cable clamp for field wiring | Diagram 4-B | – | Figure 4 | |
| ZIP-JBH65-2N-FW | <---> | | | NPN | 2 | 48V DC max, 3 A | cable clamp for field wiring | Diagram 4-C | – | Figure 4 | |
| ZIP-JBH65-00-5 | <---> | | | No LED | 2 | 150V AC/DC max, 3 A | 5-meter integrated cable | Diagram 4-A | Table 4 | Figure 4 | |
| ZIP-JBH65-2P-5 | <---> | | | PNP | 2 | 48V DC max, 3 A | 5-meter integrated cable | Diagram 4-B | Table 4 | Figure 4 | |
| ZIP-JBH65-2N-5 | <---> | | | NPN | 2 | 48V DC max, 3 A | 5-meter integrated cable | Diagram 4-C | Table 4 | Figure 4 | |
| 8 Port | | | | | | | | | | | |
| ZIP-JBH84-00-FW | <---> | 8 | 4/5 | No LED | 1 | 150V AC/DC max, 3 A | cable clamp for field wiring | Diagram 5-A | – | Figure 5 | ZIP-JBH-CAP CDP12-0B-010-AA CDP12-0B-030-AA CDP12-0B-010-BB CDP12-0B-030-BB |
| ZIP-JBH84-2P-FW | <---> | | | PNP | 1 | 48V DC max, 3 A | cable clamp for field wiring | Diagram 5-B | – | Figure 5 | |
| ZIP-JBH84-2N-FW | <---> | | | NPN | 1 | 48V DC max, 3 A | cable clamp for field wiring | Diagram 5-C | – | Figure 5 | |
| ZIP-JBH84-00-5 | <---> | | | No LED | 1 | 150V AC/DC max, 3 A | 5-meter integrated cable | Diagram 5-A | Table 5 | Figure 5 | |
| ZIP-JBH84-2P-5 | <---> | | | PNP | 1 | 48V DC max, 3 A | 5-meter integrated cable | Diagram 5-B | Table 5 | Figure 5 | |
| ZIP-JBH84-2N-5 | <---> | | | NPN | 1 | 48V DC max, 3 A | 5-meter integrated cable | Diagram 5-C | Table 5 | Figure 5 | |
| ZIP-JBH85-00-FW | <---> | | 5/5 | No LED | 2 | 150V AC/DC max, 3 A | cable clamp for field wiring | Diagram 6-A | – | Figure 6 | |
| ZIP-JBH85-2P-FW | <---> | | | PNP | 2 | 48V DC max, 3 A | cable clamp for field wiring | Diagram 6-B | – | Figure 6 | |
| ZIP-JBH85-2N-FW | <---> | | | NPN | 2 | 48V DC max, 3 A | cable clamp for field wiring | Diagram 6-C | – | Figure 6 | |
| ZIP-JBH85-00-5 | <---> | | | No LED | 2 | 150V AC/DC max, 3 A | 5-meter integrated cable | Diagram 6-A | Table 6 | Figure 6 | |
| ZIP-JBH85-2P-5 | <---> | | | PNP | 2 | 48V DC max, 3 A | 5-meter integrated cable | Diagram 6-B | Table 6 | Figure 6 | |
| ZIP-JBH85-2N-5 | <---> | | | NPN | 2 | 48V DC max, 3 A | 5-meter integrated cable | Diagram 6-C | Table 6 | Figure 6 | |
| Accessories | | | | | | | | | | | |
| Part Number | Price | Pcs/Pkg | Description | | | | | | | | Use With |
| ZIP-JBH-CAP | <---> | 5 | Protective cap for unused ports. | | | | | | | |  M12 ZipPort junction blocks |

Wiring Diagrams

4 Port 4 Pin

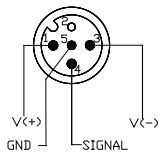

No LED Version
Diagram 1-A

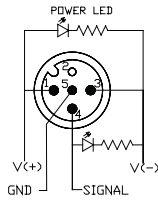

PNP Version
Diagram 1-B

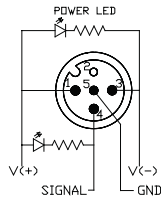

NPN Version
Diagram 1-C

4 Port 5 Pin

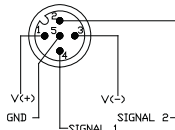

No LED Version
Diagram 2-A

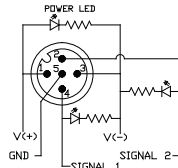

PNP Version
Diagram 2-B

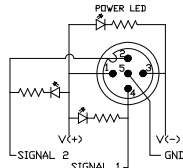

NPN Version
Diagram 2-C

6 Port 4 Pin

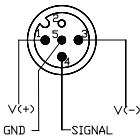

No LED Version
Diagram 3-A

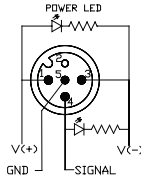

PNP Version
Diagram 3-B

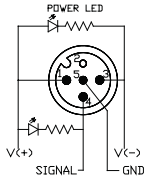

NPN Version
Diagram 3-C

6 Port 5 Pin

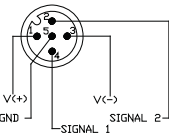

No LED Version
Diagram 4-A

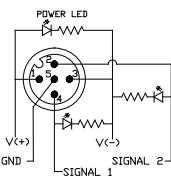

PNP Version
Diagram 4-B

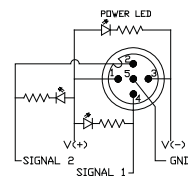

NPN Version
Diagram 4-C

8 Port 4 Pin

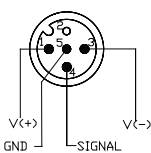

No LED Version
Diagram 5-A

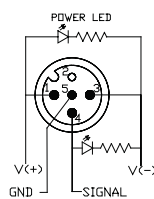

PNP Version
Diagram 5-B

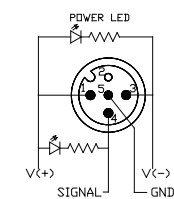

NPN Version
Diagram 5-C

8 Port 5 Pin

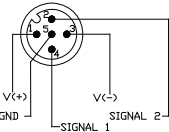

No LED Version
Diagram 6-A

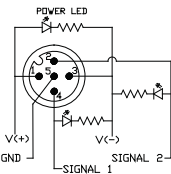

PNP Version
Diagram 6-B

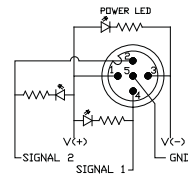

NPN Version
Diagram 6-C

Pin-Out Tables

| Pin Out Table 1 | |
|--------------------------|--------------|
| M12 4 Port 4-Pin ZipPort | |
| Function | Cable O.D. |
| +V | Brown |
| -V | Blue |
| Ground | Green/Yellow |
| Port 1 Pin 4 | White |
| Port 2 Pin 4 | Green |
| Port 3 Pin 4 | Yellow |
| Port 4 Pin 4 | Gray |

| Pin Out Table 2 | |
|--------------------------|--------------|
| M12 4 Port 5-Pin ZipPort | |
| Function | Cable O.D. |
| +V | Brown |
| -V | Blue |
| Ground | Green/Yellow |
| Port 1 Pin 2 | Pink |
| Port 1 Pin 4 | White |
| Port 2 Pin 2 | Red |
| Port 2 Pin 4 | Green |
| Port 3 Pin 2 | Black |
| Port 3 Pin 4 | Yellow |
| Port 4 Pin 2 | Violet |
| Port 4 Pin 4 | Gray |

| Pin Out Table 3 | |
|--------------------------|--------------|
| M12 6 Port 4-Pin ZipPort | |
| Function | Cable O.D. |
| +V | Brown |
| -V | Blue |
| Ground | Green/Yellow |
| Port 1 Pin 4 | White |
| Port 2 Pin 4 | Green |
| Port 3 Pin 4 | Yellow |
| Port 4 Pin 4 | Gray |
| Port 5 Pin 4 | Pink |
| Port 6 Pin 4 | Red |

| Pin Out Table 4 | |
|--------------------------|--------------|
| M12 6 Port 5-Pin ZipPort | |
| Function | Cable O.D. |
| +V | Brown |
| -V | Blue |
| Ground | Green/Yellow |
| Port 1 Pin 2 | Gray/Pink |
| Port 1 Pin 4 | White |
| Port 2 Pin 2 | Red/Blue |
| Port 2 Pin 4 | Green |
| Port 3 Pin 2 | White/Green |
| Port 3 Pin 4 | Yellow |
| Port 4 Pin 2 | Brown/Green |
| Port 4 Pin 4 | Gray |
| Port 5 Pin 2 | White/Yellow |
| Port 5 Pin 4 | Pink |
| Port 6 Pin 2 | Yellow/Brown |
| Port 6 Pin 4 | Red |

| Pin Out Table 5 | |
|--------------------------|--------------|
| M12 8 Port 4-Pin ZipPort | |
| Function | Cable O.D. |
| +V | Brown |
| -V | Blue |
| Ground | Green/Yellow |
| Port 1 Pin 4 | White |
| Port 2 Pin 4 | Green |
| Port 3 Pin 4 | Yellow |
| Port 4 Pin 4 | Gray |
| Port 5 Pin 4 | Pink |
| Port 6 Pin 4 | Red |
| Port 7 Pin 4 | Black |
| Port 8 Pin 4 | Violet |

| Pin Out Table 6 | |
|--------------------------|--------------|
| M12 8 Port 5-Pin ZipPort | |
| Function | Cable O.D. |
| +V | Brown |
| -V | Blue |
| Ground | Green/Yellow |
| Port 1 Pin 2 | Gray/Pink |
| Port 1 Pin 4 | White |
| Port 2 Pin 2 | Red/Blue |
| Port 2 Pin 4 | Green |
| Port 3 Pin 2 | White/Green |
| Port 3 Pin 4 | Yellow |
| Port 4 Pin 2 | Brown/Green |
| Port 4 Pin 4 | Gray |
| Port 5 Pin 2 | White/Yellow |
| Port 5 Pin 4 | Pink |
| Port 6 Pin 2 | Yellow/Brown |
| Port 6 Pin 4 | Red |
| Port 7 Pin 2 | White/Gray |
| Port 7 Pin 4 | Black |
| Port 8 Pin 2 | Gray/Brown |
| Port 8 Pin 4 | Violet |

Note: Pin Out Tables are For 5-meter integrated cable only. Please refer to product insert for field wiring.

ZIPport[®] M12 Junction Blocks – Dimensions

Dimensions

Figure 1: 4 Port 4 Pin

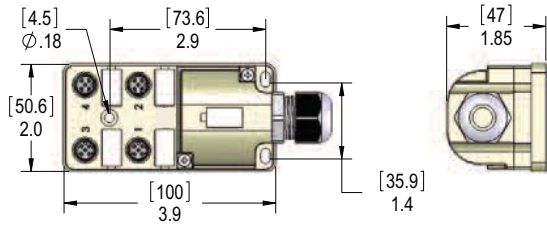

Figure 2: 4 Port 5 Pin

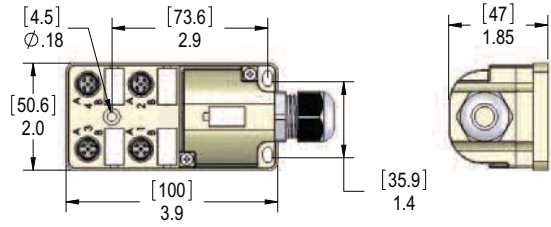

Figure 3: 6 Port 4 Pin

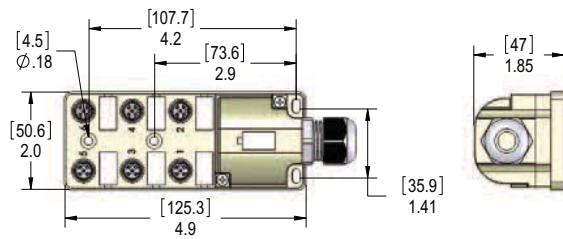

Figure 4: 6 Port 5 Pin

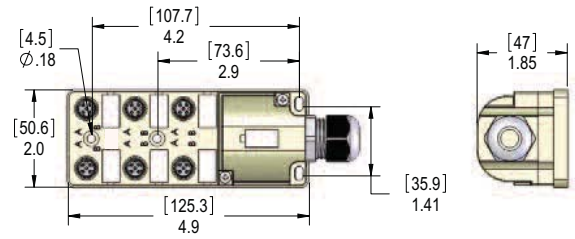

Figure 5: 8 Port 4 Pin

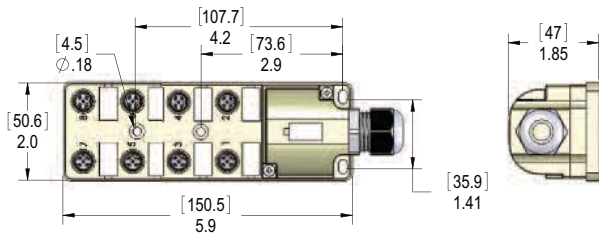
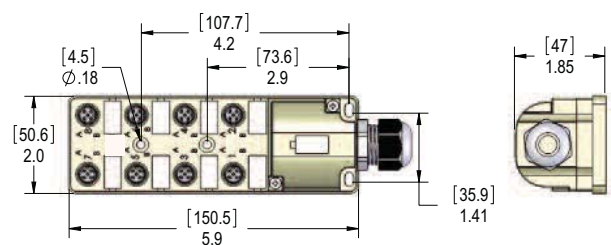

Figure 6: 8 Port 5 Pin



Note: All dimensions are shown in inches [millimeters]



Panel Interface Connectors



Company Information

Systems Overview

Programmable Controllers

Field I/O

Software

C-more & other HMI

Drives

Soft Starters

Motors & Gearbox

Steppers/Servos

Motor Controls

Proximity Sensors

Photo Sensors

Limit Switches

Encoders

Current Sensors

Pressure Sensors

Temperature Sensors

Pushbuttons/Lights

Process

Relays/Timers

Comm.

Terminal Blocks & Wiring

Power

Circuit Protection

Enclosures

Tools

Pneumatics

Safety

Appendix

Product Index

Part #

Index



Overview

What is a Panel Interface Connector?

A panel interface connector (PIC) is a pass-through unit that mounts to the outside of a control panel containing a PLC or other programmable device. Using the pass-through connections, the operator is able to interface with the PLC or other units within the control box without opening the enclosure door. PICs usually contain a power outlet and various connectors necessary for the PLC or other programmable units in the control box. ZipPort PICs are available with single, duplex or GFCI power outlets, as well as a no-power option. Connectors available include D-Sub, RJ45, RJ12, USB, Ethernet, and Data Highway; units are available in various combinations needed for the typical control panel.

Why should I use a Panel Interface Connector?

Installing a PIC on an enclosure allows the operator to access the components inside the enclosure without opening the door. This is an important safety feature which removes many of the risks of working with an open electrical panel. Using a PIC may also eliminate the need for operators to wear fire-resistant suits, hoods and gloves, and use non-conductive tools, prior to accessing electrical enclosures capable of producing Arc Flash*, per NFPA 70E requirements.

***Note: An Arc Flash is a voltage breakdown of resistance of air, resulting in an arc which can occur where there is sufficient voltage in an electrical system and a path to ground or lower voltage.**

Features

- Aluminum housing with gasket
- All connections are normally straight through, pin 1 to pin 1, etc.
- All D-Sub connectors are FEMALE EXTERIOR and MALE INTERIOR referenced to the cabinet.
- The 9-pin D-Sub pin configuration is available as a break out configuration in some units. These connectors allow for the D-Sub to be separated into individual lines. This allows the user to connect to the D-Sub using screw terminal connections.
- Some units are configured for Allen Bradley's®* Data Highway system. In this case, the 9-pin D-Sub and/or 8-pin "mini-DIN" are connected to a 3-pin pluggable terminal block commonly used with "BLUE HOSE" applications.
- The internal power connection for frame sizes 32 and 48 is made via a covered terminal block with spring-type connections.
- The internal power connection for frame sizes 16 and 24 is made via female push-on terminals for Line-in and Neutral, plus a ring terminal for ground.
- The standard reset is a 3 Amp circuit breaker to limit the power output of the unit.

*Registered trademark of Allen Bradley Company, LLC

Agency Approvals

- NEMA / UL Type 12, 4, & 4x
- IP 65
- UL file number E329932
- RoHS compliant





Panel Interface Connectors Specifications

| ZIPport Panel Interface Connectors Specifications | | | | | | |
|--|-------|--------------|--|---|--|--|
| Part Number | Price | Housing Size | Outside Connections (excluding power outlet) | Outside Cable(s) [†] (Table 1) | Inside Connections (excluding power outlet) | Inside Cable(s) [†] (Table 1) |
| The port sequence is exactly the same for outside connections and inside connections. | | | | | | |
| No power | | | | | | |
| ZP-PNA-06-100 | <--> | 6 | Female DB9 | 1, 3 | Male DB9 | 1, 2, 4, 5, 7 |
| ZP-PNA-06-101 | <--> | 6 | RJ45 jack | | RJ45 jack | 8 |
| ZP-PNA-10-200 | <--> | 10 | 2 - Female DB9 | 1, 3 | 2 - Male DB9 | 1, 2, 4, 5, 7 |
| 115V AC Simplex outlet (single) | | | | | | |
| ZP-PSA-16-100 | <--> | 16 | Female DB9 | 1, 3 | Male DB9 | 1, 2, 4, 5, 7 |
| ZP-PSA-16-101 | <--> | 16 | RJ45 jack | | RJ45 jack | 8 |
| ZP-PSA-16-102 | <--> | 16 | RJ12 jack | 4, 5 | RJ12 jack | 4, 5, 7 |
| ZP-PSA-16-103 | <--> | 16 | Female HD15 | | Male HD15 | |
| ZP-PSA-16-104 | <--> | 16 | Female DB15 | 9 | Male DB15 | 9 |
| ZP-PSA-16-200* | <--> | 16 | Female DB9 | 1, 3 | Male DB9 | 1, 2, 4, 5, 7 |
| ZP-PSA-24-100 | <--> | 24 | Female DB25 | | Male DB25 | 10 |
| ZP-PSA-32-300* | <--> | 32 | Female DB9, Female USB Form B | 1, 3, 6 | Male DB9, Female USB form A | 1, 2, 3, 4, 5, 6, 7 |
| ZP-PSA-32-400* | <--> | 32 | 2 - Female DB9, RJ45 jack | 1, 3 | 2 - Male DB9, RJ45 jack | 1, 2, 4, 5, 7, 8 |
| 115V AC Duplex outlet | | | | | | |
| ZP-PDA-32-200* | <--> | 32 | Female DB9 | 1, 3 | Male DB9 | 1, 2, 4, 5, 7 |
| ZP-PDA-32-201* | <--> | 32 | RJ45 jack | | RJ45 jack | 8 |
| ZP-PDA-32-202* | <--> | 32 | Female USB form A | 3 | Female USB form A | 3, 6 |
| ZP-PDA-32-300* | <--> | 32 | Female DB9, RJ45 jack | 1, 3 | Male DB9, RJ45 jack | 1, 2, 4, 5, 7, 8 |
| ZP-PDA-32-301* | <--> | 32 | Female DB9, RJ45 jack | 1, 3 | 9-Pin terminal block, RJ45 jack | 8 |
| ZP-PDA-32-302* | <--> | 32 | Female DB9, Female USB Form B | 1, 3, 6 | Male DB9, Female USB Form A | 1, 2, 3, 4, 5, 6, 7 |
| ZP-PDA-32-303* | <--> | 32 | Female DB9, Female 8-Pin Mini-Din | 1, 3 | 3-pin terminal block, (Data Highway) | |
| ZP-PDA-32-304* | <--> | 32 | Female DB9, RJ45 jack | 1, 3 | 3-pin terminal block, (Data Highway), RJ45 jack | 8 |
| ZP-PDA-32-305* | <--> | 32 | Female DB9, Female USB form A | 1, 3, 6 | Male DB9, Female USB form A | 1, 2, 3, 4, 5, 6, 7 |
| ZP-PDA-32-400* | <--> | 32 | 2 - Female DB9, Female USB form B | 1, 3, 6 | 2 - Male DB9, Female USB form A | 1, 2, 3, 4, 5, 6, 7 |
| ZP-PDA-32-401* | <--> | 32 | Female DB9, Female USB form B, Female USB form A | 1, 3, 6 | Male DB9, Female USB form A, Female USB form B | 1, 2, 3, 4, 5, 6, 7 |
| ZP-PDA-32-402* | <--> | 32 | RJ45 jack, Female USB form B, Female USB form A | 3, 6 | RJ45 jack, Female USB form A, Female USB form B | 3, 6, 8 |
| ZP-PDA-32-403* | <--> | 32 | Female DB9, RJ12 jack, Female USB form A | 1, 3, 4, 5 | Male DB9, RJ12 jack, Female USB form A | 1, 2, 3, 4, 5, 6, 7 |
| 115V AC GFCI outlet | | | | | | |
| ZP-PGA-32-200* | <--> | 32 | Female DB9 | 1, 3 | Male DB9 | 1, 2, 4, 5, 7 |
| ZP-PGA-32-201* | <--> | 32 | RJ45 jack | | RJ45 jack | 8 |
| ZP-PGA-32-300* | <--> | 32 | Female DB9, RJ45 jack | 1, 3 | Male DB9, RJ45 jack | 1, 2, 4, 5, 7, 8 |
| ZP-PGA-32-301* | <--> | 32 | Female DB9, Female USB form B | 1, 3, 6 | Male DB9, Female USB form A | 1, 2, 3, 4, 5, 6, 7 |
| ZP-PGA-48-400* | <--> | 48 | Female DB9, Female USB form B, Female USB form A | 1, 3, 6 | Male DB9, Female USB form A, Female USB form B | 1, 2, 3, 4, 5, 6, 7 |
| ZP-PGA-48-500* | <--> | 48 | 2 - Female DB9, Female USB form B, Female USB form A | 1, 3, 6 | 2 - Male DB9, Female USB form A, Female USB form B | 1, 2, 3, 4, 5, 6, 7 |

[†]Note: Based on application. *Note: 3 Amp resettable circuit breaker. Note: Port sequence for inside connections mirrors port sequence for outside connections

| ZIPport Panel Interface Connectors General Specifications | |
|--|---|
| Electrical Specifications for PICs with Power Outlet(s) | |
| Voltage Rating | 115 VAC |
| Current Rating | 3 A with resettable circuit breaker, 15 A without resettable circuit breaker |
| SCCR | 10 kA |
| Technical Specs | |
| Agency Approvals | UL Recognized, RoHS compliant |
| Degree of Protection | IP65, NEMA/UL 4, 4x, 12 (when mounted with supplied gasket) |
| Suggested Mounting Screw | #8 -32 x 3/4" for housing sizes 6 through 32. #10 - 32 x 3/4" for size 48 Mounting screws not included with product. |
| Suggested Screw Torque | 10.62 lb/in for housing sizes 6 through 32. 17.7 lb/in for housing size 48 |
| Material Specifications | |
| Body | Epoxy-coated Die-cast Aluminum |
| Gasket | Thermo-plastic (TPE) |
| Handle | Polyamide |
| Levers | Stainless Steel |
| Accessories | |
| One gasket supplied and required during mounting to meet Degree of Protection standards. | |
| Insert with Panel Cutout dimensions for mounting | |

| Table 1 | | |
|------------|-------------------|---|
| Cable Code | Cable Part Number | Cable Description |
| 1 | ZL-DB9-CBL-2 | Male DB9 to Female DB9 adapter cable |
| 2 | SVC-PCCFG-CBL | Female DB9 to Female Firewire Servo adapter cable |
| 3 | USB-RS232 | Male USB form A to Male DB9 adapter cable |
| 4 | D2-DSCBL | Programming cable for DL05/06, DL105, DL205, DL350, D4-450, Click |
| 5 | GS-232CBL | RJ12 to Female DB9 for GS2 DRIVES ONLY |
| 6 | USB-CBL-AB_ | USB form A to USB form B cable series |
| 7 | FA-ISOCAN | RS232 - RS422/485 converter |
| 8 | OP-MCBL-1 | Optimate cable for Modbus PLCs |
| 9 | ZL-DB15-CBL-2 | Male DB15 to Female DB15 adapter cable |
| 10 | ZL-DB25-CBL-2 | Male DB25 to Female DB25 adapter cable |

No Power



ZP-PNA-06-100

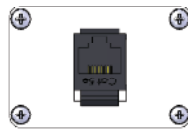

ZP-PNA-06-101

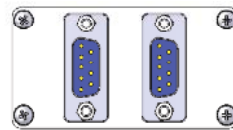

ZP-PNA-10-200

Simplex Outlet, 115V AC



ZP-PSA-16-100

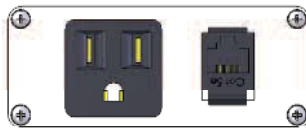

ZP-PSA-16-101

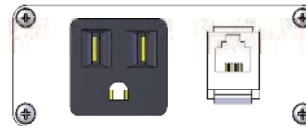

ZP-PSA-16-102

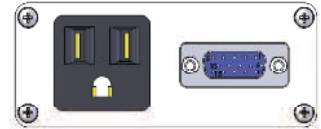

ZP-PSA-16-103

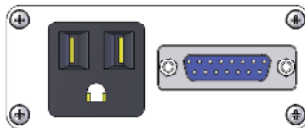

ZP-PSA-16-104



ZP-PSA-16-200

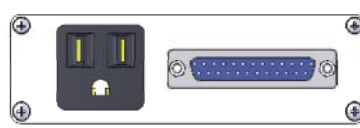

ZP-PSA-24-100

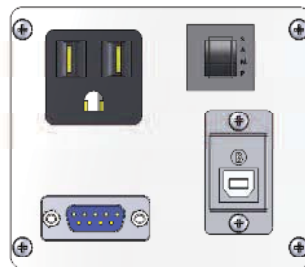

ZP-PSA-32-300

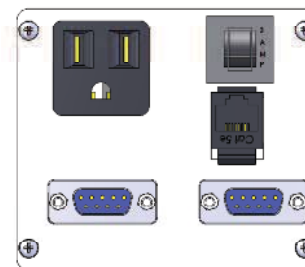

ZP-PSA-32-400



Back view of ZP-PSA-24-100

Crimp terminals are supplied for hot and neutral connection for housing sizes 6 through 24. Ground wire supplied with an M3 ring terminal (recommended screw size #6).

GFCI Outlet, 115V AC

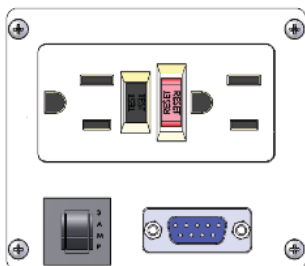

ZP-PGA-32-200

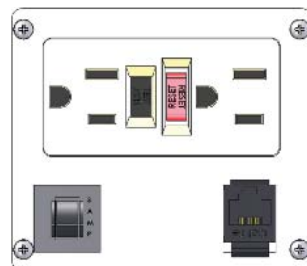

ZP-PGA-32-201

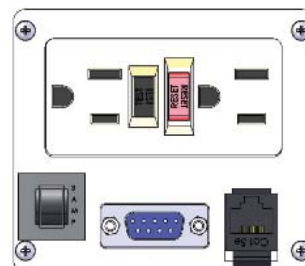

ZP-PGA-32-300

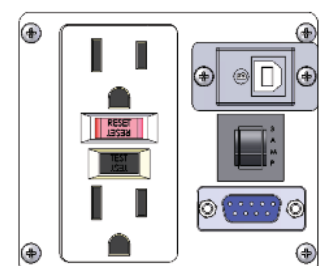

ZP-PGA-32-301

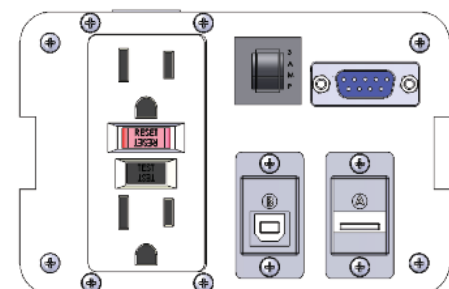

ZP-PGA-48-400

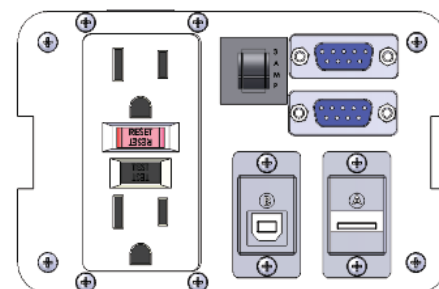

ZP-PGA-48-500



Panel Interface Connectors Face View

Duplex Outlet, 115V AC

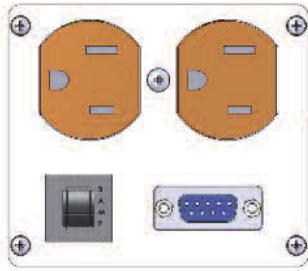

ZP-PDA-32-200

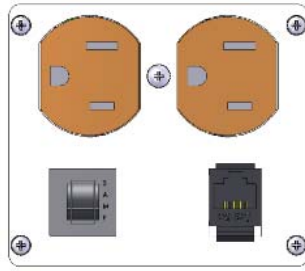

ZP-PDA-32-201

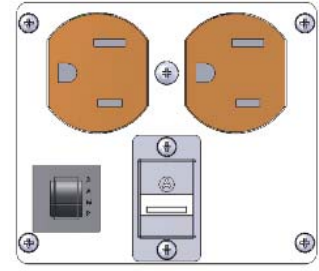

ZP-PDA-32-202

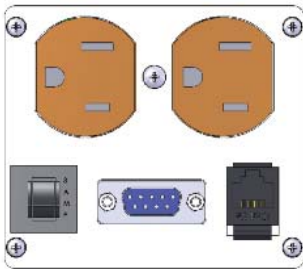

ZP-PDA-32-300

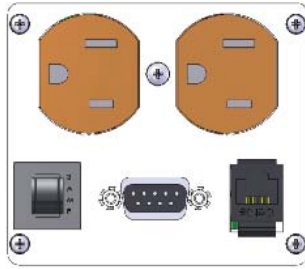

ZP-PDA-32-301

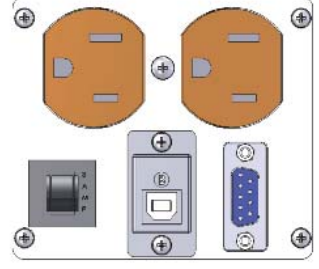

ZP-PDA-32-302

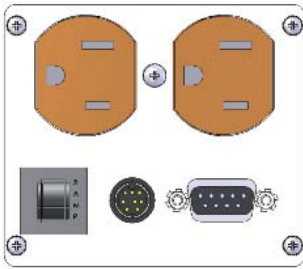

ZP-PDA-32-303

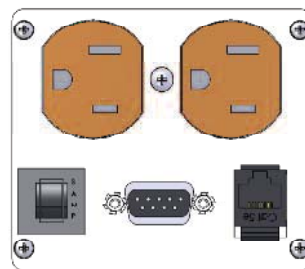

ZP-PDA-32-304

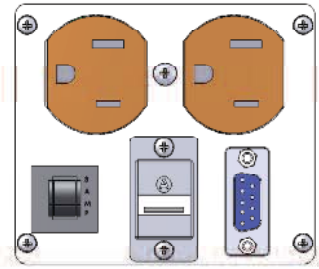

ZP-PDA-32-305

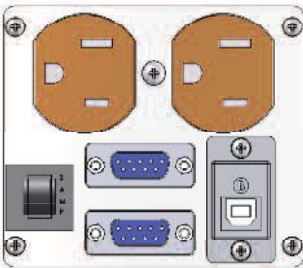

ZP-PDA-32-400

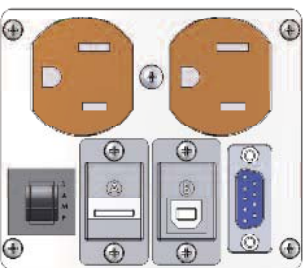

ZP-PDA-32-401

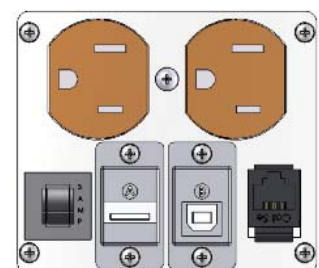

ZP-PDA-32-402

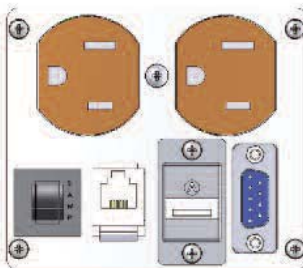

ZP-PDA-32-403



Back view of ZP-PDA-32-401

Power connection through spring-loaded terminal block for housing sizes 32 and 48.

Note: Complete AUTOCAD drawings of these products are available on the Tech Support section of our Web site at AutomationDirect.com.

DB9 Pin Configuration
View looking into Female connector

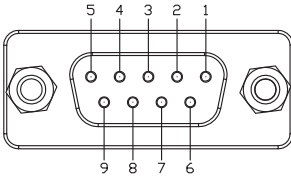

DB15 Pin Configuration
View looking into Female connector

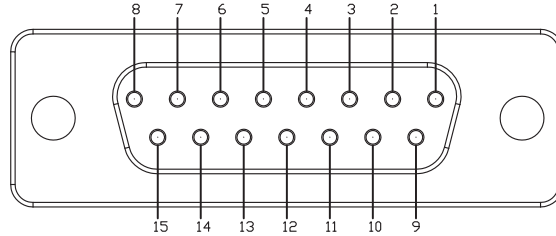

HD15 Pin Configuration
View looking into Female connector

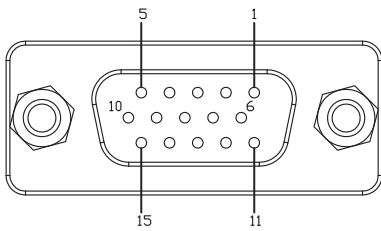

DB25 Pin Configuration
View looking into Female connector

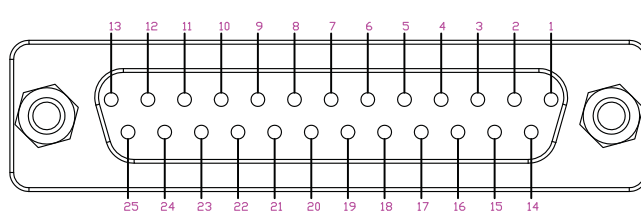

DB9 Data Highway Plus Pin Configuration
View looking into Female connector

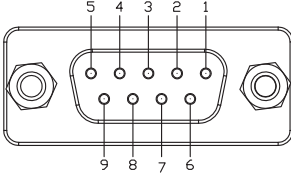

DB9 + 8-Pin Mini-Din Data Highway Plus Pin Configuration
View looking into Female connector

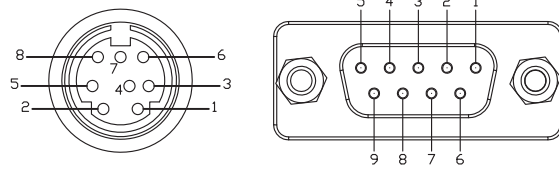

- DB9 to Phoenix 3-Pin connector**
- 1 Clear
 - 5 Blue
 - 7 Shield

- DB9 to Phoenix 3-Pin connector**
- 1 Clear
 - 5 Blue
 - 7 Shield

- 8-Pin Mini to Phoenix 3-Pin connector**
- 1 Blue
 - 3 Shield
 - 6 Clear

RJ45 Pin Configuration

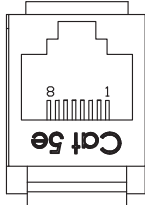

Terminal Block Pin Configuration for Power

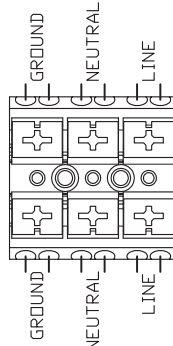

RJ12 Pin Configuration

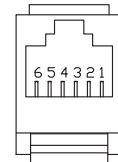



Panel Interface Connectors Quick Reference Chart

Use this checklist to quickly identify the connections in each panel interface connector.

| ZIPport Panel Interface Connectors | | | | | | | | | | | | |
|--|-----|------|------|------|------|------|--------|--------|--------|-----------|---------------------|----------------------------------|
| Part Number | DB9 | DB15 | HD15 | DB25 | RJ12 | RJ45 | USB-AB | USB-BA | USB-AA | 8-Pin DIN | Data Hwy Connection | 3 Amp Resettable Circuit Breaker |
| No power | | | | | | | | | | | | |
| ZP-PNA-06-100 | ✓ | | | | | | | | | | | |
| ZP-PNA-06-101 | | | | | | ✓ | | | | | | |
| ZP-PNA-10-200 | ✓✓ | | | | | | | | | | | |
| 115V AC Simplex outlet (single) | | | | | | | | | | | | |
| ZP-PSA-16-100 | ✓ | | | | | | | | | | | |
| ZP-PSA-16-101 | | | | | | ✓ | | | | | | |
| ZP-PSA-16-102 | | | | | ✓ | | | | | | | |
| ZP-PSA-16-103 | | | ✓ | | | | | | | | | |
| ZP-PSA-16-104 | | ✓ | | | | | | | | | | |
| ZP-PSA-16-200 | ✓ | | | | | | | | | | | ✓ |
| ZP-PSA-24-100 | | | | ✓ | | | | | | | | |
| ZP-PSA-32-300 | ✓ | | | | | | | ✓ | | | | ✓ |
| ZP-PSA-32-400 | ✓✓ | | | | | ✓ | | | | | | ✓ |
| 115V AC Duplex outlet | | | | | | | | | | | | |
| ZP-PDA-32-200 | ✓ | | | | | | | | | | | ✓ |
| ZP-PDA-32-201 | | | | | | ✓ | | | | | | ✓ |
| ZP-PDA-32-202 | | | | | | | | | ✓ | | | ✓ |
| ZP-PDA-32-300 | ✓ | | | | | ✓ | | | | | | ✓ |
| ZP-PDA-32-301* | ✓ | | | | | ✓ | | | | | | ✓ |
| ZP-PDA-32-302 | ✓ | | | | | | | ✓ | | | | ✓ |
| ZP-PDA-32-303 | ✓ | | | | | | | | | ✓ | ✓ | ✓ |
| ZP-PDA-32-304 | ✓ | | | | | ✓ | | | | | ✓ | ✓ |
| ZP-PDA-32-305 | ✓ | | | | | | | | ✓ | | | ✓ |
| ZP-PDA-32-400 | ✓✓ | | | | | | | ✓ | | | | ✓ |
| ZP-PDA-32-401 | ✓ | | | | | | ✓ | ✓ | | | | ✓ |
| ZP-PDA-32-402 | | | | | | ✓ | ✓ | ✓ | | | | ✓ |
| ZP-PDA-32-403 | ✓ | | | | ✓ | | | | ✓ | | | ✓ |
| 115V AC GFCI outlet | | | | | | | | | | | | |
| ZP-PGA-32-200 | ✓ | | | | | | | | | | | ✓ |
| ZP-PGA-32-201 | | | | | | ✓ | | | | | | ✓ |
| ZP-PGA-32-300 | ✓ | | | | | ✓ | | | | | | ✓ |
| ZP-PGA-32-301 | ✓ | | | | | | | ✓ | | | | ✓ |
| ZP-PGA-48-400 | ✓ | | | | | | ✓ | ✓ | | | | ✓ |
| ZP-PGA-48-500 | ✓✓ | | | | | | ✓ | ✓ | | | | ✓ |

* Note: This DB9 becomes a 9-pin terminal block in the back.

Panel Interface Connectors Dimensions

Panel Cutout Dimensions

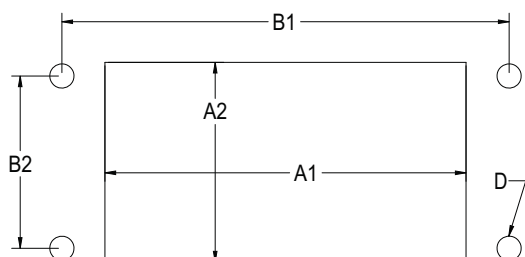

| Panel Cutout Dimensions | | | | | | |
|-------------------------|------|--------------|-------------|--------------|--------------|--------------|
| Part | Size | A1 | A2 | B1 | B2 | D |
| ZP-PNA-06-xxx | 6 | 2.13 [54.1] | 1.46 [37.1] | 2.76 [70.10] | 1.26 [32.00] | 0.177 [4.50] |
| ZP-PNA-10-xxx | 10 | 2.64 [67.1] | 1.46 [37.1] | 3.27 [83.1] | 1.26 [32.00] | 0.177 [4.50] |
| ZP-PSA-16-xxx | 16 | 3.46 [87.9] | 1.46 [37.1] | 4.07 [103.4] | 1.26 [32.00] | 0.177 [4.50] |
| ZP-PSA-24-xxx | 24 | 4.10 [104.1] | 1.46 [37.1] | 5.12 [130.0] | 1.26 [32.00] | 0.177 [4.50] |
| ZP-PSA-32-xxx | 32 | 3.46 [87.9] | 2.99 [75.9] | 4.33 [110.0] | 2.56 [65.0] | 0.177 [4.50] |
| ZP-PDA-32-xxx | 32 | 3.46 [87.9] | 2.99 [75.9] | 4.33 [110.0] | 2.56 [65.0] | 0.177 [4.50] |
| ZP-PGA-32-xxx | 32 | 3.46 [87.9] | 2.99 [75.9] | 4.33 [110.0] | 2.56 [65.0] | 0.177 [4.50] |
| ZP-PGA-48-xxx | 48 | 4.92 [125.0] | 3.19 [81.0] | 5.83 [148.1] | 2.76 [70.10] | 0.256 [6.50] |

Housing Dimensions

Note: All dimensions in inches [millimeters]

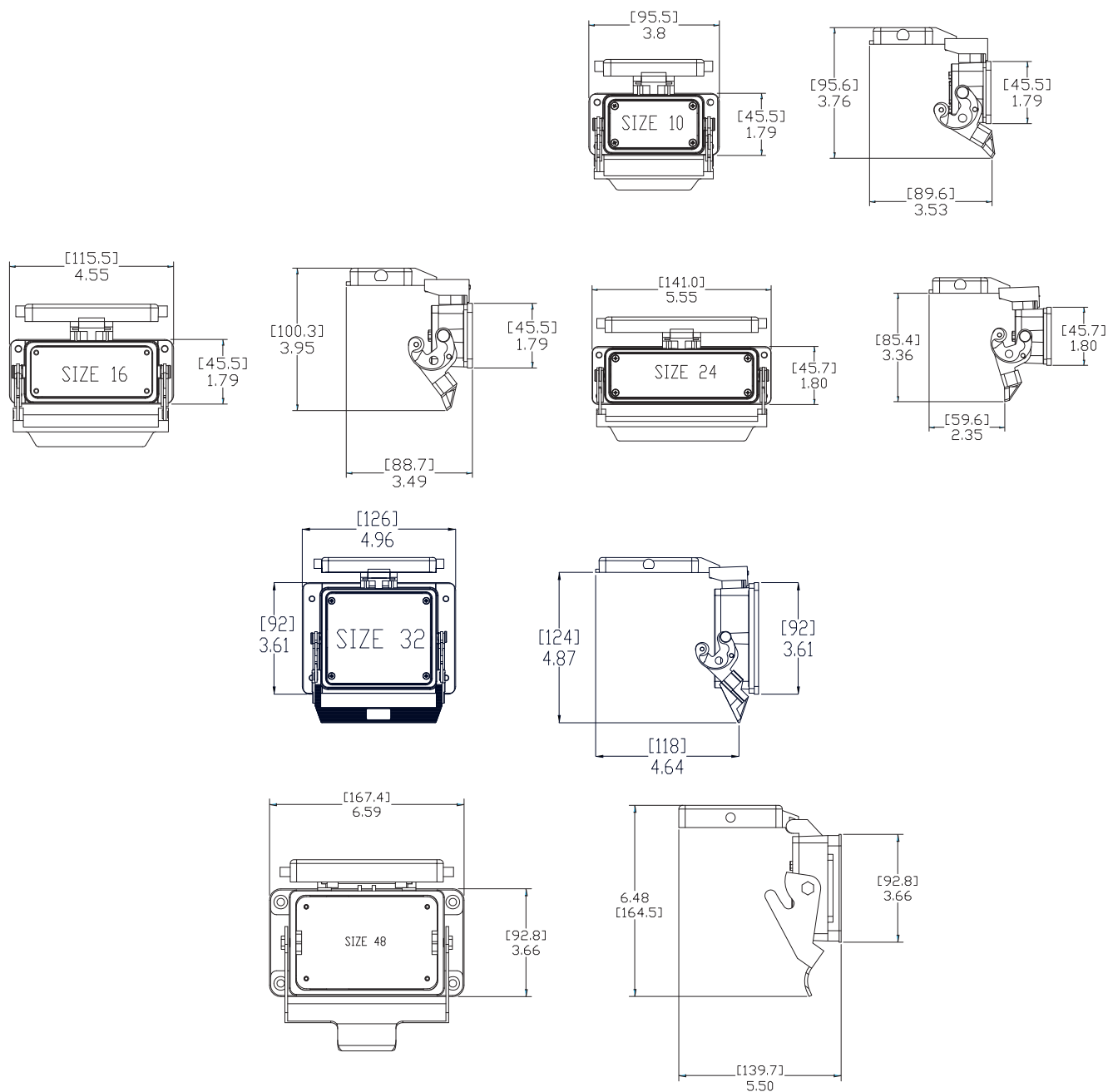

Wiring Solutions Overview

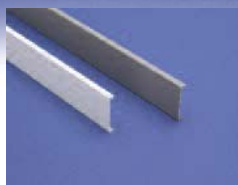
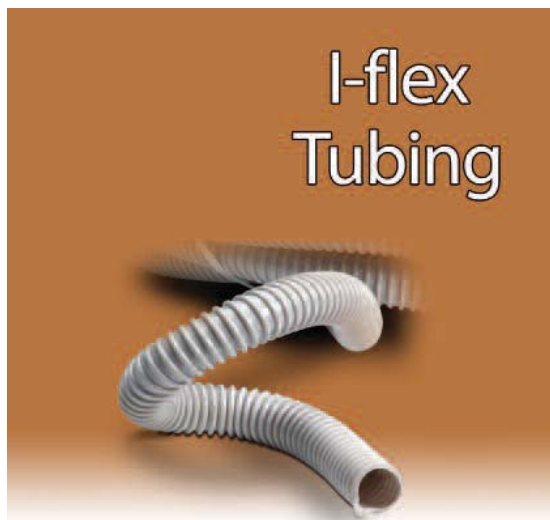
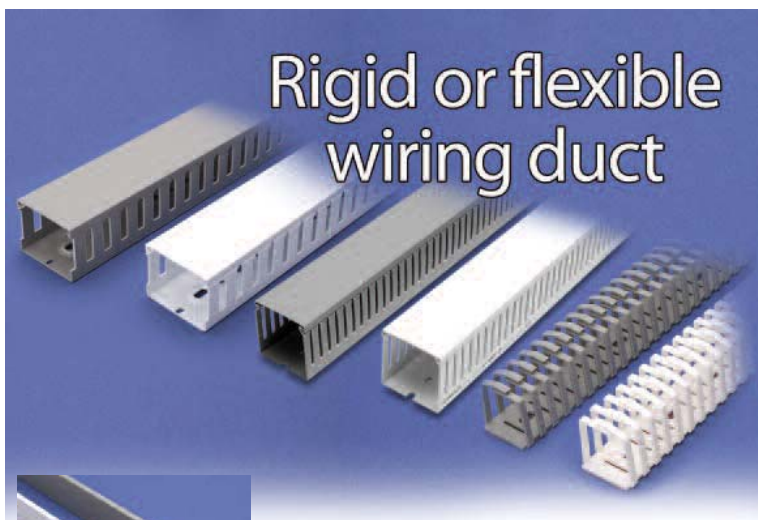

Duct Cover Included

Braided Sleeving

This lightweight polyester sleeving has an open weave to allow a maximum range of diameter expansion



AutomationDirect offers rigid wiring duct in a variety of sizes and styles for all your panel wiring needs. The T1 (standard) and T1E (thin finger) series open-slot rigid duct, and TSH (solid) series are made of PVC and carry a UL 94V-0 flammability rating. All styles are available in standard gray and white. The T1 series is also available in blue and black, for specialized wiring identification. Using blue wiring duct indicates the wiring inside runs to intrinsically safe (meaning where safety is essential) components in a control panel. Control panels used in chemical plants, grain elevators or other environments where explosive gases may exist are examples of intrinsic blue duct applications. The black wire duct was introduced as a product for the data communication industry. Network cabling systems, fiber cable racks, patch panels and telecommunication closets, are examples of applications for the black wire duct. All duct is sold in 2 meter lengths, complete with covers, in convenient multi-piece packages or by the piece.

DINOSAUR flexible wiring duct is self-adhesive, and can be bent and twisted without breaking. Wiring duct accessories include spiral wrap, braided sleeving, replacement rigid duct covers, and mounting and labeling accessories.



Spiral Wrap

Neatly group wire bundles simply and economically



I-Flex leak-proof, flexible, electrical conduit tubing can be used in extremely tight quarters, thanks to its flexibility. It is just right for basic applications where fast installation and maximum flexibility are a must, and is the solution in areas where movement, vibration, or flexing can be a problem. This tubing provides excellent tensile strength and the smooth interior wall protects wiring. All models are available in light gray or black.



Duct Separators



Wire Retainers

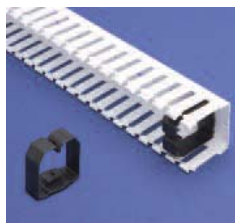

Identification Tags



Mounting Inserts

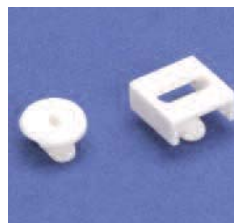

Rivets & Rivet Tools



Wiring Duct – T1 Series - Slotted

Overview

Rugged wiring duct made of rigid PVC carries a UL 94V-0 flammability rating for your wire containment needs. All our wiring duct comes in 6.56 feet (2 meter) lengths, complete with cover. Replacement duct covers can be purchased separately.

Features

- Standard mounting holes
- Wide finger design provides greater rigidity and larger slot width
- Rounded, burr-free edges will not cut installers' hands or insulation
- Non-slip cover
- Flush cover design holds 10% -12% more wires than traditional designs
- Restricted slot design for fast and easy wire installation/removal
- Two predetermined break lines, one for breaking off and removal of sidewall finger segments only, and another for removal of sidewall finger and base segments
- Patented recess boss for fast mounting of components
- Intrinsic Blue color per ISA-RD12.6 (Instrument Society of America)
- Black color to complement the look of historically black telecommunications racks and hardware
- Temperature range -15 °C to +50 °C max.

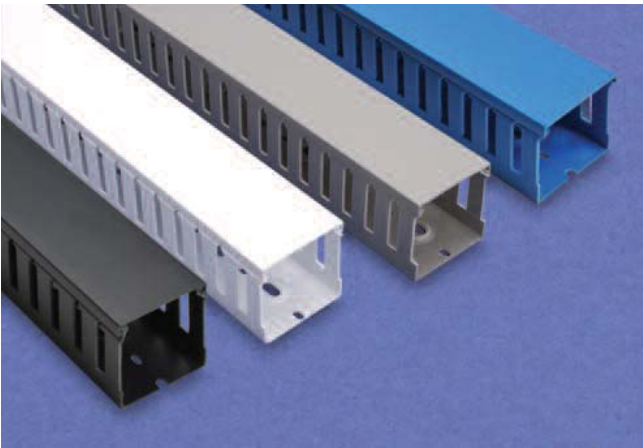

UL file E123572



| T1 Series Gray Open Slot Rigid PVC (including cover) | | | | | |
|--|------------------|-------|---------------------------------|------------------|-------|
| Catalog Number Standard Carton | Package Quantity | Price | Catalog Number Single Piece Pkg | Package Quantity | Price |
| T1-0506G | 20 | <--> | T1-0506G-1 | 1 | <--> |
| T1-0510G | 20 | <--> | T1-0510G-1 | 1 | <--> |
| T1-1010G | 18 | <--> | T1-1010G-1 | 1 | <--> |
| T1-1015G | 18 | <--> | T1-1015G-1 | 1 | <--> |
| T1-1022G | 24 | <--> | T1-1022G-1 | 1 | <--> |
| T1-1030G | 24 | <--> | T1-1030G-1 | 1 | <--> |
| T1-1040G | 8 | <--> | T1-1040G-1 | 1 | <--> |
| T1-1515G | 20 | <--> | T1-1515G-1 | 1 | <--> |
| T1-1522G | 18 | <--> | T1-1522G-1 | 1 | <--> |
| T1-1530G | 16 | <--> | T1-1530G-1 | 1 | <--> |
| T1-1540G | 8 | <--> | T1-1540G-1 | 1 | <--> |
| T1-2215G | 12 | <--> | T1-2215G-1 | 1 | <--> |
| T1-2222G | 12 | <--> | T1-2222G-1 | 1 | <--> |
| T1-2230G | 12 | <--> | T1-2230G-1 | 1 | <--> |
| T1-2240G | 4 | <--> | T1-2240G-1 | 1 | <--> |
| T1-3015G | 12 | <--> | T1-3015G-1 | 1 | <--> |
| T1-3022G | 12 | <--> | T1-3022G-1 | 1 | <--> |
| T1-3030G | 12 | <--> | T1-3030G-1 | 1 | <--> |
| T1-3040G | 4 | <--> | T1-3040G-1 | 1 | <--> |
| T1-3050G | 6 | <--> | T1-3050G-1 | 1 | <--> |
| T1-4015G | 8 | <--> | T1-4015G-1 | 1 | <--> |
| T1-4022G | 8 | <--> | T1-4022G-1 | 1 | <--> |
| T1-4030G | 8 | <--> | T1-4030G-1 | 1 | <--> |
| T1-4040G | 4 | <--> | T1-4040G-1 | 1 | <--> |
| T1-4050G | 4 | <--> | T1-4050G-1 | 1 | <--> |
| T1-6040G | 4 | <--> | T1-6040G-1 | 1 | <--> |

| T1 Series Black Open Slot Rigid PVC (including cover) | | | | | |
|---|------------------|-------|---------------------------------|------------------|-------|
| Catalog Number Standard Carton | Package Quantity | Price | Catalog Number Single Piece Pkg | Package Quantity | Price |
| T1-1040K | 8 | <--> | T1-1040K-1 | 1 | <--> |
| T1-1530K | 16 | <--> | T1-1530K-1 | 1 | <--> |
| T1-2222K | 12 | <--> | T1-2222K-1 | 1 | <--> |
| T1-2240K | 4 | <--> | T1-2240K-1 | 1 | <--> |
| T1-3030K | 12 | <--> | T1-3030K-1 | 1 | <--> |
| T1-3040K | 4 | <--> | T1-3040K-1 | 1 | <--> |
| T1-3050K | 6 | <--> | T1-3050K-1 | 1 | <--> |
| T1-4040K | 4 | <--> | T1-4040K-1 | 1 | <--> |
| T1-4050K | 4 | <--> | T1-4050K-1 | 1 | <--> |

| T1 Series White Open Slot Rigid PVC (including cover) | | | | | |
|---|------------------|-------|---------------------------------|------------------|-------|
| Catalog Number Standard Carton | Package Quantity | Price | Catalog Number Single Piece Pkg | Package Quantity | Price |
| T1-1010W | 18 | <--> | T1-1010W-1 | 1 | <--> |
| T1-1015W | 18 | <--> | T1-1015W-1 | 1 | <--> |
| T1-1022W | 24 | <--> | T1-1022W-1 | 1 | <--> |
| T1-1030W | 24 | <--> | T1-1030W-1 | 1 | <--> |
| T1-1040W | 8 | <--> | T1-1040W-1 | 1 | <--> |
| T1-1515W | 20 | <--> | T1-1515W-1 | 1 | <--> |
| T1-1522W | 18 | <--> | T1-1522W-1 | 1 | <--> |
| T1-1530W | 16 | <--> | T1-1530W-1 | 1 | <--> |
| T1-1540W | 8 | <--> | T1-1540W-1 | 1 | <--> |
| T1-2222W | 12 | <--> | T1-2222W-1 | 1 | <--> |
| T1-2230W | 12 | <--> | T1-2230W-1 | 1 | <--> |
| T1-2240W | 4 | <--> | T1-2240W-1 | 1 | <--> |
| T1-3022W | 12 | <--> | T1-3022W-1 | 1 | <--> |
| T1-3030W | 12 | <--> | T1-3030W-1 | 1 | <--> |
| T1-3040W | 4 | <--> | T1-3040W-1 | 1 | <--> |
| T1-3050W | 6 | <--> | T1-3050W-1 | 1 | <--> |
| T1-4022W | 8 | <--> | T1-4022W-1 | 1 | <--> |
| T1-4030W | 8 | <--> | T1-4030W-1 | 1 | <--> |
| T1-4040W | 4 | <--> | T1-4040W-1 | 1 | <--> |
| T1-4050W | 4 | <--> | T1-4050W-1 | 1 | <--> |
| T1-6040W | 4 | <--> | T1-6040W-1 | 1 | <--> |

| T1 Series Blue Open Slot Rigid PVC (including cover) | | | | | |
|--|------------------|-------|---------------------------------|------------------|-------|
| Catalog Number Standard Carton | Package Quantity | Price | Catalog Number Single Piece Pkg | Package Quantity | Price |
| T1-1010B | 18 | <--> | T1-1010B-1 | 1 | <--> |
| T1-1022B | 24 | <--> | T1-1022B-1 | 1 | <--> |
| T1-1030B | 24 | <--> | T1-1030B-1 | 1 | <--> |
| T1-1515B | 20 | <--> | T1-1515B-1 | 1 | <--> |
| T1-1522B | 18 | <--> | T1-1522B-1 | 1 | <--> |
| T1-1530B | 16 | <--> | T1-1530B-1 | 1 | <--> |
| T1-2215B | 12 | <--> | T1-2215B-1 | 1 | <--> |
| T1-2222B | 12 | <--> | T1-2222B-1 | 1 | <--> |
| T1-2230B | 12 | <--> | T1-2230B-1 | 1 | <--> |
| T1-3030B | 12 | <--> | T1-3030B-1 | 1 | <--> |
| T1-4030B | 8 | <--> | T1-4030B-1 | 1 | <--> |
| T1-4040B | 4 | <--> | T1-4040B-1 | 1 | <--> |

Wiring Duct – T1 Series

Restricted slot opening for wire retaining

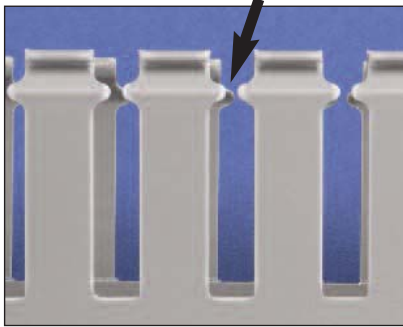

Recess boss for rapid mounting of components

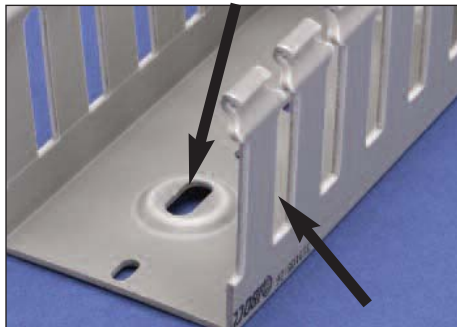

Two pre-determined breaklines

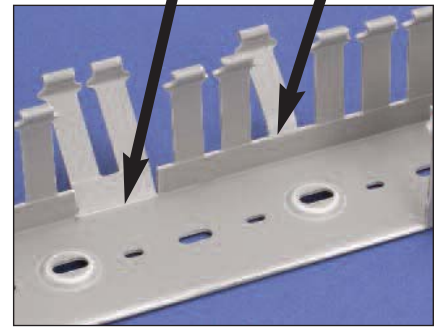

Burr-free edges

Dimensions

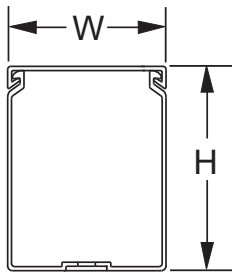

Nominal 5/8" - 1"

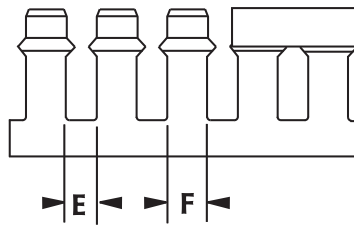

Nominal 1 1/2" - 2 1/4" - 3" - 4"

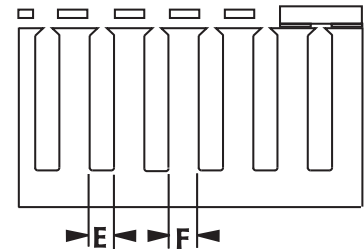

| Open Slot Rigid PVC (including cover) Dimensions | | | | |
|--|---------------------|-------------------------------|-------------------------|-------------------------|
| Nominal Size (WxH) inches (mm) | Catalog Part Number | Actual Size (WxH) inches (mm) | Dimension E inches (mm) | Dimension F inches (mm) |
| 0.50 x .625 (12.7 x 15.88) | T1-0506G | 0.60 x .7 (15 x 18) | 0.20 (5.08) | 0.30 (7.62) |
| 0.50 x 1.00 (12.7 x 25.4) | T1-0510G | 0.60 x 1.18 (15 x 30) | | |
| 1.00 x 1.00 (25.4 x 25.4) | T1-1010*• | 1.00 x 1.18 (25 x 30) | | |
| 1.00 x 1.50 (25.4 x 38.1) | T1-1015* | 1.00 x 1.57 (25 x 40) | 0.31 (7.87) | 0.47 (11.94) |
| 1.00 x 2.25 (25.4 x 57.15) | T1-1022*• | 1.00 x 2.36 (25 x 60) | | |
| 1.00 x 3.00 (25.4 x 76.2) | T1-1030*• | 1.00 x 3.15 (25 x 80) | | |
| 1.00 x 4.00 (25.4 x 101.6) | T1-1040*† | 1.00 x 3.94 (25 x 100) | | |
| 1.50 x 1.50 (38.1 x 38.1) | T1-1515*• | 1.57 x 1.57 (40 x 40) | | |
| 1.50 x 2.25 (38.1 x 57.15) | T1-1522*• | 1.57 x 2.36 (40 x 60) | | |
| 1.50 x 3.00 (38.1 x 76.2) | T1-1530*† | 1.57 x 3.15 (40 x 80) | | |
| 1.50 x 4.00 (38.1 x 101.6) | T1-1540* | 1.57 x 3.94 (40 x 100) | | |
| 2.25 x 1.50 (57.15 x 38.1) | T1-2215G• | 2.36 x 1.57(60 x 40) | | |
| 2.25 x 2.25 (57.15 x 57.15) | T1-2222*† | 2.36 x 2.36 (60 x 60) | | |
| 2.25 x 3.00 (57.15 x 76.2) | T1-2230*• | 2.36 x 3.15 (60 x 80) | | |
| 2.25 x 4.00 (57.15 x 101.6) | T1-2240*† | 2.36 x 3.94 (60 x 100) | | |
| 3.00 x 1.50 (76.2 x 38.1) | T1-3015G | 3.15 x 1.57 (80 x 40) | | |
| 3.00 x 2.25 (76.2 x 57.15) | T1-3022* | 3.15 x 2.36 (80 x 60) | | |
| 3.00 x 3.00 (76.2 x 76.2) | T1-3030*† | 3.15 x 3.15 (80 x 80) | | |
| 3.00 x 4.00 (76.2 x 101.6) | T1-3040*† | 3.15 x 3.94 (80 x 100) | | |
| 3.00 x 5.00 (76.2 x 127) | T1-3050*† | 3.15 x 4.92 (75 x 125) | | |
| 4.00 x 1.50 (101.6 x 38.1) | T1-4015G | 3.94 x 1.57 (100 x 40) | | |
| 4.00 x 2.25 (101.6 x 57.15) | T1-4022* | 3.94 x 2.36 (100 x 60) | | |
| 4.00 x 3.00 (101.6 x 76.2) | T1-4030*• | 3.94 x 3.15 (100 x 80) | | |
| 4.00 x 4.00 (101.6 x 101.6) | T1-4040*† | 3.94 x 3.94 (100 x 100) | | |
| 4.00 x 5.00 (101.6 x 127) | T1-4050*† | 3.94 x 4.92 (100 x 125) | | |
| 6.00 x 4.00 (152.4 x 101.6) | T1-6040* | 5.91 x 3.94 (150 x 100) | | |

Duct Color Notes:

- Intrinsic Blue color per ISA-RD12.6 (Instrument Society of America)
- Black color typically used to compliment the look of historically black telecommunications racks and hardware

*Color: *add suffix "G" for Light Gray

*add suffix "W" for White

•add suffix "B" for Blue

†add suffix "K" for Black

Package: add "-1" for single piece package

Note: All T1 duct comes in 6.56 feet (2m) lengths.

Wiring Duct – T1 Series Wire Fill Capacity

| Wire Fill Capacity | | | | | | |
|---|----------------------|----------|----------|----------|----------|----------|
| Nominal Duct Size (in inches) | 12 AWG | 14 AWG | 16AWG | 18 AWG | 22 AWG | |
| | Insulation Thickness | | | | | |
| | 1/32 | 3/64 | 1/32 | 1/32 | 1/32 | 1/64 |
| | OD-0.158 | OD-0.165 | OD-0.139 | OD-0.125 | OD-0.113 | OD-0.065 |
| Recommended Maximum Number of Wires per Wiring Duct (based on 50% fill capacity) | | | | | | |
| 1/2 x 5/8 | 7 | 6 | 9 | 11 | 14 | 43 |
| 1/2 x 1 | 12 | 11 | 16 | 20 | 24 | 74 |
| 1 x 1 | 22 | 21 | 29 | 36 | 44 | 134 |
| 1 x 1 1/2 | 31 | 28 | 39 | 48 | 59 | 180 |
| 1 x 2 1/4 | 45 | 40 | 57 | 71 | 85 | 261 |
| 1 x 3 | 59 | 53 | 75 | 92 | 113 | 341 |
| 1 x 4 | 72 | 66 | 93 | 115 | 141 | 426 |
| 1 1/2 x 1 1/2 | 51 | 46 | 65 | 81 | 99 | 299 |
| 1 1/2 x 2 1/4 | 77 | 70 | 98 | 121 | 148 | 449 |
| 1 1/2 x 3 | 102 | 92 | 130 | 160 | 196 | 593 |
| 1 1/2 x 4 | 125 | 113 | 159 | 197 | 241 | 729 |
| 2 1/4 x 1 1/2 | 78 | 70 | 99 | 123 | 150 | 453 |
| 2 1/4 x 2 1/4 | 114 | 103 | 146 | 180 | 221 | 667 |
| 2 1/4 x 3 | 156 | 141 | 199 | 246 | 302 | 912 |
| 2 1/4 x 4 | 194 | 176 | 247 | 306 | 375 | 1132 |
| 3 x 1 1/2 | 105 | 95 | 134 | 165 | 203 | 612 |
| 3 x 2 1/4 | 159 | 144 | 203 | 251 | 307 | 928 |
| 3 x 3 | 214 | 193 | 272 | 337 | 412 | 1246 |
| 3 x 4 | 267 | 242 | 341 | 421 | 515 | 1558 |
| 3 x 5 | 309 | 283 | 399 | 493 | 604 | 1826 |
| 4 x 1 1/2 | 132 | 120 | 169 | 208 | 255 | 771 |
| 4 x 2 1/4 | 201 | 182 | 256 | 316 | 387 | 1171 |
| 4 x 3 | 270 | 244 | 344 | 425 | 520 | 1573 |
| 4 x 4 | 336 | 305 | 429 | 531 | 650 | 1963 |
| 4 x 5 | 415 | 381 | 536 | 663 | 812 | 2455 |
| 6 x 4 | 512 | 464 | 653 | 807 | 988 | 2987 |

Overview

The base perforation of the T1 wiring duct series allows mounting on the panel with rivets R6 or R4 or on DIN rails.

The recess bosses in the base permit rapid mounting of wire retainers (CL series), inserts (ZP2), and separators (SEP series) inside the wiring duct.

Note: Duct base perforation according to DIN 43659 and DIN VDE 0660 TEIL 506.

Note: Dimensions are in inches (millimeters).

Dimensions

T1-0506

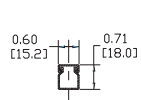

T1-1010

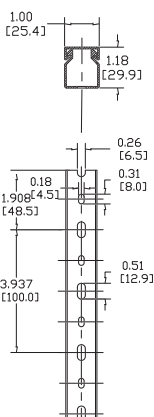

T1-15** and T1-22**

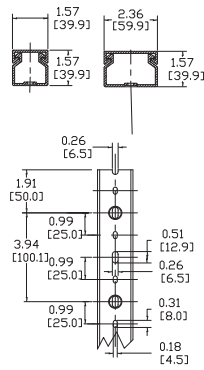

T1-3050 only

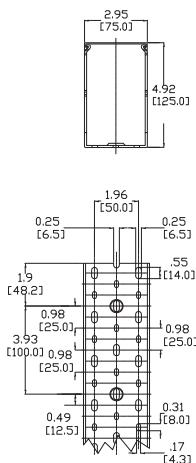

T1-30** and T1-40**

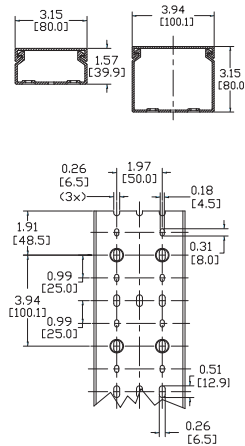

T1-6040

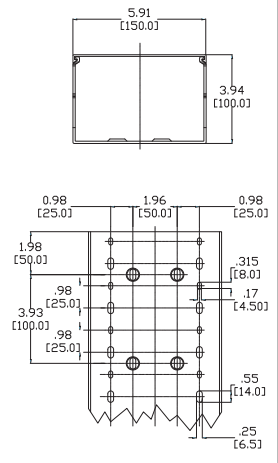

Wiring Duct – T1E Thin Finger Series

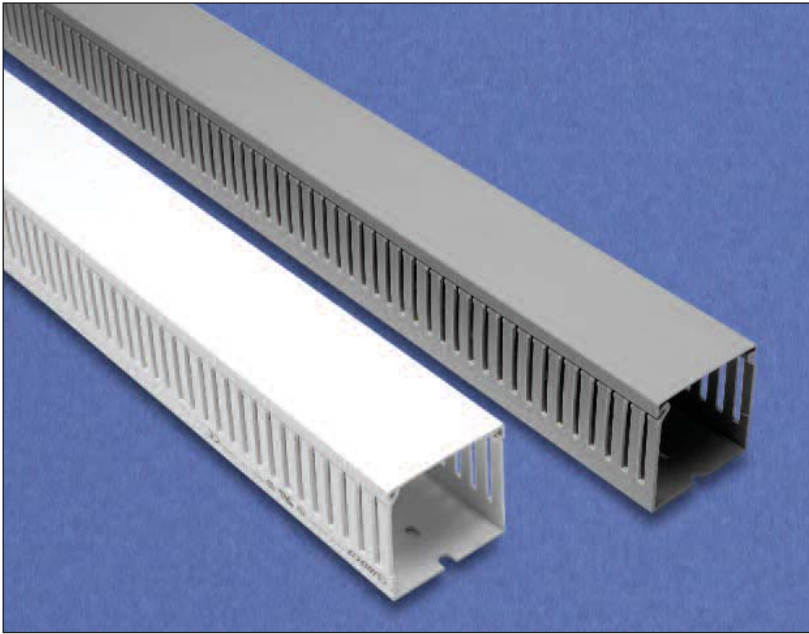

Overview

The T1E series of thin-finger wiring duct is made of rigid PVC and carries a UL 94V-0 flammability rating. All our wiring duct comes complete with cover. Replacement duct covers can be purchased separately.

Features

- Thin finger design for compact wiring configurations
- Provided with standard mounting holes
- Rounded, burr-free edges will not cut installers' hands or wiring insulation
- Non-slip cover
- Narrow thin finger design is compatible with thinner screwless terminal blocks
- Flush cover design holds 10 - 12 percent more wires than traditional designs
- Restricted slot design retains wires in slot for fast, easy wire installation or removal
- Two predetermined break lines, one for breaking off and removal of sidewall finger segments only, and another for removal of sidewall finger and base segments
- Patented recess boss for rapid mounting of components

UL file E123572



| Gray Open Slot Rigid PVC (including cover) | | | | | |
|--|------------------|-------|---------------------------------|------------------|-------|
| Catalog Number Standard Carton | Package Quantity | Price | Catalog Number Single Piece Pkg | Package Quantity | Price |
| T1E-1015G | 18 | <--> | T1E-1015G-1 | 1 | <--> |
| T1E-1022G | 24 | <--> | T1E-1022G-1 | 1 | <--> |
| T1E-1030G | 24 | <--> | T1E-1030G-1 | 1 | <--> |
| T1E-1515G | 20 | <--> | T1E-1515G-1 | 1 | <--> |
| T1E-1522G | 18 | <--> | T1E-1522G-1 | 1 | <--> |
| T1E-1530G | 16 | <--> | T1E-1530G-1 | 1 | <--> |
| T1E-1540G | 8 | <--> | T1E-1540G-1 | 1 | <--> |
| T1E-2215G | 12 | <--> | T1E-2215G-1 | 1 | <--> |
| T1E-2222G | 12 | <--> | T1E-2222G-1 | 1 | <--> |
| T1E-2230G | 12 | <--> | T1E-2230G-1 | 1 | <--> |
| T1E-2240G | 4 | <--> | T1E-2240G-1 | 1 | <--> |
| T1E-3015G | 12 | <--> | T1E-3015G-1 | 1 | <--> |
| T1E-3022G | 12 | <--> | T1E-3022G-1 | 1 | <--> |
| T1E-3030G | 12 | <--> | T1E-3030G-1 | 1 | <--> |
| T1E-3040G | 4 | <--> | T1E-3040G-1 | 1 | <--> |
| T1E-4015G | 8 | <--> | T1E-4015G-1 | 1 | <--> |
| T1E-4022G | 8 | <--> | T1E-4022G-1 | 1 | <--> |
| T1E-4030G | 8 | <--> | T1E-4030G-1 | 1 | <--> |
| T1E-4040G | 4 | <--> | T1E-4040G-1 | 1 | <--> |

| White Open Slot Rigid PVC (including cover) | | | | | |
|---|------------------|-------|---------------------------------|------------------|-------|
| Catalog Number Standard Carton | Package Quantity | Price | Catalog Number Single Piece Pkg | Package Quantity | Price |
| T1E-1015W | 18 | <--> | T1E-1015W-1 | 1 | <--> |
| T1E-1022W | 24 | <--> | T1E-1022W-1 | 1 | <--> |
| T1E-1030W | 24 | <--> | T1E-1030W-1 | 1 | <--> |
| T1E-1515W | 20 | <--> | T1E-1515W-1 | 1 | <--> |
| T1E-1522W | 18 | <--> | T1E-1522W-1 | 1 | <--> |
| T1E-1530W | 16 | <--> | T1E-1530W-1 | 1 | <--> |
| T1E-1540W | 8 | <--> | T1E-1540W-1 | 1 | <--> |
| T1E-2222W | 12 | <--> | T1E-2222W-1 | 1 | <--> |
| T1E-2230W | 12 | <--> | T1E-2230W-1 | 1 | <--> |
| T1E-2240W | 4 | <--> | T1E-2240W-1 | 1 | <--> |
| T1E-3022W | 12 | <--> | T1E-3022W-1 | 1 | <--> |
| T1E-3030W | 12 | <--> | T1E-3030W-1 | 1 | <--> |
| T1E-3040W | 4 | <--> | T1E-3040W-1 | 1 | <--> |
| T1E-4030W | 8 | <--> | T1E-4030W-1 | 1 | <--> |
| T1E-4040W | 4 | <--> | T1E-4040W-1 | 1 | <--> |

Note: All T1E duct comes in 6.56 feet (2m) lengths.

Wiring Duct – T1E Thin Finger Series

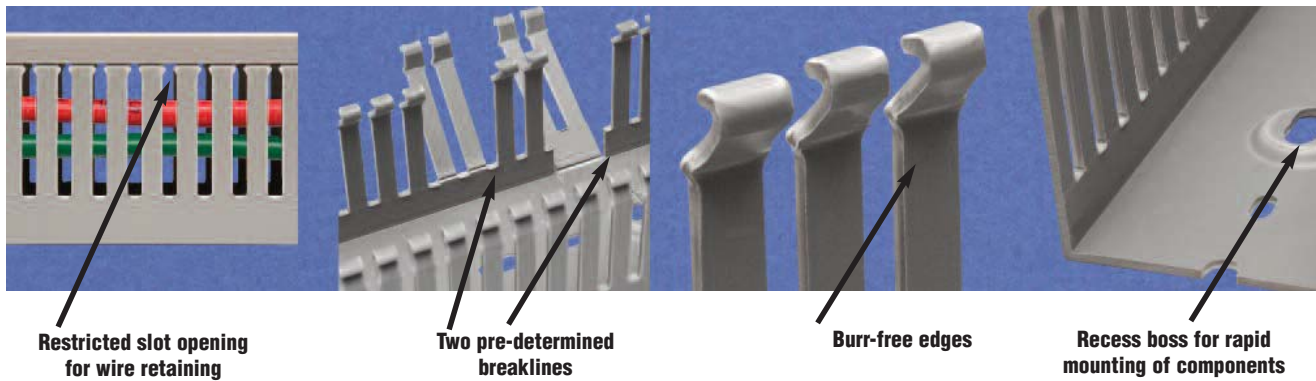

Dimensions

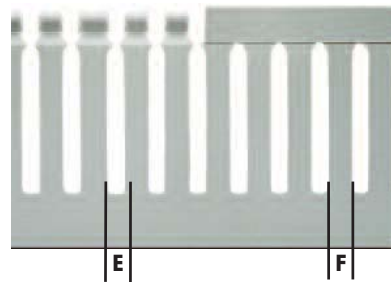
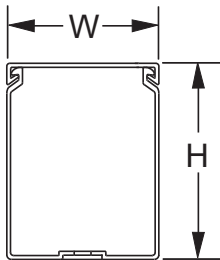

| Open Slot Rigid PVC (including cover) Dimensions | | | | |
|--|---------------------|-------------------------------|-------------------------|-------------------------|
| Nominal Size (WxH) inches (mm) | Catalog Part Number | Actual Size (WxH) inches (mm) | Dimension E inches (mm) | Dimension F inches (mm) |
| 1.00 x 1.50 (25.4 x 38.1) | T1E-1015* | 1.00 x 1.57 (25 x 40) | 0.16 (4.06) | 0.24 (6.10) |
| 1.00 x 2.25 (25.4 x 57.15) | T1E-1022* | 1.00 x 2.36 (25 x 60) | 0.16 (4.06) | 0.24 (6.10) |
| 1.00 x 3.00 (25.4 x 76.2) | T1E-1030* | 1.00 x 3.15 (25 x 80) | 0.16 (4.06) | 0.24 (6.10) |
| 1.50 x 1.50 (38.1 x 38.1) | T1E-1515* | 1.57 x 1.57 (40 x 40) | 0.16 (4.06) | 0.24 (6.10) |
| 1.50 x 2.25 (38.1 x 57.15) | T1E-1522* | 1.57 x 2.36 (40 x 60) | 0.16 (4.06) | 0.24 (6.10) |
| 1.50 x 3.00 (38.1 x 76.2) | T1E-1530* | 1.57 x 3.15 (40 x 80) | 0.16 (4.06) | 0.24 (6.10) |
| 1.50 x 4.00 (38.1 x 101.6) | T1E-1540* | 1.57 x 3.94 (40 x 100) | 0.31 (7.87) | 0.47 (11.94) |
| 2.25 x 1.50 (57.15 x 38.1) | T1E-2215G | 2.36 x 1.57(60 x 40) | 0.16 (4.06) | 0.24 (6.10) |
| 2.25 x 2.25 (57.15 x 57.15) | T1E-2222* | 2.36 x 2.36 (60 x 60) | 0.16 (4.06) | 0.24 (6.10) |
| 2.25 x 3.00 (57.15 x 76.2) | T1E-2230* | 2.36 x 3.15 (60 x 80) | 0.16 (4.06) | 0.24 (6.10) |
| 2.25 x 4.00 (57.15 x 101.6) | T1E-2240* | 2.36 x 3.94 (60 x 100) | 0.31 (7.87) | 0.47 (11.94) |
| 3.00 x 1.50 (76.2 x 38.1) | T1E-3015G | 3.15 x 1.57 (80 x 40) | 0.16 (4.06) | 0.24 (6.10) |
| 3.00 x 2.25 (76.2 x 57.15) | T1E-3022* | 3.15 x 2.36 (80 x 60) | 0.16 (4.06) | 0.24 (6.10) |
| 3.00 x 3.00 (76.2 x 76.2) | T1E-3030* | 3.15 x 3.15 (80 x 80) | 0.16 (4.06) | 0.24 (6.10) |
| 3.00 x 4.00 (76.2 x 101.6) | T1E-3040* | 3.15 x 3.94 (80 x 100) | 0.31 (7.87) | 0.47 (11.94) |
| 4.00 x 1.50 (101.6 x 38.1) | T1E-4015G | 3.94 x 1.57 (100 x 40) | 0.16 (4.06) | 0.24 (6.10) |
| 4.00 x 2.25 (101.6 x 57.15) | T1E-4022G | 3.94 x 2.36 (100 x 60) | 0.16 (4.06) | 0.24 (6.10) |
| 4.00 x 3.00 (101.6 x 76.2) | T1E-4030* | 3.94 x 3.15 (100 x 80) | 0.16 (4.06) | 0.24 (6.10) |
| 4.00 x 4.00 (101.6 x 101.6) | T1E-4040* | 3.94 x 3.94 (100 x 100) | 0.16 (4.06) | 0.24 (6.10) |

*Color: add suffix "G" for light Gray
add suffix "W" for White

Package: add "-1" for single piece package

Note: All T1E duct comes in 6.56 feet (2m) lengths.

Wiring Duct – T1E Thin Finger Series

Wire Fill Capacity

| Wire Fill Capacity | | | | | | |
|---|----------------------------------|----------|----------|----------|----------|----------|
| Nominal Duct Size (in inches) | 12 AWG | 14 AWG | 16AWG | 18 AWG | 22 AWG | |
| | Insulation Thickness (in inches) | | | | | |
| | 1/32 | 3/64 | 1/32 | 1/32 | 1/32 | 1/64 |
| | OD-0.158 | OD-0.165 | OD-0.139 | OD-0.125 | OD-0.113 | OD-0.065 |
| Recommended Maximum Number of Wires per Wiring Duct (based on 50% fill capacity) | | | | | | |
| 1 x 1 1/2 | 31 | 28 | 39 | 48 | 59 | 180 |
| 1 x 2 1/4 | 45 | 40 | 57 | 71 | 85 | 261 |
| 1 x 3 | 59 | 53 | 75 | 92 | 113 | 341 |
| 1 1/2 x 1 1/2 | 51 | 46 | 65 | 81 | 99 | 299 |
| 1 1/2 x 2 1/4 | 77 | 70 | 98 | 121 | 148 | 449 |
| 1 1/2 x 3 | 102 | 92 | 130 | 160 | 196 | 593 |
| 1 1/2 x 4 | 125 | 113 | 159 | 197 | 241 | 729 |
| 2 1/4 x 1 1/2 | 78 | 70 | 99 | 123 | 150 | 453 |
| 2 1/4 x 2 1/4 | 114 | 103 | 146 | 180 | 221 | 667 |
| 2 1/4 x 3 | 156 | 141 | 199 | 246 | 302 | 912 |
| 2 1/4 x 4 | 194 | 176 | 247 | 306 | 375 | 1132 |
| 3 x 1 1/2 | 105 | 95 | 134 | 165 | 203 | 612 |
| 3 x 2 1/4 | 159 | 144 | 203 | 251 | 307 | 928 |
| 3 x 3 | 214 | 193 | 272 | 337 | 412 | 1246 |
| 3 x 4 | 267 | 242 | 341 | 421 | 515 | 1558 |
| 4 x 1 1/2 | 132 | 120 | 169 | 208 | 255 | 771 |
| 4 x 2 1/4 | 201 | 182 | 256 | 316 | 387 | 1171 |
| 4 x 3 | 270 | 244 | 344 | 425 | 520 | 1573 |
| 4 x 4 | 336 | 305 | 429 | 531 | 650 | 1963 |

Overview

The base perforation of the T1E wiring duct series allows mounting on the panel with rivets (R6 or R4), or on DIN rail.

The recess bosses in the base permit rapid mounting of wire retainers (CL series), inserts (ZP2), and separators (SEP series) inside the wiring duct.

Note: Duct base perforation according to DIN 43659 and DIN VDE 0660 TEIL 506.

Dimensions

front section

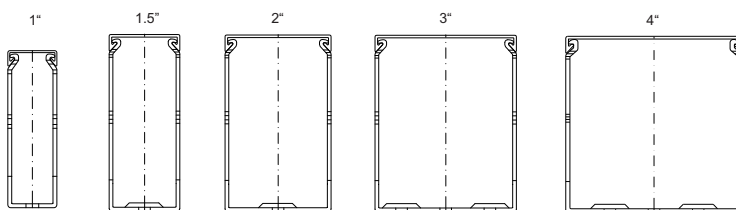

Base perforation

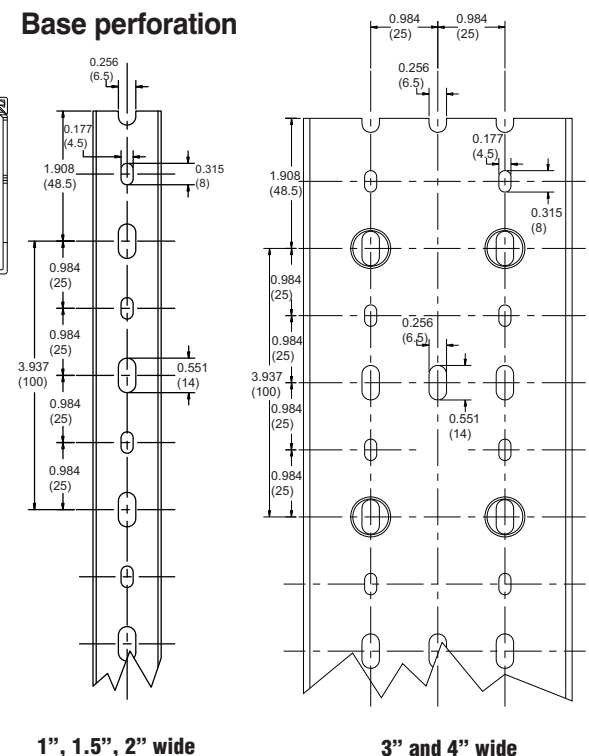

Wiring Duct – TSH Series - Solid Wall

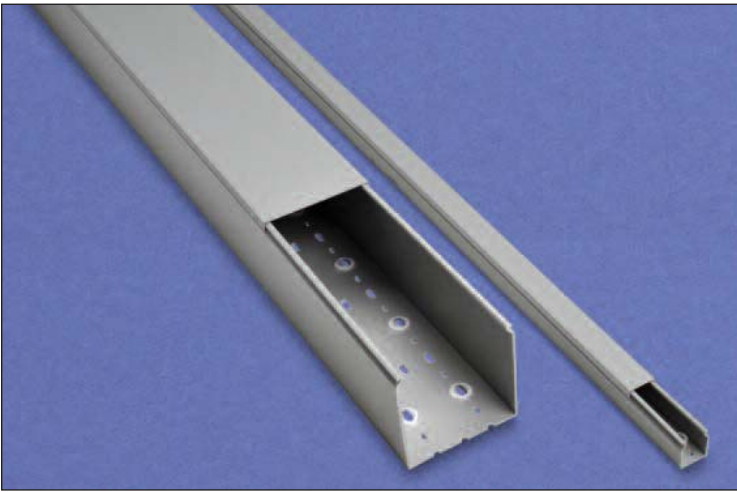

Overview

With all the standard features of the T1 Series slotted wiring duct, TSH series solid wall wiring duct is made of rigid PVC and carries a UL 94V-0 flammability rating. It is supplied complete with cover, and replacement covers can be purchased separately.

Features

- Standard mounting holes
- Non-slip cover
- Flush cover design holds 10 to 12 percent more wires than traditional designs
- Patented recessed boss for rapid mounting of components

UL file E123572



| TSH Series Gray Solid Rigid PVC (including cover) | | | | | |
|---|------------------|-------|---------------------------------|------------------|-------|
| Catalog Number Standard Carton | Package Quantity | Price | Catalog Number Single Piece Pkg | Package Quantity | Price |
| TSH-0506G | 20 | <---> | TSH-0506G-1 | 1 | <---> |
| TSH-1010G | 18 | <---> | TSH-1010G-1 | 1 | <---> |
| TSH-1015G | 18 | <---> | TSH-1015G-1 | 1 | <---> |
| TSH-1515G | 20 | <---> | TSH-1515G-1 | 1 | <---> |
| TSH-2222G | 12 | <---> | TSH-2222G-1 | 1 | <---> |
| TSH-2230G | 12 | <---> | TSH-2230G-1 | 1 | <---> |
| TSH-3030G | 12 | <---> | TSH-3030G-1 | 1 | <---> |
| TSH-4040G | 4 | <---> | TSH-4040G-1 | 1 | <---> |

Note: All TSH duct comes in 6.56 feet (2m) lengths.

| TSH Series Solid Rigid PVC Duct Dimensions | | |
|--|---------------------|-------------------------------|
| Nominal Size (WxH) inches (mm) | Catalog Part Number | Actual Size (WxH) inches (mm) |
| 0.5 x 0.625 (15 x 18) | TSH-0506G | 0.60 x 0.71 (15 x 18) |
| 1.00 x 1.00 (25.4 x 25.4) | TSH-1010G | 1.00 x 1.18 (25 x 30) |
| 1.00 x 1.50 (25.4 x 38.1) | TSH-1015G | 1.00 x 1.57 (25 x 40) |
| 1.50 x 1.50 (38.1 x 38.1) | TSH-1515G | 1.57 x 1.57 (40 x 40) |
| 2.25 x 2.25 (57.15 x 57.15) | TSH-2222G | 2.36 x 2.36 (60 x 60) |
| 2.25 x 3.00 (57.15 x 76.2) | TSH-2230G | 2.36 x 3.15 (60 x 80) |
| 3.00 x 3.00 (76.2 x 76.2) | TSH-3030G | 3.15 x 3.15 (80 x 80) |
| 4.00 x 4.00 (101.6 x 101.6) | TSH-4040G | 3.94 x 3.94 (100 x 100) |

Package: add "-1" for single piece package

Dimensions

TSH-0506

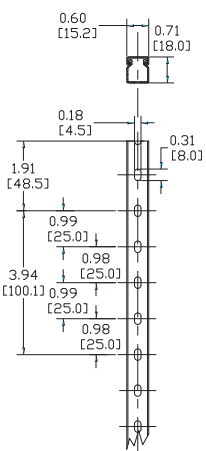

TSH-1010

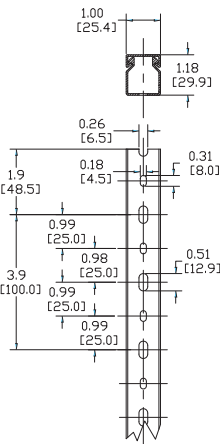

TSH-15** and TSH-22**

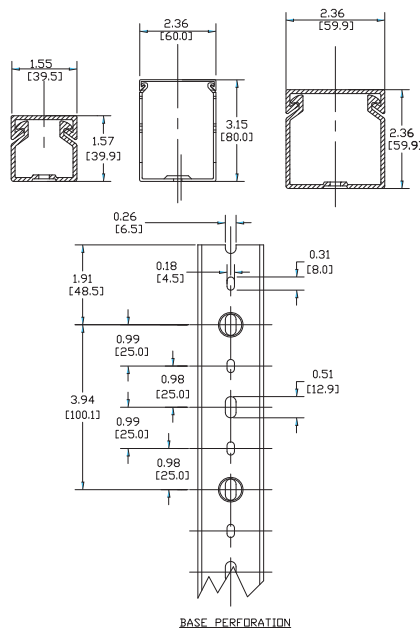

TSH-30** and TSH-40**

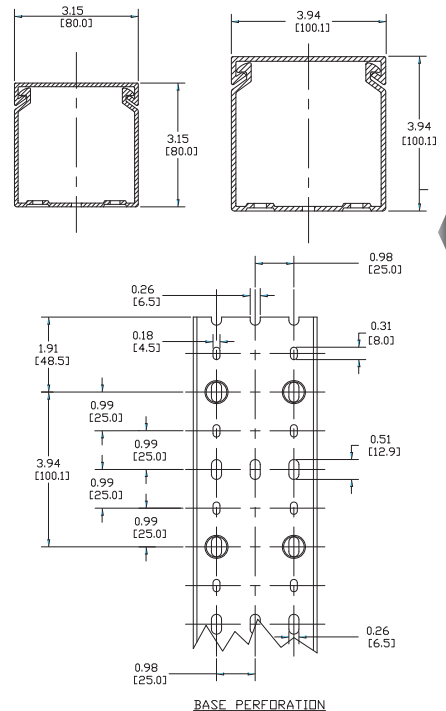

Wiring Duct Cover

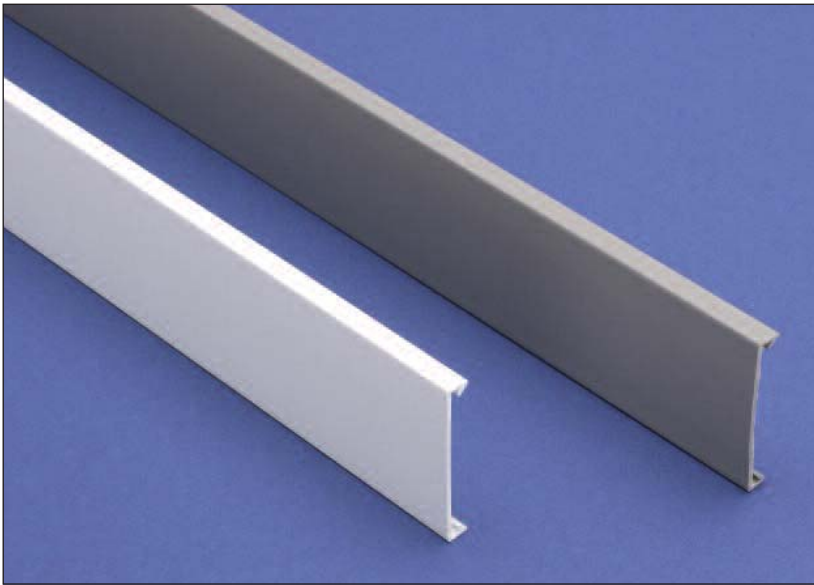

Duct Cover

Our standard wire duct products are supplied complete with covers. These replacement covers are manufactured from the same rigid self-extinguishing PVC material.

UL file E123572



| Duct Cover Specifications | | | | | |
|---------------------------|-------|---------------------------|-------|-----------------|----------------------------|
| Part Number | Price | Description | Color | Standard Carton | |
| | | | | Pcs/Pkg | Actual Total Length ft (m) |
| COV-05G | <---> | Cover for 0.5" wide duct | Gray | 25 | 164 (50) |
| COV-05G-1 | <---> | Cover for 0.5" wide duct | Gray | 1 | 6.56 (2) |
| COV-10G | <---> | Cover for 1.0" wide duct | Gray | 25 | 164 (50) |
| COV-10G-1 | <---> | Cover for 1.0" wide duct | Gray | 1 | 6.56 (2) |
| COV-10W | <---> | Cover for 1.0" wide duct | White | 25 | 164 (50) |
| COV-10W-1 | <---> | Cover for 1.0" wide duct | White | 1 | 6.56 (2) |
| COV-15G | <---> | Cover for 1.5" wide duct | Gray | 25 | 164 (50) |
| COV-15G-1 | <---> | Cover for 1.5" wide duct | Gray | 1 | 6.56 (2) |
| COV-15W | <---> | Cover for 1.5" wide duct | White | 25 | 164 (50) |
| COV-15W-1 | <---> | Cover for 1.5" wide duct | White | 1 | 6.56 (2) |
| COV-22G | <---> | Cover for 2.25" wide duct | Gray | 25 | 164 (50) |
| COV-22G-1 | <---> | Cover for 2.25" wide duct | Gray | 1 | 6.56 (2) |
| COV-22W | <---> | Cover for 2.25" wide duct | White | 25 | 164 (50) |
| COV-22W-1 | <---> | Cover for 2.25" wide duct | White | 1 | 6.56 (2) |
| COV-30G | <---> | Cover for 3.0" wide duct | Gray | 25 | 164 (50) |
| COV-30G-1 | <---> | Cover for 3.0" wide duct | Gray | 1 | 6.56 (2) |
| COV-30W | <---> | Cover for 3.0" wide duct | White | 25 | 164 (50) |
| COV-30W-1 | <---> | Cover for 3.0" wide duct | White | 1 | 6.56 (2) |
| COV-40G | <---> | Cover for 4.0" wide duct | Gray | 20 | 131.2 (40) |
| COV-40G-1 | <---> | Cover for 4.0" wide duct | Gray | 1 | 6.56 (2) |
| COV-40W | <---> | Cover for 4.0" wide duct | White | 20 | 131.2 (40) |
| COV-40W-1 | <---> | Cover for 4.0" wide duct | White | 1 | 6.56 (2) |
| COV-60G | <---> | Cover for 6.0" wide duct | Gray | 20 | 131.2 (40) |
| COV-60G-1 | <---> | Cover for 6.0" wide duct | Gray | 1 | 6.56 (2) |
| COV-60W | <---> | Cover for 6.0" wide duct | White | 20 | 131.2 (40) |
| COV-60W-1 | <---> | Cover for 6.0" wide duct | White | 1 | 6.56 (2) |

Note: Standard length of covers is 6.56 feet (2m) to fit T1, T1E and TSH duct.

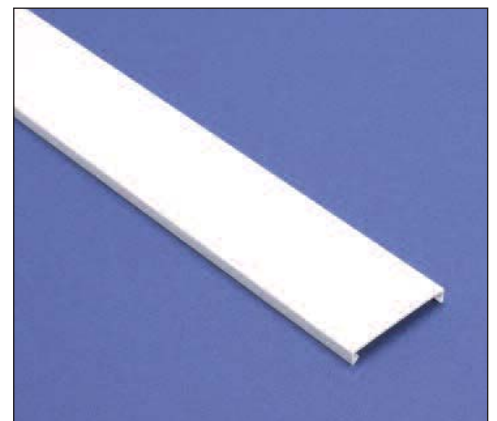
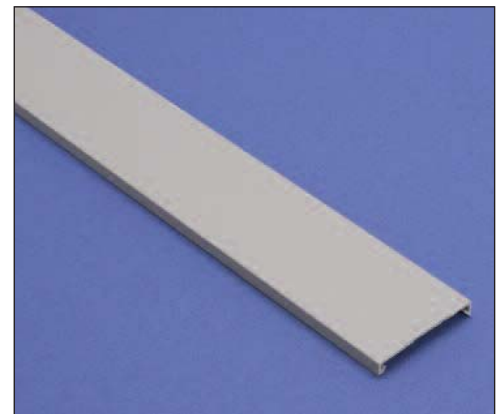

Dinosaur Flexible Wiring Duct

Overview

Dinosaur self-adhesive flexible duct is ideal for transporting wiring to cabinet doors from control panel interiors (for that part of the cable run that leans against the side of the control cabinet) and for electronic equipment. It is resilient and can be bent and twisted without breaking. Manufactured from low-smoke, halogen-free polypropylene material, it carries a UL 94V-0 flammability rating and CSA approval.



Features

- Easily add or remove individual wires from total wires within the duct
- Enclose and secure wiring or cables without requiring duct cover
- Convenient for applications requiring frequent access to wiring
- Easy addition or removal of wires after termination without special tools
- Use in extreme operating conditions (max temp. up to 176°F [80°C])
- Withstands mechanical stress when installed (i.e. earthquake, falling equipment)
- Cut to desired length using scissors or knife

Note: Make sure the surface is perfectly clean and dry before applying self-adhesive wiring duct.



UL file E123572



| White Flexible, Self-Adhesive Duct | | | | | | | |
|------------------------------------|------------------|-------|----------------------------|---------------------------------|------------------|-------|----------------------------|
| Catalog Number Standard Carton | Package Quantity | Price | Total Actual Length ft (m) | Catalog Number Single Piece Pkg | Package Quantity | Price | Total Actual Length ft (m) |
| | | | | DN20AW-1 | 1 | <---> | 1.64 (0.5) |
| DN30AW | 36 | <---> | 59.1 (18) | DN30AW-1 | 1 | <---> | 1.64 (0.5) |
| DN40AW | 20 | <---> | 32.83 (10) | DN40AW-1 | 1 | <---> | 1.64 (0.5) |

| Gray Flexible, Self-Adhesive Duct | | | | | | | |
|-----------------------------------|------------------|-------|----------------------------|---------------------------------|------------------|-------|----------------------------|
| Catalog Number Standard Carton | Package Quantity | Price | Total Actual Length ft (m) | Catalog Number Single Piece Pkg | Package Quantity | Price | Total Actual Length ft (m) |
| DN25AG | 24 | <---> | 39.4 (12) | DN25AG-1 | 1 | <---> | 1.64 (0.5) |
| DN35AG | 24 | <---> | 39.4 (12) | DN35AG-1 | 1 | <---> | 1.64 (0.5) |
| DN45AG | 14 | <---> | 23.0 (7) | DN45AG-1 | 1 | <---> | 1.64 (0.5) |

| Adhesive-Backed Tape Specifications | |
|--|--|
| Material | Double coated PET film backing, modified acrylic adhesive |
| Applicable Mounting Surfaces | Paper, cardboard, wood, glass, ceramics, metal, rubber and many plastics |
| Recommended Tape Application Temperature | 65 to 95°F (18 to 35°C) |
| Thickness | 0.2 mm |
| <i>Note: Make sure the surface is perfectly clean and dry before applying self-adhesive wiring duct.</i> | |

| Nominal Duct Size (in inches) | Wire Fill Capacity | | | | | |
|--|----------------------------------|----------|----------|----------|----------|----------|
| | 12 AWG | 14 AWG | 16 AWG | 18 AWG | 22 AWG | |
| | Insulation Thickness (in inches) | | | | | |
| | 1/32 | 3/64 | 1/32 | 1/32 | 1/32 | 1/64 |
| | OD-0.158 | OD-0.165 | OD-0.139 | OD-0.125 | OD-0.113 | OD-0.065 |
| Recommended Maximum Number of Wires per Wiring Duct (based on 50% fill capacity) | | | | | | |
| 1/2 x 1/2 | 6 | 5 | 7 | 9 | 11 | 33 |
| 3/4 x 3/4 | 13 | 12 | 6 | 20 | 25 | 75 |
| 1/2 x 3/4 | 8 | 8 | 11 | 13 | 16 | 50 |
| 1 x 1 | 23 | 21 | 29 | 36 | 44 | 133 |
| 1 x 1 3/8 | 31 | 28 | 40 | 50 | 61 | 183 |
| 1 1/2 x 1 1/2 | 51 | 46 | 65 | 81 | 99 | 299 |
| 1 3/8 x 1 3/4 | 54 | 50 | 70 | 87 | 106 | 321 |

Dinosaur Flexible Wiring Duct

Mounting Overview

The base perforation of the DN series self-adhesive flexible wiring duct also allows mounting on the panel with rivets (R6 or R4), or on DIN rail, if desired.

Note: Duct base perforation according to DIN 43659 and DIN VDE 0660 TEIL 506.

| Flexible, Self-Adhesive Duct Dimensions | | | |
|---|---------------------|-----------------|---------------------|
| Nominal Size (WxH) inches (mm) | Catalog Part Number | | Length per piece |
| | Gray | White | |
| 0.5 x 0.5 (12.7 x 12.7) | DN10AG | DN10AW ★ | 19.7" (500 mm) |
| 0.75 x 0.75 (19.05 x 19.05) | DN20AG | DN20AW ★ | 19.7" (500 mm) |
| 0.5 x 0.75 (12.7 x 19.05) | DN25AG ★ | | 19.7" (500 mm) |
| 1.0 x 1.0 (25.4 x 25.4) | DN30AG | DN30AW ★ | 19.7" (500 mm) |
| 1.0 x 1.38 (25.4 x 35.05) | DN35AG ★ | | 19.7" (500 mm) |
| 1.5 x 1.5 (38.1 x 38.1) | DN40AG | DN40AW ★ | 19.7" (500 mm) |
| 1.38 x 1.75 (35.05 x 44.45) | DN45AG ★ | | 19.7" (500 mm) |

★ Package: This product available in single-piece packaging. Add "-1" for single piece package.

Dimensions

DN10A

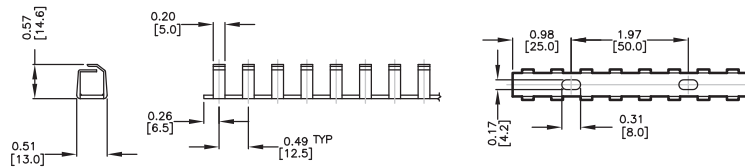

DN20A

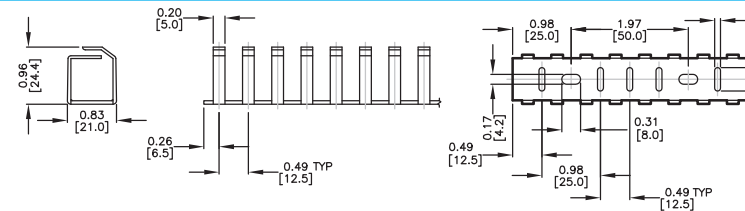

DN30A

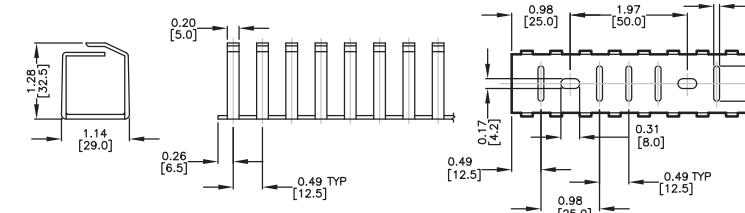

DN40A

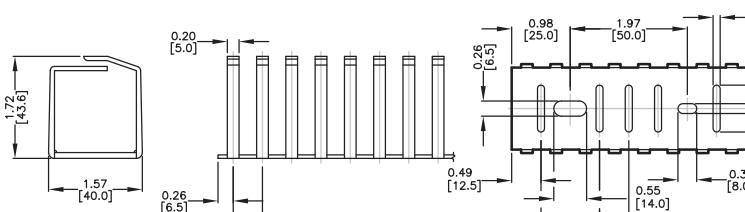

Note: Dimensions are in inches (mm).

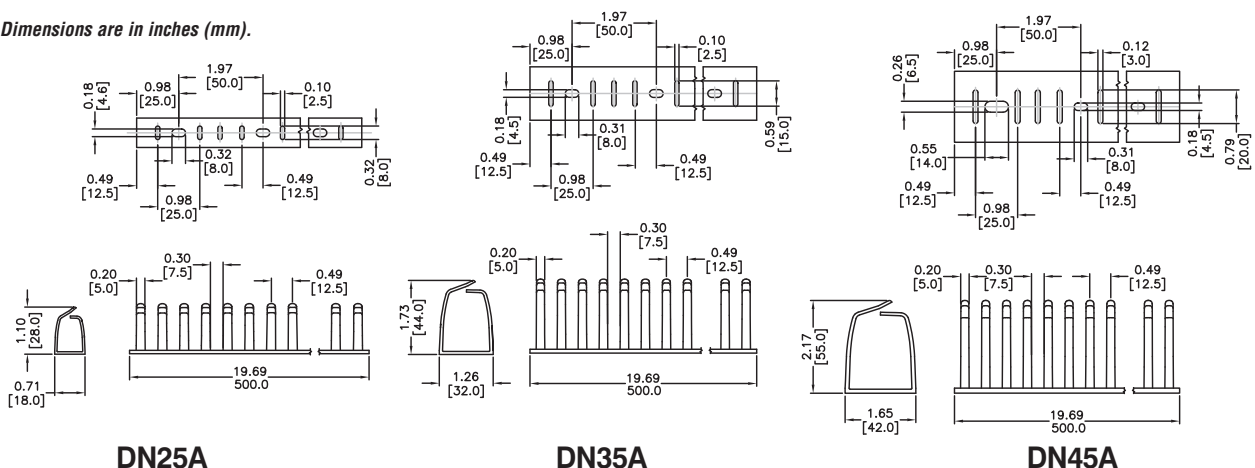

DN25A

DN35A

DN45A

Wiring Duct – Accessories

Duct Separators

Duct separators allow the physical separation of circuits within a single piece of duct. The various mounting arrangements allow alternate compartmentalization of duct and differing ratios of usable sections.

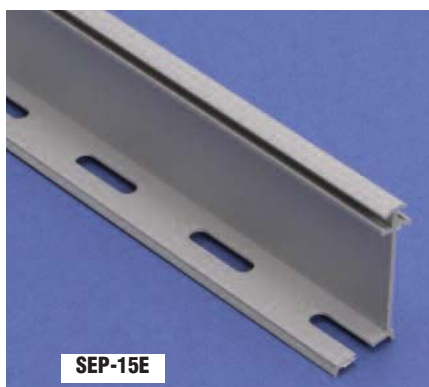
SEP-15E

Wire Retainers

For holding wires during wiring operations, these retainers are essential. They allow easy access to the interior of the wiring duct during maintenance or alterations, while assuring that wiring bundles will not fall out when the duct cover is removed. Installed with a simple rotating movement, they anchor firmly in the recess boss in the duct base.

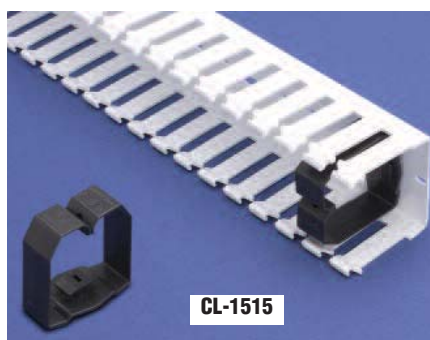
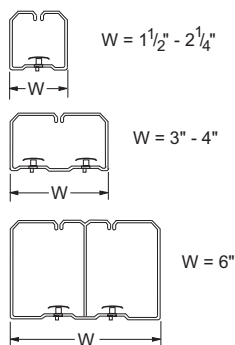
CL-1515

| Duct Separators | | | | | |
|-----------------|-------|--|-------|-----------------|----------------------------|
| Part Number | Price | Description | Color | Standard Carton | |
| | | | | Pcs/Pkg | Total Actual Length ft (m) |
| SEP-15E | <---> | Separator for 1.5" high duct, bulk pack | Gray | 32 | 209.92 (64) |
| SEP-15E-1 | <---> | Separator for 1.5" high duct | Gray | 1 | 6.56 (2) |
| SEP-22E | <---> | Separator for 2.25" high duct, bulk pack | Gray | 20 | 131.20 (40) |
| SEP-22E-1 | <---> | Separator for 2.25" high duct | Gray | 1 | 6.56 (2) |
| SEP-30E | <---> | Separator for 3.0" high duct, bulk pack | Gray | 12 | 78.72 (24) |
| SEP-30E-1 | <---> | Separator for 3.0" high duct | Gray | 1 | 6.56 (2) |

Note: Length of separators is 6.56' (2m).

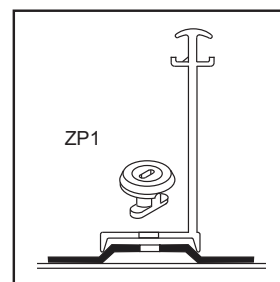

SEP-E Mounting detail
Order ZP1 mount separately

| Wire Retainers | | | | |
|----------------|-------|---|-------|---------|
| Part Number | Price | Description | Color | Pcs/Pkg |
| CL-1515 | <---> | Wire retainer fastener for 1.5" x 1.5" duct | Gray | 40 |
| CL-1522 | <---> | Wire retainer fastener for 1.5" x 2.25" duct | Gray | 40 |
| CL-1530 | <---> | Wire retainer fastener for 1.5" x 3.0" duct | Gray | 20 |
| CL-2215 | <---> | Wire retainer fastener for 2.25" x 1.5" duct | Gray | 40 |
| CL-2222 | <---> | Wire retainer fastener for 2.25" x 2.25" duct | Gray | 20 |
| CL-2230 | <---> | Wire retainer fastener for 2.25" x 3.0" duct | Gray | 20 |
| CL-2240 | <---> | Wire retainer fastener for 2.25" x 4.0" duct | Gray | 20 |
| CL-3022 | <---> | Wire retainer fastener for 3.0" x 2.25" duct | Gray | 10 |
| CL-3030 | <---> | Wire retainer fastener for 3.0" x 3.0" duct | Gray | 10 |
| CL-3040 | <---> | Wire retainer fastener for 3.0" x 4.0" duct | Gray | 10 |
| CL-4015 | <---> | Wire retainer fastener for 4.0" x 1.5" duct | Gray | 10 |
| CL-4022 | <---> | Wire retainer fastener for 4.0" x 2.25" duct | Gray | 10 |
| CL-4030 | <---> | Wire retainer fastener for 4.0" x 3.0" duct | Gray | 10 |
| CL-4040 | <---> | Wire retainer fastener for 4.0" x 4.0" duct | Gray | 5 |
| CL-6040 | <---> | Wire retainer fastener for 6.0" x 4.0" duct | Gray | 5 |

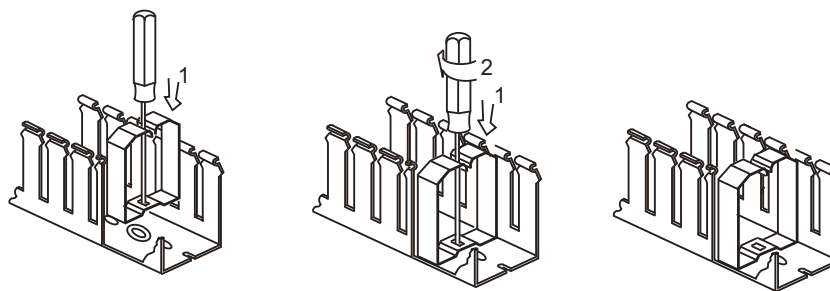

Wiring Duct – Accessories

Duct Marking Tags

| Part Number | Price | Description | Pcs/Pkg |
|-------------|-------|--|---------|
| DM1 | <---> | Single-width white cardboard identification label for wiring duct. Supplied with black plastic mounting clip and transparent plastic cover slide | 50 |

Note: DM1 marking tags can only be used with T1 series wire duct.

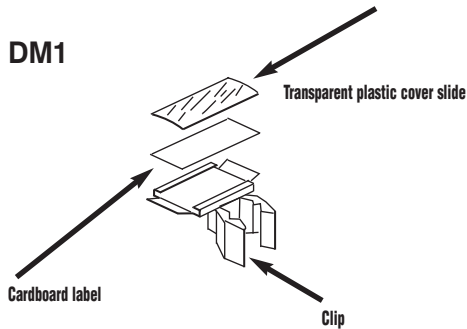

Identification Tags

Allowing easy identification of control gear and switchgear, these tags are mounted by snapping the clip onto the sidewall finger segments of the duct. No gluing - no drilling! After installation, they need not be removed during maintenance or any work which involves the removal of the covers.

Note: Take care that clip is installed above the wires coming out to the sidewall slots.

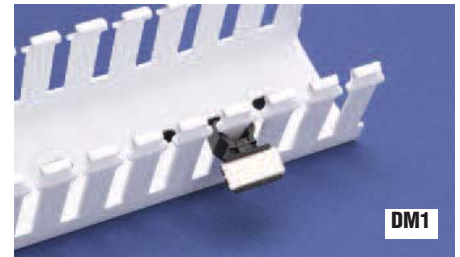

Mounting Devices

| Part Number | Price | Description | Pcs/Pkg |
|-------------|-------|--|---------|
| ZP1 | <---> | Round, white polyamide 'button' used to mount components and separators inside duct. | 100 |
| ZP2 | <---> | Square white polyamide cable tie mount used to tighten a wire bundle inside duct. | 50 |

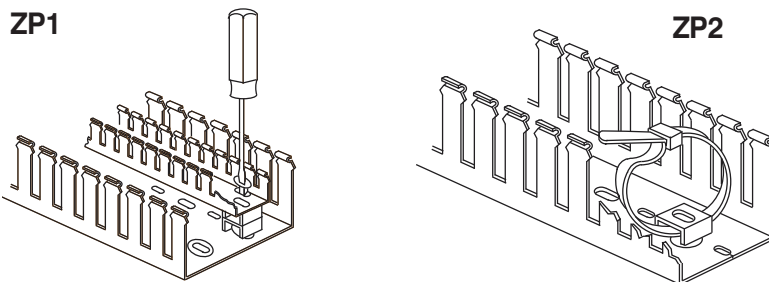

Mounting Inserts

We carry mounts in two styles: ZP1 for mounting components and separators inside duct, or for mounting small sizes of duct inside larger sizes (for separation of circuits with different functions); and ZP2, which is used with a cable tie to secure a wire bundle inside the duct.



Wiring Duct Rivets and Rivet Tools

| Part Number | Price | Description | Pcs/Pkg |
|-------------|-------|---|---------|
| R4 | <---> | Blue polyamide rivet used to install all types of wiring duct with standard 5/32" (4 mm) mounting holes. | 250 |
| B4 | <---> | Red polyamide rivet tool used to install R4 rivets. | 1 |
| R6 | <---> | Natural polyamide rivet used to install all types of wiring duct with standard 7/32" (5.5 mm) mounting holes. | 250 |
| B6 | <---> | Yellow polyamide rivet tool used to install R6 rivets. | 1 |

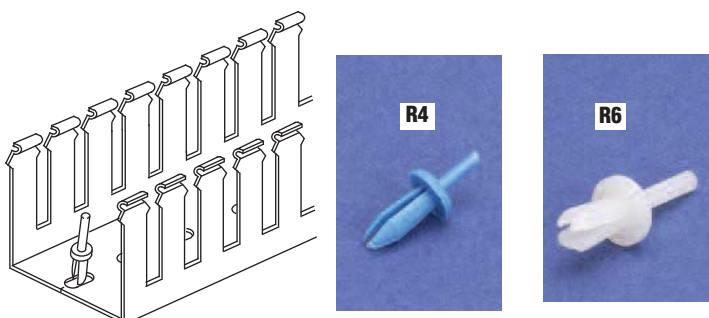

Rivets and Rivet Tools

Wiring duct rivets install quickly and easily with the companion rivet tool, offering good temperature resistance and excellent mechanical properties. They can be used to install all types of wiring duct with standard mounting holes.

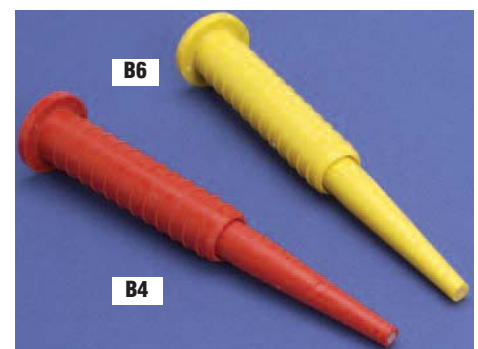

Wiring Duct – Accessories

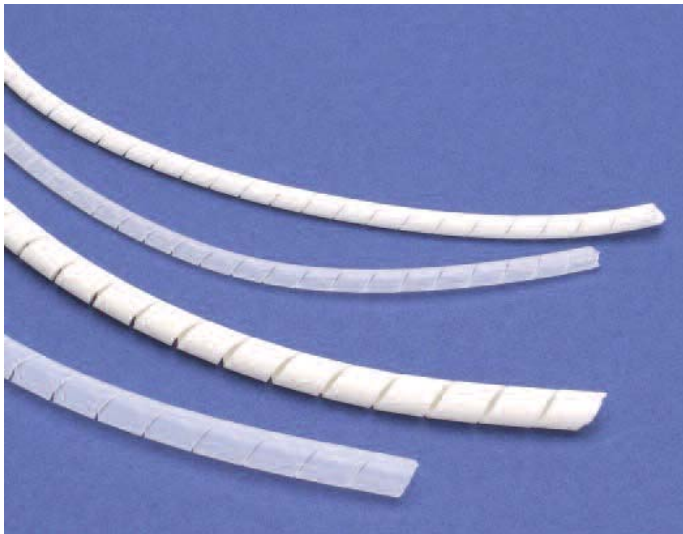

Spiral Wrap

For neatly grouping wire bundles simply and economically, spiral wrap has no equal. Strong, yet easy to install, it protects the wire bundle, keeping it flexible though tightly contained. It is easily removed and reusable for temporary wiring.

| Spiral Wrap | | | | |
|-------------|-------|---|---------|--------------|
| Part Number | Price | Description | Color | Length |
| P-1 | <--> | 0.125" nominal o.d. Polyethylene spiral wrap used for wire bundles from 1/16 to 1/2 inch diameter. | Natural | 160 ft./pack |
| PA1 | <--> | 0.125" nominal o.d. self-extinguishing Polyethylene spiral wrap used for wire bundles from 1/16 to 1/2 inch diameter. | White | 160 ft./pack |
| P-2 | <--> | 0.25" nominal o.d. Polyethylene spiral wrap used for wire bundles from 1/4 to 2 inch diameter. | Natural | 80 ft./pack |
| PA2 | <--> | 0.25" nominal o.d. self-extinguishing Polyethylene spiral wrap used for wire bundles from 1/4 to 2 inch diameter. | White | 80 ft./pack |
| P-3 | <--> | 0.375" nominal o.d. Polyethylene spiral wrap used for wire bundles from 3/8 to 3 inch diameter. | Natural | 80 ft./pack |
| PA3 | <--> | 0.375" nominal o.d. self-extinguishing Polyethylene spiral wrap used for wire bundles from 3/8 to 3 inch diameter. | White | 80 ft./pack |
| P-4 | <--> | 0.5" nominal o.d. Polyethylene spiral wrap used for wire bundles from 1/2 to 4 inch diameter. | Natural | 65 ft./pack |
| PA4 | <--> | 0.5" nominal o.d. self-extinguishing Polyethylene spiral wrap used for wire bundles from 1/2 to 4 inch diameter. | White | 65 ft./pack |

Dimensions

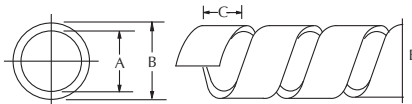

| Catalog Number | | Dimensions in Inches | | | Wire Bundle Size in Inches | Feet per Carton |
|----------------|------------------------------|----------------------|-----|-----|----------------------------|-----------------|
| Polyethylene | Flame-Retardant Polyethylene | A | B | C | | |
| P-1 | PA1 | .06 | .12 | .20 | 1/16 to 1/2 | 160 |
| P-2 | PA2 | .16 | .24 | .31 | 1/4 to 2 | 80 |
| P-3 | PA3 | .31 | .39 | .47 | 3/8 to 3 | 80 |
| P-4 | PA4 | .35 | .47 | .47 | 1/2 to 4 | 65 |

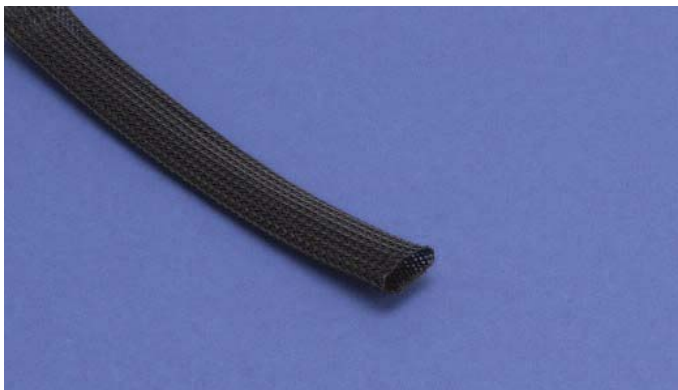

Braided Sleeving

This lightweight, expandable, self-extinguishing polyester sleeving has an open weave to allow maximum diameter expansion. It is super-flexible and easy to install, gripping objects of various shapes and sizes reliably. Abrasion-resistant, it provides extra protection against chemicals and flame.

| Braided Expandable Sleeving Material Specifications | |
|---|-----------------------------------|
| Operating Temp | -50°C to +150°C (-58°F to +302°F) |
| Physical Properties | Self-extinguishing for UL 94V-2 |
| Maximum Elongation | 42% |
| Diameter Expansion | 100% |
| Other | Halogen-free |

| Expandable Sleeving | | | | |
|---------------------|-------|---|-------|--------------|
| Part Number | Price | Description | Color | Length |
| TY-5 | <--> | Braided expandable polyester sleeving, 0.197" (5mm) nominal i.d., 0.157" (4mm) to 0.472" (12mm) nominal range | Black | 325 ft./pack |
| TY-10 | <--> | Braided expandable polyester sleeving, 0.375" (10mm) nominal i.d., 0.315" (8mm) to 0.866" (22mm) nominal range | Black | 325 ft./pack |
| TY-20 | <--> | Braided expandable polyester sleeving, 0.750" (20mm) nominal i.d., 0.630" (16mm) to 1.378" (35mm) nominal range | Black | 164 ft./pack |
| TY-30 | <--> | Braided expandable polyester sleeving, 1.125" (30mm) nominal i.d., 0.984" (25mm) to 1.890" (48mm) nominal range | Black | 164 ft./pack |
| TY-50 | <--> | Braided expandable polyester sleeving, 2.0" (50mm) nominal i.d., 1.575" (40mm) to 2.825" (72mm) nominal range | Black | 164 ft./pack |

Wiring Duct – Material Specifications

| Material Specifications | | | | | | | | |
|-------------------------------------|---------------|-------------------|--------------------|------------------|-----------------------|-----------------------|---------------------|------------------------------|
| Materials | Test Standard | Unit of Measure | Rigid PVC | Polypropylene | PVC Molded Components | Polyamide 6 | Polyethylene | Flame Retardant Polyethylene |
| Technical Characteristics | | | | | | | | |
| Chemical/Physical Properties | | | | | | | | |
| Specific Gravity | ASTM D792 | g/cm ³ | 1.55 | 1.01 | 1.32 | 1.14 | 0.92 | 0.97 |
| H ₂ O 73.4°F Absorption | ISO 62 | % | <0.1 | 0.02 | <0.1 | 2.5 | <0.1 | <0.1 |
| Formaldehyde | – | ppm | absent | absent | absent | absent | absent | absent |
| Cadmium | – | ppm | absent | absent | absent | absent | absent | absent |
| Mechanical Properties | | | | | | | | |
| Tensile Stress at Break | ASTM D638 | MPa | 39 | 28 | 30 | 45 | 17 | 15 |
| Traction Strength | ASTM D638 | MPa | 44 | 27 | 27 | 55 | 9.5 | 9 |
| Elongation at Break | ASTM D638 | % | 130 | 200 | 97 | 250 | 400 | 600 |
| Modulus of Elasticity at Traction | ASTM D638 | MPa | 4400 | n/a | – | 950 | – | 240 |
| Modulus of Elasticity at Flexion | ASTM D790 | MPa | 3200 | 2100 | – | 1100 | 210 | 130 |
| Thermal Properties | | | | | | | | |
| Temperature VICAT | ASTM D1525 | °C | 84 | 95 | 70 | 198 | 89 | – |
| HDT | ASTM D648 | °C | 72 | 60 | 60 | 185 | – | – |
| Coefficient of Expansion | ASTM D696 | K ⁻¹ | 6 10 ⁻⁵ | 10 ⁻⁵ | 8 10 ⁻⁵ | 8-10 10 ⁻⁵ | 22 10 ⁻⁵ | 10 ⁻⁵ |
| Specific Heat | ASTM C351 | kJ/kgK | 0.94 | n/a | 1.24 | 1.7 | – | – |
| Thermal Conductivity | ASTM C177 | W/mK | 0.14 | 0.21 | 0.14 | 0.29 | 0.32 | 0.32 |
| Electrical Properties | | | | | | | | |
| Dielectric Constant | ASTM D150 | – | 3.2 - 4.0 | 2.5 | 3.2 | 5.0 | 2.4 | 2.3 |
| Dielectric Strength | IEC 243 | kV/mm | 70 | 25 | 60 | 35 | 90 | 90 |
| Surface Resistance | IEC 93 | Ω | 10 ¹³ | 10 ¹³ | 10 ¹³ | 5 10 ¹¹ | 10 ¹³ | 10 ¹³ |
| Self-Extinguishing | | | | | | | | |
| Self-Extinguishing UL 94 1.6 mm | UL 94 | – | V-0 | V-0 | V-0 | V-2 | HB | V-2 |
| Self-Extinguishing UL 94 3.2 mm | UL 94 | – | V-0 | V-0 | V-0 | V-2 | HB | V-2 |
| Hot Wire Test (2 mm) | IEC 695-2-1 | °C | 960 | 960 | 960 | 650 | 650 | 850 |
| Oxygen Number | ASTM D2863 | % | 43 | 30 | 34 | 25 | – | 25 |

I-Flex Flexible Liquid-Tight PVC Tubing



Overview

This leak-proof, flexible tubing provides electrical wire protection during routing applications. I-Flex can be used in extremely tight quarters, thanks to its flexibility. It is just right for basic applications where fast installation and maximum flexibility are a must, and is the solution in areas where movement, vibration, or flexing can be a problem. This tubing provides excellent tensile strength and the smooth interior wall protects wiring. All models are available in light gray or black.

Applications

- Where oil resistance is required, or where water corrosion or ultraviolet light is a problem
- Protection of fiber optic cable
- Installing instrumentation or control cable
- Wire harness protection
- Packaging equipment
- Marine applications

Features

- UL recognized File E311916
- CE certified
- IP 65-rated for watertight applications
- Operating temperature: -4°F to 140°F (-20° to 60°C)



| IBOCO Gray I-Flex Tubing | | | | | | | | Use With This Straight Connector | | Use With This 90° Connector | |
|--------------------------|-------|---------------------|--------------------|--------------------|---------------------------|------------------|---------------------------|----------------------------------|-------|-----------------------------|-------|
| Part Number | Price | Trade Size in. (mm) | Actual ID in. (mm) | Actual OD in. (mm) | Min. Bend Radius in. (mm) | Weight lbs/98 ft | Coil Length feet (meters) | Part Number | Price | Part Number | Price |
| GUA-12G | <--> | 3/8 (12) | 0.47 (11.94) | 0.65 (16.51) | 0.49 (12.45) | 6.1 | 98' (30 m) | RA-12G | <--> | CUR-12G | <--> |
| GUA-16G | <--> | 1/2 (16) | 0.63 (16.00) | 0.81 (20.57) | 0.63 (16.00) | 7.1 | 98' (30 m) | RA-16G | <--> | CUR-16G | <--> |
| GUA-20G | <--> | 3/4 (21) | 0.79 (20.07) | 0.97 (24.64) | 0.83 (21.08) | 9.6 | 98' (30 m) | RA-20G | <--> | CUR-20G | <--> |
| GUA-25G | <--> | 1 (27) | 0.98 (24.89) | 1.2 (30.48) | 1.10 (27.94) | 13.4 | 98' (30 m) | RA-25G | <--> | CUR-25G | <--> |
| GUA-32G | <--> | 1.25 (35) | 1.25 (31.75) | 1.5 (38.10) | 1.40 (35.56) | 17.7 | 98' (30 m) | RA-32G | <--> | CUR-32G | <--> |
| GUA-40G | <--> | 1.50 (41) | 1.57 (39.88) | 1.83 (46.48) | 1.59 (40.39) | 23.6 | 98' (30 m) | RA-40G | <--> | not available | |
| GUA-50G | <--> | 2 (53) | 1.97 (50.04) | 2.24 (56.90) | 2.04 (51.82) | 31.2 | 98' (30 m) | RA-50G | <--> | not available | |

| IBOCO Black I-Flex Tubing | | | | | | | | Use With This Straight Connector | | Use With This 90° Connector | |
|---------------------------|-------|-------------------|--------------------|--------------------|---------------------------|------------------|---------------------------|----------------------------------|-------|-----------------------------|-------|
| Part Number | Price | Trade Size in(mm) | Actual ID in. (mm) | Actual OD in. (mm) | Min. Bend Radius in. (mm) | Weight lbs/98 ft | Coil Length feet (meters) | Part Number | Price | Part Number | Price |
| GUA-12K | <--> | 3/8 (12) | 0.47 (11.94) | 0.65 (16.51) | 0.49 (12.45) | 6.1 | 98' (30 m) | RA-12K | <--> | CUR-12K | <--> |
| GUA-16K | <--> | 1/2 (16) | 0.63 (16.00) | 0.81 (20.57) | 0.63 (16.00) | 7.1 | 98' (30 m) | RA-16K | <--> | CUR-16K | <--> |
| GUA-20K | <--> | 3/4 (21) | 0.79 (20.07) | 0.97 (24.64) | 0.83 (21.08) | 9.6 | 98' (30 m) | RA-20K | <--> | CUR-20K | <--> |
| GUA-25K | <--> | 1 (27) | 0.98 (24.89) | 1.2 (30.48) | 1.10 (27.94) | 13.4 | 98' (30 m) | RA-25K | <--> | CUR-25K | <--> |
| GUA-32K | <--> | 1.25 (35) | 1.25 (31.75) | 1.5 (38.10) | 1.40 (35.56) | 17.7 | 98' (30 m) | RA-32K | <--> | CUR-32K | <--> |
| GUA-40K | <--> | 1.50 (41) | 1.57 (39.88) | 1.83 (46.48) | 1.59 (40.39) | 23.6 | 98' (30 m) | RA-40K | <--> | not available | |
| GUA-50K | <--> | 2 (53) | 1.97 (50.04) | 2.24 (56.90) | 2.04 (51.82) | 31.2 | 98' (30 m) | RA-50K | <--> | not available | |

Straight and Right-Angle Connectors for I-Flex Flexible Liquid-Tight PVC Tubing



Overview

These straight and right angle (90°) liquid-tight non-metallic connectors are made to fit our line of flexible liquid-tight PVC tubing. Used together, they ensure leak-proof integrity on motors, processing equipment, pumps, etc. Available in light gray or black.

Choose these liquid-tight connectors for:

- A liquid-tight environmental seal
- Quick re-entry for cable repair or rerouting

Features

- Seal gaskets included with each pack of connectors
- Material: Polypropylene
- Suitable for indoor and outdoor applications
- Corrosion resistant
- Resists solvents, grease, oil, alcohol, gasoline, and saltwater
- Adjustable collar
- Constructed of fire-resistant Polypropylene
- Operating temperature: -4°F to 140°F (-20° to 60°C)
- UL recognized File E311916
- CE certified
- IP 65-rated for watertight applications



| IBOCO Gray I-Flex Tubing Straight Connectors | | | | | |
|--|-------|---------------------|--------------------|--------------------|------------------|
| Part Number | Price | Trade Size in. (mm) | Actual ID in. (mm) | Actual OD in. (mm) | Package Quantity |
| RA-12G | <---> | 3/8 (12) | 0.47 (11.94) | 3/8" int (16.5) | 20 |
| RA-16G | <---> | 1/2 (16) | 0.63 (16.00) | 1/2" int (20.7) | 20 |
| RA-20G | <---> | 3/4 (21) | 0.79 (20.07) | 3/4" int (26) | 20 |
| RA-25G | <---> | 1 (27) | 0.98 (24.89) | 1" int (32.7) | 10 |
| RA-32G | <---> | 1.25 (35) | 1.25 (31.75) | 1.25" int (41.9) | 10 |
| RA-40G | <---> | 1.50 (41) | 1.57 (39.88) | 1 1/2" int (47.8) | 5 |
| RA-50G | <---> | 2 (53) | 1.97 (50.04) | 2" int (59.6) | 5 |

| IBOCO Gray I-Flex Tubing 90° Connectors | | | | | |
|---|-------|---------------------|--------------------|--------------------|------------------|
| Part Number | Price | Trade Size in. (mm) | Actual ID in. (mm) | Actual OD in. (mm) | Package Quantity |
| CUR-12G | <---> | 3/8 (12) | 0.47 (11.94) | 3/8" int (16.5) | 25 |
| CUR-16G | <---> | 1/2 (16) | 0.63 (16.00) | 1/2" int (20.7) | 25 |
| CUR-20G | <---> | 3/4 (21) | 0.79 (20.07) | 3/4" int (26) | 15 |
| CUR-25G | <---> | 1 (27) | 0.98 (24.89) | 1" int (32.7) | 5 |
| CUR-32G | <---> | 1.25 (35) | 1.25 (31.75) | 1.25" int (41.9) | 5 |

| IBOCO Black I-Flex Tubing Straight Connectors | | | | | |
|---|-------|---------------------|--------------------|--------------------|------------------|
| Part Number | Price | Trade Size in. (mm) | Actual ID in. (mm) | Actual OD in. (mm) | Package Quantity |
| RA-12K | <---> | 3/8 (12) | 0.47 (11.94) | 3/8" int (16.5) | 20 |
| RA-16K | <---> | 1/2 (16) | 0.63 (16.00) | 1/2" int (20.7) | 20 |
| RA-20K | <---> | 3/4 (21) | 0.79 (20.07) | 3/4" int (26) | 20 |
| RA-25K | <---> | 1 (27) | 0.98 (24.89) | 1" int (32.7) | 10 |
| RA-32K | <---> | 1.25 (35) | 1.25 (31.75) | 1.25" int (41.9) | 10 |
| RA-40K | <---> | 1.50 (41) | 1.57 (39.88) | 1 1/2" int (47.8) | 5 |
| RA-50K | <---> | 2 (53) | 1.97 (50.04) | 2" int (59.6) | 5 |

| IBOCO Black I-Flex Tubing 90° Connectors | | | | | |
|--|-------|---------------------|--------------------|--------------------|------------------|
| Part Number | Price | Trade Size in. (mm) | Actual ID in. (mm) | Actual OD in. (mm) | Package Quantity |
| CUR-12K | <---> | 3/8 (12) | 0.47 (11.94) | 3/8" int (16.5) | 25 |
| CUR-16K | <---> | 1/2 (16) | 0.63 (16.00) | 1/2" int (20.7) | 25 |
| CUR-20K | <---> | 3/4 (21) | 0.79 (20.07) | 3/4" int (26) | 15 |
| CUR-25K | <---> | 1 (27) | 0.98 (24.89) | 1" int (32.7) | 5 |
| CUR-32K | <---> | 1.25 (35) | 1.25 (31.75) | 1.25" int (41.9) | 5 |

Cable Ties

Cable ties are a simple, convenient and economical wire management solution. We offer several styles and sizes, as well as tie mounts and installation tools. Our selection, from basic nylon 6.6 ties to UV-rated, and from releasable to ID tag or lashing tie styles, will cover most of your cable tie requirements.



BM-B1025



BM-N8190



Standard Cable Ties

Resistant to oils, grease, solvents and petroleum products

- Material: 6.6 Nylon MIL-M-20693
- Operating Temperature: -40° to 185°F (-40° to 85°C).
- MIL-S-23190
- Self-extinguishing UL 94V-2

- UL Recognized, File E223175 (No UL for Releasable and Marker Tag type)
- All nylon 6.6 ties are CE and RoHS compliant

Cable Ties, Natural Nylon 6.6

| Part Number | Package Quantity | Price | Part Number | Package Quantity | Price | Min. Loop Tensile Strength N (lbs) | Length mm (in.) | Width mm (in.) | Max. Bundle Diameter mm (in.) | Installation Tools | Accessories |
|-----------------|------------------|-------|-----------------------------------|------------------|-------|------------------------------------|-----------------|----------------|-------------------------------|--------------------|--|
| BM-B1025 | 100 | <--> | BM-B1025M | 1000 | <--> | 80 (18) | 100 (3.94) | 2.5 (0.10) | 18 (0.71) | BM-1100 | BM-B0901, BM-N0901 BM-B0902, BM-N0902 BM-B0903, BM-N0903 |
| BM-B1625 | 100 | <--> | BM-B1625M | 1000 | <--> | 80 (18) | 160 (6.30) | 2.5 (0.10) | 40 (1.57) | | |
| BM-B2025 | 100 | <--> | BM-B2025M | 1000 | <--> | 80 (18) | 200 (7.90) | 2.5 (0.10) | 50 (1.97) | | |
| BM-B1436 | 100 | <--> | BM-B1436M | 1000 | <--> | 180 (40) | 140 (5.51) | 3.6 (0.14) | 33 (1.30) | | |
| BM-B2036 | 100 | <--> | BM-B2036M | 1000 | <--> | 180 (40) | 200 (7.87) | 3.6 (0.14) | 50 (1.97) | | |
| BM-B2936 | 100 | <--> | BM-B2936M | 1000 | <--> | 180 (40) | 290 (11.42) | 3.6 (0.14) | 76 (2.99) | | |
| BM-B3736 | 100 | <--> | Not available in bulk pack | | | 180 (40) | 370 (14.57) | 3.6 (0.14) | 102 (4.02) | | |
| BM-B1648 | 100 | <--> | BM-B1648M | 1000 | <--> | 220 (50) | 160 (6.30) | 4.8 (0.19) | 38 (1.50) | | |
| BM-B1948 | 100 | <--> | BM-B1948M | 1000 | <--> | 220 (50) | 190 (7.48) | 4.8 (0.19) | 43 (1.69) | | |
| BM-B3048 | 100 | <--> | BM-B3048M | 1000 | <--> | 220 (50) | 300 (11.81) | 4.8 (0.19) | 76 (2.99) | | |
| BM-B3748 | 100 | <--> | Not available in bulk pack | | | 220 (50) | 370 (14.57) | 4.8 (0.19) | 102 (4.02) | | |
| BM-B3776 | 100 | <--> | Not available in bulk pack | | | 540 (120) | 370 (14.57) | 7.6 (0.30) | 102 (4.02) | | |
| BM-B7190 | 100 | <--> | Not available in bulk pack | | | 790 (175) | 710 (27.95) | 9 (0.35) | 190 (7.48) | | |
| BM-B8190 | 100 | <--> | Not available in bulk pack | | | 790 (175) | 810 (31.90) | 9 (0.35) | 239 (9.41) | | |

Cable Ties, Black Nylon 6.6

| Part Number | Package Quantity | Price | Part Number | Package Quantity | Price | Min. Loop Tensile Strength N (lbs) | Length mm (in.) | Width mm (in.) | Max. Bundle Diameter mm (in.) | Installation Tools | Accessories |
|-----------------|------------------|-------|-----------------------------------|------------------|-------|------------------------------------|-----------------|----------------|-------------------------------|--------------------|--|
| BM-N1025 | 100 | <--> | BM-N1025M | 1000 | <--> | 80 (18) | 100 (3.94) | 2.5 (0.10) | 18 (0.71) | BM-1100 | BM-B0901, BM-N0901 BM-B0902, BM-N0902 BM-B0903, BM-N0903 |
| BM-N1625 | 100 | <--> | BM-N1625M | 1000 | <--> | 80 (18) | 160 (6.30) | 2.5 (0.10) | 40 (1.57) | | |
| BM-N2025 | 100 | <--> | Not available in bulk pack | | | 80 (18) | 200 (7.90) | 2.5 (0.10) | 50 (1.97) | | |
| BM-N1436 | 100 | <--> | BM-N1436M | 1000 | <--> | 180 (40) | 140 (5.51) | 3.6 (0.14) | 33 (1.30) | | |
| BM-N2036 | 100 | <--> | Not available in bulk pack | | | 180 (40) | 200 (7.87) | 3.6 (0.14) | 50 (1.97) | | |
| BM-N2936 | 100 | <--> | BM-N2936M | 1000 | <--> | 180 (40) | 290 (11.42) | 3.6 (0.14) | 76 (2.99) | | |
| BM-N3736 | 100 | <--> | Not available in bulk pack | | | 180 (40) | 370 (14.57) | 3.6 (0.14) | 102 (4.02) | | |
| BM-N1648 | 100 | <--> | Not available in bulk pack | | | 220 (50) | 160 (6.30) | 4.8 (0.19) | 38 (1.50) | | |
| BM-N1948 | 100 | <--> | Not available in bulk pack | | | 220 (50) | 190 (7.48) | 4.8 (0.19) | 43 (1.69) | | |
| BM-N3048 | 100 | <--> | BM-N3048M | 1000 | <--> | 220 (50) | 300 (11.81) | 4.8 (0.19) | 76 (2.99) | | |
| BM-N3748 | 100 | <--> | Not available in bulk pack | | | 220 (50) | 370 (14.57) | 4.8 (0.19) | 102 (4.02) | | |
| BM-N3776 | 100 | <--> | Not available in bulk pack | | | 540 (120) | 370 (14.57) | 7.6 (0.30) | 102 (4.02) | | |
| BM-N7190 | 100 | <--> | Not available in bulk pack | | | 790 (175) | 710 (27.95) | 9 (0.35) | 190 (7.48) | | |
| BM-N8190 | 100 | <--> | Not available in bulk pack | | | 790 (175) | 810 (31.90) | 9 (0.35) | 239 (9.41) | | |

Cable Ties

Lashing Ties

Resistant to oils, grease, solvents and petroleum products.

* BM-N2412, BM-N4912, BM-N7412 are UL recognized, File E223175.

*No UL recognition on BM-N8912 or BM-N1012.

BM-N2412



| Lashing Ties, Black Nylon 6.6 | | | | | | | | | | |
|-------------------------------|------------------|-------|----------------------------|------------------|-------|------------------------------------|-----------------|----------------|-------------------------------|--------------------|
| Part Number | Package Quantity | Price | Part Number | Package Quantity | Price | Min. Loop Tensile Strength N (lbs) | Length mm (in.) | Width mm (in.) | Max. Bundle Diameter mm (in.) | Installation Tools |
| BM-N2412 | 100 | <---> | Not available in bulk pack | | | 1120 (250) | 240 (9.45) | 12.6 (0.50) | 50 (1.97) | Hand install only |
| BM-N4912 | 100 | <---> | Not available in bulk pack | | | 1120 (250) | 490 (19.29) | 12.6 (0.50) | 135 (5.32) | |
| BM-N7412 | 100 | <---> | Not available in bulk pack | | | 1120 (250) | 740 (29.13) | 12.6 (0.50) | 204 (8.03) | |
| *BM-N8912 | 100 | <---> | Not available in bulk pack | | | 1120 (250) | 890 (35.04) | 12.6 (0.50) | 248 (9.76) | |
| *BM-N1012 | 100 | <---> | Not available in bulk pack | | | 1120 (250) | 1040 (40.94) | 12.6 (0.50) | 295 (11.61) | |

Releasable Ties

Easy-release tab for removing, repositioning or reuse.

BM-R1576



| Releasable Cable Ties, Natural Nylon 6.6 | | | | | | | | | | |
|--|------------------|-------|----------------------------|------------------|-------|------------------------------------|-----------------|----------------|-------------------------------|--------------------|
| Part Number | Package Quantity | Price | Part Number | Package Quantity | Price | Min. Loop Tensile Strength N (lbs) | Length mm (in.) | Width mm (in.) | Max. Bundle Diameter mm (in.) | Installation Tools |
| BM-R1576 | 100 | <---> | Not available in bulk pack | | | 220 (50) | 150 (5.9) | 7.6 (0.30) | 35 (1.38) | Hand install only |
| BM-R2076 | 100 | <---> | Not available in bulk pack | | | 220 (50) | 200 (7.9) | 7.6 (0.30) | 50 (1.97) | |
| BM-R3076 | 100 | <---> | Not available in bulk pack | | | 220 (50) | 300 (11.8) | 7.6 (0.30) | 80 (3.15) | |

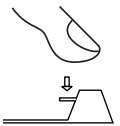

Mounting Head Ties

One-piece mounting head and cable tie. No separate mounting accessory needed.

• UL Recognized, File E223175

BM-H1125



| Mounting Head Cable Ties, Natural Nylon 6.6 | | | | | | | | | | | |
|---|------------------|-------|----------------------------|------------------|-------|------------------------------------|-----------------|----------------|---|-------------------------------|---|
| Part Number | Package Quantity | Price | Part Number | Package Quantity | Price | Min. Loop Tensile Strength N (lbs) | Length mm (in.) | Width mm (in.) | Mounting Head Hole mm (in.) | Max. Bundle Diameter mm (in.) | Accessories and Installation Tools |
| BM-H1125 | 100 | <---> | Not available in bulk pack | | | 80 (18) | 110 (4.33) | 2.5 (0.10) | 3.25 (0.13) for #5 screw (not included) | 22 (0.87) | BM-B0901, BM-N0901, BM-B0902, BM-N0902, BM-B0903, BM-N0903, BM-1100 |
| BM-H2048 | 100 | <---> | Not available in bulk pack | | | 220 (50) | 200 (7.87) | 4.8 (0.19) | 5.3 (0.21) for #10 screw (not included) | 50 (1.97) | BM-B0902, BM-N0902, BM-B0903, BM-N0903, BM-1100 |
| BM-H3076 | 100 | <---> | Not available in bulk pack | | | 540 (121) | 305 (12.01) | 7.6 (0.30) | 5.8 (0.23) for #12 screw (not included) | 76 (3.00) | BM-1101 |

UV-Resistant Ties

For outdoor installation requiring high tensile strength and high locking system resistance. Resistant to oils, grease, atmospheric agents and salt. Using the hand tool P/N BM-1101 is required due to the amount of strength needed for bundling.

- Material: Nylon 12
- Operating Temperature: -22° to 176°F (-30° to 80°C)
- Self-extinguishing UL 94-HB
- CE and RoHS compliant



BM-N1890

BM-N2690

| UV Resistant Cable Ties, Black Nylon 12 | | | | | | | | | | |
|---|------------------|-------|----------------------------|------------------|-------|------------------------------------|-----------------|----------------|-------------------------------|--------------------|
| Part Number | Package Quantity | Price | Part Number | Package Quantity | Price | Min. Loop Tensile Strength N (lbs) | Length mm (in.) | Width mm (in.) | Max. Bundle Diameter mm (in.) | Installation Tools |
| BM-N1890 | 100 | <---> | Not available in bulk pack | | | 350 (79) | 180 (7.1) | 9 (0.35) | 43 (1.69) | BM-1101 |
| BM-N2690 | 100 | <---> | Not available in bulk pack | | | 500 (112) | 265 (10.4) | 9 (0.35) | 65 (2.56) | |
| BM-N3690 | 100 | <---> | Not available in bulk pack | | | 500 (112) | 360 (14.2) | 9 (0.35) | 93 (3.67) | |

Cable Ties

Identification Tags

Write-on marker ties for quick identification of wires and cables.

- Vertical tags in one, two or three-leg options
- Horizontal tags in single top-mount or bottom-mount options



| ID Tag Style Cable Ties, Natural Nylon 6.6 | | | | | | | | | | | | |
|--|------------------|-------|----------------------------|------------------|-------|------------------------------------|-----------------|----------------|---------------------------|---|--------------------|--|
| Part Number | Package Quantity | Price | Part Number | Package Quantity | Price | Min. Loop Tensile Strength N (lbs) | Length mm (in.) | Width mm (in.) | Max. Bundle Dia. mm (in.) | Tag Description mm (in.) | Installation Tools | Mounting Accessories |
| BM-T12248 | 100 | <---> | Not available in bulk pack | | | 220 (50) | 220 (8.66) | 4.8 (0.19) | 54 (2.13) | One leg 13x28 (0.51x1.10) vertical ID tag | BM-1100 | BM-B0902, BM-N0902 BM-B0903, BM-N0903 |
| BM-T22248 | 100 | <---> | Not available in bulk pack | | | 220 (50) | 220 (8.66) | 4.8 (0.19) | 54 (2.13) | Two leg 30x28 (1.18x1.10) vertical ID tag | | BM-B0902, BM-N0902 BM-B0903, BM-N0903 |
| BM-T32248 | 100 | <---> | Not available in bulk pack | | | 220 (50) | 220 (8.66) | 4.8 (0.19) | 54 (2.13) | Three leg 47x28 (1.85 x1.10) vertical ID tag | | BM-B0902, BM-N0902 BM-B0903, BM-N0903 |
| BM-T23048 | 100 | <---> | Not available in bulk pack | | | 220 (50) | 300 (11.81) | 4.8 (0.19) | 76 (2.99) | Two leg 30x28 (1.18x1.10) vertical ID tag | | BM-B0902, BM-N0902 BM-B0903, BM-N0903 |
| BM-T33048 | 100 | <---> | Not available in bulk pack | | | 220 (50) | 300 (11.81) | 4.8 (0.19) | 76 (2.99) | Three leg 47x28 (1.85 x1.10) vertical ID tag | | BM-B0902, BM-N0902 BM-B0903, BM-N0903 |
| BM-T11125 | 100 | <---> | Not available in bulk pack | | | 80 (18) | 110 (4.33) | 2.5 (0.10) | 18 (0.71) | One leg 20.4x9.1 (0.80x0.36) top-mounted horizontal ID tag | | BM-B0901, BM-N0901 BM-B0902, BM-N0902 BM-B0903, BM-N0903 |
| BM-T21025 | 100 | <---> | Not available in bulk pack | | | 80 (18) | 100 (3.94) | 2.5 (0.10) | 18 (0.71) | One leg 25.4x8 (1.0x0.31) bottom-mounted horizontal ID tag | | BM-B0901, BM-N0901 BM-B0902, BM-N0902 BM-B0903, BM-N0903 |
| BM-T22025 | 100 | <---> | Not available in bulk pack | | | 80 (18) | 200 (7.87) | 2.5 (0.10) | 50 (1.97) | One leg 25.4x8 (1.0x0.31) bottom-mounted horizontal ID tag | | BM-B0901, BM-N0901 BM-B0902, BM-N0902 BM-B0903, BM-N0903 |

Cable Tie Accessories and Tools

Cable Tie Mounts

- 4-way entry for convenient cable tie installation
- Adhesive-mount - for use where drilling mounting holes is not possible
- Screw-mount - #6 Flathead screw recommended (not included)



Adhesive mount Screw mount

| Cable Tie Mounts, Nylon 6.6 | | | | | | |
|-----------------------------|---------|------------------|-------|---------------------|-----------------------------|-----------------|
| Part Number | Color | Package Quantity | Price | Size mm (in.) | Use with Cable Ties mm(in.) | Mounting Method |
| BM-B0901 | Natural | 100 | <---> | 19x19.0 (0.75x0.75) | 3.6 (0.14) wide, max. | Adhesive |
| BM-N0901 | Black | 100 | <---> | 19x19.0 (0.75x0.75) | 3.6 (0.14) wide, max. | Adhesive |
| BM-B0902 | Natural | 100 | <---> | 28x28 (1.1x1.1) | 4.8 (0.19) wide, max. | Adhesive |
| BM-N0902 | Black | 100 | <---> | 28x28 (1.1x1.1) | 4.8 (0.19) wide, max. | Adhesive |
| BM-B0903 | Natural | 100 | <---> | 28x28 (1.1x1.1) | 4.8 (0.19) wide, max. | screw |
| BM-N0903 | Black | 100 | <---> | 28x28 (1.1x1.1) | 4.8 (0.19) wide, max. | screw |

Cable Tie Hand Tools

| Cable Tie Installation Tools | | | | |
|------------------------------|-------|------------------|-------|---|
| Part Number | Color | Package Quantity | Price | Description |
| BM-1100 | Blue | 1 | <---> | For use with cable ties from 2.5 mm (0.10 in.) wide to 4.8 mm (0.19 in.) wide |
| BM-1101 | Red | 1 | <---> | For use with cable ties from 7.6 mm (0.30 in.) wide to 9 mm (0.35 in.) wide |

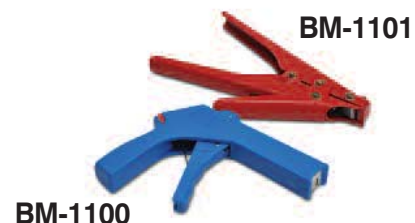

BM-1100

BM-1101

Wire – THHN Type and MTW Type



THHN10GYL



THHN4BK



MTW16WH



MTW10WH

Applications

Type **THHN** building wire is intended for general purpose applications as defined by the National Electrical Code (NEC). It is appropriate for new construction or rewiring for 600-volt applications. When used as type THHN, the conductor is suitable for use in wet or dry locations at temperatures not to exceed 90°C or not to exceed 75°C in oil or coolants. When used as type MTW, the conductor is suitable for use in dry locations at 90°C, or not to exceed 60°C in wet locations or where exposed to oils or coolants.

Type **MTW** conductors are primarily used in control cabinets, in machine tool applications and appliance wiring applications at temperatures -25°C to 90°C. They comply with the National Electrical Code (NEC) and NFPA Standard 79. Voltage rating for all applications is 600 volts.

THHN and MTW wire is sold in 500 foot spools; certain sizes are also available in 2500 foot reels.

Features

Conductors

- THHN: stranded, uncoated copper conductors per ASTM-B3, ASTM-B787 and ASTM-B8
- MTW: bare, annealed copper per ASTM-B3, -B8 and -B787

Insulation

Color-coded, Polyvinyl Chloride (PVC) heat- and moisture-resistant, flame-retardant compound per UL 1063 and UL 83

Jacket

THHN wire has a tough, polyamide, Nylon outer covering per UL 1063 and UL 83. Slick Nylon outer jacket for easy pulling

Ratings

VW-1 rated 14 AWG - 4 AWG

6 AWG and larger is rated for sunlight resistance in all colors. All sizes are rated "gasoline and oil resistant II."

Please Note: Our prices on wire are closely tied to the market price for copper. This allows us to offer the best savings possible if conditions are favorable; however, it also means that our prices may increase if market conditions warrant.

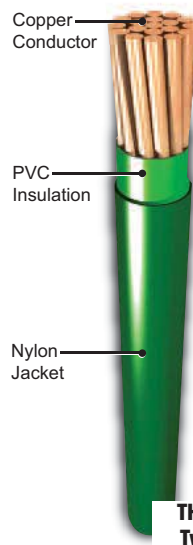

THHN Type

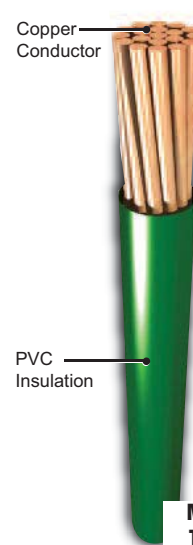

MTW Type

Wire – THHN Type

| Type THHN Wire Specifications | | | | | | | | | | | |
|-------------------------------|-------------------|---|-------------------------------|-------|--------------------------|------|------------------------|------|------|-------------------------------------|---|
| Size (AWG or kcmil) | Number of Strands | Cross-sectional Area (mm ²) | Insulation Thickness (inches) | | Overall Outside Diameter | | Allowable Ampacities * | | | Approximate Weight (lbs) 500'/2500' | Standard Packaging spool/reel |
| | | | PVC | Nylon | (inches) | (mm) | 60°C | 75°C | 90°C | | |
| 14 | 19 | 6.258 | 0.015 | 0.004 | 0.109 | 2.77 | 15 | 15 | 15 | 7.8/42.2 | 500' or 2500'. Some colors not offered in 2500' reel. |
| 12 | 19 | 8.581 | 0.015 | 0.004 | 0.127 | 3.23 | 20 | 20 | 20 | 11.7/61.4 | |
| 10 | 19 | 13.61 | 0.020 | 0.004 | 0.160 | 4.07 | 30 | 30 | 30 | 18.7 | 500' |
| 8 | 19 | 23.61 | 0.030 | 0.005 | 0.212 | 5.39 | 40 | 50 | 55 | 31.4 | |
| 6 | 19 | 32.71 | 0.030 | 0.005 | 0.248 | 6.30 | 55 | 65 | 75 | 48.5 | |
| 4 | 19 | 53.16 | 0.040 | 0.006 | 0.317 | 8.06 | 70 | 85 | 95 | 75.4 | |

*Note: Allowable ampacity shown above is per the 2005 National Electrical Code. The above data is approximate and subject to normal manufacturing tolerances.

| Type THHN Wire | | | | | | |
|------------------|---------------------|--------|--|-------------------|----------------|-------|
| Part Number | Color | Gauge | Description | Spool/Reel Length | Approx. Weight | Price |
| THHN14BK | Black | 14 AWG | Type THHN copper wire, 19 strands, 600 Volts | 500' | 7.8 lbs. | <--> |
| THHN14WH | White | | | | | <--> |
| THHN14RD | Red | | | | | <--> |
| THHN14BL | Blue | | | | | <--> |
| THHN14GN | Green | | | | | <--> |
| THHN14YL | Yellow | | | | | <--> |
| THHN14OR | Orange | | | | | <--> |
| THHN14BN | Brown | | | | | <--> |
| THHN14PL | Purple | | | | | <--> |
| THHN14GY | Gray | | | | | <--> |
| THHN14GYL | Green/Yellow stripe | | | | | <--> |
| THHN14BW | Blue/White stripe | | | | | <--> |
| THHN12BK | Black | 12 AWG | Type THHN copper wire, 19 strands, 600 Volts | 500' | 11.7 lbs | <--> |
| THHN12WH | White | | | | | <--> |
| THHN12RD | Red | | | | | <--> |
| THHN12BL | Blue | | | | | <--> |
| THHN12GN | Green | | | | | <--> |
| THHN12YL | Yellow | | | | | <--> |
| THHN12OR | Orange | | | | | <--> |
| THHN12BN | Brown | | | | | <--> |
| THHN12GY | Gray | | | | | <--> |
| THHN12GYL | Green/Yellow stripe | | | | | <--> |
| THHN10BK | Black | 10 AWG | Type THHN copper wire, 19 strands, 600 Volts | 500' | 18.7 lbs | <--> |
| THHN10WH | White | | | | | <--> |
| THHN10GN | Green | | | | | <--> |
| THHN10YL | Yellow | | | | | <--> |
| THHN10OR | Orange | | | | | <--> |
| THHN10BN | Brown | | | | | <--> |
| THHN10GYL | Green/Yellow stripe | <--> | | | | |
| THHN8BK | Black | 8 AWG | Type THHN copper wire, 19 strands, 600 Volts | 500' | 31.4lbs | <--> |
| THHN8GN | Green | | | | | <--> |
| THHN8GYL | Green/Yellow stripe | | | | | <--> |
| THHN6BK | Black | 6 AWG | Type THHN copper wire, 19 strands, 600 Volts | 500' | 48.5 lbs | <--> |
| THHN4BK | Black | 4 AWG | Type THHN copper wire, 19 strands, 600 Volts | 500' | 75.4 lbs | <--> |

Wire – THHN Type

| Type THHN Wire | | | | | | |
|-------------------|-------------------|--------|--|-------------------|----------------|-------|
| Part Number | Color | Gauge | Description | Spool/Reel Length | Approx. Weight | Price |
| THHN14BK25 | Black | 14 AWG | Type THHN copper wire, 19 strands, 600 Volts | 2500' | 42.2 lbs. | <--> |
| THHN14WH25 | White | | | | | <--> |
| THHN14RD25 | Red | | | | | <--> |
| THHN14BL25 | Blue | | | | | <--> |
| THHN14GN25 | Green | | | | | <--> |
| THHN14YL25 | Yellow | | | | | <--> |
| THHN14OR25 | Orange | | | | | <--> |
| THHN14BN25 | Brown | | | | | <--> |
| THHN14PL25 | Purple | | | | | <--> |
| THHN14GY25 | Gray | | | | | <--> |
| THHN14BW25 | Blue/White stripe | | | | | <--> |
| THHN12BK25 | Black | 12 AWG | Type THHN copper wire, 19 strands, 600 Volts | 2500' | 61.4 lbs. | <--> |
| THHN12WH25 | White | | | | | <--> |
| THHN12RD25 | Red | | | | | <--> |
| THHN12BL25 | Blue | | | | | <--> |
| THHN12GN25 | Green | | | | | <--> |
| THHN12YL25 | Yellow | | | | | <--> |
| THHN12OR25 | Orange | | | | | <--> |
| THHN12BN25 | Brown | <--> | | | | |

Wire – MTW Type

| Type MTW Wire Specifications | | | | | | | | | |
|------------------------------|-------------------|---|-------------------------------|--------------------------|------|------------------------|------|-------------------------------------|--|
| Size (AWG or kcmil) | Number of Strands | Cross-sectional Area (mm ²) | Insulation Thickness (inches) | Overall Outside Diameter | | Allowable Ampacities*† | | Approximate Weight (lbs) 500'/2500' | Standard Packaging spool/reel |
| | | | PVC | (inches) | (mm) | 60°C | 75°C | | |
| 18 | 16 | 6.113 | 0.030 | 0.110 | 2.79 | 6 | 6 | 4.6/26.8 | 500' or 2500'. Some colors not offered in 2500' reel. |
| 16 | 26 | 7.645 | 0.030 | 0.123 | 3.12 | 8 | 8 | 6.5/34.4 | |
| 14 | 19 | 8.814 | 0.030 | 0.132 | 3.35 | 15 | 15 | 9.0/46.8 | |
| 12 | 19 | 11.581 | 0.030 | 0.151 | 3.84 | 20 | 20 | 13.2/71.0 | |
| 10 | 19 | 21.319 | 0.030 | 0.205 | 5.21 | 30 | 30 | 20.9 | 500' |

*Note: Allowable ampacity shown above is per the 2005 National Electrical Code. †Note: MTW conductor ampacity based on Cooper conductors with 60°C and 75°C as specified by NFPA79. The above data is approximate and subject to normal manufacturing tolerances.

| Type MTW Wire | | | | | | | |
|---------------|------------|--------|---|-------------------|----------------|-------|------|
| Part Number | Color | Gauge | Description | Spool/Reel Length | Approx. Weight | Price | |
| MTW18BK | Black | 18 AWG | Type MTW copper wire, 16 strands, 600 Volts | 500' | 4.6 lbs | <--> | |
| MTW18WH | White | | | | | | <--> |
| MTW18RD | Red | | | | | | <--> |
| MTW18BL | Blue | | | | | | <--> |
| MTW18GN | Green | | | | | | <--> |
| MTW18YL | Yellow | | | | | | <--> |
| MTW18OR | Orange | | | | | | <--> |
| MTW18BN | Brown | | | | | | <--> |
| MTW18PL | Purple | | | | | | <--> |
| MTW18GY | Gray | | | | | | <--> |
| MTW18BW | Blue/White | | | | | | <--> |
| MTW16BK | Black | 16 AWG | Type MTW copper wire, 26 strands, 600 Volts | 500' | 6.5 lbs | <--> | |
| MTW16WH | White | | | | | | <--> |
| MTW16RD | Red | | | | | | <--> |
| MTW16BL | Blue | | | | | | <--> |
| MTW16GN | Green | | | | | | <--> |
| MTW16YL | Yellow | | | | | | <--> |
| MTW16OR | Orange | | | | | | <--> |
| MTW16BN | Brown | | | | | | <--> |
| MTW16PL | Purple | | | | | | <--> |
| MTW16GY | Gray | | | | | | <--> |
| MTW16BW | Blue/White | | | | | | <--> |

Wire – MTW Type

| Type MTW Wire | | | | | | |
|----------------|------------|--------|---|-------------------|----------------|-------|
| Part Number | Color | Gauge | Description | Spool/Reel Length | Approx. Weight | Price |
| MTW14BK | Black | 14 AWG | Type MTW copper wire, 19 strands, 600 Volts | 500' | 9.0 lbs | <---> |
| MTW14WH | White | | | | | <---> |
| MTW14RD | Red | | | | | <---> |
| MTW14BL | Blue | | | | | <---> |
| MTW14GN | Green | | | | | <---> |
| MTW14YL | Yellow | | | | | <---> |
| MTW14OR | Orange | | | | | <---> |
| MTW14BN | Brown | | | | | <---> |
| MTW14PL | Purple | | | | | <---> |
| MTW14GY | Gray | | | | | <---> |
| MTW14BW | Blue/White | | | | | <---> |
| MTW12BK | Black | 12 AWG | Type MTW copper wire, 19 strands, 600 Volts | 500' | 13.2 lbs | <---> |
| MTW12WH | White | | | | | <---> |
| MTW12RD | Red | | | | | <---> |
| MTW12BL | Blue | | | | | <---> |
| MTW12GN | Green | | | | | <---> |
| MTW12YL | Yellow | | | | | <---> |
| MTW12OR | Orange | | | | | <---> |
| MTW12BN | Brown | <---> | | | | |
| MTW12GY | Gray | <---> | | | | |
| MTW10BK | Black | 10 AWG | Type MTW copper wire, 19 strands, 600 Volts | 500' | 20.9 lbs | <---> |
| MTW10WH | White | | | | | <---> |
| MTW10GN | Green | | | | | <---> |
| MTW10YL | Yellow | | | | | <---> |
| MTW10OR | Orange | | | | | <---> |
| MTW10BN | Brown | <---> | | | | |

Wire – MTW Type

| Type MTW Wire | | | | | |
|------------------|-------------------|---|-------------------|----------------|-------|
| Part Number | Color | Description | Spool/Reel Length | Approx. Weight | Price |
| MTW18BK25 | Black | Type MTW copper wire, 18 AWG, 16 strands, 600 Volts | | 26.8 lbs | <--> |
| MTW18WH25 | White | | | | <--> |
| MTW18RD25 | Red | | | | <--> |
| MTW18BL25 | Blue | | | | <--> |
| MTW18GN25 | Green | | | | <--> |
| MTW18YL25 | Yellow | | | | <--> |
| MTW18OR25 | Orange | | | | <--> |
| MTW18BN25 | Brown | | | | <--> |
| MTW18PL25 | Purple | | | | <--> |
| MTW18GY25 | Gray | | | | <--> |
| MTW18BW25 | Blue/White stripe | | | | <--> |
| MTW16BK25 | Black | Type MTW copper wire, 16 AWG, 26 strands, 600 Volts | 2500' | 34.4 lbs | <--> |
| MTW16WH25 | White | | | | <--> |
| MTW16RD25 | Red | | | | <--> |
| MTW16BL25 | Blue | | | | <--> |
| MTW16GN25 | Green | | | | <--> |
| MTW16YL25 | Yellow | | | | <--> |
| MTW16OR25 | Orange | | | | <--> |
| MTW16BN25 | Brown | | | | <--> |
| MTW16PL25 | Purple | | | | <--> |
| MTW16GY25 | Gray | | | | <--> |
| MTW16BW25 | Blue/White stripe | | | | <--> |
| MTW14BK25 | Black | Type MTW copper wire, 14 AWG, 19 strands, 600 Volts | | 46.8 lbs | <--> |
| MTW14WH25 | White | | | | <--> |
| MTW14RD25 | Red | | | | <--> |
| MTW14BL25 | Blue | | | | <--> |
| MTW14GN25 | Green | | | | <--> |
| MTW14YL25 | Yellow | | | | <--> |
| MTW14OR25 | Orange | | | | <--> |
| MTW14BN25 | Brown | | | | <--> |
| MTW14PL25 | Purple | | | | <--> |
| MTW14GY25 | Gray | | | | <--> |
| MTW14BW25 | Blue/White stripe | | | | <--> |
| MTW12BK25 | Black | Type MTW copper wire, 12 AWG, 19 strands, 600 Volts | | 71.0 lbs | <--> |

Company Information

Systems Overview

Programmable Controllers

Field I/O

Software

C-more & other HMI

Drives

Soft Starters

Motors & Gearbox

Steppers/ Servos

Motor Controls

Proximity Sensors

Photo Sensors

Limit Switches

Encoders

Current Sensors

Pressure Sensors

Temperature Sensors

Pushbuttons/ Lights

Process

Relays/ Timers

Comm.

Terminal Blocks & Wiring

Power

Circuit Protection

Enclosures

Tools

Pneumatics

Safety

Appendix

Product Index

Part # Index

Wire – TFFN Type



TFFN16WH

Applications

Type TFFN (stranded) conductors are primarily used as fixture wire as specified by the National Electrical Code (NEC), at temperatures not to exceed 90°C in dry locations. Voltage rating is 600 volts.

TFFN wire is sold in 500 foot spools; certain sizes are also available in 2500 foot reels.

Features

Conductors

Stranded, uncoated copper conductors per ASTM-B3, ASTM-B787 and ASTM-B8

Insulation

Color-coded Polyvinyl Chloride (PVC) heat- and moisture-resistant, flame-retardant compound per UL-1063 and UL-83

Jacket

Tough, polyamide, nylon outer covering per UL-1063 and UL-83. Slick Nylon outer jacket for easy pulling.

Ratings

VW-1 rated and rated "gasoline and oil resistant II"

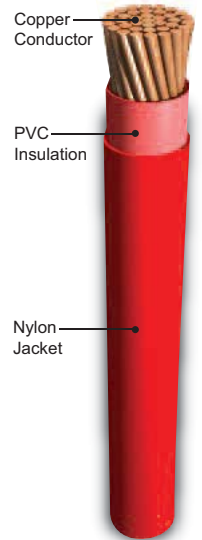

TFFN Type

| Type TFFN Wire Specifications | | | | | | | | | |
|-------------------------------|-------------------|--|-------------------------------|---------------------------------|--------------------------|-------|-----------------------|---------------------------------|-------------------------------|
| Size (AWG or kcmil) | Number of Strands | Cross-sectional Area (mm ²) (According to NEC) | Insulation Thickness (inches) | Nylon Jacket Thickness (inches) | Overall Outside Diameter | | Allowable Ampacities* | Approx. Weight (lbs) 500'/2500' | Standard Packaging spool/reel |
| | | | | | (inches) | (mm) | | | |
| 18 | 16 | 3.548 | 0.015 | 0.004 | 0.088 | 2.24 | 6 | 4/20 | 500' or 2500' |
| 16 | 26 | 4.645 | 0.015 | 0.004 | 0.101 | 2.545 | 8 | 5.5/27.5 | |

**Note: Allowable ampacity shown above is per the 2005 National Electrical Code, Section 402, Table 402.5. The above data is approximate and subject to normal manufacturing tolerances.*

| Type TFFN Wire | | | | | | |
|----------------|------------|--------|--|-------------------|----------------|--------|
| Part Number | Color | Gauge | Description | Spool/Reel Length | Approx. Weight | Price |
| TFFN18BK | Black | 18 AWG | Type TFFN copper wire, 16 strands, 600 Volts | 500' | 4 lbs | <--> |
| TFFN18WH | White | | | | | <--> |
| TFFN18RD | Red | | | | | <--> |
| TFFN18BL | Blue | | | | | <--> |
| TFFN18GN | Green | | | | | <--> |
| TFFN18YL | Yellow | | | | | <--> |
| TFFN18OR | Orange | | | | | <--> |
| TFFN18BN | Brown | | | | | <--> |
| TFFN18PL | Purple | | | | | <--> |
| TFFN18GY | Gray | | | | | <--> |
| TFFN18BW | Blue/White | | | | | <--> |
| TFFN16BK | Black | | | | | 16 AWG |
| TFFN16WH | White | <--> | | | | |
| TFFN16RD | Red | <--> | | | | |
| TFFN16BL | Blue | <--> | | | | |
| TFFN16GN | Green | <--> | | | | |
| TFFN16YL | Yellow | <--> | | | | |
| TFFN16OR | Orange | <--> | | | | |
| TFFN16BN | Brown | <--> | | | | |
| TFFN16GY | Gray | <--> | | | | |
| TFFN16BW | Blue/White | <--> | | | | |

Wire – TFFN Type

| Type TFFN Wire | | | | | | |
|-------------------|------------|--------|--|-------------------|----------------|-------|
| Part Number | Color | Gauge | Description | Spool/Reel Length | Approx. Weight | Price |
| TFFN18BK25 | Black | 18 AWG | Type TFFN copper wire, 16 strands, 600 Volts | 2500' | 20 lbs | <--> |
| TFFN18WH25 | White | | | | | <--> |
| TFFN18RD25 | Red | | | | | <--> |
| TFFN18BL25 | Blue | | | | | <--> |
| TFFN18GN25 | Green | | | | | <--> |
| TFFN18YL25 | Yellow | | | | | <--> |
| TFFN18OR25 | Orange | | | | | <--> |
| TFFN18BN25 | Brown | | | | | <--> |
| TFFN18PL25 | Purple | | | | | <--> |
| TFFN18GY25 | Gray | | | | | <--> |
| TFFN18BW25 | Blue/White | | | | | <--> |
| TFFN16BK25 | Black | 16 AWG | Type TFFN copper wire, 26 strands, 600 Volts | 2500' | 27.5 lbs | <--> |
| TFFN16WH25 | White | | | | | <--> |
| TFFN16RD25 | Red | | | | | <--> |
| TFFN16BL25 | Blue | | | | | <--> |
| TFFN16GN25 | Green | | | | | <--> |
| TFFN16YL25 | Yellow | | | | | <--> |
| TFFN16OR25 | Orange | | | | | <--> |
| TFFN16BN25 | Brown | | | | | <--> |
| TFFN16PL25 | Purple | | | | | <--> |
| TFFN16GY25 | Gray | | | | | <--> |
| TFFN16BW25 | Blue/White | | | | | <--> |

Wire – Gauge Conversion Tables

| American Wire Gauge Conversion Chart* | | | |
|---|-----------------------|------------|-----------------------|
| This cross reference shows equivalent nominal values. Actual cross sections may vary. | | | |
| AWG | mm² | AWG | mm² |
| 30 | 0.05 | 6 | 16 |
| 28 | 0.08 | 4 | 25 |
| 26 | 0.14 | 2 | 35 |
| 24 | 0.25 | 1 | 50 |
| 22 | 0.34 | 1/0 | 55 |
| 21 | 0.38 | 2/0 | 70 |
| 20 | 0.50 | 3/0 | 95 |
| 18 | 0.75 | 4/0 | 120 |
| 17 | 1.00 | 300MCM | 150 |
| 16 | 1.50 | 350MCM | 185 |
| 14 | 2.50 | 500MCM | 240 |
| 12 | 4 | 600MCM | 300 |
| 10 | 6 | 750MCM | 400 |
| 8 | 10 | 1000MCM | 500 |

***Note: Table shows commercially used equivalent values.**

You will find product MSDS information and a complete glossary of wire terminology on our Web site at <http://support.automationdirect.com/products/wire.html>

Flexible Cord

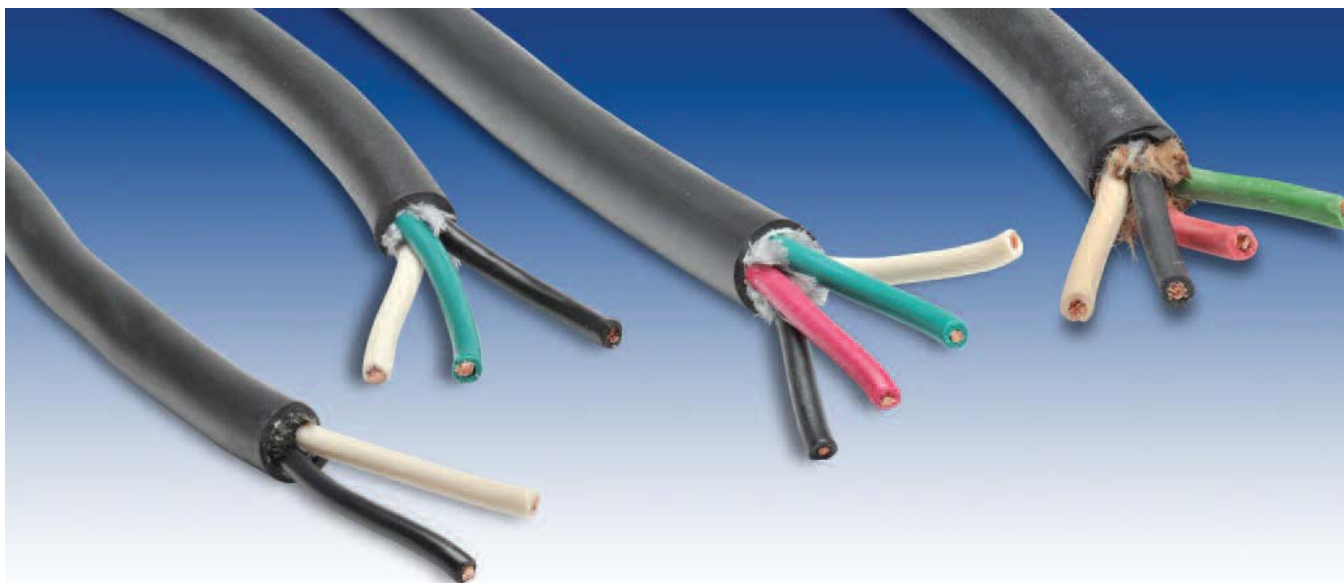

Type SJEOOW and SEOOO Flexible Cord

Applications

Type SJEOOW 300 Volt and type SEOOO 600 Volt flexible cords are permitted for use as specified by Article 400 and related articles of the National Electrical Code. Some typical applications include wiring for industrial machinery, washing machines and various other large appliances; heavy-duty tools; motors; and temporary electrical power and lighting installations for construction sites. Type SJEOOW and SEOOO cords are suitable for use in (i) dry locations not to exceed minimum -50°C (-58°F) or maximum 105°C (221°F) or (ii) wet locations or other applicable locations. S type cords may be completely immersed in water, or when exposed to oil or coolant at temperatures not to exceed 60°C (140°F). They are ideal for flex applications in harsh environments where the highest degree of oil resistance and extended service life are essential.

CONSTRUCTION

Type SJEOOW and Type SEOOO flexible cords are manufactured using bare flexible stranded Class K copper conductors, and heat, moisture and oil resistant **thermoplastic-elastomer (TPE)** insulation. The insulated conductors are cabled with non-wicking polypropylene fillers, with a tissue-paper separator wrapped around the assembly for easier removal. A heat, moisture and oil resistant flexible TPE jacket is extruded over the assembly to complete the construction.

Type W Flexible Cord

Applications

Type W 2000 Volt flexible cords are permitted for use as specified by Article 400 and related articles of the National Electrical Code. Some typical applications for Type W cords include industrial and light- to medium-duty mining applications; heavy-duty service as power supply cable; AC systems (grounded and ungrounded); mobile and portable electrical equipment; motor and battery leads. Four-conductor cables may be used on two- or three-phase AC systems with one conductor used for grounding. Temperature range is -40°C (-40°F) minimum to 90°C (194°F) maximum.

CONSTRUCTION

Type W flexible cords are manufactured using fully stranded bare copper conductors, premium-grade color-coded 90°C (194°F) insulation and black rubber 90°C (194°F) rated **chlorinated polyethylene (CPE)** jacket. A polyester or paper tape separates the copper conductors from the EPDM (Ethylene Propylene Diene Monomer) rubber insulation. The insulated conductors are assembled round with fillers as needed. The cable is covered with a black CPE (chlorinated polyethylene) rubber jacket. The jacket may be applied in two layers. Two-layer jackets are reinforced by a braid of synthetic material between the layers.

Flexible Cord Usage

These flexible cords can be suspended, but must be connected to devices and to fittings so that tension is not transmitted to joints or terminals (per section 400-10 of NEC codes in which strain relievers are recommended). When used to connect utilization equipment (such as power generators), to facilitate frequent interchange, that equipment must have an attached plug.

Flexible cords are not permitted to be run through walls, structural ceilings, suspended/dropped ceilings, floors, or to be attached to building surfaces.



Flexible Cord – Material Specifications

| Flexible Cord Material Specifications | | |
|---|-----------------------------------|------------------------------------|
| Type | W | SJE00W SE00W |
| Specification | CPE Rubber | TPE |
| General Specifications | | |
| UV and Ozone Resistance | Good | Good |
| Temperature | -40°C to 90°C (-40°F to 194°F) | -50°C to 105°C (-58°F to 221°F) |
| Cold Bend Test | -40°C | -40°C |
| Abrasion and Cut-through Resistance | Good | Good |
| Flexing (# of cycles) | 15,000 | 15,000 |
| Tensile Strength (psi) @ 200% elongation | 1,200 | 800 |
| Burn Resistance | Good | Good |
| Oxidation Resistance | Good | Good |
| Water Resistance | Good | Good |
| Weld Slag (Burn) Resistance | Good | Good |
| Flame Test | | |
| UL Test Standards | FT1 and FT2 | FT1 and FT2 |
| CSA Test Standards | FT5 | FT2 |
| Chemical Resistance | | |
| Acids | Good | Good |
| Alkalines | Good | Good |
| Alcohols | Good | Good |
| Most Solvents | Good | Good |
| Oils | Good | Good |
| Gasoline | Good | Good |
| Greases | Good | Good |

| Minimum Bending Radius | | | |
|---|-------------------------------------|-------------------------------|------------------------|
| Conductor Insulation Thickness (inches) | Overall Cable Diameter, inches [mm] | | |
| | 1.000 [25.4] and less | 1.001 to 2.000 [25.4 to 50.8] | 2.001 [50.82] and over |
| Minimum Bending Radius as a Multiple of Cable Diameter | | | |
| 0.169 [4.3] and smaller | 4 [101.6] | 5 [127.0] | 6 [152.4] |
| 0.170 [4.32] and larger | 5 [127.0] | 6 [152.4] | 7 [177.8] |

Note: Dimensions are in inches. 1 inch = 1,000 mils.

Flexible Cord – Type SJEOOW



Features

- TPE cord. 105°C (221°F), (thermoplastic-elastomer) 300 VAC maximum
- Rated as hard-usage service cord
- Approved for outdoor use
- May be completely immersed in water
- Premium oil resistance and flexibility

Conductors

Extra flexible, fully annealed, stranded, Class K copper per ASTM B-174

Insulation

Premium-grade, oil-resistant, color-coded TPE (thermoplastic-elastomer)

Jacket

Premium grade, oil-resistant, black TPE

Temperature range:

-50°C to 105°C (-58°F to 221°F)

Approvals

- UL Standard 62 for Flexible Cords File No. E46194
- CSA standard 22.2 No. 49 for Flexible Cords CSA File No. 224650 Meets CSA FT-2
- MIL Spec: JC 580B
- Meets Mine Safety and Health Admin (MSHA) flame resistance for mining applications
- OSHA
- RoHS compliant



Type SJEOOW 300 Volt Flexible Cord

| Part Number | AWG/ # of Conductors | Conductor Stranding (#/AWG) | Nominal Insulation Thickness in. [mm] | Nominal Overall Diameter in. [mm] | Ampacity | Spool/Coil Length ft. | Approximate Weight (lbs) | Price | |
|-------------------------|----------------------|-----------------------------|---------------------------------------|-----------------------------------|----------|-----------------------|--------------------------|-------|-------|
| SJEOOW-18-2BK250 | 18/2 | 16 X 30 | 0.03 [0.76] | 0.290 [7.36] | 10 | 250 | 11.0 | <---> | |
| SJEOOW-18-3BK250 | 18/3 | 16 X 30 | 0.03 [0.76] | 0.310 [7.87] | 10 | | 13.8 | <---> | |
| SJEOOW-18-4BK250 | 18/4 | 16 X 30 | 0.03 [0.76] | 0.335 [8.5] | 7 | | 16.5 | <---> | |
| SJEOOW-16-2BK250 | 16/2 | 26 X 30 | 0.03 [0.76] | 0.315 [8.0] | 13 | | 13.5 | <---> | |
| SJEOOW-16-3BK250 | 16/3 | 26 X 30 | 0.03 [0.76] | 0.330 [8.32] | 13 | | 16.8 | <---> | |
| SJEOOW-16-4BK250 | 16/4 | 26 X 30 | 0.03 [0.76] | 0.360 [9.14] | 10 | | 19.5 | <---> | |
| SJEOOW-14-2BK250 | 14/2 | 41 X 30 | 0.03 [0.76] | 0.345 [8.76] | 18 | | 17.0 | <---> | |
| SJEOOW-14-3BK250 | 14/3 | 41 X 30 | 0.03 [0.76] | 0.370 [9.14] | 18 | | 21.0 | <---> | |
| SJEOOW-14-4BK250 | 14/4 | 41 X 30 | 0.045 [1.14] | 0.400 [10.16] | 15 | | 26.0 | <---> | |
| SJEOOW-12-2BK250 | 12/2 | 65 X 30 | 0.045 [1.14] | 0.415 [10.54] | 25 | | 24.3 | <---> | |
| SJEOOW-12-3BK250 | 12/3 | 65 X 30 | 0.045 [1.14] | 0.430 [10.92] | 25 | | 30.8 | <---> | |
| SJEOOW-12-4BK20 | 12/4 | 65 X 30 | 0.045 [1.14] | 0.475 [12.06] | 20 | | 20 | 3.2 | <---> |
| SJEOOW-12-4BK50 | 12/4 | 65 X 30 | 0.045 [1.14] | 0.475 [12.06] | 20 | | 50 | 8.0 | <---> |
| SJEOOW-12-4BK250 | 12/4 | 65 X 30 | 0.045 [1.14] | 0.475 [12.06] | 20 | | 250 | 39.3 | <---> |
| SJEOOW-10-2BK250 | 10/2 | 104 X 30 | 0.045 [1.14] | 0.549 [13.94] | 30 | 41.5 | | <---> | |
| SJEOOW-10-3BK250 | 10/3 | 104 X 30 | 0.045 [1.14] | 0.580 [14.73] | 30 | 54.0 | | <---> | |
| SJEOOW-10-4BK20 | 10/4 | 104 X 30 | 0.045 [1.14] | 0.640 [16.256] | 25 | 20 | 5.3 | <---> | |
| SJEOOW-10-4BK50 | 10/4 | 104 X 30 | 0.045 [1.14] | 0.640 [16.256] | 25 | 50 | 13.2 | <---> | |
| SJEOOW-10-4BK250 | 10/4 | 104 X 30 | 0.045 [1.14] | 0.640 [16.256] | 25 | 250 | 69.0 | <---> | |

Ampacity values are based on NEC Table 400-5(A).

Please Note: Our prices on flexible cord are closely tied to the market price for copper. This allows us to offer the best savings possible if conditions are favorable; however, it also means that our prices may increase if market conditions warrant.

Color Code

| No. of Conductors | Color Sequence |
|-------------------|--------------------------|
| 2 | White, Black |
| 3 | White, Black, Green |
| 4 | White, Black, Green, Red |

Flexible Cord – Type SE00W

Features

- TPE cord, 105°C (221°F), (thermoplastic-elastomer) 600 VAC maximum
- Rated as extra hard-usage service cord
- Approved for outdoor use
- May be completely immersed in water
- Premium oil resistance and flexibility

Conductors

Extra flexible, fully annealed, stranded, Class K copper, per ASTM B-174

Insulation

Oil-resistant, 105°C (221°F), color-coded TPE (thermoplastic-elastomer)

Jacket

Premium grade, oil-resistant, black TPE. Temperature range: -50°C to 105°C (-58°F to 221°F)

Approvals

- UL Standard 62 for Flexible Cords File No. E46194
- CSA standard 22.2 No. 49 for Flexible Cords CSA File No. 224650 Meets CSA FT-2
- MIL Spec: JC 580B
- Meets Mine Safety and Health Admin (MSHA) flame resistance for mining applications
- OSHA
- RoHS compliant



| Type SE00W 600 Volt Flexible Cord | | | | | | | | |
|-----------------------------------|----------------------|-----------------------------|---------------------------------------|-----------------------------------|----------|----------------------|--------------------------|-------|
| Part Number | AWG/ # of Conductors | Conductor Stranding (#/AWG) | Nominal Insulation Thickness in. [mm] | Nominal Overall Diameter in. [mm] | Ampacity | Spool/Coil Length ft | Approximate Weight (lbs) | Price |
| SE00W-18-2BK250 | 18/2 | 16 X 30 | 0.03 [0.76] | 0.345 [8.76] | 10 | 250 | 14.8 | <--> |
| SE00W-18-3BK250 | 18/3 | 16 X 30 | 0.03 [0.76] | 0.365 [9.27] | 10 | | 17.3 | <--> |
| SE00W-18-4BK20 | 18/4 | 16 X 30 | 0.03 [0.76] | 0.395 [10] | 7 | 20 | 1.6 | <--> |
| SE00W-18-4BK50 | 18/4 | 16 X 30 | 0.03 [0.76] | 0.395 [10] | 7 | 50 | 4.0 | <--> |
| SE00W-18-4BK250 | 18/4 | 16 X 30 | 0.03 [0.76] | 0.395 [10] | 7 | 250 | 20.3 | <--> |
| SE00W-16-2BK250 | 16/2 | 26 X 30 | 0.03 [0.76] | 0.370 [9.4] | 13 | | 17.8 | <--> |
| SE00W-16-3BK250 | 16/3 | 26 X 30 | 0.03 [0.76] | 0.390 [9.9] | 13 | 20 | 20.3 | <--> |
| SE00W-16-4BK20 | 16/4 | 26 X 30 | 0.03 [0.76] | 0.420 [10.67] | 10 | | 2.0 | <--> |
| SE00W-16-4BK50 | 16/4 | 26 X 30 | 0.03 [0.76] | 0.420 [10.67] | 10 | 50 | 5.0 | <--> |
| SE00W-16-4BK250 | 16/4 | 26 X 30 | 0.03 [0.76] | 0.420 [10.67] | 10 | 250 | 24.8 | <--> |
| SE00W-14-2BK250 | 14/2 | 41 X 30 | 0.045 [1.14] | 0.505 [12.82] | 18 | | 31.5 | <--> |
| SE00W-14-3BK250 | 14/3 | 41 X 30 | 0.045 [1.14] | 0.525 [13.335] | 18 | 20 | 37.3 | <--> |
| SE00W-14-4BK20 | 14/4 | 41 X 30 | 0.045 [1.14] | 0.575 [14.6] | 15 | | 3.4 | <--> |
| SE00W-14-4BK50 | 14/4 | 41 X 30 | 0.045 [1.14] | 0.575 [14.6] | 15 | 50 | 8.3 | <--> |
| SE00W-14-4BK250 | 14/4 | 41 X 30 | 0.045 [1.14] | 0.575 [14.6] | 15 | 250 | 45.8 | <--> |
| SE00W-12-2BK250 | 12/2 | 65 X 30 | 0.045 [1.14] | 0.570 [14.48] | 25 | | 40.8 | <--> |
| SE00W-12-3BK250 | 12/3 | 65 X 30 | 0.045 [1.14] | 0.595 [15.11] | 25 | 20 | 49.8 | <--> |
| SE00W-12-4BK20 | 12/4 | 65 X 30 | 0.045 [1.14] | 0.645 [16.38] | 20 | | 5.0 | <--> |
| SE00W-12-4BK50 | 12/4 | 65 X 30 | 0.045 [1.14] | 0.645 [16.38] | 20 | 50 | 12.0 | <--> |
| SE00W-12-4BK250 | 12/4 | 65 X 30 | 0.045 [1.14] | 0.645 [16.38] | 20 | 250 | 60.5 | <--> |
| SE00W-10-2BK250 | 10/2 | 104 X 30 | 0.045 [1.14] | 0.626 [15.9] | 30 | | 51.8 | <--> |
| SE00W-10-3BK250 | 10/3 | 104 X 30 | 0.045 [1.14] | 0.665 [16.89] | 30 | 20 | 64.8 | <--> |
| SE00W-10-4BK20 | 10/4 | 104 X 30 | 0.045 [1.14] | 0.705 [17.9] | 25 | | 6.0 | <--> |
| SE00W-10-4BK50 | 10/4 | 104 X 30 | 0.045 [1.14] | 0.705 [17.9] | 25 | 50 | 15.0 | <--> |
| SE00W-10-4BK250 | 10/4 | 104 X 30 | 0.045 [1.14] | 0.705 [17.9] | 25 | 250 | 79.0 | <--> |

Ampacity values are based on NEC® Table 400-5(A).

Please Note: Our prices on flexible cord are closely tied to the market price for copper. This allows us to offer the best savings possible if conditions are favorable; however, it also means that our prices may increase if market conditions warrant.

| Color Code | |
|-------------------|--------------------------|
| No. of Conductors | Color Sequence |
| 2 | White, Black |
| 3 | White, Black, Green |
| 4 | White, Black, Green, Red |

Flexible Cord – Type W Round

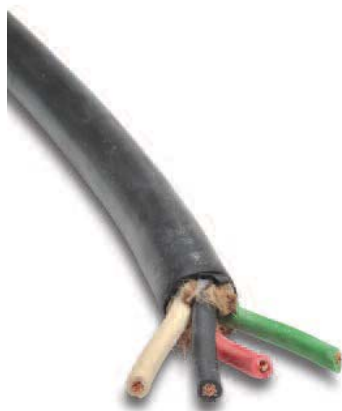

Features

- CPE cord, 90°C (194°F), (chlorinated polyethylene) 2000 VAC maximum
- Stands up to severe environmental conditions
- Excellent flexibility and impact resistance
- Resistant to exposure to oil, acid, alkalis, heat, moisture and most chemicals
- Cable core bound for superior flexibility and toughness

Conductors

Extra flexible, fully annealed, stranded, bare copper

Insulation

Premium-grade, color-coded, 90°C (194°F) EPDM (Ethylene Propylene Diene Monomer)

Jacket

Black Rubber CPE (chlorinated polyethylene), 90°C (194°F)

Temperature range:

-40°C to 90°C (-40°F to 194°F)

Approvals

- UL Type W, File No. E308664
- CSA File No. 236844. Meets FT-5 flame test
- Meets Mine Safety and Health Admin (MSHA) flame resistance for mining applications
- OSHA
- RoHS compliant



| Type W 2000 Volt Flexible Cord | | | | | | | | |
|--------------------------------|----------------------|------------------|---------------------------------------|-----------------------------------|----------|----------------------|--------------------------|-------|
| Part Number | AWG/ # of Conductors | Conductor Strand | Nominal Insulation Thickness in. [mm] | Nominal Overall Diameter in. [mm] | Ampacity | Spool/Coil Length ft | Approximate Weight (lbs) | Price |
| W-8-4BK10 | 8/4 | 133 | 0.06 [1.52] | 0.985 [25.02] | 65 | 10 | 6.0 | <---> |
| W-8-4BK20 | 8/4 | 133 | 0.06 [1.52] | 0.985 [25.02] | 65 | 20 | 12.5 | <---> |
| W-8-4BK25 | 8/4 | 133 | 0.06 [1.52] | 0.985 [25.02] | 65 | 25 | 15.5 | <---> |
| W-8-4BK50 | 8/4 | 133 | 0.06 [1.52] | 0.985 [25.02] | 65 | 50 | 30.5 | <---> |
| W-8-4BK75 | 8/4 | 133 | 0.06 [1.52] | 0.985 [25.02] | 65 | 75 | 46.0 | <---> |
| W-8-4BK100 | 8/4 | 133 | 0.06 [1.52] | 0.985 [25.02] | 65 | 100 | 119.0 | <---> |
| W-8-4BK150 | 8/4 | 133 | 0.06 [1.52] | 0.985 [25.02] | 65 | 150 | 151.0 | <---> |
| W-8-4BK250 | 8/4 | 133 | 0.06 [1.52] | 0.985 [25.02] | 65 | 250 | 229.0 | <---> |

Ampacity values are based on 90°C conductor and 30°C ambient temperature per NEC® Table 400-5(B).

Please Note: Our prices on flexible cord are closely tied to the market price for copper. This allows us to offer the best savings possible if conditions are favorable; however, it also means that our prices may increase if market conditions warrant.

| Color Code | |
|-------------------|--------------------------|
| No. of Conductors | Color Sequence |
| 4 | White, Black, Green, Red |

Multi-Conductor Flexible Control Cable



Multi-conductor flexible control cable from AutomationDirect is available in sizes from 18 AWG to 10 AWG with 3 to 41 unshielded conductors. Individual conductors are bare copper and stranded for flexibility, with black PVC/Nylon insulation and marked with numbers for easy identification. A convenient ground conductor is included in the conductor count of each cable and has insulation that is green with a yellow line. The cable's outer jacket is a flexible, premium grade PVC that is resistant to sunlight, oil, and moisture penetration, making these cables suitable for wet and dry locations as well as outdoors. Although not suitable for continuous flexing applications, these cables are ideal for both stationary and flexible applications with limited mechanical stress and free movement without any tensile stress, loads or forced movements.

With multiple ratings and approvals, AutomationDirect flexible multi-conductor control cable has the versatility to meet a wide range of industrial applications. Tray Cable Exposed Run, UL Type TC-ER, enables our cable to be installed between a cable tray and the utilization equipment or device without the need for metal conduit and/or armor resulting in installation and maintenance savings. With the Machine Tool Wire rating, UL Type MTW, these cables meet NFPA 79, Electrical Standard for Industrial Machinery. Other ratings and approvals include Wind Turbine Tray Cable UL Type WTTC, Class 1 Division 2 Hazardous Locations, Submersible Pump, and Direct Burial.

When combined with AutomationDirect ZIPport multi-wire connectors, our flexible multi-conductor cables provide an economical way to organize and simplify control wiring in facilities and during assembly of machinery. These cables are made in the USA and are available in 100 foot, 250 foot, 500 or 1000 foot reels.

Features

- 18 AWG to 10 AWG, 3 to 41 conductors including a ground
- Individual conductors have black PVC/Nylon insulation and are marked with identification numbers
- Rugged PVC outer jacket
- Green/yellow ground wire included
- Multiple ratings and approvals include Type TC-ER (eliminates need for conduit/armor), Type MTW (meets NFPA 79), WTTC, Class 1 Division 2, Submersible Pump, Direct Burial, Wet and Dry Location, Oil Resistant, Sunlight Resistant
- Flexibility for easy installation
- 100 foot, 250 foot, 500 or 1000 foot reels
- Made in the USA
- Ideal for use with ZIPport multi-wire connectors (as shown below)

Cable Use Examples*:

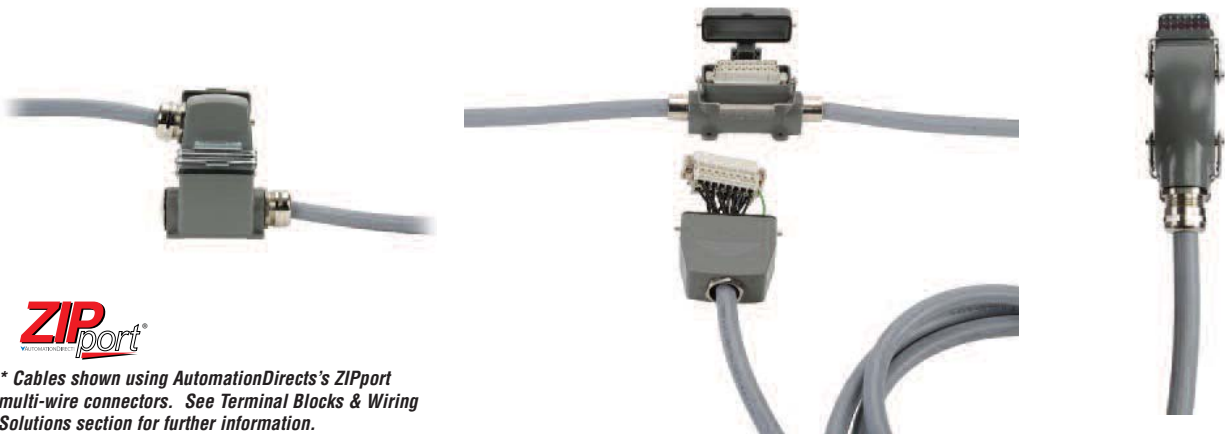

* Cables shown using AutomationDirect's ZIPport multi-wire connectors. See Terminal Blocks & Wiring Solutions section for further information.

18 Gauge Multi-Conductor Flexible Control Cable

| 18 Gauge Multi-Conductor Flexible Control Cable Specifications | | | |
|--|--|-----------------------------|--|
| Conductor Gauge & Stranding | 18 AWG 16/30 bare copper | Flame Rating | FT4, IEEE 1202/383, ICEA T-29-520 |
| Voltage Rating | 600V (Type TC) 1000V (Type WTTC) | Oil Resistance | UL1685, UL MTW NFPA 79 2007 |
| Capacitance | 26 pF/ft Nom. | Applicable Standards | UL Type WTTC UL2277 |
| Resistance | 6.92 Ω D.C. per 1000 FT @ 68°F (20°C) | | UL Type TC UL1277 |
| Impedance | 86 Ω | | c(UL) 600V CIC |
| Operating Temperature | -40°C to 90°C (-40°F to 194°F) | | c(UL) 1000V AWM I/II A/B 600V 90°C (194°F) |
| Jacket Material | Flexible Gray PVC - sunlight & oil resistant | | UL Type TC-ER (Exposed Run) per UL1277 or DP1 (Data Process) |
| Conductor Insulation | 0.015 Inch, PVC + 0.005 Inch, NYLON | | Class 1 Division II per NEC 336, 392, 501 |
| Conductor Markings | "#1-ONE", "2-TWO", "3-THREE", etc... | | UL 83 NEC Type PVC/Nylon conductors |
| Temperature Rating | 75°C (167°F) Wet, 90°C (194°F) Dry | | Direct Burial |
| Cold Bend | -40°C (-40°F) per UL 1277 | | Submersible Pump |
| Cold Impact | -40°C (-40°F) per UL 1277 | | MTW Flexing (meets NFPA 79) |
| Min. Bend Radius | 6x diameter | | ICEA S-73-532 |
| | | | ICEA S-95-658 (NEMA WC-70) |

| 18 Gauge Multi-Conductor Flexible Control Cable | | | | | | | | | | | |
|---|--|------|--------|---|---------------------------------|----------------------------|---------------------------------|------------------|----------------------|-------|-------|
| Part Number | Number of Conductors (includes ground) | AWG | Strand | Overall Conductor Insulation Thickness (Mils) | Overall Jacket Thickness (Mils) | Nominal O.D. (Inches ±10%) | Installed Bend Radius (inches)* | Reel Length (ft) | Approx. Weight (lbs) | Price | |
| V40166-100 | 3 | 18 | 16/30 | 20 | 50 | 0.28 | 1.70 | 100 | 7.8 | <---> | |
| V40166-250 | | | | | | | | 250 | 19.5 | <---> | |
| V40166-1000 | | | | | | | | 1000 | 78.0 | <---> | |
| V40168-100 | 4 | | | | | | 0.31 | 1.84 | 100 | 8.8 | <---> |
| V40168-250 | | | | | | | | | 250 | 22.0 | <---> |
| V40168-1000 | | | | | | | | | 1000 | 88.0 | <---> |
| V40170-100 | 5 | | | | | 0.32 | | 1.91 | 100 | 9.7 | <---> |
| V40170-250 | | | | | | | | | 250 | 24.2 | <---> |
| V40170-1000 | | | | | | | | | 1000 | 97.0 | <---> |
| V40172-100 | 7 | | | | | | 0.36 | 2.13 | 100 | 11.6 | <---> |
| V40172-250 | | | | | | | | | 250 | 29.0 | <---> |
| V40172-1000 | | | | | | | | | 1000 | 116.0 | <---> |
| V40174-100 | 9 | 0.39 | 2.36 | 100 | 13.5 | <---> | | | | | |
| V40174-250 | | | | 250 | 33.8 | <---> | | | | | |
| V40174-1000 | | | | 1000 | 135.0 | <---> | | | | | |
| V40176-100 | 12 | | 0.44 | 2.63 | 100 | 16.3 | <---> | | | | |
| V40176-250 | | | | | 250 | 40.7 | <---> | | | | |
| V40176-1000 | | | | | 1000 | 163.0 | <---> | | | | |
| V40178-100 | 18 | 0.55 | | 3.27 | 100 | 25.1 | <---> | | | | |
| V40178-250 | | | | | 250 | 62.9 | <---> | | | | |
| V40178-1000 | | | | | 1000 | 251.0 | <---> | | | | |
| V40180-100 | 25 | | 0.62 | 3.71 | 100 | 31.5 | <---> | | | | |
| V40180-250 | | | | | 250 | 78.7 | <---> | | | | |
| V40180-1000 | | | | | 1000 | 315.0 | <---> | | | | |

* Installed bend radius = 6x diameter

16 Gauge Multi-Conductor Flexible Control Cable

| 16 Gauge Multi-Conductor Flexible Control Cable Specifications | | | |
|--|--|-----------------------------|--|
| Conductor Gauge & Stranding | 16 AWG 26/30 bare copper | Flame Rating | FT4, IEEE 1202/383, ICEA T-29-520 |
| Voltage Rating | 600V (Type TC) | Oil Resistance | UL1685, UL MTW NFPA 79 2007 |
| | 1000V (Type WTTC) | | Oil Res I & II |
| Capacitance | 29.3 pF/ft Nom. | Applicable Standards | UL Type WTTC UL2277 |
| Resistance | 4.35 Ω D.C. per 1000 FT @ 68°F (20°C) | | UL Type TC UL1277 |
| Impedance | 76 Ω | | c(UL) 600V CIC |
| Operating Temperature | -40°C to 90°C (-40°F to 194°F) | | c(UL) 1000V AWM I/II A/B 600V 90°C (194°F) |
| Jacket Material | Flexible Gray PVC - sunlight & oil resistant | | UL Type TC-ER (Exposed Run) per UL1277 or DP1 (Data Process) |
| Conductor Insulation | 0.015 Inch, PVC + 0.005 Inch, NYLON | | Class 1 Division II per NEC 336, 392, 501 |
| Conductor Markings | "#1-ONE", "2-TWO", "3-THREE", etc... | | UL 83 NEC Type PVC/Nylon conductors |
| Temperature Rating | 75°C (167°F) Wet, 90°C (194°F) Dry | | Direct Burial |
| Cold Bend | -40°C (-40°F) per UL 1277 | | Submersible Pump |
| Cold Impact | -40°C (-40°F) per UL 1277 | | MTW Flexing (meets NFPA 79) |
| Min. Bend Radius | 6x diameter | | ICEA S-73-532 |
| | | ICEA S-95-658 (NEMA WC-70) | |

| 16 Gauge Multi-Conductor Flexible Control Cable | | | | | | | | | | | | | | | | | | | | | | |
|---|--|-----|--------|---|---------------------------------|----------------------------|------------------------|------------------|----------------------|-------|-------|------|-------|-------|-------|------|-------|-------|------|------|-------|-------|
| Part Number | Number of Conductors (includes ground) | AWG | Strand | Overall Conductor Insulation Thickness (Mils) | Overall Jacket Thickness (Mils) | Nominal O.D. (Inches ±10%) | Installed Bend Radius* | Reel Length (ft) | Approx. Weight (lbs) | Price | | | | | | | | | | | | |
| V50196-100 | 3 | 16 | 26/30 | 20 | 50 | 0.31 | 1.84 | 100 | 9.1 | <---> | | | | | | | | | | | | |
| V50196-250 | | | | | | | | 250 | 22.7 | <---> | | | | | | | | | | | | |
| V50196-1000 | | | | | | | | 1000 | 91.0 | <---> | | | | | | | | | | | | |
| V50198-100 | 4 | | | | | 16 | 26/30 | 20 | 50 | 0.33 | 1.98 | 100 | 10.5 | <---> | | | | | | | | |
| V50198-250 | | | | | | | | | | | | 250 | 26.1 | <---> | | | | | | | | |
| V50198-1000 | | | | | | | | | | | | 1000 | 105.0 | <---> | | | | | | | | |
| V50200-100 | 5 | | | | | | | | | 16 | 26/30 | 20 | 50 | 0.34 | 2.06 | 100 | 11.7 | <---> | | | | |
| V50200-250 | | | | | | | | | | | | | | | | 250 | 29.3 | <---> | | | | |
| V50200-1000 | | | | | | | | | | | | | | | | 1000 | 117.0 | <---> | | | | |
| V50202-100 | 7 | | | | | | | | | | | | | 16 | 26/30 | 20 | 50 | 0.39 | 2.31 | 100 | 14.4 | <---> |
| V50202-250 | | | | | | | | | | | | | | | | | | | | 250 | 36.0 | <---> |
| V50202-1000 | | | | | | | | | | | | | | | | | | | | 1000 | 144.0 | <---> |
| V50206-100 | 9 | 16 | 26/30 | 20 | 50 | | | | | | | | | | | | | 0.43 | 2.57 | 100 | 17.1 | <---> |
| V50206-250 | | | | | | | | | | | | | | | | | | | | 250 | 42.7 | <---> |
| V50206-1000 | | | | | | | | | | | | | | | | | | | | 1000 | 171.0 | <---> |
| V50208-100 | 12 | | | | | 16 | 26/30 | 20 | 50 | | | | | | | | | 0.51 | 3.05 | 100 | 24.3 | <---> |
| V50208-250 | | | | | | | | | | | | | | | | | | | | 250 | 60.9 | <---> |
| V50208-1000 | | | | | | | | | | | | | | | | | | | | 1000 | 243.0 | <---> |
| V50212-100 | 18 | | | | | | | | | 16 | 26/30 | 20 | 50 | | | | | 0.59 | 3.56 | 100 | 32.2 | <---> |
| V50212-250 | | | | | | | | | | | | | | | | | | | | 250 | 80.6 | <---> |
| V50212-1000 | | | | | | | | | | | | | | | | | | | | 1000 | 322.0 | <---> |
| V50214-100 | 25 | | | | | | | | | | | | | 16 | 26/30 | 20 | 50 | 0.68 | 4.06 | 100 | 41.2 | <---> |
| V50214-250 | | | | | | | | | | | | | | | | | | | | 250 | 103.0 | <---> |
| V50214-500 | | | | | | | | | | | | | | | | | | | | 500 | 206.0 | <---> |
| V50216-100 | 41 | 16 | 26/30 | 20 | 50 | | | | | | | | | | | | | 0.87 | 5.21 | 100 | 71.2 | <---> |
| V50216-250 | | | | | | | | | | | | | | | | | | | | 250 | 178.0 | <---> |
| V50216-500 | | | | | | | | | | | | | | | | | | | | 500 | 356.0 | <---> |

* Installed bend radius = 6x diameter

14 Gauge Multi-Conductor Flexible Control Cable

| 14 Gauge Multi-Conductor Flexible Control Cable Specifications | | | |
|--|--|-----------------------------|--|
| Conductor Gauge & Stranding | 14 AWG 41/30 bare copper | Flame Rating | FT4, IEEE 1202/383, ICEA T-29-520 |
| Voltage Rating | 600V (Type TC) 1000V (Type WTTTC) | | Oil Resistance |
| Capacitance | 33.6 pF/ft Nom. | Applicable Standards | |
| Resistance | 2.73 Ω D.C. per 1000 FT @ 68°F (20°C) | | UL Type TC UL1277 |
| Impedance | 66 Ω | | c(UL) 600V CIC |
| Operating Temperature | -40°C to 90°C (-40°F to 194°F) | | c(UL) 1000V AWM I/II A/B 600V 90°C (194°F) |
| Jacket Material | Flexible Gray PVC - sunlight & oil resistant | | UL Type TC-ER (Exposed Run) per UL1277 or DP1 (Data Process) |
| Conductor Insulation | 0.015 Inch, PVC + 0.005 Inch, NYLON | | Class 1 Division II per NEC 336, 392, 501 |
| Conductor Markings | "#1-ONE", "2-TWO", "3-THREE", etc... | | UL 83 NEC Type PVC/Nylon conductors |
| Temperature Rating | 75°C (167°F) Wet, 90°C (194°F) Dry | | Direct Burial |
| Cold Bend | -40°C (-40°F) per UL 1277 | | Submersible Pump |
| Cold Impact | -40°C (-40°F) per UL 1277 | | MTW Flexing (meets NFPA 79) |
| Min. Bend Radius | 6x diameter | ICEA S-73-532 | ICEA S-95-658 (NEMA WC-70) |

| 14 Gauge Multi-Conductor Flexible Control Cable | | | | | | | | | | | |
|---|--|------|--------|---|---------------------------------|----------------------------|------------------------|------------------|----------------------|-------|------|
| Part Number | Number of Conductors (includes ground) | AWG | Strand | Overall Conductor Insulation Thickness (Mils) | Overall Jacket Thickness (Mils) | Nominal O.D. (Inches ±10%) | Installed Bend Radius* | Reel Length (ft) | Approx. Weight (lbs) | Price | |
| V60127-100 | 3 | 14 | 41/30 | 20 | 50 | 0.34 | 2.05 | 100 | 11.3 | <--> | |
| V60127-250 | | | | | | | | 250 | 28.1 | <--> | |
| V60127-1000 | | | | | | | | 1000 | 113.0 | <--> | |
| V60129-100 | 4 | | | | | | 0.37 | 2.21 | 100 | 13.3 | <--> |
| V60129-250 | | | | | | | | | 250 | 33.2 | <--> |
| V60129-1000 | | | | | | | | | 1000 | 133.0 | <--> |
| V60131-100 | 5 | | | | | 0.39 | | 2.31 | 100 | 15.1 | <--> |
| V60131-250 | | | | | | | | | 250 | 37.9 | <--> |
| V60131-1000 | | | | | | | | | 1000 | 151.0 | <--> |
| V60133-100 | 7 | | | | | | 0.43 | 2.60 | 100 | 19.1 | <--> |
| V60133-250 | | | | | | | | | 250 | 47.7 | <--> |
| V60133-1000 | | | | | | | | | 1000 | 191.0 | <--> |
| V60135-100 | 9 | | | | | 0.48 | | 2.90 | 100 | 23.0 | <--> |
| V60135-250 | | | | | | | | | 250 | 57.6 | <--> |
| V60135-1000 | | | | | | | | | 1000 | 230.0 | <--> |
| V60137-100 | 12 | | | | | | 0.57 | 3.43 | 100 | 32.4 | <--> |
| V60137-250 | | | | | | | | | 250 | 81.0 | <--> |
| V60137-1000 | | | | | | | | | 1000 | 324.0 | <--> |
| V60139-100 | 18 | 0.67 | 4.03 | 100 | 44.0 | <--> | | | | | |
| V60139-250 | | | | 250 | 110.0 | <--> | | | | | |
| V60139-500 | | | | 500 | 220.0 | <--> | | | | | |
| V60141-100 | 25 | | 0.81 | 4.85 | 100 | 67.2 | <--> | | | | |
| V60141-250 | | | | | 250 | 168.0 | <--> | | | | |
| V60141-500 | | | | | 500 | 336.0 | <--> | | | | |

* Installed bend radius = 6x diameter

12 and 10 Gauge Multi-Conductor Flexible Control Cable

| 12 Gauge Multi-Conductor Flexible Control Cable Specifications | | | |
|--|--|-----------------------------|--|
| Conductor Gauge & Stranding | 12 AWG 65/30 bare copper | Flame Rating | FT4, IEEE 1202/383, ICEA T-29-520 |
| Voltage Rating | 600V (Type TC) 1000V (Type WTTC) | | UL1685, UL MTW NFPA 79 2007 |
| Capacitance | 39.1 pF/ft Nom. | Oil Resistance | Oil Res I & II |
| Resistance | 1.71 Ω D.C. per 1000 FT @ 68°F (20°C) | | UL Type WTTC UL2277 |
| Impedance | 57 Ω | Applicable Standards | UL Type TC UL1277 |
| Operating Temperature | -40°C to 90°C (-40°F to 194°F) | | c(UL) 600V CIC |
| Jacket Material | Flexible Gray PVC - sunlight & oil resistant | | c(UL) 1000V AWM I/II A/B 600V 90°C (194°F) |
| Conductor Insulation | 0.015 Inch, PVC + 0.005 Inch, NYLON | | UL Type TC-ER (Exposed Run) per UL1277 or DP1 (Data Process) |
| Conductor Markings | "#1-ONE", "2-TWO", "3-THREE", etc... | | Class 1 Division II per NEC 336, 392, 501 |
| Temperature Rating | 75°C (167°F) Wet, 90°C (194°F) Dry | | UL 83 NEC Type PVC/Nylon conductors |
| Cold Bend | -40°C (-40°F) per UL 1277 | | Direct Burial |
| Cold Impact | -40°C (-40°F) per UL 1277 | | Submersible Pump |
| Min. Bend Radius | 6x diameter | | MTW Flexing (meets NFPA 79) |
| | | | ICEA S-73-532 |
| | | | ICEA S-95-658 (NEMA WC-70) |

| 12 Gauge Multi-Conductor Flexible Control Cable | | | | | | | | | | |
|---|--|-----|--------|---|---------------------------------|----------------------------|------------------------|------------------|----------------------|-------|
| Part Number | Number of Conductors (includes ground) | AWG | Strand | Overall Conductor Insulation Thickness (Mils) | Overall Jacket Thickness (Mils) | Nominal O.D. (Inches ±10%) | Installed Bend Radius* | Reel Length (ft) | Approx. Weight (lbs) | Price |
| V70107-100 | 4 | 12 | 65/30 | 20 | 50 | 0.43 | 2.57 | 100 | 17.4 | <--> |
| V70107-250 | | | | | | | | 250 | 43.5 | <--> |
| V70107-1000 | | | | | | | | 1000 | 174 | <--> |

* Installed bend radius = 6x diameter

| 10 Gauge Multi-Conductor Flexible Control Cable Specifications | | | |
|--|--|-----------------------------|--|
| Conductor Gauge & Stranding | 10 AWG 105/30 bare copper | Flame Rating | FT4, IEEE 1202/383, ICEA T-29-520 |
| Voltage Rating | 600V (Type TC) 1000V (Type WTTC) | | UL1685, UL MTW NFPA 79 2007 |
| Capacitance | 38.8 pF/ft Nom. | Oil Resistance | Oil Res I & II |
| Resistance | 1.08 Ω D.C. per 1000 FT @ 68°F (20°C) | | UL Type WTTC UL2277 |
| Impedance | 57 Ω | Applicable Standards | UL Type TC UL1277 |
| Operating Temperature | -40°C to 90°C (-40°F to 194°F) | | c(UL) 600V CIC |
| Jacket Material | Flexible Gray PVC - sunlight & oil resistant | | c(UL) 1000V AWM I/II A/B 600V 90°C (194°F) |
| Conductor Insulation | 0.020 Inch, PVC + 0.005 Inch, NYLON | | UL Type TC-ER (Exposed Run) per UL1277 or DP1 (Data Process) |
| Conductor Markings | "#1-ONE", "2-TWO", "3-THREE", etc... | | Class 1 Division II per NEC 336, 392, 501 |
| Temperature Rating | 75°C (167°F) Wet, 90°C (194°F) Dry | | UL 83 NEC Type PVC/Nylon conductors |
| Cold Bend | -40°C (-40°F) per UL 1277 | | Direct Burial |
| Cold Impact | -40°C (-40°F) per UL 1277 | | Submersible Pump |
| Min. Bend Radius | 6x diameter | | MTW Flexing (meets NFPA 79) |
| | | | ICEA S-73-532 |
| | | | ICEA S-95-658 (NEMA WC-70) |

| 10 Gauge Multi-Conductor Flexible Control Cable | | | | | | | | | | |
|---|--|-----|--------|---|---------------------------------|----------------------------|------------------------|------------------|----------------------|-------|
| Part Number | Number of Conductors (includes ground) | AWG | Strand | Overall Conductor Insulation Thickness (Mils) | Overall Jacket Thickness (Mils) | Nominal O.D. (Inches ±10%) | Installed Bend Radius* | Reel Length (ft) | Approx. Weight (lbs) | Price |
| V80059-100 | 4 | 10 | 105/30 | 25 | 50 | 0.50 | 3.02 | 100 | 27.8 | <--> |
| V80059-250 | | | | | | | | 250 | 69.5 | <--> |
| V80059-1000 | | | | | | | | 1000 | 278.0 | <--> |

* Installed bend radius = 6x diameter

www.automationdirect.com

More than just a great online store

In addition to our printed catalog, we have an online network of information available 24/7.

FREE videos, FREE software, FREE documentation, FREE support, FREE magazine . . .

. . . well you get the point. :-)

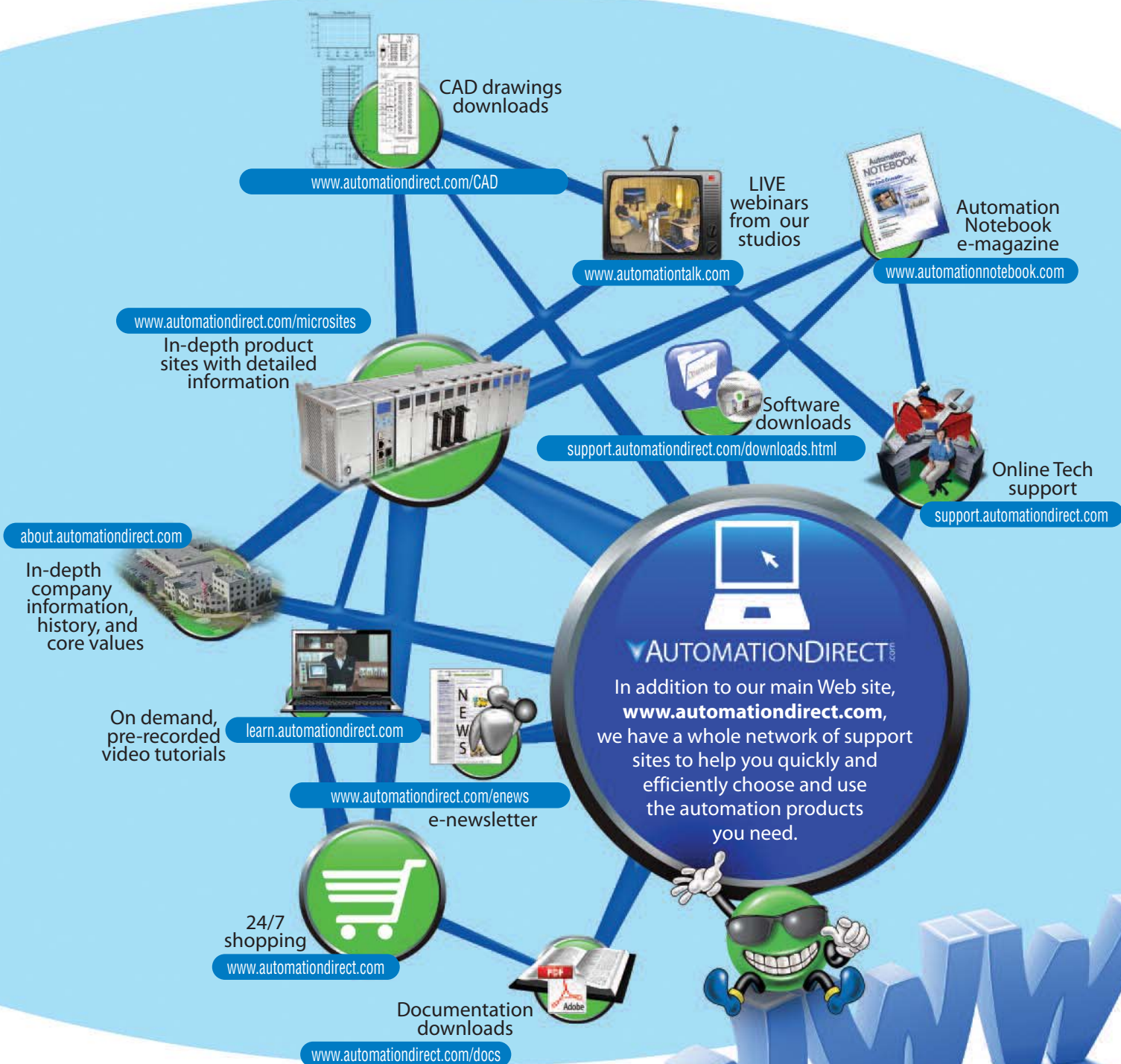

**“Very, very thorough site;
one of the best industrial sites we’ve reviewed”**
IEN magazine March 2009



RS-232/422 and RS-485 Data Cables

Industrial Use Data Cables

Electrically radiated noise frequently present in factory floor environments can interfere with device-to-device communication circuits, causing delayed signals or data loss. One important factor in establishing a good, reliable communication circuit is cable selection. AutomationDirect offers high quality, low-capacitance data cables designed with impedances specific for RS-232/422 and RS-485 communication applications in industrial environments. The 24 AWG tinned copper conductors are twisted pairs to reduce electrical noise sensitivity and are available in one, two, or three-pair color coded constructions. The polyethylene conductor insulation provides a very high insulation resistance with a low, stable dielectric constant resulting in lower capacitance and excellent velocity of propagation for superior signal transmission.

To protect from radiated or conducted electromagnetic interference (EMI), our data cables have combination shields consisting of an overall foil shield layer with drain wire and a woven braid shield layer. The overall foil shield has 100% cable coverage for excellent protection against higher frequency noise. A drain wire is provided to easily terminate and ground the foil shield. A second shield layer consists of a woven braid that is ideal for minimizing low frequency interference while providing superior structural integrity to the overall cable. Our combination foil/braid shielded cables offer maximum shield effectiveness across the frequency spectrum compared to other single layer shielded cables. The rugged gray PVC jacket is durable enough for use in demanding industrial applications.



Features

- Low capacitance data cables for RS-232, RS-422, and RS-485 applications in industrial environments
- Color coded 24 AWG tinned copper twisted pair conductors to reduce electrical noise sensitivity
- Polyethylene insulation provides a very high insulation resistance with a low, stable dielectric constant
- Combination overall foil shield with tinned copper drain wire plus tinned copper braid shield maximizes shielding effectiveness compared to single layer shielded cables
- Rugged gray PVC jacket provides durability in demanding installations
- UL CM/CL2 or AWM Style 2919

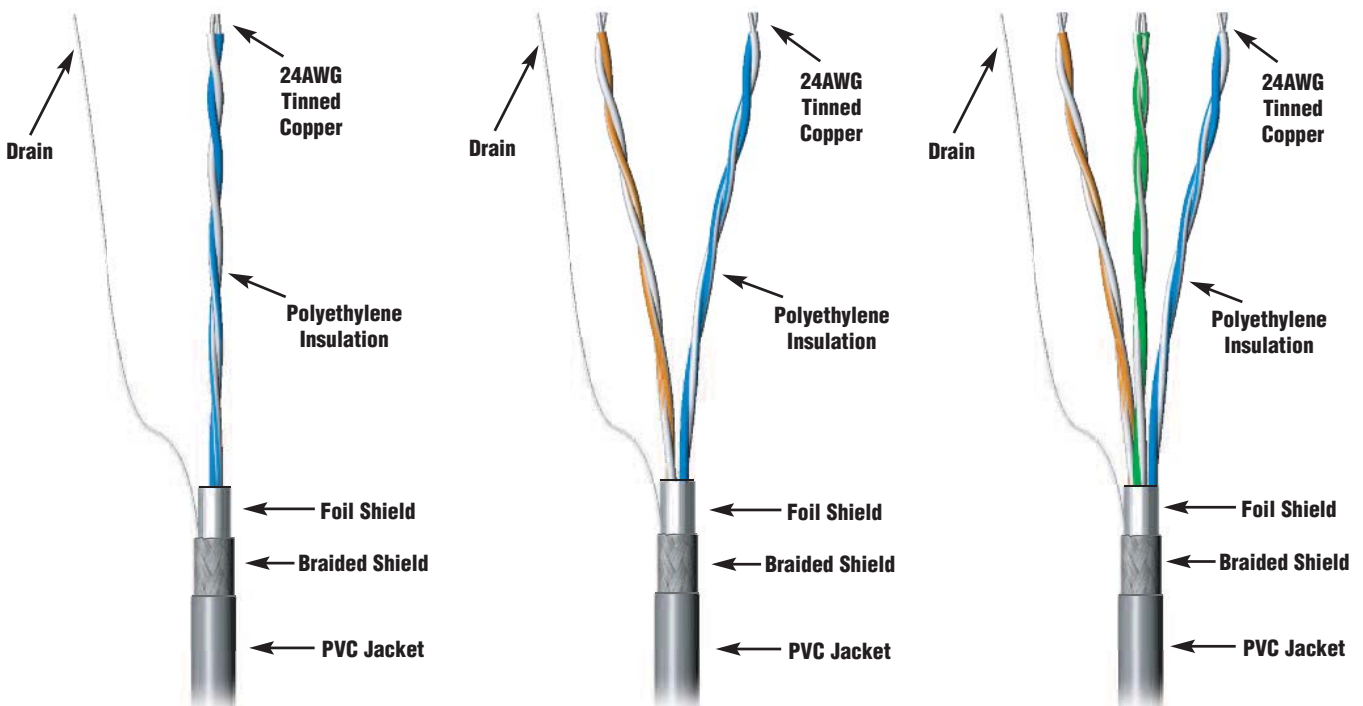

RS-485 Data Cable Specifications

| RS-485 Data Cables | | | | |
|--------------------------------|---------------|--|---|---|
| | | L19827 Series | L19954 Series | L19773 Series |
| Construction | | 24 AWG 7-strand tinned copper; 1 twisted pair; overall foil and tinned copper braid shielding; PVC jacket. AWM Style 2919; EIA-485; CM/CL2 | 24 AWG 7-strand tinned copper; 2 twisted pairs; overall foil and tinned copper braid shielding; PVC jacket. AWM Style 2919; EIA-485; CM/CL2 | 24 AWG 7-strand tinned copper; 3 twisted pairs; overall foil and tinned copper braid shielding; PVC jacket. AWM Style 2919; EIA-485; CM/CL2 |
| Insulation | | Polyethylene | Polyethylene | Polyethylene |
| Color Code | Pair 1 | White/Blue Line & Blue/White Line | White/Blue Line & Blue/White Line | White/Blue Line & Blue/White Line |
| | Pair 2 | N/A | White/Orange Line & Orange/White Line | White/Orange Line & Orange/White Line |
| | Pair 3 | N/A | N/A | White/Green Line & Green/White Line |
| Assembly | | 1 Twisted pair, overall shield | 2 Twisted pairs cabled; overall foil tape shield and 95% Tc braid, jacketed | 3 Twisted pairs cabled; overall foil tape shield and 95% Tc braid, jacketed |
| Pair Twist | | 2.8" Lay (4.3 Twists per foot) | 1" Lay (12 twists/foot)/cabling 2.5" lay (4.8 twists/foot) | 1" Lay (12 twists/foot)/cabling 2.5" lay (4.8 twists/foot) |
| Shield/Drain | | Overall foil shield & 24 AWG strand tinned copper drain wire, plus 95% tinned copper braid | Overall foil shield & 24 AWG strand tinned copper drain wire, plus 95% tinned copper braid | Overall foil shield & 24 AWG strand tinned copper drain wire, plus 95% tinned copper braid |
| Jacket | | Chrome Gray PVC | Chrome Gray PVC | Gray PVC |
| Diameter | | 0.236" Nominal | 0.353" Nominal | 0.380" Nominal |
| Minimum Bend Radius | | 2.5" (Install) | 3.6" (Install) | 3.8" (Install) |
| Cable Weight | | 34.4 lb/1000' Approx. | 57.9 lb/1000' Approx. | 64.6 lb/1000' Approx. |
| Impedance | | 120Ω | 120Ω | 120Ω |
| Capacitance | | 12.8 pF/ft Nom. | 12.8 pF/ft Nom. | 12.8 pF/ft Nom. |
| Resistance | | 27.2Ω DC per 1000 ft @ 20°C (68°F) max | 27.2Ω DC per 1000 ft @ 20°C (68°F) max | 27.2Ω DC per 1000 ft @ 20°C (68°F) max |
| Attenuation | | 0.6 dB/100 ft @ 1 MHz (Nominal) | 0.6 dB/100 ft @ 1 MHz (Nominal) | 0.6 dB/100 ft @ 1 MHz (Nominal) |
| Velocity of Propagation | | 66.2% | 66.2% | 66.2% |
| Max. Current | | 2.1 Amps per conductor @ 25°C (77°F) (Maximum recommended) | 2.1 Amps per conductor @ 25°C (77°F) (Maximum recommended) | 1.54 Amps per conductor @ 25°C (77°F) (Maximum recommended) |
| Temp/Voltage | | 80°C (176°F)/30V (AWM 2919) or 60°C (140°F)/300V (UL CM) | 80°C (176°F)/30V (AWM 2919) or 60°C (140°F)/300V (UL CM) | 80°C (176°F)/30V (AWM 2919) or 60°C (140°F)/300V (UL CM) |
| Plenum | | No | No | No |
| Spool/Coil Length | | 100, 500 or 1000 feet | 100, 500 or 1000 feet | 100, 500 or 1000 feet |
| UL Classification | | CM/CL2 or AWM Style 2919 | CM/CL2 or AWM Style 2919 | CM/CL2 or AWM Style 2919 |
| Agency Approvals | | UL (E118871), RoHS & REACH Compliant | UL (E118871), RoHS & REACH Compliant | UL (E118871), RoHS & REACH Compliant |

Illustration Examples



Single Twisted Pair



2 Twisted Pairs



3 Twisted Pairs

RS-232/422 Data Cable Specifications

| RS-232/422 Data Cables | | | |
|--------------------------------|---------------|---|---|
| | | L19772 Series | L19853 Series |
| Construction | | 24 AWG 7-strand tinned copper; 2 twisted pairs; cabled; overall foil and 65% tinned copper braid shield, PVC jacket | 24 AWG 7-strand tinned copper; 3 twisted pairs; cabled; overall foil and 65% tinned copper braid shield, PVC jacket |
| Insulation | | Foam polyethylene | Foam polyethylene |
| Color Code | Pair 1 | White/Blue Line & Blue/White Line | White/Blue Line & Blue/White Line |
| | Pair 2 | White/Orange Line & Orange/White Line | White/Orange Line & Orange/White Line |
| | Pair 3 | N/A | White/Green Line & Green/White Line |
| Assembly | | 2 Twisted pairs cabled; overall foil tape shield and 65% tinned copper braid, jacketed | 3 Twisted pairs cabled; overall foil tape shield and 65% tinned copper braid, jacketed |
| Pair Twist | | 1" Lay (12 twists/foot)/cabling 2.0" lay (6 twists/foot) | 1" Lay (12 twists/foot)/cabling 2.0" lay (6 twists/foot) |
| Shield/Drain | | Overall foil shield & 24 AWG strand tinned copper drain wire plus 65% tinned copper braid | Overall foil shield, & 24 AWG strand tinned copper drain wire plus 65% tinned copper braid |
| Jacket | | Gray PVC | Gray PVC |
| Diameter | | 0.266" Nominal | 0.291" Nominal |
| Min. Bend | | 2.75" (Install) | 3.0" (Install) |
| Cable Wt | | 34.2 lb/1000' Approx. | 43.3 lb/1000' Approx. |
| Impedance | | 100Ω | 100Ω |
| Capacitance | | 12.5 pF/ft Nom. | 12.5 pF/ft Nom. |
| Resistance | | 27.2Ω DC per 1000 ft @ 20°C (68°F) max | 27.2Ω DC per 1000 ft @ 20°C (68°F) max |
| Attenuation | | 0.6 dB/100 ft @ 1 MHz | 0.6 dB/100 ft @ 1 MHz |
| Velocity of Propagation | | 79.1% | 79.1% |
| Max. Current | | 1.5 Amps per conductor @ 25°C (77°F) (Maximum recommended) | 1.5 Amps per conductor @ 25°C (77°F) (Maximum recommended) |
| Temp/Voltage | | 80°C (176°F)/30V (AWM 2919) or 60°C (140°F)/300V (UL CM) | 80°C (176°F)/30V (AWM 2919) or 60°C (140°F)/300V (UL CM) |
| Plenum | | No | No |
| Spool/Coil Length | | 100, 500 or 1000 feet | 100, 500 or 1000 feet |
| UL Classification | | CM/CL2 or AWM Style 2919 | CM/CL2 or AWM Style 2919 |
| Agency Approvals | | UL (E118871), RoHS & REACH Compliant | UL (E118871), RoHS & REACH Compliant |

Illustration Examples

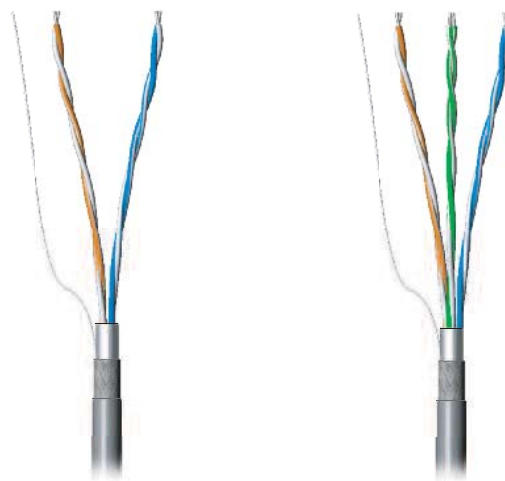

2 Twisted Pairs

3 Twisted Pairs

RS-232/422 and RS-485 Data Cables Selection

| Data Cables | | | | | | | |
|-------------|-----------------|------------------|--------------|--|---|--------------|-------|
| Part Number | Wiring Standard | Length | No. of Pairs | Pair Colors | Description | Weight (lbs) | Price |
| L19827-100 | RS-485 | 100 ft (30.5m) | 1 | Pair 1 - White/Blue Line & Blue/White Line Pair 2 - N/A Pair 3 - N/A | RS-485 cable, multi-conductor low capacitance, 120Ω impedance data cable, 1 twisted pair, 24 AWG conductors with polyethylene insulation, overall foil shield and tinned copper braid shield with 24 AWG tinned copper drain wire, chrome gray PVC jacket, UL cable type CM/CL2 and AWM style 2919 | 4 | <---> |
| L19827-500 | | 500 ft (152.4m) | | | | 18 | <---> |
| L19827-1000 | | 1000 ft (304.8m) | | | | 35 | <---> |
| L19954-100 | RS-485 | 100 ft (30.5m) | 2 | Pair 1 - White/Blue Line & Blue/White Line Pair 2 - White/Orange Line & Orange/White Line Pair 3 - N/A | RS-485 cable, multi-conductor low capacitance, 120Ω impedance data cable, 2 twisted pairs, 24 AWG conductors with polyethylene insulation, overall foil shield and tinned copper braid shield with 24 AWG tinned copper drain wire, chrome gray PVC jacket, UL cable type CM/CL2 and AWM style 2919 | 7 | <---> |
| L19954-500 | | 500 ft (152.4m) | | | | 37 | <---> |
| L19954-1000 | | 1000 ft (304.8m) | | | | 66 | <---> |
| L19773-100 | RS-485 | 100ft (30.5m) | 3 | Pair 1 - White/Blue Line & Blue/White Line Pair 2 - White/Orange Line & Orange/White Line Pair 3 - White/Green Line & Green/White Line | RS-485 cable, multi-conductor low capacitance, 120Ω impedance data cable, 3 twisted pairs, 24 AWG conductors with polyethylene insulation, overall foil shield and tinned copper braid shield with 24 AWG tinned copper drain wire, chrome gray PVC jacket, UL cable type CM/CL2 and AWM style 2919 | 7 | <---> |
| L19773-500 | | 500 ft (152.4m) | | | | 37 | <---> |
| L19773-1000 | | 1000 ft (304.8m) | | | | 64 | <---> |
| L19772-100 | RS-232 & RS-422 | 100 ft (30.5m) | 2 | Pair 1 - White/Blue Line & Blue/White Line Pair 2 - White/Orange Line & Orange/White Line Pair 3 - N/A | RS-422/RS-232 cable, multi-conductor low capacitance, 100Ω impedance data cable, 2 twisted pairs, 24 AWG conductors with foam polyethylene insulation, overall foil shield and tinned copper braid shield with 24 AWG tinned copper drain wire, chrome gray PVC jacket, UL cable type CM/CL2 and AWM style 2919 | 4 | <---> |
| L19772-500 | | 500 ft (152.4m) | | | | 21 | <---> |
| L19772-1000 | | 1000 ft (304.8m) | | | | 38 | <---> |
| L19853-100 | RS-232 & RS-422 | 100 ft (30.5m) | 3 | Pair 1 - White/Blue Line & Blue/White Line Pair 2 - White/Orange Line & Orange/White Line Pair 3 - White/Green Line & Green/White Line | RS-422/RS-232 cable, multi-conductor low capacitance, 100Ω impedance data cable, 3 twisted pairs, 24 AWG conductors with foam polyethylene insulation, overall foil shield and tinned copper braid shield with 24 AWG tinned copper drain wire, chrome gray PVC jacket, UL cable type CM/CL2 and AWM style 2919 | 5 | <---> |
| L19853-500 | | 500 ft (152.4m) | | | | 23 | <---> |
| L19853-1000 | | 1000 ft (304.8m) | | | | 41 | <---> |

| Data Cables Cross Reference | | | | | | |
|-----------------------------|--------------|--------------------|--------------------|---------------------|-------------|-------------|
| ADC Part # | Belden Cable | Alpha Wire & Cable | Carol Wire & Cable | Allied Wire & Cable | Provo Cable | Delco Cable |
| L19772-xxxx | 8102 / 9729 | 6222C | C0515A | 1030 | 5402 | 30702 |
| L19853-xxxx | 8103 | 6223C | C0516A | 1032 | 5403 | 30702 |
| L19827-xxxx | 9841 | 6412 | C0841A | 9682 | 5401 | 43901 |
| L19954-xxxx | 9842 | 6413 | C0842A | 9684 | 5402 | 43902 |
| L19773-xxxx | 9843 | 6414 | C0843A | 9686 | 5404 | 43903 |

Bryant® Wire Management Products

Cord Grips Family Overview

Strain Relief Grips

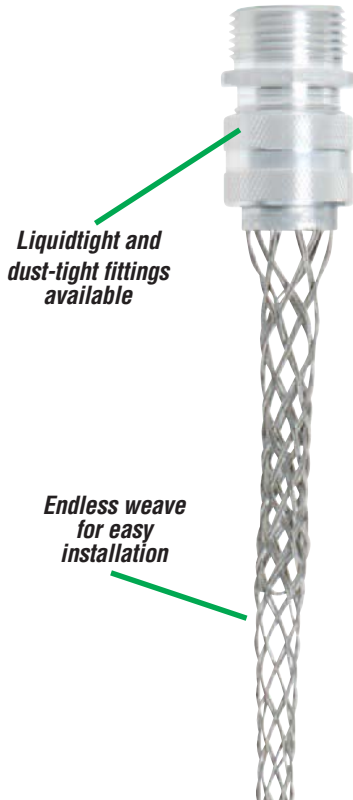

Strain Relief Grips are used to connect cable enclosures and industrial equipment. These grips prevent cable pullout at the point of termination due to tension, vibration, flexure or motion. Used in conjunction with bus drop support grips and safety springs, they are an integral part of an overall support and strain relief system. These grips are suitable for indoor or outdoor use where subject to moisture, splash or washdown. Examples are crane hoist and pendant drop stations, hand tools, pumps, and processing equipment.

Deluxe Cord Strain Relief Grips

- Endless weave for easy installation
- Indoor and outdoor applications
- Provides arc-of-bend control
- Stainless steel mesh
- Corrosion resistant
- Liquid-tight and dust-tight
- Range 0.187" – 1.687"

Dust-tight Strain Relief Grips

- Dust-tight
- Galvanized steel mesh
- For indoor applications only
- Ideal for use in bus drop systems, motor connections, panel boards, and internal wiring of machines
- Range 0.32" – 1.70"

Support Grips



Support Grips are applied to the vertical or horizontal runs of cable or service lines to support dead weight and reduce potential damage due to breakage or stress. These grips are designed to be used indoors for cable support where flexible cable connects electrical equipment to bus duct. Applications also include support for air hoses and water hoses.

Standard Duty Support Grips

- Single U eye closed mesh fits over cable end
- Indoor and outdoor applications
- Split mesh is used when cable end is inaccessible
- Strand equalizers reinforce gripping strength and position; distributes load equally
- Range 0.54" – 1.74"

Bus Drop Support Grips

- Light duty
- Strand equalizers position wires for equal loading
- Single variable weave
- Indoor use only
- Range 0.24" – 1.25"

BRYANT®

Bryant[®] Wire Management Products

Cord Grips Family Overview - Continued

Pulling Grips

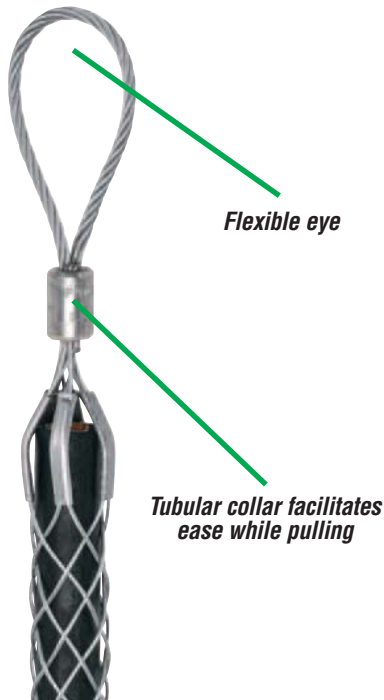

Pulling Grips are designed to serve as reusable tools for light industrial pulling of electrical cable and for underground and industrial plant wiring and re-wiring. These grips offer protection from abrasion and ease the cable through bends and rough surfaces. They also serve as a temporary splice, when replacing old cable with new, and to pull slack in new construction or maintenance operations.

Light Duty Low Tension Pulling Grips

- Ideal for use in utility work, industrial and commercial building service lines, underground transmission line stringing
- Range 0.75" – 1.74"

Junior Low Tension Pulling Grips

- Ideal for use in utility work, industrial and commercial building service lines, underground transmission line stringing
- Range 0.25" – 1.24"

BRYANT[®]

Deluxe Cord Strain Relief Grips

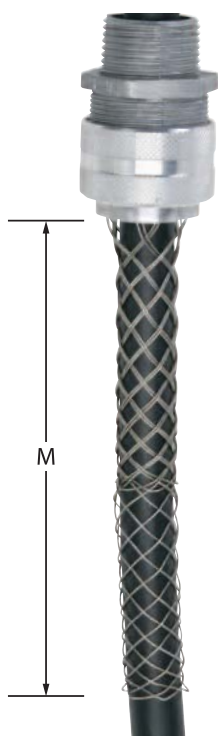

M = Mesh Length

Features

- Double to single weave variable mesh
- Stainless steel mesh offers corrosion resistance and adds strength
- Neoprene oil and watertight seal
- Liquidtight and dust-tight seal
- Aluminum fitting
- Mesh flexibility for easy installation
- Lock nuts and bushing not included

BRYANT®

Applications

- Food processing equipment
- Chemical machinery
- Switch boxes
- Pumps
- Compressors
- Motors & machine tool shops
- Drop stations
- Heavy-duty applications
- Indoor/outdoor applications

Agency Approvals

- UL Listed File E167220
- Type 1, 4, 4X, 6, 6P, 3, 3X, 3S, 3SX, 5, 12K or 13
- CSA Certified File LR701228



| Bryant® Deluxe Strain Relief Cord Grips, Straight Male Thread | | | | | |
|---|----------------------------------|-----------------|--------------------------|---------------|-------|
| Part Number | Grip Diameter Range Inches (cm.) | Trade Size NPT* | Mesh Length Inches (cm.) | Weight (lbs.) | Price |
| DC1812 | 0.187-0.250 (0.47-0.63) | ½ in. | 2.44 (6.20) | 0.1 | <---> |
| DC2512 | 0.250-0.375 (0.63-0.95) | ½ in. | 3.91 (9.93) | 0.1 | <---> |
| DC3712 | 0.375-0.500 (0.95-1.27) | ½ in. | 4.44 (11.28) | 0.1 | <---> |
| DC5012 | 0.500-0.625 (1.27-1.59) | ½ in. | 4.71 (11.96) | 0.1 | <---> |
| DC5034 | 0.500-0.625 (1.27-1.59) | ¾ in. | 4.71 (11.96) | 0.1 | <---> |
| DC6234 | 0.625-0.750 (1.59-1.90) | ¾ in. | 6.31 (16.03) | 0.1 | <---> |
| DC621 | 0.625-0.750 (1.59-1.90) | 1 in. | 6.11 (15.52) | 0.1 | <---> |
| DC751 | 0.750-0.875 (1.90-2.22) | 1 in. | 6.31 (16.03) | 0.3 | <---> |
| DC871 | 0.875-1.000 (2.22-2.54) | 1 in. | 6.51 (16.54) | 0.3 | <---> |
| DC100114 | 1.000-1.125 (2.54-2.86) | 1¼ in. | 6.16 (15.65) | 0.5 | <---> |
| DC112114 | 1.125-1.250 (2.86-3.17) | 1¼ in. | 6.04 (15.34) | 0.5 | <---> |
| DC125112 | 1.250-1.375 (3.17-3.49) | 1½ in. | 7.66 (19.46) | 0.6 | <---> |
| DC131112 | 1.312-1.437 (3.33-3.65) | 1½ in. | 8.11 (20.60) | 1.0 | <---> |
| DC1562 | 1.562-1.687 (3.97-4.28) | 2 in. | 10.00 (25.40) | 1.0 | <---> |

Note: NPT = National Pipe Taper

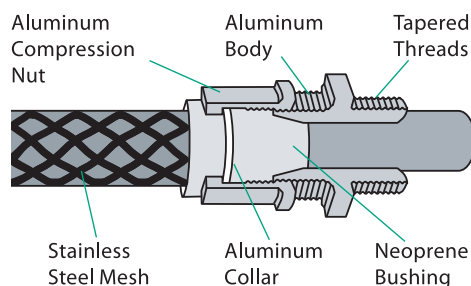

Dust-tight Strain Relief Grips - Wide Range

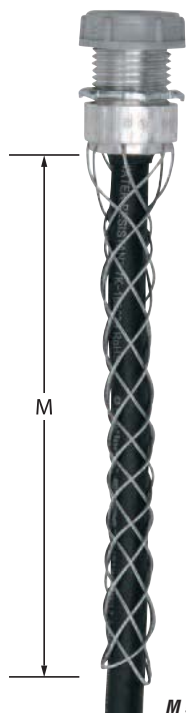

M = Mesh Length

Features

- Single weave variable mesh
- Galvanized steel mesh for additional holding power in abrasive environments
- Insulating bushing
- One-piece design
- Dust-tight seal
- Easily installed
- Steel locknut and threaded fitting
- Lock nuts and bushing included

BRYANT®

Applications

- Bus drop systems
- Motor boxes
- Power boxes
- Internal wiring of machines and cabinets
- Light to moderate duty applications
- Indoor use only
- Controlling arc-of-bend

Agency Approvals

- UL Listed File E167220
- Type 1, 3, 3X, 3S, 3SX, 5, 12K or 13
- CSA Certified File LR701228



| Bryant® Wide Range Strain Relief Grips | | | | | | |
|--|----------------------------------|---------------------|-------------------------|--|---------------|-------|
| Part Number | Cable Diameter Range Inches (cm) | Trade Size NPS/NPT* | Mesh Length Inches (cm) | Knockout Hole Recommended Min. to Max. Inches (cm) | Weight (lbs.) | Price |
| BDSR32 | 0.32-0.43 (0.81-1.09) | ½" NPS | 3.75 (9.52) | 0.86-0.91 (21.8-23.0) | 0.1 | <---> |
| BDSR43 | 0.43-0.54 (1.09-1.37) | ½" NPS | 4.75 (12.06) | 0.86-0.91 (21.8-23.0) | 0.1 | <---> |
| BDSR54 | 0.54-0.73 (1.37-1.85) | ¾" NPS | 6.50 (16.51) | 1.09-1.14 (27.8-29.0) | 0.1 | <---> |
| BDSR73 | 0.73-0.97 (1.85-2.46) | 1" NPS | 7.00 (17.78) | 1.36-1.41 (34.5-35.7) | 0.2 | <---> |
| BDSR97 | 0.97-1.25 (2.46-3.17) | 1¼" NPS | 9.00 (22.86) | 1.72-1.77 (43.7-44.9) | 0.3 | <---> |
| BDSR125 | 1.25-1.50 (3.17-3.81) | 1½" NPT | 11.75 (29.84) | 1.97-2.02 (50.0-51.2) | 0.4 | <---> |
| BDSR150 | 1.50-1.70 (3.81-4.32) | 2" NPT | 13.25 (33.65) | 2.45-2.50 (62.3-63.5) | 0.5 | <---> |

Note: NPS = National Pipe Straight
NPT = National Pipe Taper

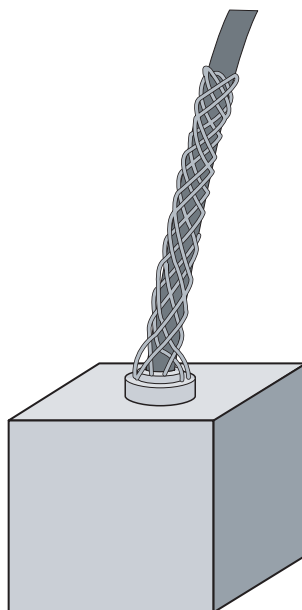

Standard Duty Support Grips - Closed Mesh

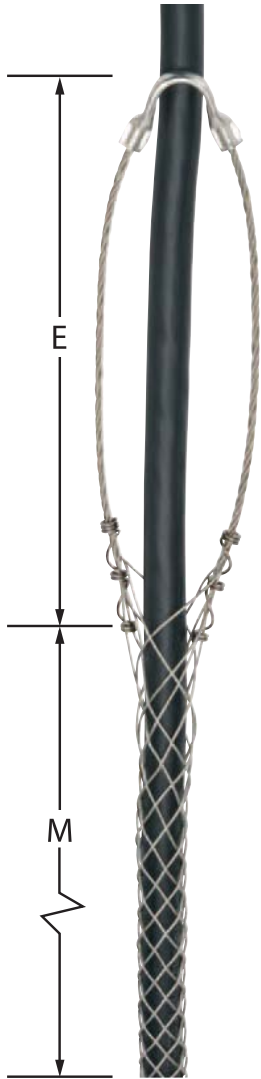

Features

- Closed grips with U eye
- Single weave variable mesh
- Tin-coated bronze grips are non-magnetic minimizing hysteresis and resultant heat build-up which can lead to cable degradation and reduced life
- Uniform gripping power
- Endless weave
- Strand equalizers position wires for equal loading

Applications

- Commercial towers
- Elevator shafts
- Buildings
- Utility poles - telephone and power
- Construction
- Factories

Agency Approvals

- CSA Certified File LR701228



BRYANT®

| Bryant® Single Eye, Closed Mesh Support Grips | | | | | | |
|---|----------------------------------|--|------------------------|-------------------------|---------------|-------|
| Part Number | Cable Diameter Range Inches (cm) | Approximate Breaking Strength Pounds (Newtons) | Eye Length Inches (cm) | Mesh Length Inches (cm) | Weight (lbs.) | Price |
| SPC050U | 0.50-0.62 (1.27-1.57) | 530 (2,357) | 7.0 (17.78) | 10.0 (25.40) | 0.1 | <--> |
| SPC062U | 0.63-0.74 (1.60-1.88) | 790 (3,514) | 8.0 (20.32) | 10.0 (25.40) | 0.2 | <--> |
| SPC075U | 0.75-0.99 (1.90-2.51) | 1,020 (4,537) | 8.0 (20.32) | 13.0 (33.02) | 0.2 | <--> |
| SPC100U | 1.00-1.24 (2.54-3.15) | 1,610 (7,161) | 9.0 (22.86) | 14.0 (35.56) | 0.3 | <--> |
| SPC125U | 1.25-1.49 (3.17-3.78) | 1,610 (7,161) | 10.0 (25.40) | 15.0 (38.10) | 0.4 | <--> |
| SPC150U | 1.50-1.74 (3.81-4.42) | 1,610 (7,161) | 12.0 (30.48) | 17.0 (43.18) | 0.4 | <--> |

E = Eye Length

M = Mesh Length

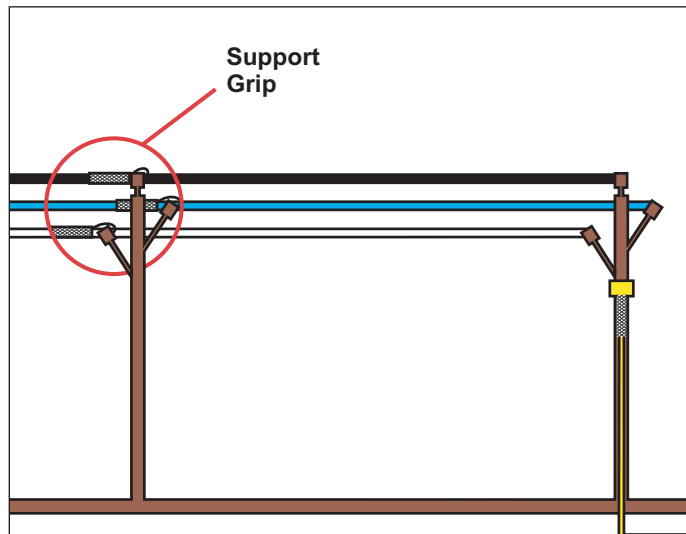

CAUTION: Never use grip to approximate breaking strength. Refer to technical data page for safety and working load factors. Banding is necessary to guard against accidental release of grip and provide maximum reliability.

Bus Drop Support Grips

Features

- Single variable weave
- Galvanized steel for additional holding power in abrasive environments
- Strand equalizers position wires for equal loading
- Light-duty support
- Indoor only, permanent support
- Easily installed
- Single eye

Applications

- All factory equipment
- Cable drops for electrical connections

Agency Approvals

- UL Listed File E167220
- CSA Certified File LR701228



BRYANT®



BDS56U

E = Eye Length

M = Mesh Length

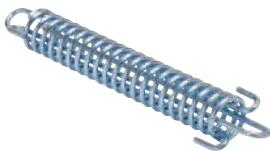

S80

| Bryant® Single Eye, Closed Mesh Bus Drop Support Grips | | | | | | |
|--|----------------------------------|--|------------------------|-------------------------|---------------|-------|
| Part Number | Cable Diameter Range Inches (cm) | Approximate Breaking Strength Pounds (Newtons) | Eye Length Inches (cm) | Mesh Length Inches (cm) | Weight (lbs.) | Price |
| BDS24U | 0.24-0.32 (0.61-0.81) | 350 (1,557) | 3.0 (7.62) | 3.50 (8.89) | 0.1 | <---> |
| BDS32U | 0.32-0.43 (0.81-1.09) | 450 (2,002) | 4.0 (10.16) | 4.00 (10.16) | 0.1 | <---> |
| BDS43U | 0.43-0.56 (1.09-1.42) | 550 (2,446) | 6.0 (15.24) | 4.75 (12.06) | 0.1 | <---> |
| BDS56U | 0.56-0.73 (1.42-1.85) | 1,000 (4,448) | 7.0 (17.78) | 6.00 (15.24) | 0.1 | <---> |
| BDS73U | 0.73-0.85 (1.85-2.16) | 1,400 (6,227) | 7.0 (17.78) | 6.75 (17.14) | 0.1 | <---> |
| BDS85U | 0.85-1.00 (2.16-2.54) | 1,400 (6,227) | 8.0 (20.32) | 8.00 (20.32) | 0.1 | <---> |
| BDS100U | 1.00-1.25 (2.54-3.17) | 1,500 (6,672) | 9.0 (22.86) | 9.50 (24.13) | 0.2 | <---> |

| Bus Drop Safety Springs | | | | | | |
|-------------------------|----------------------|--|--------------------|---|---------------|-------|
| Part Number | Diameter Inches (cm) | Approximate Breaking Strength Pounds (Newtons) | Length Inches (cm) | Maximum Deflection | Weight (lbs.) | Price |
| S40 | 0.75 (1.90) | 500 (2,224) | 8.25 (20.95) | 2 3/4 in. at 40 lbs. (6.67 cm at 178 N) | 0.2 | <---> |
| S80 | 1.00 (2.54) | 850 (3,781) | 8.25 (20.95) | 3 1/8 in. at 80 lbs. (7.94 cm at 356 N) | 0.4 | <---> |

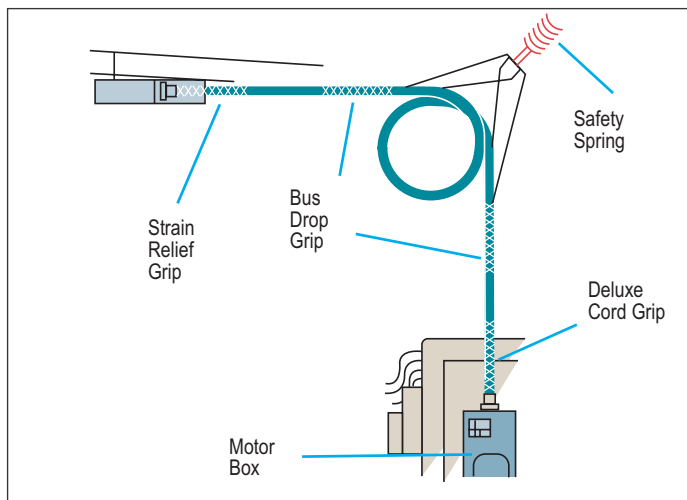

CAUTION: Never use grip to approximate breaking strength. Refer to technical data page for safety and working load factors. Banding is necessary to guard against accidental release of grip and provide maximum reliability.

Light Duty Low Tension Pulling Grips



PA150

Features

- Flexible eye
- Single weave variable mesh provides uniform positive gripping power
- High strength galvanized steel
- Reusable
- Easily mates with swivel and link type connections
- Tubular metal shoulders protect cable ends
- Easily installed on cable

Applications

- Utility work
- Service lines in industrial and commercial buildings
- Light-duty underground transmission lines stringing

Agency Approvals

- CSA Certified File LR701228



BRYANT®

| Bryant® Flexible Eye, Closed Mesh Light Duty Low Tension Pulling Grips | | | | | | |
|--|----------------------------------|--|------------------------|-------------------------|---------------|-------|
| Part Number | Cable Diameter Range Inches (cm) | Approximate Breaking Strength (Pounds/Newtons) | Eye Length Inches (cm) | Mesh Length Inches (cm) | Weight (lbs.) | Price |
| PA075 | 0.75-0.99 (1.90-2.51) | 4,000 (17,792) | 6.0 (15.24) | 12.0 (30.48) | 0.3 | <---> |
| PA100 | 1.00-1.24 (2.54-3.15) | 5,300 (23,574) | 7.0 (17.78) | 13.0 (33.02) | 0.4 | <---> |
| PA125 | 1.25-1.49 (3.17-3.78) | 5,300 (23,574) | 7.0 (17.78) | 14.0 (35.56) | 0.4 | <---> |
| PA150 | 1.50-1.74 (3.81-4.42) | 6,800 (30,246) | 8.0 (20.32) | 15.0 (38.10) | 0.6 | <---> |

E = Eye Length

M = Mesh Length



CAUTION: Never use grip to approximate breaking strength. Refer to technical data page for safety and working load factors. Banding is necessary to guard against accidental release of grip and provide maximum reliability.

Junior Low Tension Pulling Grips

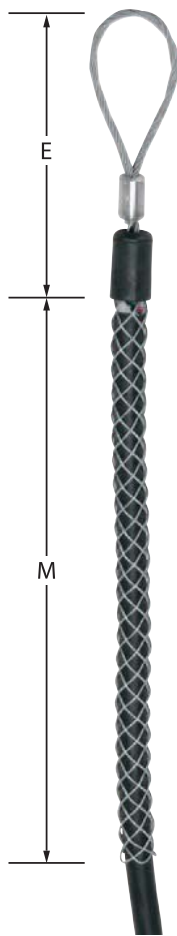

PJ075

Features

- Single weave variable mesh provides uniform positive grip power
- High strength galvanized steel
- Flexible eye easily attaches to pulling line snake or fish tape
- Reusable
- Pulls one or several cables
- Installs easily over building wire

Applications

- Utility work
- Service lines in industrial and commercial buildings
- Light-duty underground transmission lines stringing

Agency Approvals

- CSA Certified File LR701228

BRYANT®



| Bryant® Flexible Eye, Closed Mesh Junior Low Tension Pulling Grips | | | | | | |
|--|----------------------------------|--|------------------------|-------------------------|---------------|-------|
| Part Number | Cable Diameter Range Inches (cm) | Approximate Breaking Strength (Pounds/Newtons) | Eye Length Inches (cm) | Mesh Length Inches (cm) | Weight (lbs.) | Price |
| PJ025 | 0.25-0.36 (0.63-0.91) | 450 (2,002) | 3.25 (8.25) | 4.25 (10.79) | 0.1 | <--> |
| PJ037 | 0.37-0.49 (0.94-1.24) | 900 (4,003) | 3.75 (9.52) | 7.00 (17.78) | 0.1 | <--> |
| PJ050 | 0.50-0.61 (1.27-1.55) | 1,300 (5,782) | 4.25 (10.79) | 8.50 (21.59) | 0.1 | <--> |
| PJ062 | 0.62-0.74 (1.57-1.88) | 1,950 (8,674) | 5.00 (12.70) | 10.00 (25.40) | 0.1 | <--> |
| PJ075 | 0.75-0.99 (1.90-2.51) | 2,800 (12,454) | 5.75 (14.60) | 10.00 (25.40) | 0.2 | <--> |
| PJ100 | 1.00-1.24 (2.54-3.15) | 3,900 (17,347) | 6.50 (16.51) | 11.50 (29.21) | 0.3 | <--> |

E = Eye Length

M = Mesh Length

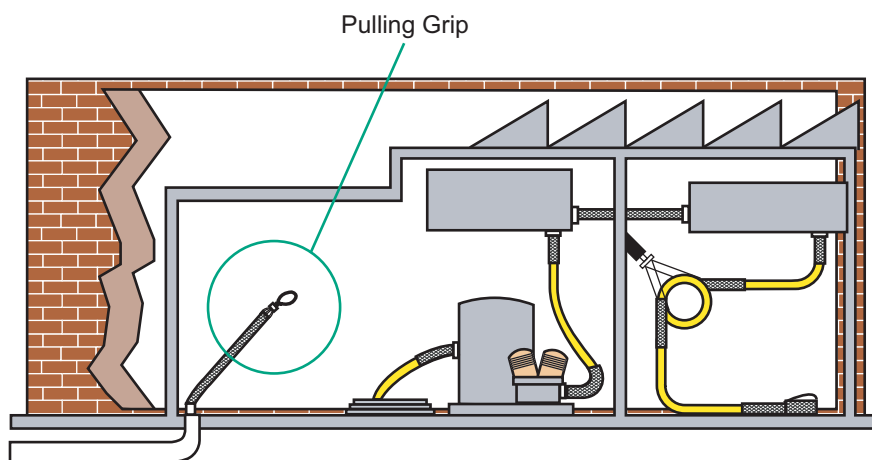

CAUTION: Never use grip to approximate breaking strength. Refer to technical data page for safety and working load factors. Banding is necessary to guard against accidental release of grip and provide maximum reliability.

Technical Data

Working Load Factors for Wire Mesh Grips

There are many variables associated with the use of wire mesh cable grips. Working load is an estimation of several factors including tension, cable diameter, number of cables gripped, gripping surface and more. Safety factors associated in the product's use must be considered together with the effects of abrasion, corrosion, prior use and abuse and other variables specific to the application.

The appropriate breaking strength of a Bryant® cable grip

represents an average calculation based on data established from actual testing performed in our engineering laboratories. Under normal usage conditions, the recommended factor of safety is 5 for pulling grips and 10 for support grips.

Any warranty as to quality, performance or fitness-for-use of the grips is always premised on the condition that the published strengths apply only to new, unused grips, and that such products are properly stored, handled, used, maintained and inspected by the user at a frequency appropriate for the use and condition of the grip.

Example

| Grip Style | Part Number | Approximate Breaking Strength | Safety Factor | Max. Recommended Load |
|------------|-------------|-------------------------------|---------------|-----------------------|
| Pulling | PA075 | 4000 lbs. | 5 | 800 lbs. |
| Support | SPC150U | 1610 lbs. | 10 | 161 lbs. |

Note: The maximum recommended working load is the greatest tension to be exerted on a grip for any application, with a margin of safety to protect against unforeseen and unusual circumstances.

Wire Mesh Grip Materials

| Material | Features | Product Group |
|--------------------------------|---|--|
| Galvanized steel wire | High strength Not subject to continuous outside environment | Pulling grips Bus drop grips Strain relief grips |
| Tin-Coated bronze wire | Corrosion-resistant for normal outside areas Non-magnetic Moderate strength | Support grips |
| Stainless steel wire (302/304) | Corrosion resistant | Strain relief grips |

Applicable Code Requirements:

Bryant Economy Cable Grips meet the following requirements

| | |
|-------------|--|
| NEC® 300.19 | Support of conductors in vertical raceways |
| NEC® 350 | Liquidtight flexible metal conduit termination |
| NEC® 400.14 | Flexible cord and cable protection |
| NEC® 400.10 | Strain relief at joints and terminals |

Operating Temperatures

| Material | Temperature Range |
|----------------------------|-----------------------------------|
| Aluminum | -40°F to +300°F (-40°C to +149°C) |
| Aluminum Deluxe Cord Grips | -30°F to +240°F (-34°C to +115°C) |

Hazardous Locations

| | Product Categories |
|--|--|
| The product categories listed on the right are suitable for use in hazardous locations per Class I Div. 2, Class II Div. 1 & 2, Class III Div. 1 & 2 | Deluxe cord grip, aluminum fitting Dust-tight strain relief grips |

Flammability (Non-metallic deluxe cord Grips will not support combustion)

| Component | Rating |
|-----------|----------|
| Mesh Grip | UL 94HB |
| Fitting | UL 94V-2 |

Wet Locations

| | Product Categories |
|--|------------------------------------|
| The products noted to the right are suitable for use in wet locations when a listed sealing ring is used between box and fitting | Deluxe cord grip, aluminum fitting |

Multiple Cable/Grip Selection Chart

Multiple Cable Selection Charts for Cables and Wires of Unequal Diameters

How to choose the correct grip size:

1. Find the grip circumference range by measuring the circumference of the bundle of different diameter cables to be gripped (see illustration).
2. Divide the bundle circumference by 3.14 to determine the diameter.
3. Choose a grip offering a range of cable diameters the same as the cable diameter.

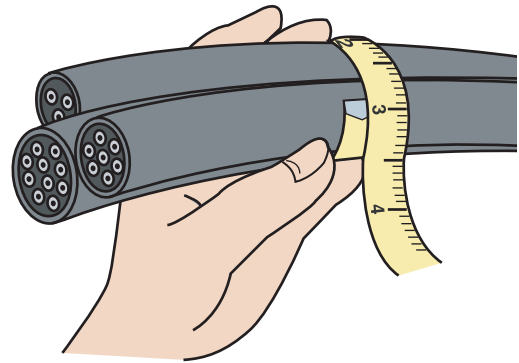

Selection Chart for Determining Grip Size for Multiple Equal Diameter Cables Held in a Single Grip

- 1 Under "Number of Cables in One Grip", find the diameter range of your cables in vertical column. Read Grip Size and Grip Diameter Range to the left.
- 2 If your diameter is the maximum of the range shown, stay with the same size grip.
- 3 Example: 3 cables, each with 0.89" (2.26 cm) diameter, select a 1.50"-1.74" (3.81 cm - 4.42 cm) range or 150 Grip Size.

| | | Number of Cables in One Grip | | | | | | | |
|---------------------|-----------|------------------------------|--------------------------|--------------------------|--------------------------|--------------------------|--------------------------|--------------------------|--------------------------|
| | Grip Size | Grip Dia. Range Inches (cm) | 2 | 3 | 4 | 5 | 6 / 7 | 8 | 9 |
| Pulling and Support | 50 | 0.50-0.61 (1.27-1.55) | 0.30-0.38 (0.76-0.97) | 0.25-0.31 (0.63-0.79) | 0.22-0.27 (0.56-0.69) | 0.19-0.24 (0.48-0.61) | 0.17-0.22 (0.43-0.56) | 0.15-0.19 (0.38-0.48) | 0.14-0.18 (0.36-0.46) |
| | 62 | 0.62-0.74 (1.57-1.88) | 0.38-0.44 (0.97-1.12) | 0.31-0.36 (0.79-0.91) | 0.27-0.31 (0.69-0.79) | 0.24-0.29 (0.61-0.74) | 0.22-0.26 (0.56-0.66) | 0.19-0.23 (0.48-0.58) | 0.18-0.21 (0.46-0.53) |
| | 75 | 0.75-0.99 (1.90-2.51) | 0.44-0.59 (1.12-1.50) | 0.36-0.49 (0.91-1.24) | 0.31-0.42 (0.79-1.07) | 0.29-0.38 (0.74-0.97) | 0.26-0.34 (0.66-0.86) | 0.23-0.31 (0.58-0.79) | 0.21-0.28 (0.53-0.71) |
| | 100 | 1.00-1.24 (2.54-3.15) | 0.59-0.75 (1.50-1.90) | 0.49-0.63 (1.24-1.60) | 0.42-0.54 (1.07-1.37) | 0.38-0.48 (0.97-1.22) | 0.34-0.43 (0.86-1.09) | 0.31-0.39 (0.79-0.99) | 0.28-0.35 (0.71-0.89) |
| | 125 | 1.25-1.49 (3.17-3.78) | 0.75-0.90 (1.90-2.29) | 0.63-0.76 (1.60-1.93) | 0.54-0.65 (1.37-1.65) | 0.48-0.58 (1.22-1.47) | 0.43-0.52 (1.09-1.32) | 0.39-0.46 (0.99-1.17) | 0.35-0.42 (0.89-1.07) |
| | 150 | 1.50-1.74 (3.81-4.42) | 0.90-1.07 (2.29-2.72) | 0.76-0.89 (1.93-2.26) | 0.65-0.77 (1.65-1.96) | 0.58-0.67 (1.47-1.70) | 0.52-0.60 (1.32-1.52) | 0.46-0.54 (1.17-1.37) | 0.42-0.49 (1.07-1.24) |
| | 175 | 1.75-1.99 (4.44-5.05) | 1.07-1.22 (2.72-3.10) | 0.89-1.02 (2.26-2.59) | 0.77-0.88 (1.96-2.24) | 0.67-0.77 (1.70-1.96) | 0.60-0.69 (1.52-1.75) | 0.54-0.62 (1.37-1.57) | 0.49-0.56 (1.24-1.42) |
| | 200 | 2.00-2.49 (5.08-6.32) | 1.22-1.53 (3.10-3.89) | 1.02-1.28 (2.59-3.25) | 0.88-1.10 (2.24-2.79) | 0.77-0.96 (1.96-2.44) | 0.69-0.86 (1.75-2.18) | 0.62-0.77 (1.57-1.96) | 0.56-0.71 (1.42-1.80) |
| | 250 | 2.50-2.99 (6.35-7.59) | 1.53-1.83 (3.89-4.65) | 1.28-1.53 (3.25-3.89) | 1.10-1.32 (2.79-3.35) | 0.96-1.16 (2.44-2.95) | 0.86-1.03 (2.18-2.62) | 0.77-0.93 (1.96-2.36) | 0.71-0.85 (1.80-2.16) |
| | 300 | 3.00-3.49 (7.62-8.86) | 1.83-2.14 (4.65-5.44) | 1.53-1.79 (3.89-4.55) | 1.32-1.54 (3.35-3.91) | 1.16-1.35 (2.95-3.43) | 1.03-1.20 (2.62-3.05) | 0.93-1.08 (2.36-2.74) | 0.85-0.99 (2.16-2.51) |
| | 350 | 3.50-3.99 (8.89-10.13) | 2.14-2.44 (5.44-6.20) | 1.79-2.05 (4.55-5.21) | 1.54-1.76 (3.91-4.47) | 1.35-1.54 (3.43-3.91) | 1.20-1.37 (3.05-3.48) | 1.08-1.24 (2.74-3.15) | 0.99-1.13 (2.51-2.87) |
| | 400 | 4.00-4.49 (10.16-11.40) | 2.44-2.75 (6.20-6.98) | 2.05-2.30 (5.21-5.84) | 1.76-1.98 (4.47-5.03) | 1.54-1.74 (3.91-4.42) | 1.37-1.55 (3.48-3.94) | 1.24-1.39 (3.15-3.53) | 1.13-1.27 (2.87-3.23) |
| | 450 | 4.50-4.99 (11.43-12.67) | 2.75-3.06 (6.98-7.77) | 2.30-2.56 (5.84-6.50) | 1.98-2.20 (5.03-5.59) | 1.74-1.93 (4.42-4.90) | 1.55-1.72 (3.94-4.37) | 1.39-1.55 (3.53-3.94) | 1.27-1.41 (3.23-3.58) |

**Automation
Direct**

Over 12,000 high-quality industrial automation products

**Spend Less.
Demand More!**



**from your industrial
controls supplier**

**VOTED #1
Best in
SERVICE
12 YEARS**

2001 - 2012



**Programmable
Controllers & I/O**



Universal Field I/O



Software



Operator Interface



**AC Drives and
Soft Starters**



**Motors and
Motor Controls**



Motion Control



**Safety
Components**



Pneumatics



Process



Relays and Timers



Sensors



**Pushbuttons,
Switches and Lights**



**Terminal Blocks
and Wiring**



**Communications
and I/O Wiring**



Communications



Power Products



Enclosures



Circuit Protection



Tools

#1 Value in Automation

A quality product line, with FREE #1 rated technical support and quick shipping!
Call 1-800-633-0405 or visit us at: www.automationdirect.com

Wiring Devices – Product Features

TECH·SPEC®

Hand grip features wide-rib, non-slip design

Configuration-specific plug face surrounds blades to prevent infiltration of contaminants

Face and body feature alignment keys for easy assembly

Amperage, voltage and NEMA configuration imprinted on face for easy identification

Double wall construction for extra durability

Captive, combination Slot/Phillips assembly screws

Neutral blade is nickel-plated for easy identification

Impact/chemical resistant; toughened nylon construction

BRYANT®



High Performance Contact

High-performance copper-alloy contacts have excellent conductivity and spring properties to provide superior contact pressure. Clamp-type terminals have .078 inch thick over-sized clamp nut with undercut for secure retention of conductor. Captive combination phillips/slotted #10 brass terminal screws are color-coded for easy wiring.

EPDM Dust Seal



(Ethylene Propylene Diene Monomer)
Resilient dust seal surrounds cord, helping prevent moisture and contaminants from entering wiring chamber. Tapered cover eliminates snagging.

Triple Gripper®



Internal "self-centering" Triple Gripper® cord grip with "radius teeth" design provides secure cord retention.

Terminal Cover



Transparent terminal cover, extended "teardrop" wiring pockets and backed out "captive" terminal screws simplify wiring.

Angle Adapter



Nylon angle adapter (catalog number 70204ANA) converts 20A and 30A nylon locking plugs and connectors into space-saving angle devices.

Wiring Devices – Product Features

TECH·SPEC®

Combination back and side wiring terminals accept #14 thru #8 AWG solid or stranded conductors

Captive terminal screws are deep slotted for easy installation

Base is molded of rugged reinforced thermoplastic polyester to minimize heat buildup and resist breakage. Thick wall construction provides terminal isolation and strong support for current-carrying parts

One-piece, rivetless copper-alloy contact design reduces heat buildup and provides secure blade retention

High strength #10 terminal screws resist corrosion and provide secure terminations

Captive, combination Slot/Phillips mounting screws

Heavy-duty mounting straps are nickel-plated to resist corrosion; wide width design assures secure assembly

NEMA rating and configuration are molded into face for easy identification

Face is molded of toughened nylon to resist breakage

Space-saving design allows more room in box for wiring

Both mounting straps are grounded for safe installations

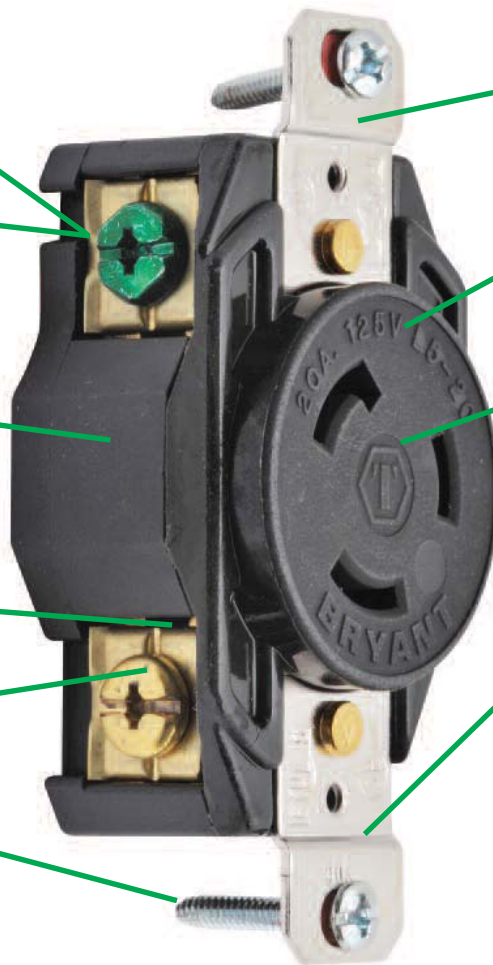

BRYANT®

70520FR

Wiring Device Selection

When selecting wiring devices, there are various plug options which will work with coordinating connectors or plugs.

Plug

Step 1



Step 2

- OR -

Some applications may require a wall receptacle to be used with the coordinating plug.

Receptacle



Connector

Other applications may require the use of a connector for extending the length of a cable with coordinating plug type.

Step 2



Watertight Wiring Devices - Product Features

TECH-SPEC®

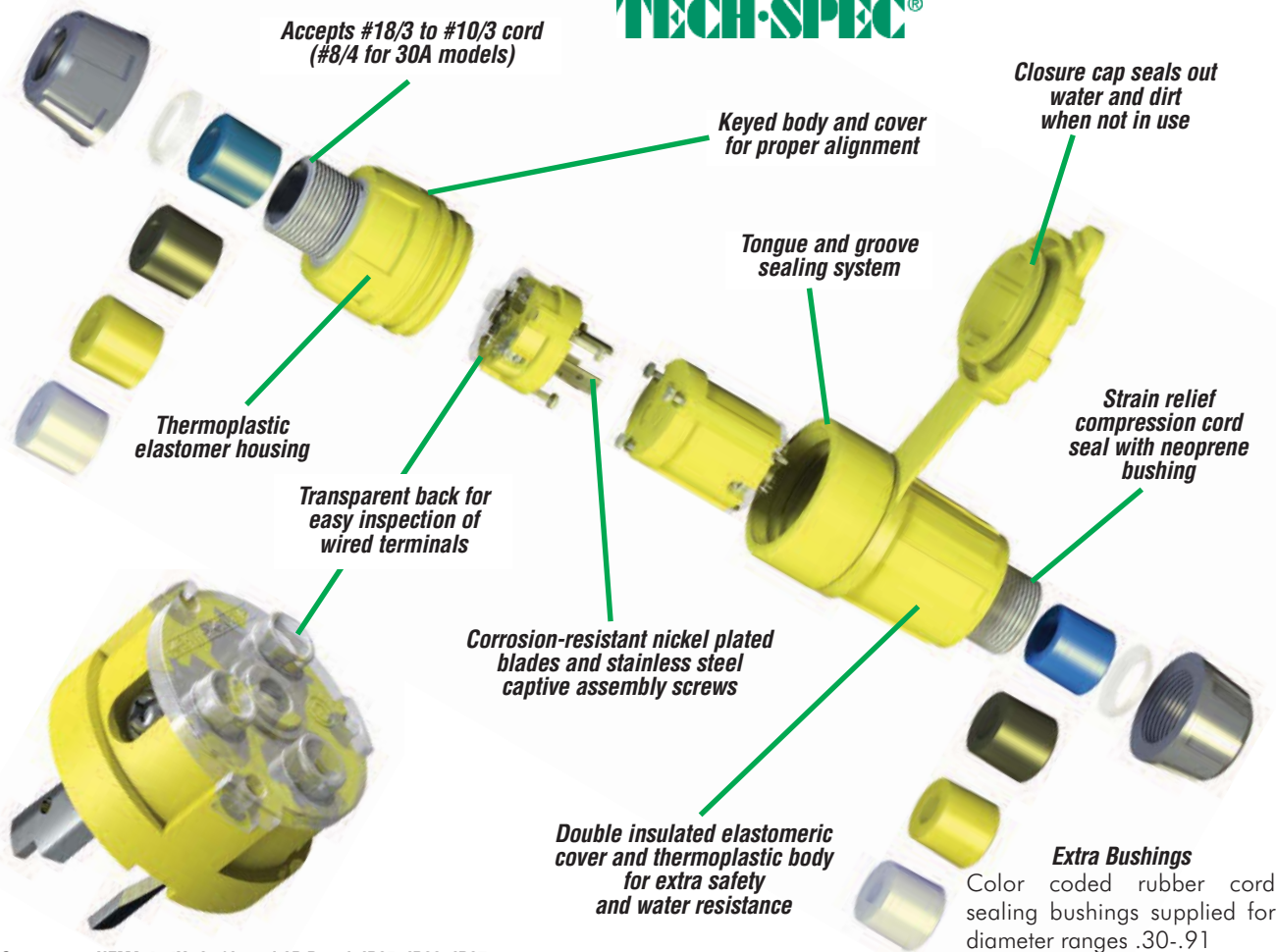

Connectors: NEMA 4, 4X, 6, 12, and 6P Rated; IP65, IP66, IP67

Plugs: NEMA 4, 4X, 6, and 6P Rated; IP65, IP66, IP67

Weather Protective NEMA Type 1

BRYANT®

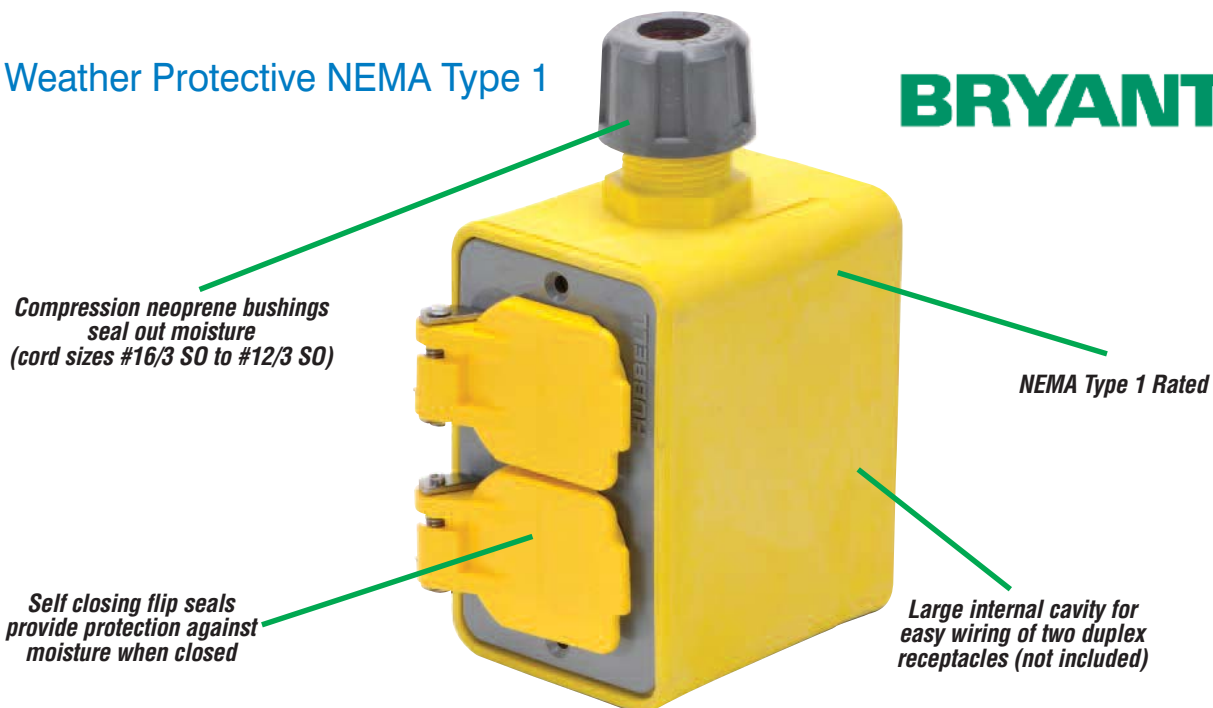

Duplex Receptacles – Product Features

Extra Heavy Duty Industrial Grade Duplex Receptacles

TECH·SPEC®

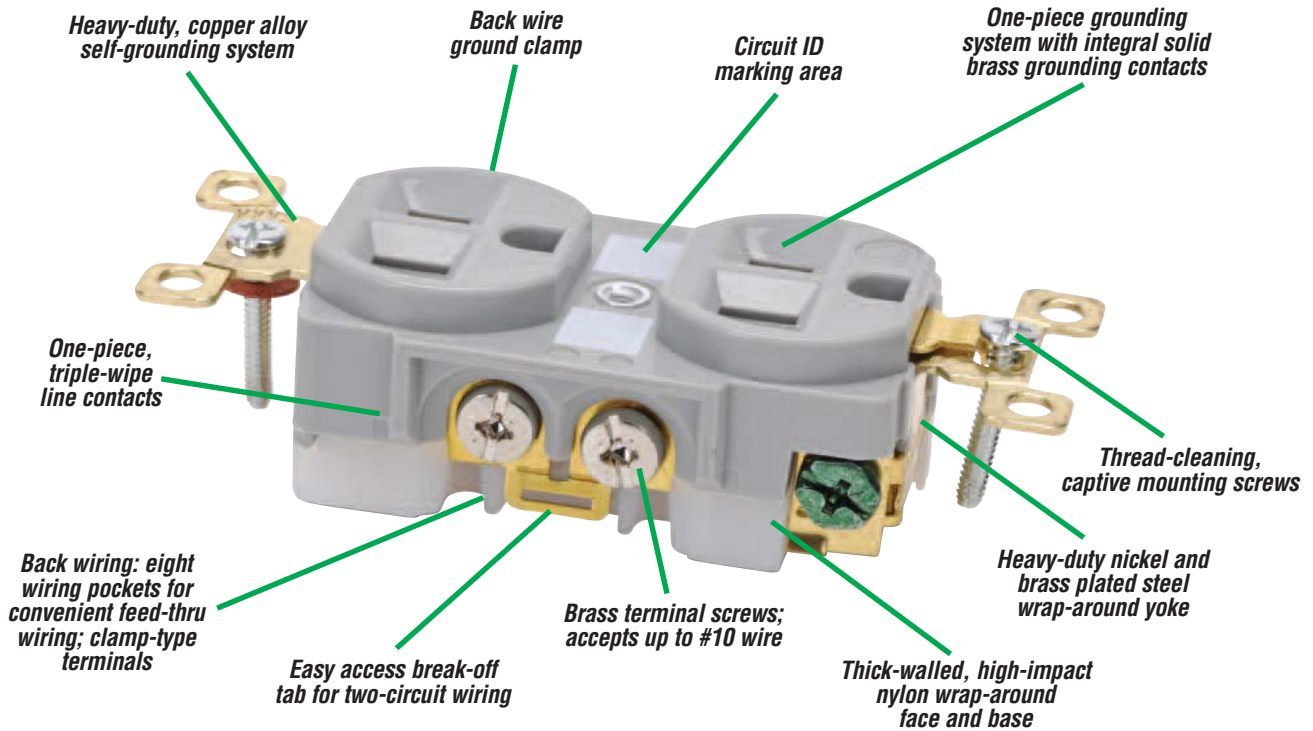

Corrosion-Resistant Duplex Receptacles

BRYANT®

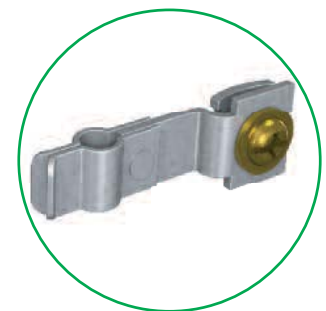
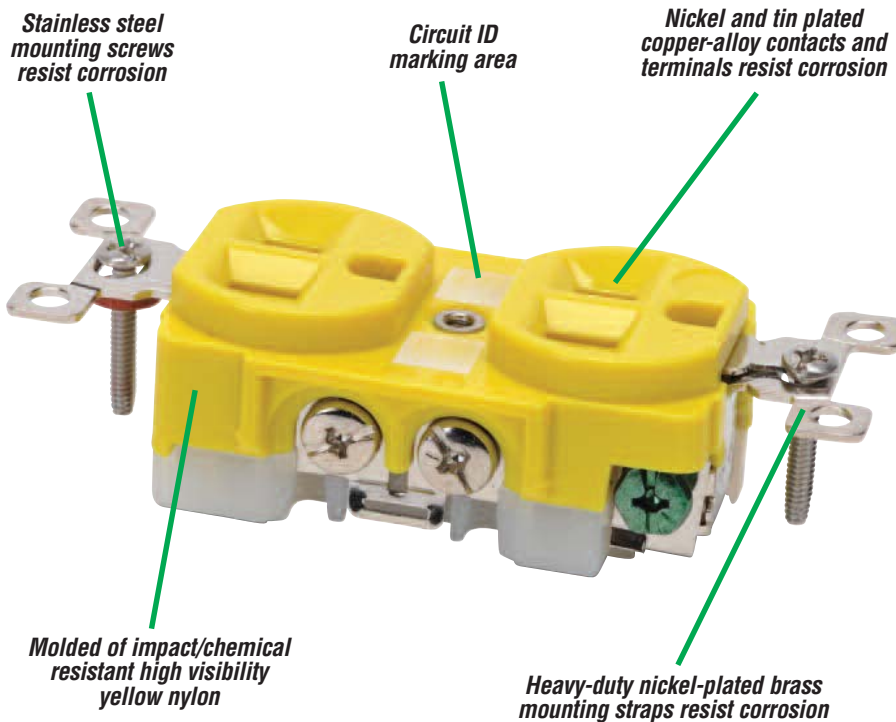

One-piece rivetless copper-alloy power contacts reduce heat buildup and provide secure plug blade retention

Wiring Devices – Locking Plugs / Connectors / Receptacles

TECH-SPEC®

Features

- Internal Triple-Gripper® cord clamp with unique “radius teeth” design automatically centers and secures the cord
- Tough impact- and chemical-resistant nylon housing
- Double-wall construction
- Combination Phillips/slotted captive terminal screws
- Transparent terminal cover with clear window and teardrop wiring pockets to ease insertion of stranded wire and to make solid connections
- Copper wire only
- Captive, quick-thread assembly screws backed out, ready for assembly
- Integral thermoplastic elastomer dust seal surrounds cord to help prevent moisture and contaminants from entering the wiring chamber
- Nickel-plated neutral blade for easy identification
- Amperage, voltage and NEMA configuration imprinted on face for easy identification
- See wiring devices technical information Table III for horsepower ratings



BRYANT®

Note: See Table III at the end of the Wiring Devices section for Horsepower Ratings

Agency Approvals







- UL File E2258 (Receptacle), E1381 (Plug, Connector)
- CSA Certified 16215





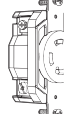







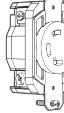

| 15 Amp Locking Devices | | | | | | | | | | | | |
|------------------------|--------|---------|----------------------|----------------|-------|-------|--------------------|-------|-------|---------------------|-------|-------|
| Poles | NEMA # | Voltage | Configuration | Plug Part No. | Style | Price | Connector Part No. | Style | Price | Receptacle Part No. | Style | Price |
| 2-Pole 3-Wire | L5-15 | 125V | L5-15R L5-15P | 4721NP | | <---> | 4732NC | | <---> | 4710 | | <---> |
| | L6-15 | 250V | L6-15R L6-15P | 70615NP | | <---> | 70615NC | | <---> | 70615FR | | <---> |
| | L7-15 | 277V AC | L7-15R L7-15P | 4770NP | | <---> | 4779NC | | <---> | 4760 | | <---> |



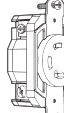

| 20 Amp Locking Devices | | | | | | | | | | | | |
|------------------------|--------|---------|----------------------|----------------|-------|-------|--------------------|-------|-------|---------------------|-------|-------|
| Poles | NEMA # | Voltage | Configuration | Plug Part No. | Style | Price | Connector Part No. | Style | Price | Receptacle Part No. | Style | Price |
| 2-Pole 3-Wire | L5-20 | 125V | L5-20R L5-20P | 70520NP | | <---> | 70520NC | | <---> | 70520FR | | <---> |
| | L6-20 | 250V | L6-20R L6-20P | 70620NP | | <---> | 70620NC | | <---> | 70620FR | | <---> |
| | L7-20 | 277V AC | L7-20R L7-20P | 70720NP | | <---> | 70720NC | | <---> | 70720FR | | <---> |
| | L8-20 | 480V AC | L8-20R L8-20P | 70820NP | | <---> | 70820NC | | <---> | 70820FR | | <---> |
| | L9-20 | 600V AC | L9-20R L9-20P | 70920NP | | <---> | 70920NC | | <---> | 70920FR | | <---> |



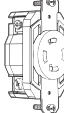

Wiring Devices – Locking Plugs / Connectors / Receptacles

| 30 Amp Locking Devices | | | | | | | | | | | | |
|------------------------|--------|---------|---|----------------|---|-------|--------------------|--|-------|---------------------|---|-------|
| Poles | NEMA # | Voltage | Configuration | Plug Part No. | Style | Price | Connector Part No. | Style | Price | Receptacle Part No. | Style | Price |
| 2-Pole 3-Wire | L5-30 | 125V |  | 70530NP |  | <---> | 70530NC |  | <---> | 70530FR |  | <---> |
| | L6-30 | 250V |  | 70630NP | | <---> | 70630NC | | <---> | 70630FR | | |
| | L7-30 | 277V AC |  | 70730NP | | <---> | 70730NC | | <---> | 70730FR | | |
| | L8-30 | 480V AC |  | 70830NP | | <---> | 70830NC | | <---> | 70830FR | | |
| | L9-30 | 600V AC |  | 70930NP | | <---> | 70930NC | | <---> | 70930FR | | |

| 20 Amp Locking Devices | | | | | | | | | | | | |
|------------------------|--------|--------------|---|----------------|--|-------|--------------------|---|-------|---------------------|--|-------|
| Poles | NEMA # | Voltage | Configuration | Plug Part No. | Style | Price | Connector Part No. | Style | Price | Receptacle Part No. | Style | Price |
| 3-Pole 4-Wire | L14-20 | 125V/250V AC |  | 71420NP |  | <---> | 71420NC |  | <---> | 71420FR |  | <---> |
| | L15-20 | 3Ø 250V AC |  | 71520NP | | <---> | 71520NC | | <---> | 71520FR | | |
| | L16-20 | 3Ø 480V AC |  | 71620NP | | <---> | 71620NC | | <---> | 71620FR | | |

| 30 Amp Locking Devices | | | | | | | | | | | | |
|------------------------|--------|--------------|---|----------------|---|-------|--------------------|--|-------|---------------------|---|-------|
| Poles | NEMA # | Voltage | Configuration | Plug Part No. | Style | Price | Connector Part No. | Style | Price | Receptacle Part No. | Style | Price |
| 3-Pole 4-Wire | L14-30 | 125V/250V AC |  | 71430NP |  | <---> | 71430NC |  | <---> | 71430FR |  | <---> |
| | L15-30 | 3Ø 250V AC |  | 71530NP | | <---> | 71530NC | | <---> | 71530FR | | |
| | L16-30 | 3Ø 480V AC |  | 71630NP | | <---> | 71630NC | | <---> | 71630FR | | |
| | L17-30 | 3Ø 600V AC |  | 71730NP | | <---> | 71730NC | | <---> | 71730FR | | |

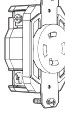
| 20 Amp Locking Devices | | | | | | | | | | | | |
|------------------------|--------|----------------------|---|----------------|---|-------|--------------------|--|-------|---------------------|---|-------|
| Poles | NEMA # | Voltage | Configuration | Plug Part No. | Style | Price | Connector Part No. | Style | Price | Receptacle Part No. | Style | Price |
| 4-Pole 5-Wire | L21-20 | 3ØY 120V/ 208V AC |  | 72120NP |  | <---> | 72120NC |  | <---> | 72120FR |  | <---> |
| | L22-20 | 3ØY 277V/ 480V AC |  | 72220NP | | <---> | 72220NC | | <---> | 72220FR | | |

| 30 Amp Locking Devices | | | | | | | | | | | | |
|------------------------|--------|----------------------|---|----------------|---|-------|--------------------|--|-------|---------------------|---|-------|
| Poles | NEMA # | Voltage | Configuration | Plug Part No. | Style | Price | Connector Part No. | Style | Price | Receptacle Part No. | Style | Price |
| 4-Pole 5-Wire | L21-30 | 3ØY 120V/ 208V AC |  | 72130NP |  | <---> | 72130NC |  | <---> | 72130FR |  | <---> |
| | L22-30 | 3ØY 277V/ 480V AC |  | 72230NP | | <---> | 72230NC | | <---> | 72230FR | | |

Wiring Devices – Locking Plugs / Connectors / Receptacles Specifications and Drawings

| 15 Amp Locking Devices General Specifications | | | | | |
|---|-------------------------|--|--|--------------------------------|---|
| Part Type | Maximum Working Voltage | Operating/Storage Temperature | Terminal Accomodation | Cord Grip Range inches (mm) | Torque Specifications |
| Plug | 600VAC/250VDC | Maximum of 140°F (60°C) continuous, minimum of -40°F (-40°C) without impact. | Fork slot = 0.390 x 0.060 terminal screw #8 #18 - #8 AWG Flexible Cord (copper wire) | 0.300"-0.655" (7.62-16.637) | Terminal screw 12-14 lb-in (1.4-1.6 N-m) Assembly screw 8 lb-in (0.9 N-m) |
| Connector | | Maximum of 140°F (60°C) continuous, minimum of -40°F (-40°C) without impact. | Fork slot = 0.390 x 0.060 terminal screw #8 #18 - #8 AWG Flexible Cord (copper wire) | .300"-0.655" (7.62-16.637) | Terminal screw 12-14 lb-in (1.4-1.6 N-m) Assembly screw 8 lb-in (0.9 N-m) |
| Receptacle | | -40°F to 185°F (-40°C to 85°C) continuous without impact | Fork slot = 0.400 x 0.060 terminal screw #10 #14 - #8 AWG (solid or stranded copper wire) | N/A | Terminal screw 12-14 lb-in (1.4-1.6 N-m) Assembly screw 8 lb-in (0.9 N-m) |

| 20/30 Amp Locking Devices General Specifications | | | | | |
|--|-------------------------|--|--|-------------------------------|--|
| Part Type | Maximum Working Voltage | Operating/Storage Temperature | Terminal Accomodation | Cord Grip Range inches (mm) | Torque Specifications |
| Plug | 600VAC/250VDC | Maximum of 140°F (60°C) continuous, minimum of -40°F (-40°C) without impact. | Fork slot = 0.400 x 0.060 terminal screw #10 #18 - #8 AWG Flexible Cord (copper wire) | 0.300"-0.950" (7.62-24.13) | Terminal screw 12-14 lb-in (1.4-1.6 N-m) Assembly screw 10 lb-in (1.2 N-m) |
| Connector | | Maximum of 140°F (60°C) continuous, minimum of -40°F (-40°C) without impact. | Fork slot = 0.400 x 0.060 terminal screw #10 #18 - #8 AWG Flexible Cord (copper wire) | 0.300"-0.950" (7.62-24.13) | Terminal screw 12-14 lb-in (1.4-1.6 N-m) Assembly screw 10 lb-in (1.2 N-m) |
| Receptacle | | -40°F to 185°F (-40°C to 85°C) continuous without impact | Fork slot = 0.400 x 0.060 terminal screw #10 #14 - #8 AWG (solid or stranded copper wire) | N/A | Terminal screw 12-14 lb-in (1.4-1.6 N-m) Assembly screw 8 lb-in (0.9 N-m) |

Note: 20/30 Amp locking plugs/connector terminal screws are tri-drive.

Wiring Devices – Locking Plugs / Connectors / Receptacles Drawings

15 Amp Dimensions

Dimensions in inches [mm]

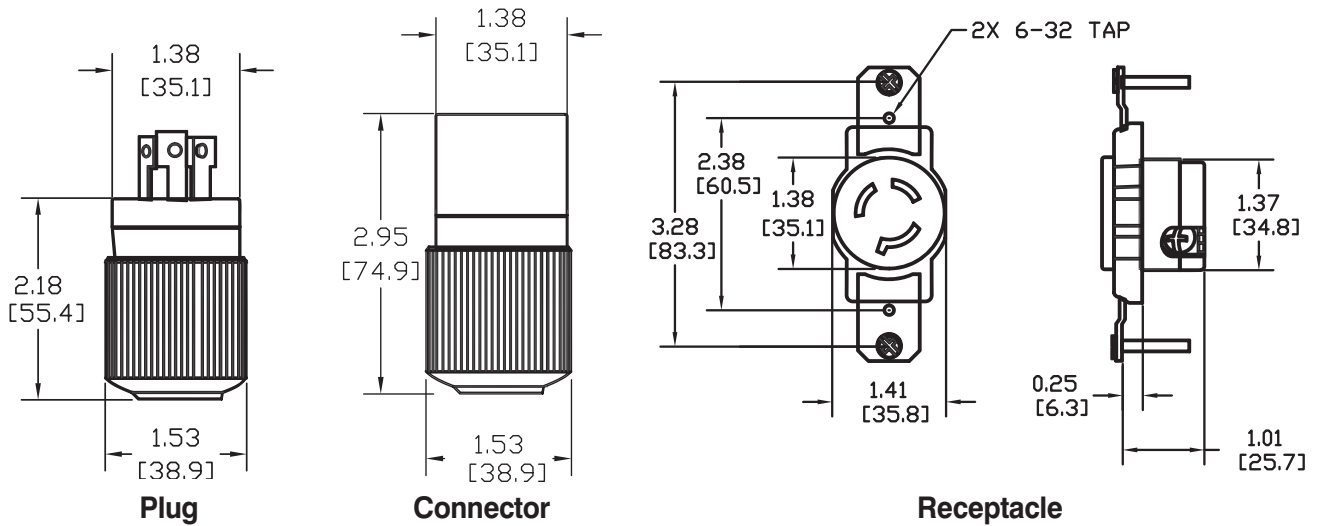

Dimensions in [mm]

20/30 Amp Dimensions

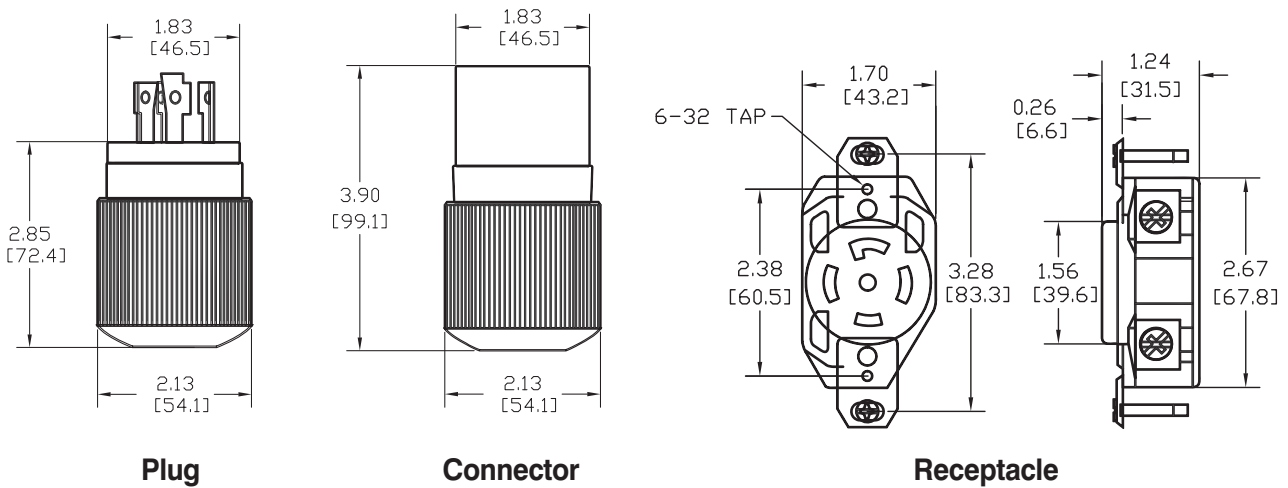

Note: Dimensional drawings provided for reference only, not all items are shown.

Wiring Devices – Straight Blade Plugs / Connectors

TECH·SPEC®

BRYANT®

Features

- Internal Triple-Gripper® cord clamp with unique “radius teeth” design automatically centers and secures the cord
- Tough impact- and chemical-resistant nylon housing
- Double-wall construction
- Combination Phillips/slotted captive terminal screws
- Transparent terminal cover with clear window and teardrop wiring pockets to ease insertion of stranded wire and to make solid connections
- Captive, quick-thread assembly screws backed out, ready for assembly
- Copper wire only
- Insulated design shields exposed metal parts on hand-held side

- Integral thermoplastic elastomer dust seal surrounds cord to help prevent moisture and contaminants from entering the wiring chamber
- Ratings stamped on straight blade devices visible while in use (15 and 20A)
- Face and body feature contrasting key for correct and easy assembly every time
- Universal cord grip design accepts 0.300” to 0.655” (7.6 to 16.6 mm) cord without inserts or adapters (15 and 20A); 0.425” to 1.320” (10.80 to 33.5 mm)



Agency Approvals

- UL File E2258 (Receptacle), E1381, E3382 (Plug, Connector)
- CSA Certified 16215





| 15 Amp Straight Devices | | | | | | | | | |
|-------------------------|--------|---------|-----------------|------------------|-------|-------|--------------------|-------|-------|
| Poles | NEMA # | Voltage | Configuration | Plug Part No. | Style | Price | Connector Part No. | Style | Price |
| 2-Pole 3-Wire | 5-15 | 125V | 5-15R 5-15P | BRY5266NP | | <---> | BRY5269NC | | <---> |
| | 6-15 | 250V | 6-15R 6-15P | BRY5666NP | | <---> | BRY5669NC | | <---> |

| 20 Amp Straight Devices | | | | | | | | | |
|-------------------------|--------|---------|-----------------|------------------|-------|-------|--------------------|-------|-------|
| Poles | NEMA # | Voltage | Configuration | Plug Part No. | Style | Price | Connector Part No. | Style | Price |
| 2-Pole 3-Wire | 5-20 | 125V | 5-20R 5-20P | BRY5366NP | | <---> | BRY5369NC | | <---> |
| | 6-20 | 250V | 6-20R 6-20P | BRY5466NP | | <---> | BRY5469NC | | <---> |

| 30 Amp Straight Devices | | | | | | | | | |
|-------------------------|--------|---------|-----------------|---------------|-------|-------|--------------------|-------|-------|
| Poles | NEMA # | Voltage | Configuration | Plug Part No. | Style | Price | Connector Part No. | Style | Price |
| 2-Pole 3-Wire | 5-30 | 125V | 5-30R 5-30P | 9530NP | | <---> | 9530NC | | <---> |
| | 6-30 | 250V | 6-30R 6-30P | 9630NP | | <---> | 9630NC | | <---> |

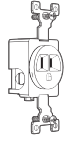

Wiring Devices – Single Straight Blade Receptacles

BRYANT®

| 15 Amp Single Receptacles | | | | | | |
|---------------------------|--------|---------|--|-------------|---|-------|
| Poles | NEMA # | Voltage | Configuration | Part Number | Style | Price |
| 2 Pole 3 Wire | 5-15 | 125V |  5-15R | 5251 |  | <--> |
| | 6-15 | 250V |  6-15R | 5661 | | <--> |



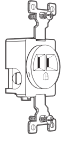

5251

| 20 Amp Single Receptacles | | | | | | |
|---------------------------|--------|---------|--|-------------|---|-------|
| Poles | NEMA # | Voltage | Configuration | Part Number | Style | Price |
| 2 Pole 3 Wire | 5-20 | 125V |  5-20R | 5361 |  | <--> |
| | 6-20 | 250V |  6-20R | 5461 | | <--> |

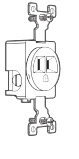

5361

| 30 Amp Single Receptacles | | | | | | |
|---------------------------|--------|---------|--|---------------|---|-------|
| Poles | NEMA # | Voltage | Configuration | Part Number | Style | Price |
| 2 Pole 3 Wire | 5-30 | 125V |  5-30R | 9530FR |  | <--> |
| | 6-30 | 250V |  6-30R | 9630FR | | <--> |



9530FR

Wiring Devices – Straight Blade Plugs / Connectors / Receptacles Specifications and Drawings

| Straight Blade Devices General Specifications | | | | | |
|---|-------------------------|--|---|--|--|
| Part Type | Maximum Working Voltage | Operating/Storage Temperature | Terminal Accomodation | Cord Grip Range | Torque Specifications |
| Plug | 250VAC/DC | Maximum of 140°F (60°C) continuous, minimum of -40°F (-40°C) without impact | 15/20 Amp Fork slot = 0.390 x 0.060 terminal screw #8 | 15/20 amp = 0.245"-0.655" (6.2-16.6mm) | 15/20 amp = Terminal screw 12-14 lb-in (1.4-1.6 N-m) Assembly screw 12 lb-in (1.3 N-m) |
| | | | | 30 amp = 0.425"-0.320" (10.8-33.5mm) | 30 amp = Terminal screw 20-24 lb-in (2.26-2.712 N-m) Assembly screw 10-12 lb-in (1.2-1.356 N-m) |
| #18 - #10 AWG Flexible Cord (copper wire) | | | 15/20 amp = 0.245"-0.655" (6.2-16.6mm) | 15/20 amp = Terminal screw 12-14 lb-in (1.4-1.6 N-m) Assembly screw 12 lb-in (1.3 N-m) | |
| | | | 30 amp = 0.425"-0.320" (10.8-33.5mm) | 30 amp = Terminal screw 20-24 lb-in (2.26-2.712 N-m) Assembly screw 10-12 lb-in (1.2-1.356 N-m) | |
| Connector | | | Fork slot = 0.400 x 0.060 terminal screw #10 #14 - #10 AWG (solid or stranded copper wire) | N/A | 15/20 amp = Terminal screw 14 lb-in (1.6 N-m) |
| Single Receptacle (15 & 20 amp) | | | | N/A | 30 amp = Terminal screw 25 lb-in (3.0 N-m) |
| Single Receptacle (30 amp) | N/A | 15/20 amp = Terminal screw 14 lb-in (1.6 N-m) | | | |
| Duplex Receptacle (15 & 20 amp) | | Fork slot = 0.400 x 0.060 terminal screw #10 #14 - #10 AWG (copper conductors only) | N/A | 15/20 amp = Terminal screw 14 lb-in (1.6 N-m) | |

15/20 Amp Dimensions

Dimensions in inches [mm]

Single Straight Blade Plug

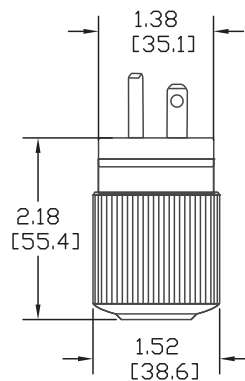

Single Straight Blade Connector

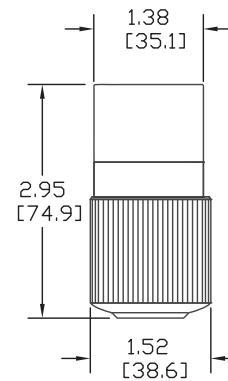

Single Straight Blade Receptacle

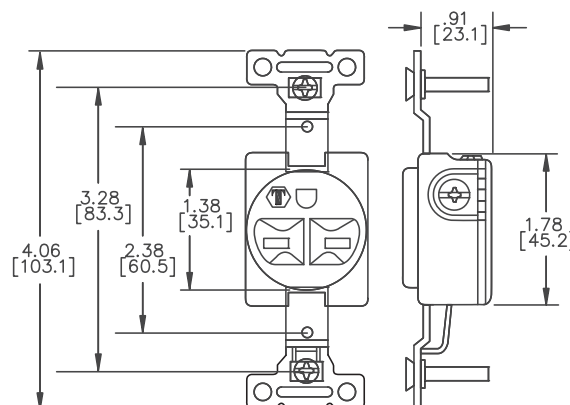

Wiring Devices – Straight Blade Plugs / Connectors / Receptacles Specifications and Drawings

30 AMP Dimensions

Dimensions in inches [mm]

Single Straight Blade Plug

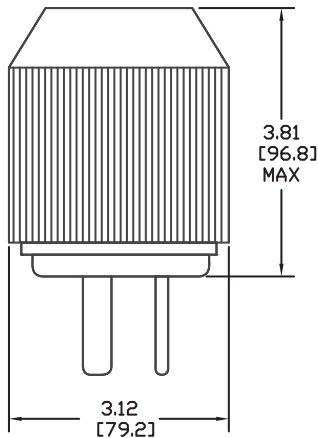

Single Straight Blade Connector

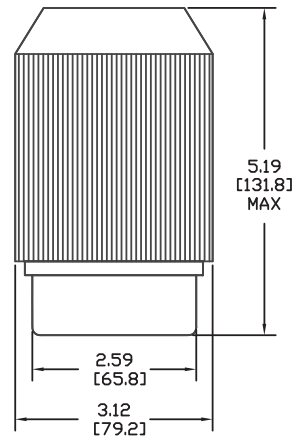

Single Straight Blade Receptacle

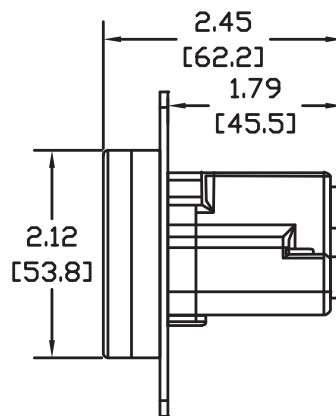
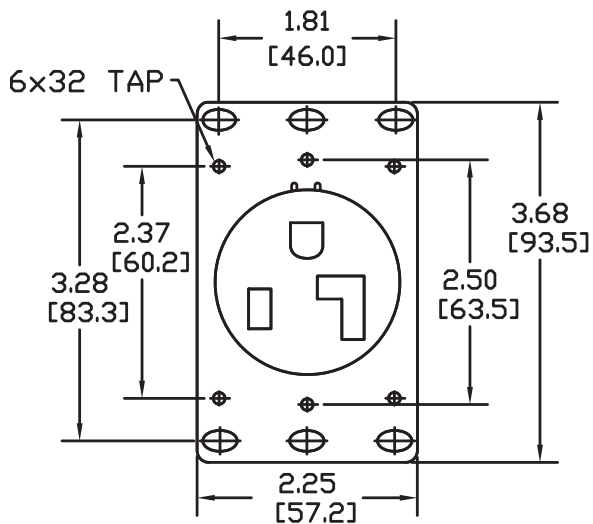

Wiring Devices – Accessories



Features

Nylon Angle Adapter

- Converts 20A and 30A nylon locking plugs and connectors into space saving angle devices
- Adapters permit wire to exit parallel to the receptacle; eliminating space needed for wire to bend

Weather Protective Boots; 5200 Series

- For use with Bryant 15 and 20 Amp straight blade plugs and connectors and 15 Amp locking plug and connectors
- Help prevent moisture, dust and other contaminants from infiltrating plugs and connectors
- Available in high visibility yellow or standard black
- Thermoplastic elastomer construction
- Excellent ozone and weather resistance
- Resistant to deterioration by oils and heat
- IP 55 Suitability when installed and used properly with plug and connector body combinations
- Connector sealing ring provides extra protection when plug and connector are not mated
- Ribbed exterior provides firm grip

Weather Protective Boots; 7200 Series

- For use with Bryant 20 and 30 Amp locking plugs and connectors
- Help prevent moisture, dust and other contaminants from infiltrating plugs and connectors
- Chemical/UV-resistant construction
- Available in high visibility yellow or standard black
- Ribbed exterior provides firm grip
- Sealing ring seals connector when not mated
- For use with Bryant Triple Gripper® 20 and 30 Amp nylon plugs and connectors
- IP 55 Suitability when installed and used properly with plug and connector body combinations

Stainless Steel Cover Plates

Approvals

- UL File E31999*
- CSA Certified 18416*



*Approvals for stainless steel receptacle plates only.

| Wiring Devices Accessories | | |
|----------------------------|--|-------|
| Part Number | Description | Price |
| Cover Plates | | |
| SS8 | Duplex receptacle plate, stainless steel, 15A and 20A straight blade, single-gang box | <--> |
| SS7 | Single receptacle plate, stainless steel, 15A and 20A straight blade, 15A locking, single-gang box | <--> |
| SS723 | Single receptacle plate, stainless steel, 30A straight blade, single-gang box | <--> |
| SS703 | Single receptacle plate, stainless steel, 30A straight blade, two-gang box | <--> |
| SS720 | Single receptacle plate, stainless steel, 20A and 30A locking, single-gang box | <--> |
| Angle Adapter* | | |
| 70204ANA | Angle adapter for 20A and 30A locking plugs and connectors | <--> |
| Weather Boots* | | |
| 5200BP | Weather boot for 15A locking, 15A straight, and 20A straight blade plugs. YELLOW thermoplastic elastomer | <--> |
| 5200BC | Weather boot for 15A locking, 15A straight, and 20A straight blade connector. YELLOW thermoplastic elastomer | <--> |
| 5200BSR | Connector boot sealing ring for 5200BC boot. YELLOW thermoplastic elastomer | <--> |
| 5200BPB | Weather boot for 15A locking, 15A straight, and 20A straight blade plugs. BLACK thermoplastic elastomer | <--> |
| 5200BCB | Weather boot for 15A locking, 15A straight, and 20A straight blade connector. BLACK thermoplastic elastomer | <--> |
| 5200BSRB | Connector boot sealing ring for 5200BC boot. BLACK thermoplastic elastomer | <--> |
| 72002BC | Weather boot for 20A and 30A locking plug. YELLOW neoprene | <--> |
| 72002BP | Weather boot for 20A and 30A locking connector. YELLOW neoprene | <--> |
| 72002BSR | Connector boot sealing ring for 72002BC boot. YELLOW thermoplastic elastomer | <--> |
| 72002BPB | Weather boot for 20A and 30A locking plugs. BLACK thermoplastic elastomer | <--> |
| 72002BCB | Weather boot for 20A and 30A locking connectors. BLACK thermoplastic elastomer | <--> |
| 72002BSRB | Connector boot sealing ring for 72002BCB boot. BLACK thermoplastic elastomer | <--> |



Stainless Steel Receptacle Plates



Angle Adapter 70204ANA

*Angle adapter and weather boots are not UL listed or CSA certified.

Wiring Devices – Accessories



**72002BC
Weather Boot**



**72002BC with 72002BSR
Connector Boot sealing ring**

Note: Connectors shown on above installations are not included and are purchased separately.



**Angle Adapter
70204ANA**

+



=



+



=



Angle Adapter Dimensions

Dimensions in inches [mm]

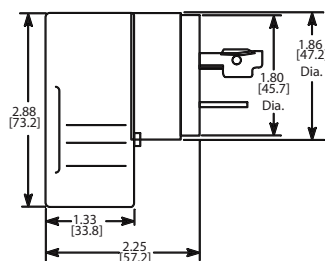
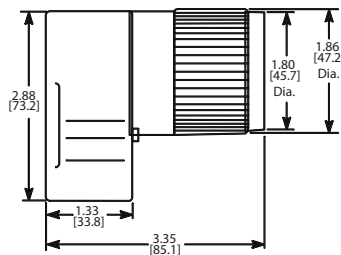

Angle Adapter

Wiring Devices – Accessories Drawings

Stainless Steel Cover Plates

Dimensions in inches [mm]

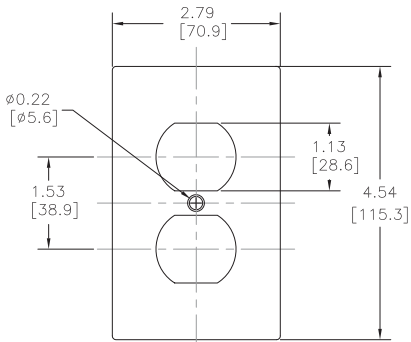

SS8

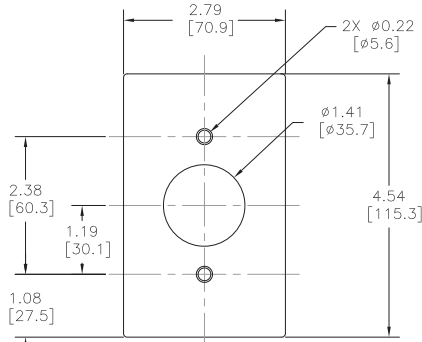

SS7

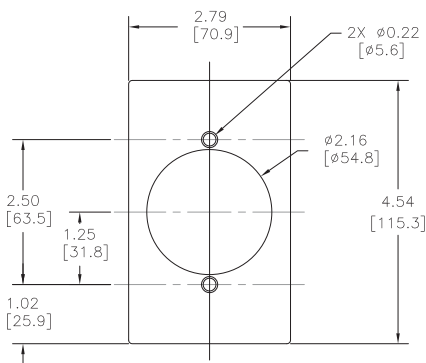

SS723

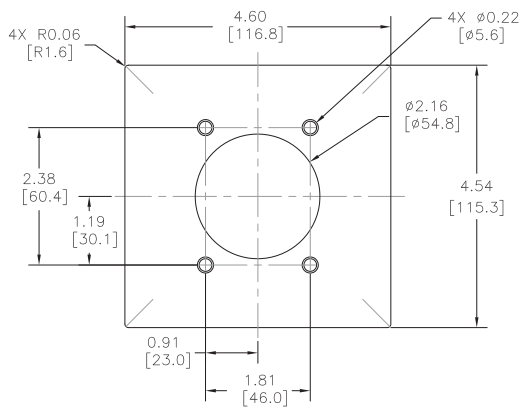

SS703

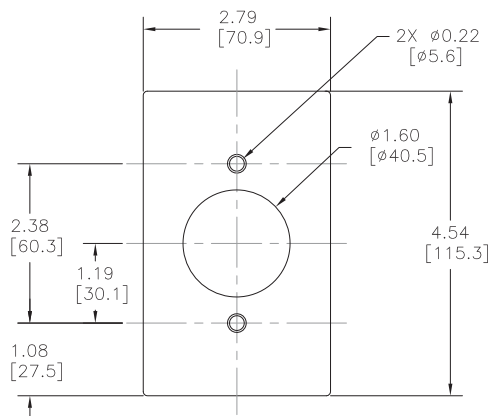

SS720

Wiring Devices – Technical Information

Reference material only. Please see Wiring Section in the catalog for product part number.

| Mechanical And Electrical Properties Of Materials | | | | | | |
|---|------------------------------|-------------------------|------------------------|------------------------|---------------------------------------|--|
| Properties | 6/6 Nylon | 6 Nylon | Polycarbonate | PC/PET | Phenolic | Urea |
| Tensile Strength (PSI) | 11,000 | 6,000+* | 9,000 | 6,000 | 6,500-10,000 | 5,500-13,000 |
| Elongation (%) | 300+* | 300* | 130 | 120 | 0.4 - 0.8 | 0.5 - 1.0 |
| Flex. Mod. (Stiffness)(PSI) | 175,000* | 140,000* | 340,000 | 325,000 | 1,000,000 | 1,500,000 |
| Izod (Notched) ft.-lb./in. | 2.1 lb-in [0.24 Nm]* | 3.0 lb-in [0.34 Nm]* | 15.0 lb-in [1.7 Nm] | 12.0 lb-in [1.36Nm] | 0.3 to 1.9 lb-in [.034 to 0.21 Nm] | 0.25 to 0.4 lb-in [0.03 to 0.05 Nm] |
| Hardness Rockwell | 59M* 108R* | - 119R | 70M 118R | - 115R | 105-120M - | 110-120M - |
| Heat Deflection Temperature | 66 PSI | 464°F (240°C) | 370°F (187.7°C) | - | 265°F (129.4°C) | - |
| | 264 PSI | 194°F (90°C) | 185°F (85°C) | 270°F (132°C) | 260°F (126.6°C) | 400°F (204.4°C) |
| UL Thermal Index | Electrical | 257°F (125°C) | 257°F (125°C) | 257°F (125°C) | 221°F (105°C) | 302°F (150°C) |
| | Mechanical w/ Impact | 167°F (75°C) | 167°F (75°C) | 239°F (115°C) | | |
| | Mechanical w/o Impact | 185°F (85°C) | 185°F (85°C) | 257°F (125°C) | | |
| Flame Class UL 94 | V-2 | V-2 | V-2 | V-0 | HB-V0 | HB-V0 |
| Dielectric V/mil | 600 | 400 | 380 | 307 | 200-400 | 300-400 |
| Specific Gravity | 1.14 | 1.13 | 1.2 | 1.33 | 1.4 | 1.5 |
| UL Comparative Tracking Index (Volts) | 600+ | 600+ | 250+ | 230 | 175+ | 600+ |

*Conditioned to 50% relative humidity

| Chemical Resistance Of Materials | | | | |
|----------------------------------|-------|----------|------|---------------|
| Chemical | Nylon | Phenolic | Urea | Polycarbonate |
| Acids | C | B | B | A |
| Alcohol | A | A | A | B |
| Caustic Bases | A | B | B | C |
| Gasoline | A | A | C | A |
| Grease | A | A | A | B |
| Kerosene | A | A | A | A |
| Oil | A | A | A | B |
| Solvents | A | A | A | C |
| Water | A | A | A | A |

Note: A - Completely resistant. Good to excellent, general use.

B - Resistant. Fair to good, limited service.

C - Slow attack. Not recommended for use.

Watertight Wiring Devices - Plugs and Connectors

BRYANT®

Features

- High-visibility yellow thermoplastic elastomeric housing
- Rugged PBT interiors provide excellent resistance to moisture and temperature
- Tongue and groove plug to connector sealing system for optimum protection
- Nickel-plated contacts and blades
- Stainless steel captive assembly screws
- Accepts multiple cord diameters
- Operating temperature -40°C to 60°C
- Individual neoprene bushings provide watertight sealing
- 15-30 amp range up to 480 volts AC
- Keyed body and cover for proper alignment
- Recommended where moisture exists or casual submersion is possible
- Meets NEC requirements for "Wet & Damp Locations"
- Meets OSHA requirements

Agency Approvals/ Standards

- UL File E1381 Guide AXUT
- CSA Certified #701599
- Comply with NEMA standards WD-1, WD-6, AND UL498
- IP65, IP66, IP67



15W33BRY

Connectors: NEMA 4, 4X, 6, 12, and 6P Rated; IP65, IP66, IP67



14W47BRY

Plugs: NEMA 4, 4X, 6, and 6P Rated; IP65, IP66, IP67

TECH-SPEC®

| Watertight Plugs and Connectors Quick Selection Table | | | | | | | | | | | | |
|---|----------|--------|---------------|---------------|-------------|----------------|-----------------|-------|--------------------|-----------------|-------|------|
| Poles | Amperage | NEMA # | Voltage | Configuration | Device Type | Plug Part No. | Style | Price | Connector Part No. | Style | Price | |
| 2-Pole 3-Wire | 15 Amps | 5-15 | 125V AC | 5-15R | 5-15P | Straight Blade | 14W47BRY | | <--> | 15W47BRY | | <--> |
| | | L5-15 | 125V AC | L5-15R | L5-15P | Locking | 24W47BRY | | <--> | 25W47BRY | | <--> |
| | | L7-15 | 277V AC | L7-15R | L7-15P | Locking | 24W34BRY | | <--> | 25W34BRY | | <--> |
| | 20 Amps | 5-20 | 125V AC | 5-20R | 5-20P | Straight Blade | 14W33BRY | | <--> | 15W33BRY | | <--> |
| | | L5-20 | 125V AC | L5-20R | L5-20P | Locking | 26W47BRY | | <--> | 27W47BRY | | <--> |
| | | L6-20 | 250V AC | L6-20R | L6-20P | Locking | 26W48BRY | | <--> | 27W48BRY | | <--> |
| 3-Pole 4-Wire | 20 Amps | L15-20 | 250V AC 3Ø | L15-20R | L15-20P | Locking | 26W75BRY | | <--> | 27W75BRY | | <--> |
| | | L16-20 | 480V AC 3Ø | L16-20R | L16-20P | Locking | 26W76BRY | | <--> | 27W76BRY | | <--> |
| | 30 Amps | L15-30 | 250V AC 3Ø | L15-30R | L15-30P | Locking | 28W75BRY | | <--> | 29W75BRY | | <--> |
| | | L16-30 | 480V AC 3Ø | L16-30R | L16-30P | Locking | 28W76BRY | | <--> | 29W76BRY | | <--> |

Watertight Plugs and Connectors - Technical Specifications/Dimensions

| Watertight Devices Technical Specifications | | | | |
|---|---|--|--|--|
| Device type | 15A/20A Straight Blade 15A Locking | 20A Locking | 20A Locking 3-Phase | 30A Locking 3-Phase |
| Maximum working voltage | As marked | | | |
| Operating temperature | Maximum continuous 60°C [140°F], minimum -40°C [-40°F] (without impact) | | | |
| Terminal accomodation | Type S, SO, ST, SJ, SJO, SJT 18/3 to 12/3 | 12/3 SJ, 14/3 S to 10/3 S | 14/4 S to 10/4 S | 12/4 S to 8/4 S, 6/4 MSHA |
| Cord diameter | 0.300" to 0.625" (7.6 mm to 15.9 mm) | 0.475" to 0.720" (12.1 mm to 19.2 mm) | 0.560" to 0.775" (14.2 mm to 19.9 mm) | 0.640" to 0.930" (16.3 mm to 23.6 mm) |
| Torque specifications | Wire terminal screw 12-15 lb-in (1.4-1.7 N-m) Housing assembly screw 8-10 lb-in (0.9-1.13 N-m) | | | |
| Dielectric voltage | Plugs: 2500VAC if rated 300V or less, 3500VAC if rated above 300V Connectors: 2000VAC if rated 300V or less, 3000VAC if rated above 300V | | | |
| Environmental Plugs and Connectors* | Moisture Resistance - NEMA 4, 4x, 12, 6, 6P; IP65, IP66, IP67 | | | |

* Each plug or connector is individually tested for watertight integrity to meet the NEMA and IP ratings. Bryant can only claim NEMA and IP ratings when mated to other Bryant and Hubbell devices. This would be true for any manufacturer.

Dimensions in inches [mm]

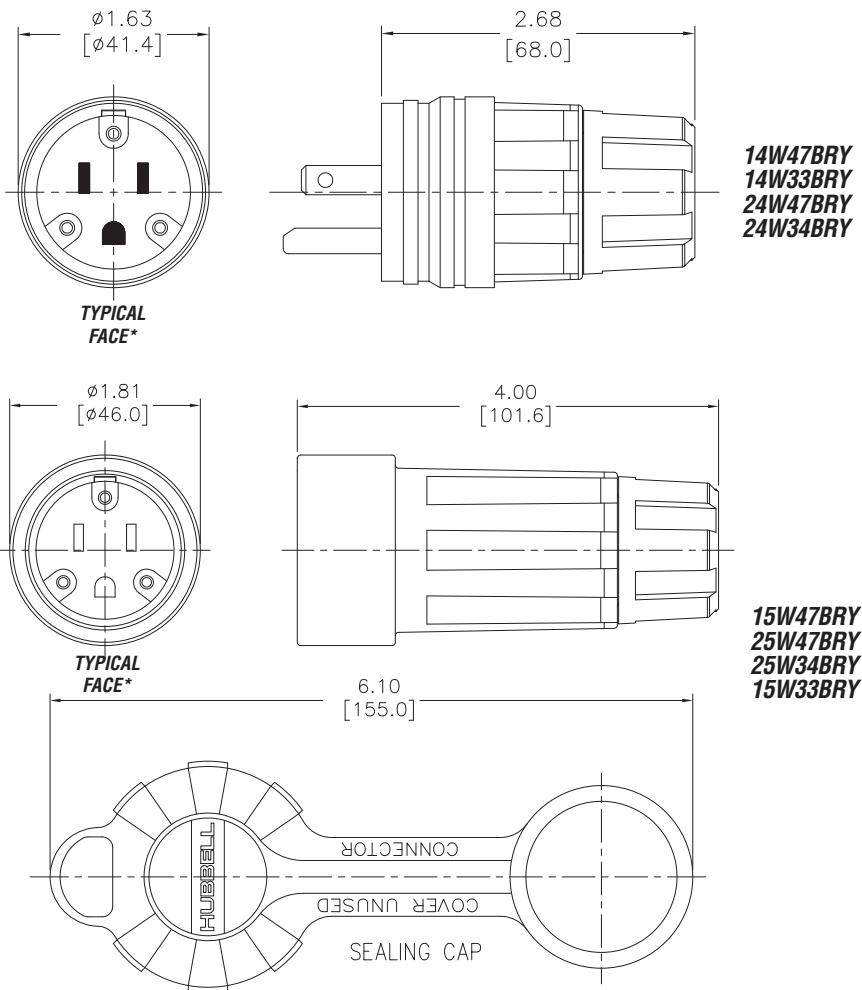

* Typical face only. Please reference Quick Selection Table for face configuration.

Watertight Plugs and Connectors - Dimensions (continued)

Dimensions in inches [mm]

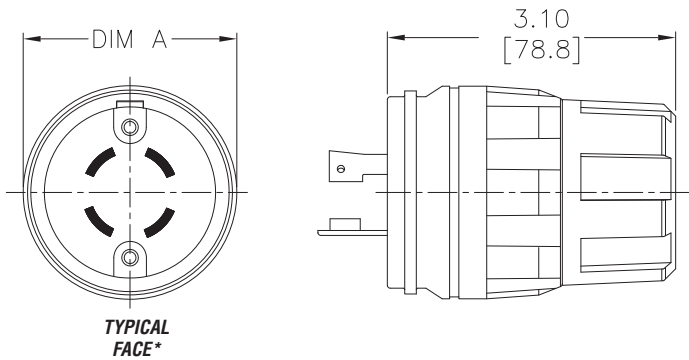

| Weather Protective Plugs | |
|--------------------------|-------------------|
| Part Number | DIM A Inches [mm] |
| 26W47BRY | 2.30 [58.4] |
| 26W48BRY | |
| 26W75BRY | |
| 26W76BRY | 2.50 [63.5] |
| 28W75BRY | |
| 28W76BRY | |

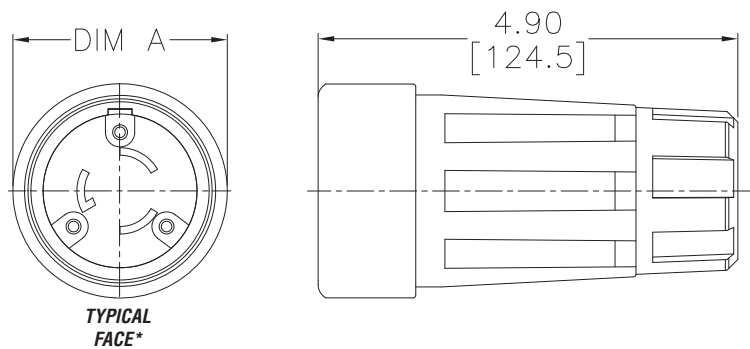

| Weather Protective Connectors | |
|-------------------------------|-------------------|
| Part Number | DIM A Inches [mm] |
| 27W47BRY | 2.50 [63.5] |
| 27W48BRY | |
| 27W75BRY | |
| 27W76BRY | 2.80 [71.1] |
| 29W75BRY | |
| 29W76BRY | |

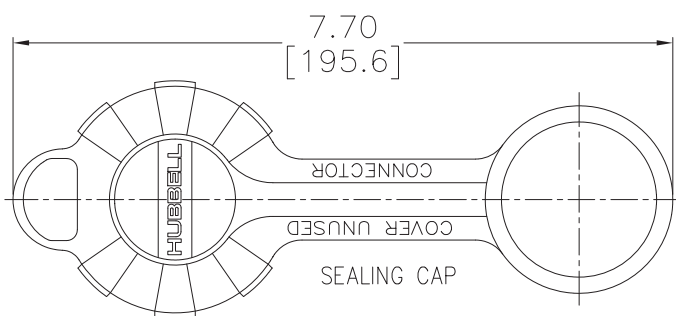

* Typical face only. Please reference Quick Selection Table for face configuration.

Industrial Grade Duplex Straight Blade Receptacles

TECH·SPEC®

BRYANT®



BRY5262CR



BRY5262GRY



BRY5262



BRY5362

Features

- One-piece grounding system, including integral self-grounding strap
- Full-face, wraparound design is molded of high-impact, chemical-resistant nylon
- Extended barrier (shroud) on sides of cover surround wire terminals for added insulation and isolation of conductors
- Heavy-duty wraparound steel yoke locked in for maximum strength and security
- Double-plated yoke (nickel & brass) to resist corrosion
- Back wiring: eight wiring pockets for convenient feed thru wiring, clamp-type terminals accept up to #10 wire
- Terminal screws: brass combination Phillips/slotted/Robertson binding head accepts up to #10 wire
- Approved for CU wire only
- Large green, combination Phillips/slotted/Robertson hex head grounding screw
- Back wire ground clamp for quick and convenient wiring
- Center splined bushing interlocks with receptacle body to prevent rotation when fastening wall plates
- Easily accessible break-off tab for two-circuit wiring
- ID surface on cover for marking clear identification of circuits
- One-piece triple-wipe brass line contacts
- Double-wipe brass grounding contacts
- Strip gauge for accurate wiring

Agency Approvals/Standards

- UL File E2258 Guide #RTRT
- CSA Certified File LR16215 Guide #365E1
- Complies with NEMA standards WD-1, WD-6, AND UL498
- Verified under Fed. Spec. #WC596 (where applicable)
- CE



| Duplex Straight Blade Receptacles | | | | | | | | |
|-----------------------------------|----------|--------|------------|---------------|-------------|--------|-------|-------|
| Poles | Amperage | NEMA # | Voltage | Configuration | Part Number | Color | Style | Price |
| 2 Pole 3 Wire | 15A | 5-15 | 125V AC/DC | | BRY5262GRY | Gray | | <---> |
| | | | | | BRY5262CR* | Yellow | | <---> |
| | | 6-15 | 250V AC/DC | | BRY5262 | Brown | | <---> |
| | | | | | BRY5662 | | | <---> |
| | 20A | 5-20 | 125V AC/DC | | BRY5362GRY | Gray | | <---> |
| | | | | | BRY5362CR* | Yellow | | <---> |
| | | 6-20 | 250V AC/DC | | BRY5362 | Brown | | <---> |
| | | | | | BRY5462 | | | <---> |

* Corrosion-resistant, nylon construction, self-grounding, back- and side-wired

Industrial Grade Duplex Straight Blade Receptacles Specifications and Drawings

| Duplex Straight Blade Receptacles Specifications | | | | |
|--|---|------------|------------|------------|
| Duplex Receptacle Part Numbers | BRY5262GRY | BRY5662 | BRY5363GRY | BRY5462 |
| | BRY5262 | | BRY5362 | |
| | BRY5262CR | | BRY5362CR | |
| Amperage | 15A | | 20A | |
| Maximum working voltage | 125V AC/DC | 250V AC/DC | 125V AC/DC | 250V AC/DC |
| Operating temperature | Maximum continuous 60°C, minimum -40°C (without impact) | | | |
| Temperature rise | Less than 30°C temperature rise at full rated current after 50 cycles overload at 150% rated current for either AC or DC applications per UL498 | | | |
| Terminal accommodation | #14-#10 AWG Copper conductor only | | | |
| Terminal screw | Fork slot = 0.400 x 0.060 terminal screw #10 | | | |
| Torque specifications | Terminal screw 14 lb-in (1.6 N-m) | | | |
| Dielectric voltage | Withstands 2000V per UL498 | | | |

Dimensions in inches [mm]

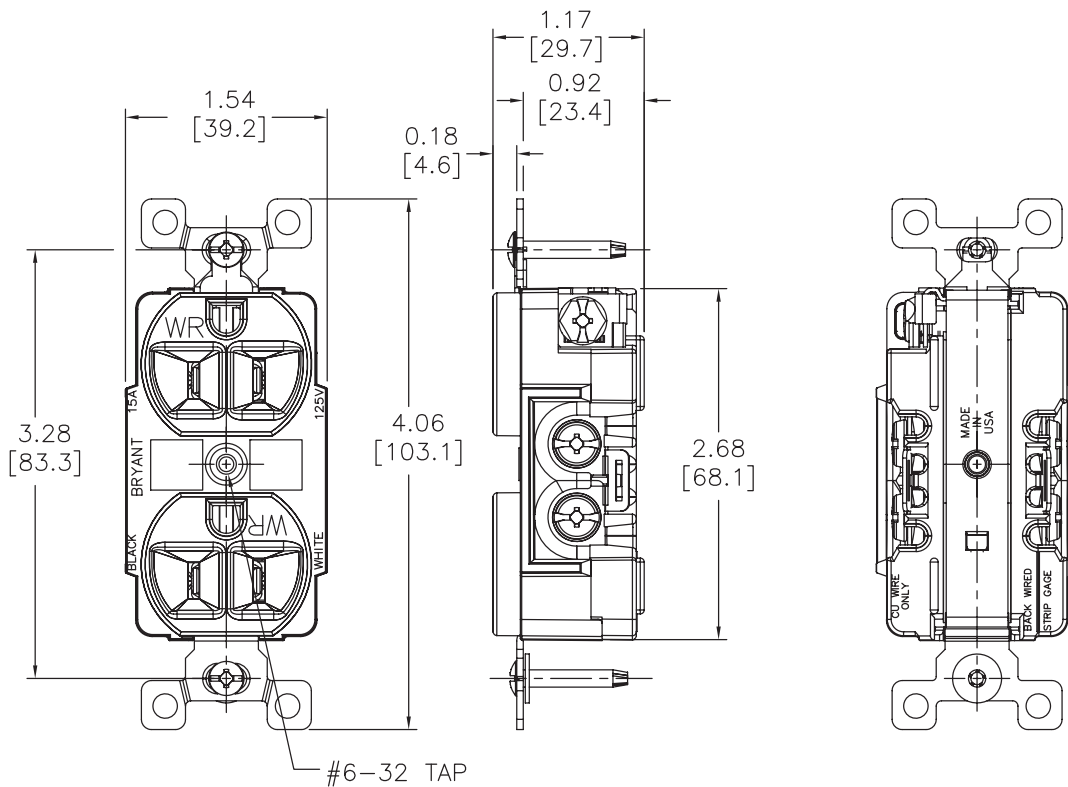

Weather Protective Accessories



Portable Outlet Boxes Features

- Non-conductive, impact resistant thermoplastic elastomer boxes reduce the exposure to potential hazards
- Automatic centering strain relief cord clamps
- NEMA Type 1
- Neoprene seal bushings accommodate cord size #16 SO to #12/3 SO
- For use with 15A or 20A duplex receptacles (receptacles not included)
- Flip seals protect against wet environments and moisture when closed

TECH-SPEC®

Dimensions in inches [mm]

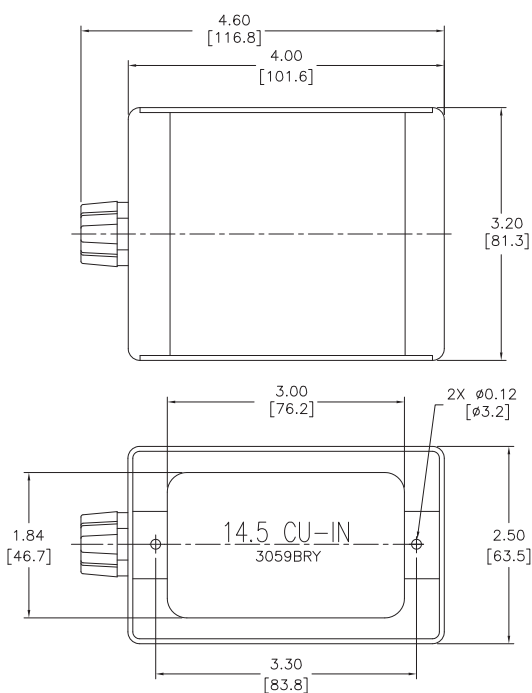

| Weather Protective Accessories | | |
|--------------------------------|---|-------|
| Part Number | Description | Price |
| 3059BRY | Portable outlet box | <---> |
| 3056BRY | Outlet box cover; duplex receptacle with lift cover | <---> |
| 3054BRY | Blank outlet box cover plate | <---> |

**Receptacle sold separately*

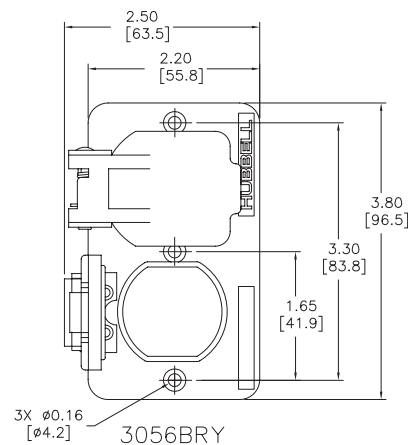
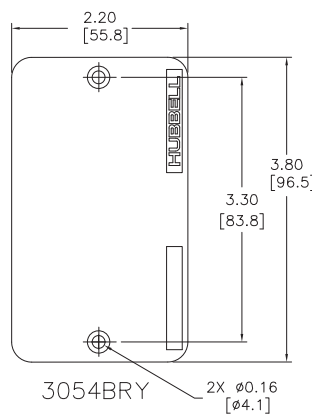

Material Specifications

| Watertight Wiring Devices Materials | |
|--|---|
| Plugs/Connectors | |
| Part Description | Materials |
| Blade/contact carrier | PBT thermoplastic, yellow |
| Terminal retainer | Polycarbonate, clear |
| Housing | Thermoplastic elastomer, yellow |
| Housing insert | Polypropylene, natural |
| Strain relief nut | PBT thermoplastic, gray |
| Grommet | Thermoplastic elastomer, various colors |
| Ferrule | Polypropylene, natural |
| Blades/contacts | Brass, nickel |
| Terminal screws | Steel, chromate |
| Terminal screw size | #8-32 |
| Body holding screws | Stainless steel |
| Drive screws | Steel, chromate |
| Portable Outlet Box and Accessories | |
| Box enclosure | Thermoplastic elastomer, yellow |
| Strain relief nut | PBT thermoplastic, gray |
| Grommet | Thermoplastic elastomer, various colors |
| Ferrule | Polypropylene, natural |
| Strain relief insert | Nylon, yellow |
| Locknut | Steel, zinc plate |
| Threaded inserts | Polypropylene, natural |
| Strain relief wire | Brass |
| Duplex receptacle screw | Stainless steel |
| Cover plate screws | Steel, black oxide |
| Cover plate | Nylon, gray |
| Flip cover | PBT Thermoplastic, yellow |
| Flip cover seal | Foam rubber, black |
| Cover plate spring | Stainless steel |
| Hinge pin | Aluminum |
| Hinge bracket | Stainless steel |
| Rivets | Brass |

Wiring Devices – Lockouts

PLUGBOX™ - Devices



Features

- OSHA lockout/tagout regulation 29CFR 1910.147 compliance
- Protect against unexpected start-up of equipment during maintenance and repair work
- Plugs are locked safely in sturdy enclosure
- Discourages unauthorized use of tools and equipment
- Stores and protects plug when equipment is not in use or during relocation. Stores on cable when not in use.
- UV-stabilized polypropylene housing
- High-visibility red for easy identification
- Available in 3 sizes to accommodate a full range of plug designs and ratings
- BLD and BLD2 accept up to 3/8" (9.7) lock shackle diameter. BLDMP accepts 5/16" (7.9) lock shackle diameter.
- Openings for attachment of identification tag

BRYANT®

Dimensions

Dimensions in inches [mm]

| Wiring Devices – Lockouts | | |
|---------------------------|---|-------|
| Part Number | Description | Price |
| BLDMP | Lockout device, small (3-wire, 15A, molded-on plugs, up to 277V rating), Red | <---> |
| BLD | Lockout device, medium (3-4-5-wire, 15A, 20A, and 30A plugs), Red | <---> |
| BLD2 | Lockout device, large (4- and 5-wire, 30A, plugs and 3- and 4- wire 50A plugs), Red | <---> |

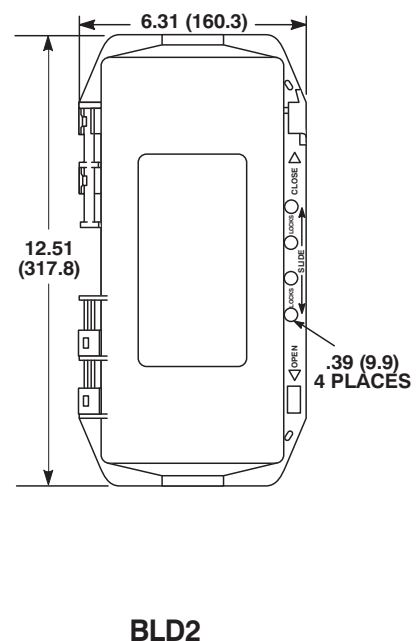
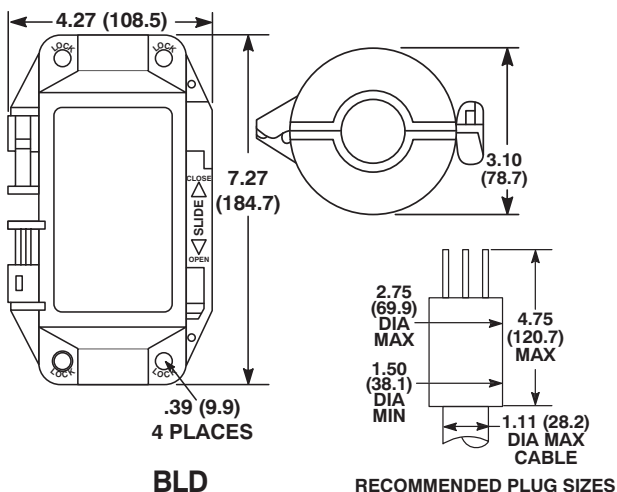
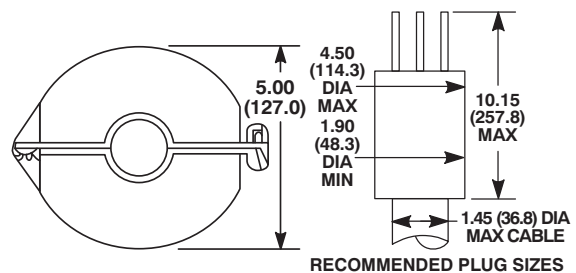
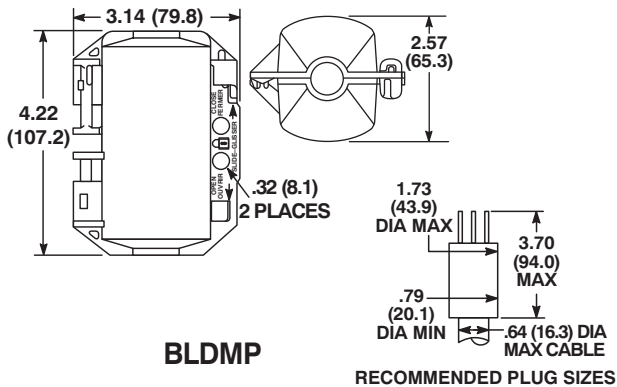

Wiring Devices – Technical Information

| Table III - Horsepower Ratings | | | |
|--------------------------------|-----------------|--------------------|----------------|
| NEMA Configuration | AC HP Rating** | Nema Configuration | AC HP Rating** |
| 1-15 | 0.5 | L1-15 | 0.5 |
| 2-15 | 1.5 | L2-20 | 2 |
| 2-20 | 2 | L5-15 | 0.5 |
| 2-30 | 2 | L5-20 | 1 |
| 5-15 | 0.5 | L5-30 | 2 |
| 5-20 | 1 | L6-15 | 1.5 |
| 5-30 | 2 | L6-20 | 2 |
| 5-50 | 2 | L6-30 | 2 |
| 6-15 | 1.5 | L7-15 | 2 |
| 6-20 | 2 | L7-20 | 2 |
| 6-30 | 2 | L7-30 | 3 |
| 6-50 | 3 | L8-20 | 3 |
| 7-15 | 2 | L8-30 | 5 |
| 7-20 | 2 | L10-20 | 2 L-L/1 L-N |
| 7-30 | 3 | L10-30 | 2 L-L/2 L-N |
| 7-50 | 5 | L11-15 | 2 |
| 10-20 | 2 L-L/1 L-N | L11-20 | 3 |
| 10-30 | 2 L-L/2 L-N | L11-30 | 3 |
| 10-50 | 3 L-L/2 L-N | L12-20 | 5 |
| 11-15 | 2 | L12-30 | 10 |
| 11-20 | 3 | L14-20 | 2 L-L/1 L-N |
| 11-30 | 3 | L14-30 | 2 L-L/2 L-N |
| 11-50 | 7.5 | L15-20 | 3 |
| 14-15 | 1.5 L-L/0.5 L-N | L15-30 | 3 |
| 14-20 | 2 L-L/1 L-N | L16-20 | 5 |
| 14-30 | 2 L-L/2 L-N | L16-30 | 10 |
| 14-50 | 3 L-L/2 L-N | L18-20 | 2 |
| 14-60 | 3 L-L/2 L-N | L18-30 | 3 |
| 15-15 | 2 | L19-20 | 5 |
| 15-20 | 3 | L19-30 | 10 |
| 15-30 | 3 | L21-20 | 2 |
| 15-50 | 7.5 | L21-30 | 3 |
| 15-60 | 10 | L22-20 | 5 |
| 18-15 | 2 | L22-30 | 10 |
| 18-20 | 2 | | |
| 18-30 | 3 | | |
| 18-50 | 7.5 | | |
| 18-60 | 7.5 | | |

**The phase-to-phase horsepower ratings are noted by "L-L". The phase-to-neutral ratings are identified by "L-N"

Wiring Devices - NEMA Configuration Chart

| Locking Style NEMA Configurations | | | | | |
|-----------------------------------|---------------------|--------|-------------------|---------------------|---------------------|
| | Voltage | NEMA # | 15 Ampere | 20 Ampere | 30 Ampere |
| | | | Receptacle/Plug | Receptacle/Plug | Receptacle/Plug |
| 2-Pole 3-Wire Grounding | 125V | L5 | L5-15R L5-15P | L5-20R L5-20P | L5-30R L5-30P |
| | 250V | L6 | L6-15R L6-15P | L6-20R L6-20P | L6-30R L6-30P |
| | 277V | L7 | L7-15R L7-15P | L7-20R L7-20P | L7-30R L7-30P |
| | 480V | L8 | | L8-20R L8-20P | L8-30R L8-30P |
| | 600V | L9 | | L9-20R L9-20P | L9-30R L9-30P |
| 3-Pole 4-Wire Grounding | 125/250V | L14 | | L14-20R L14-20P | L14-30R L14-30P |
| | 3 ϕ 250V | L15 | | L15-20R L15-20P | L15-30R L15-30P |
| | 3 ϕ 480V | L16 | | L16-20R L16-20P | L16-30R L16-30P |
| | 3 ϕ 600V | L17 | | | L17-30R L17-30P |
| 4-Pole 5-Wire Grounding | 3 ϕ Y 120/208V | L21 | | L21-20R L21-20P | L21-30R L21-30P |
| | 3 ϕ Y 277/480V | L22 | | L22-20R L22-20P | L22-30R L22-30P |

| Straight-Blade Style NEMA Configurations | | | | | |
|--|---------|--------|-----------------|-----------------|-----------------|
| | Voltage | NEMA # | 15 Ampere | 20 Ampere | 30 Ampere |
| | | | Receptacle/Plug | Receptacle/Plug | Receptacle/Plug |
| 2-Pole 3-Wire Grounding | 125V | 5 | 5-15R 5-15P | 5-20R 5-20P | 5-30R 5-30P |
| | 250V | 6 | 6-15R 6-15P | 6-20R 6-20P | 6-30R 6-30P |

Note: Please see Appendix for

- 1.) Mechanical and electrical properties of material data
- 2.) Chemical resistance of material
- 3.) Table III Hp rating chart

Wiring Devices – NEMA Wiring Diagrams

Reference material only. Please see Wiring Section in the catalog for product part number.

2-Pole 2-Wire

125V

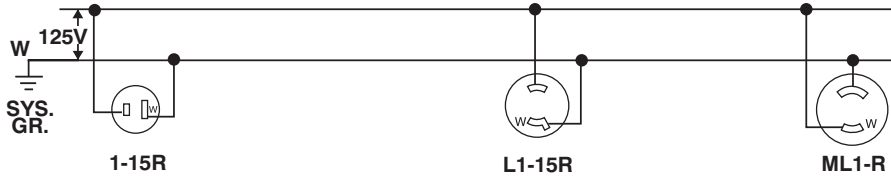

208V or 250V

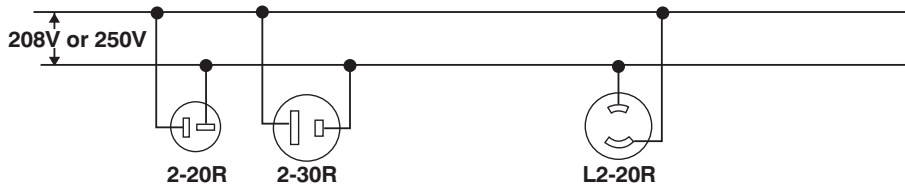

2-Pole 3-Wire Grounding

125V

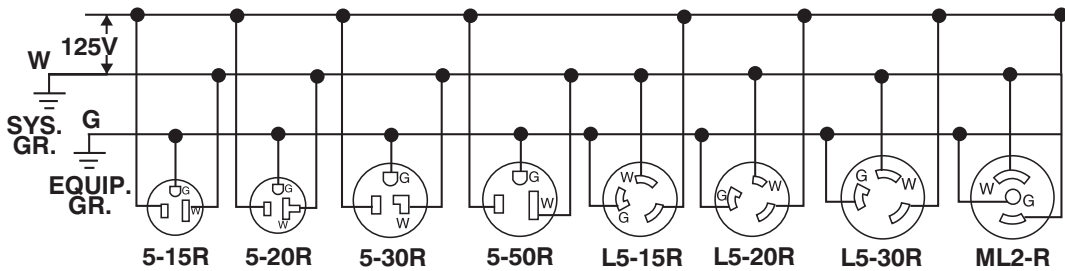

208V or 250V

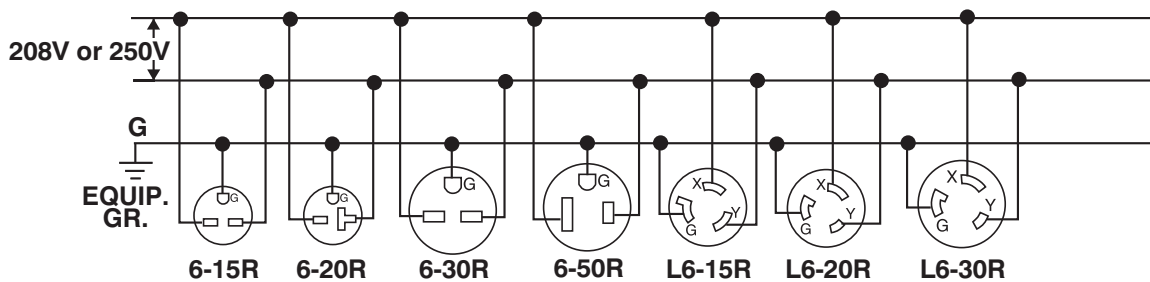

277V AC

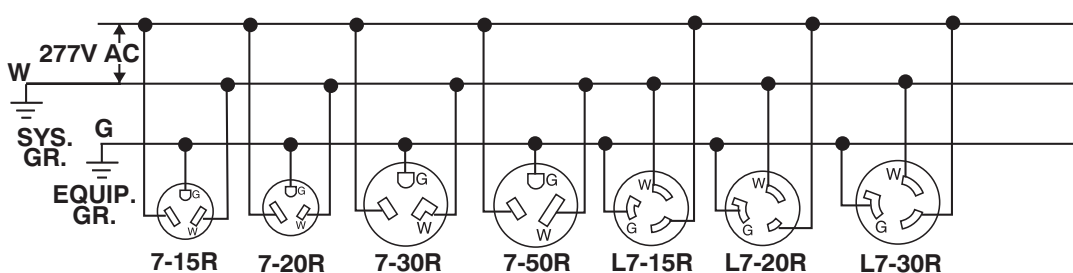

Wiring Devices – NEMA Wiring Diagrams

2-Pole 3-Wire Grounding

480V AC

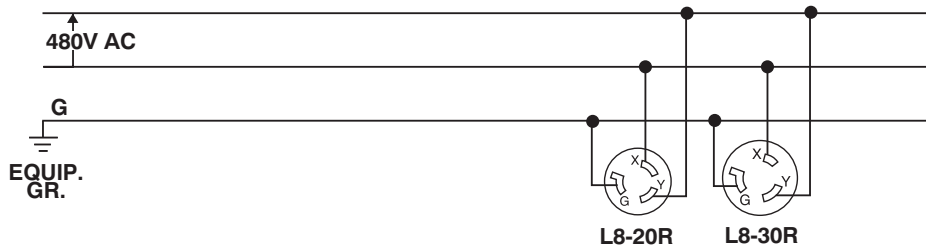

600V AC

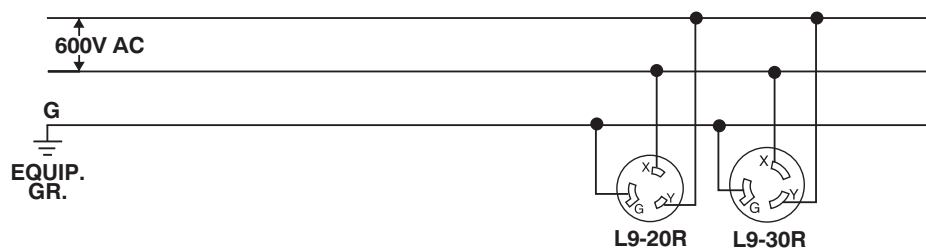

3-Pole 3-Wire

125V/250V AC

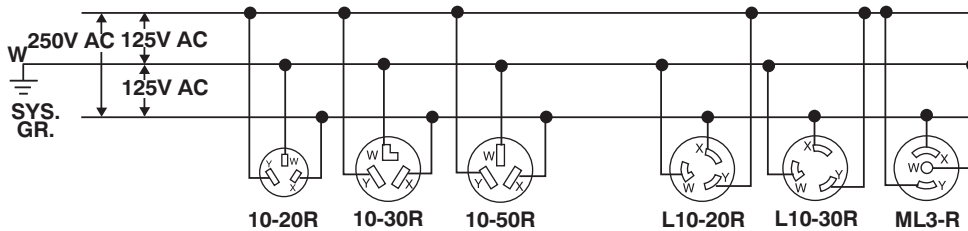

3 ϕ 250V AC

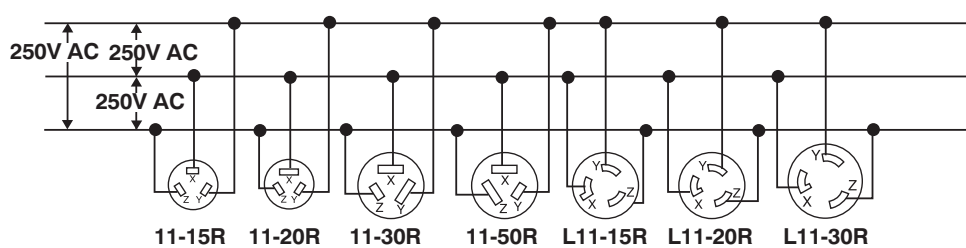

3 ϕ 480V AC

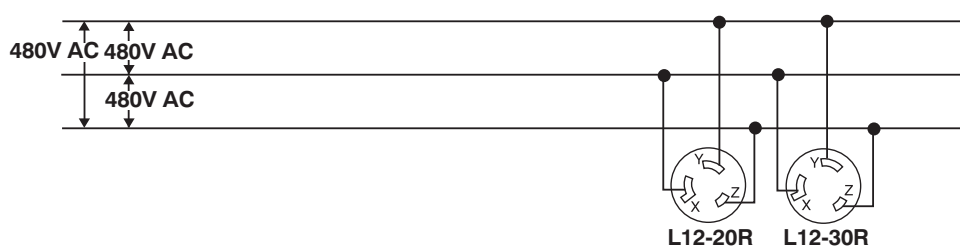

Wiring Devices – NEMA Wiring Diagrams

3-Pole 3-Wire Continued

3 ϕ 600V AC

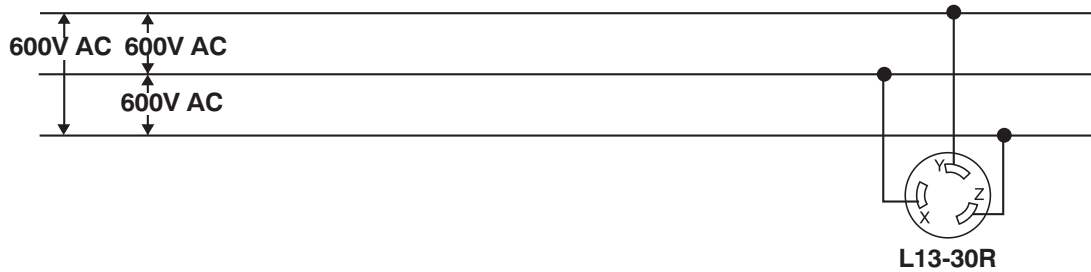

3-Pole 4-Wire Grounding

125/250V AC

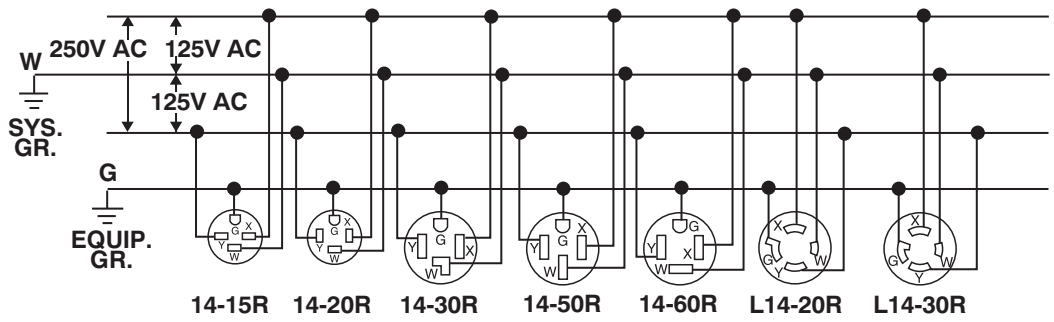

3 ϕ 250V AC

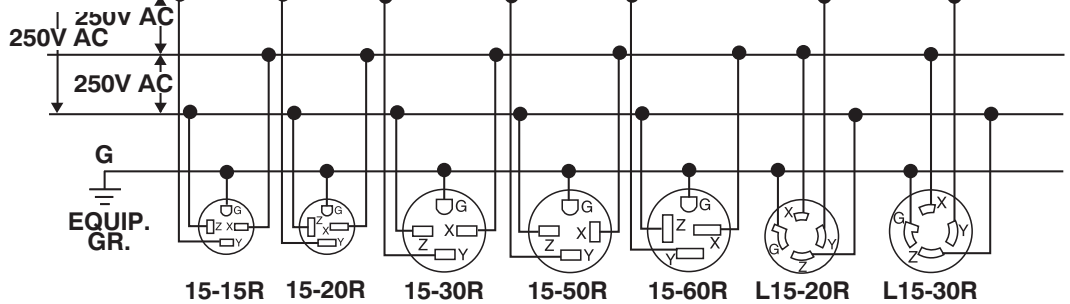

3 ϕ 480V AC

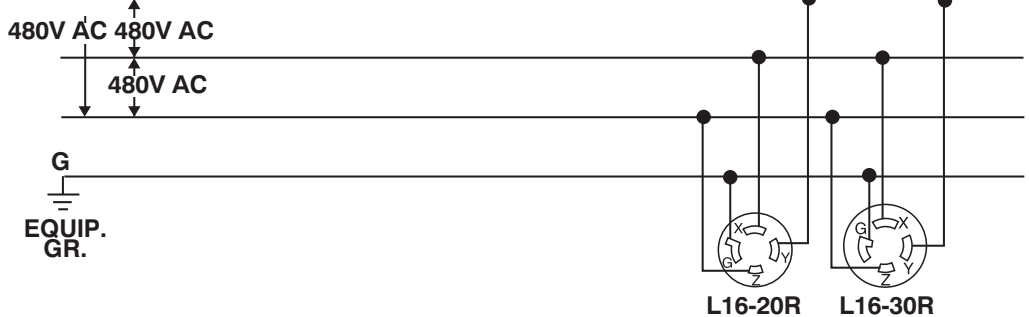

Wiring Devices – NEMA Wiring Diagrams

3-Pole 4-Wire Grounding Continued

3 ϕ 600V AC

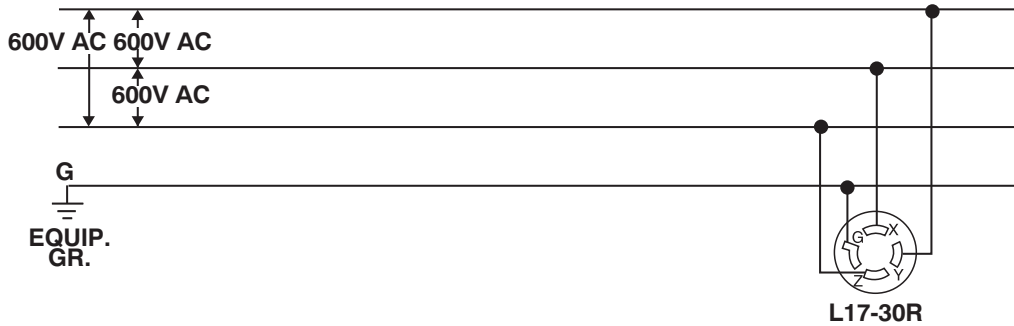

4-Pole 4-Wire

3 ϕ Y 120/208V AC

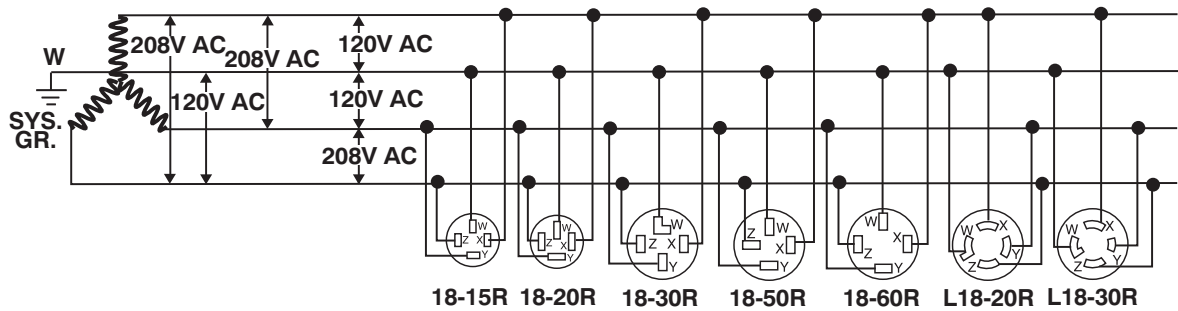

3 ϕ Y 277/480V AC

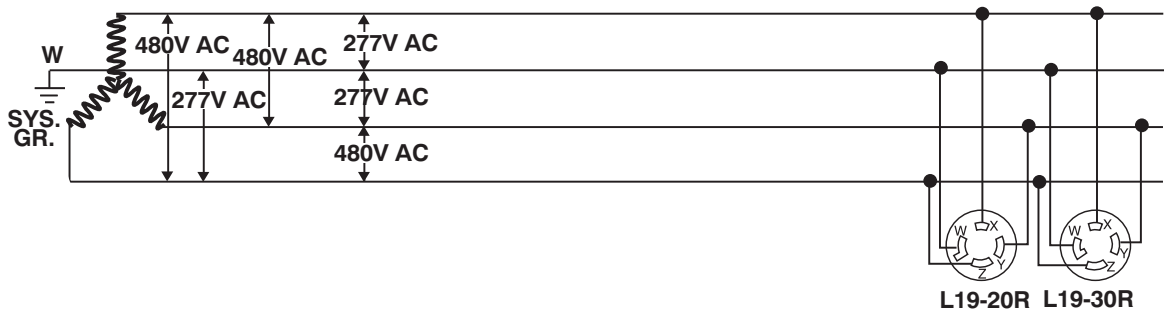

3 ϕ Y 347/600V AC

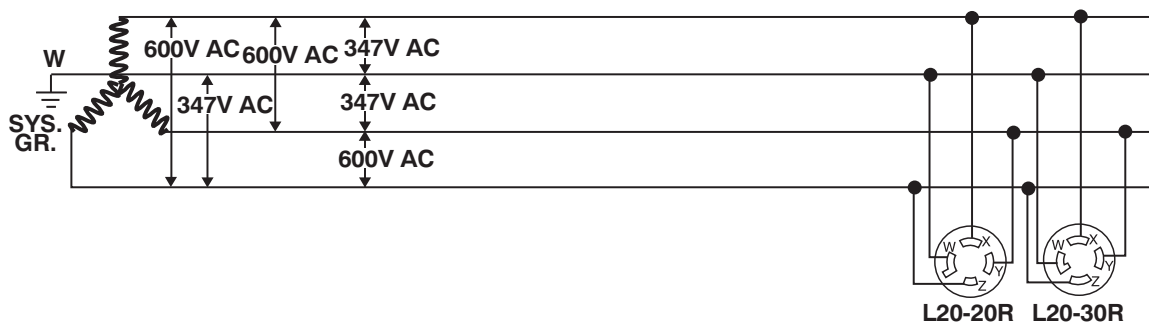

Wiring Devices – NEMA Wiring Diagrams

4-Pole 5-Wire Grounding

3 ϕ Y 120/208V AC

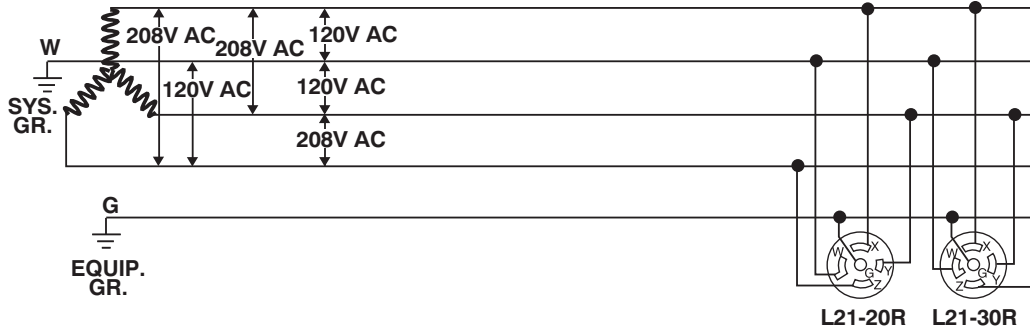

3 ϕ Y 277/480V AC

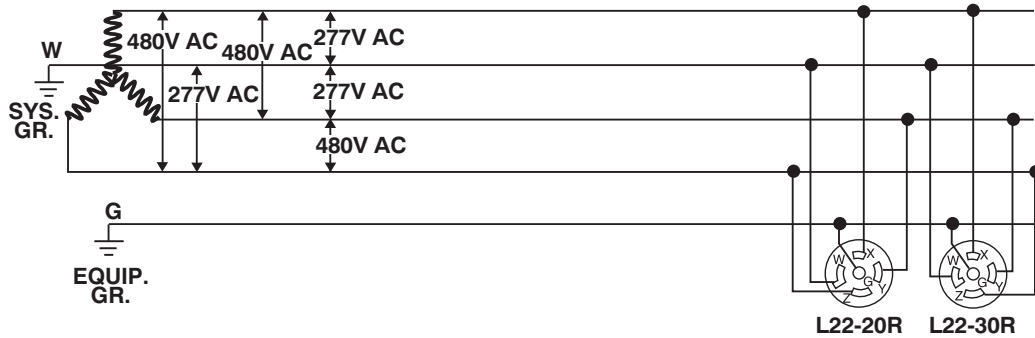

3 ϕ Y 347/600V AC

