

DL305
Programmable
Logic Controllers
(PLC)

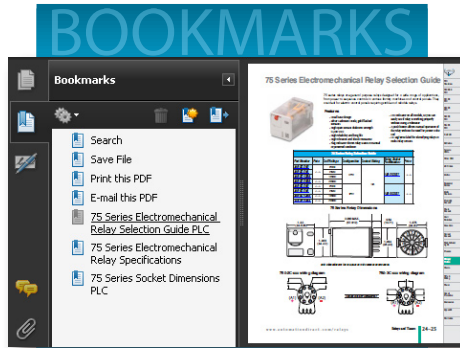

In this interactive PDF you can:

- Use bookmarks to navigate by product category
- Use bookmarks to save, search, print or e-mail the catalog section
- Click on part #s to link directly to our online store for current pricing, specs, stocking information and more

Up-to-date price list:
www.automationdirect.com/pricelist

FREE Technical Support:
www.automationdirect.com/support

FREE Videos:
www.automationdirect.com/videos

FREE Documentation:
www.automationdirect.com/documentation

FREE CAD drawings:
www.automationdirect.com/cad

Company Information

Control Systems Overview

CLICK PLC

Do-More PLCs Overview

Do-More H2 PLC

Do-More T1H PLC

Direct.LOGIC PLCs Overview

Direct.LOGIC DL05/06

Direct.LOGIC DL105

Direct.LOGIC DL205

Direct.LOGIC DL305

Direct.LOGIC DL405

Productivity Controller Overview

Productivity 3000

Universal Field I/O

Software

C-More HMI

C-More Micro HMI

ViewMarq Industrial Marquees

Other HMI

Communications

Appendix Book 1

Terms and Conditions



DL305 - Still supports all these PLCs

What is it?

The DL305 series is a small modular PLC that has been marketed by various name-brand PLC manufacturers for over 31 years. This Koyo design revolutionized the small PLC market, and is still going strong in tens of thousands of installations. You can maintain your current system with fully compatible replacement modules.

What's it got?

- Three standard CPUs, including the D3-350 with PID control and two communication ports
- Specialty CPUs to convert a DL305 system into an RTU for Optomux, Pamux, or to allow BASIC programming for custom applications
- 5, 8 and 10-slot bases
- 110/220VAC or 24VDC power supply
- AC, DC inputs
- AC, DC, and relay outputs
- 8 or 12-bit analog input/output
- Specialty modules such as high-speed counter, and communication interface module (work with D3-330 and D3-340 CPUs)

What can I do with it?

- Maintain or upgrade any installed GE Series One, Texas Instruments Series 305, or Siemens SIMATIC TI305 system

You can swap parts among all the PLCs on the opposite page

The DL305 PLC design has offered exceptional reliability, the right mix of features and a great price. This design was so well-liked when it was introduced that it became the most popular privately-labeled PLC in history. Best of all, almost every part produced in its 31-year history is interchangeable.

GE nicknamed it “America’s Most Popular PLC”

In 1983, General Electric decided to private label the Koyo SR21 design. They called it the General Electric Series One and changed the color from Koyo yellow to black. The product sold so well they nicknamed it “America’s Most Popular PLC.”

Texas Instruments called it the “Best Value PLC”

In 1989, Texas Instruments began to private label the Koyo SR21 design. They named it the Series 305 and changed the plastic color to light gray. The product was enhanced and did so well for Texas Instruments that they nicknamed it the “Best Value PLC.”

Siemens also called it the “Best Value PLC”

In 1991, Siemens Industrial Automation decided to private label the Koyo SR21 design. They named it the SIMATIC TI305 and changed the color to charcoal grey. Once again, the product line continued to receive enhancements and the nickname “Best Value PLC” continued at Siemens.

AutomationDirect calls it a “PLC Classic”

In 1994, AUTOMATIONDIRECT added more enhancements with Windows-based *DirectSOFT*, and in 1997 introduced the D3-350 CPU, which offered updated features while maintaining compatibility with legacy systems.

The DL305 has served well; however, if you are designing a new system, we encourage you to review our latest PLCs with much easier configuration and a more intuitive instruction set - CLICK, Do-more or Productivity series controllers.



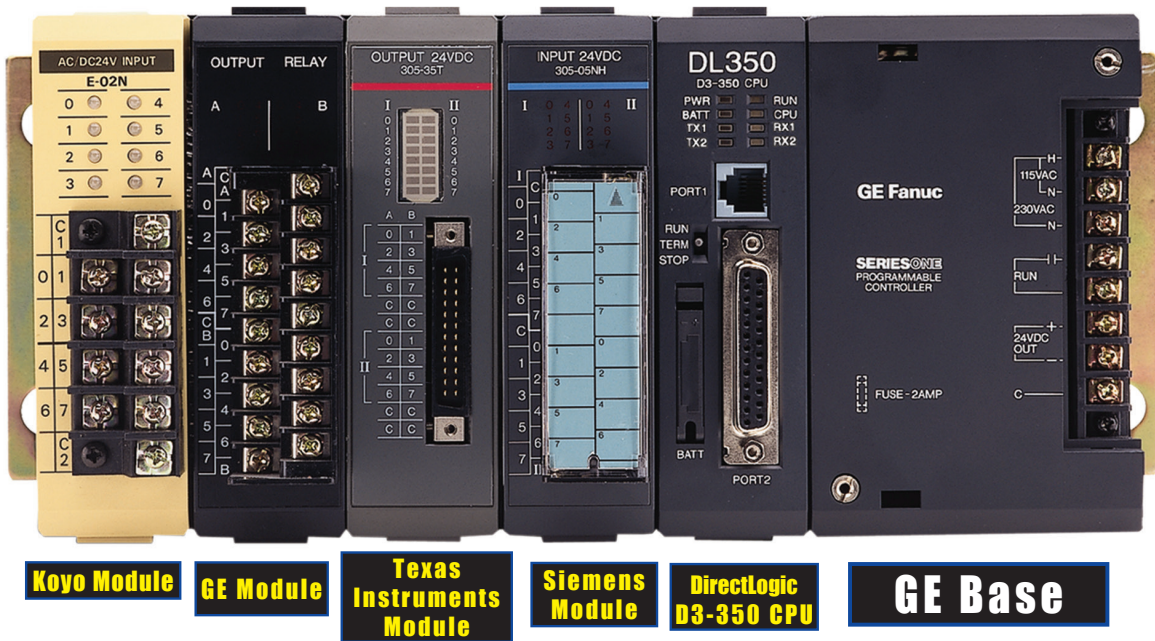

DL305 PLC CPU Features	D3-330	D3-340	D3-350
Memory (words)	3.7K	3.7K	14.8K
Local I/O	176	184	368
Remote I/O	NO	NO	512**
RS-232C ports	1*	2	2
Network master	NO	YES	YES
MODBUS RTU	NO	Slave	Master/slave
Built-in remote I/O	NO	NO	YES
Real-time clock	NO	NO	YES
PID	NO	NO	YES
Floating-point math	NO	NO	YES
Drum timers	NO	NO	YES
Price	\$459.00	\$631.00	\$551.00

*D3-DCU required **Uses DL205 and DL405 remote slaves
Prices as of 4/18/16

Order online or call 1-800-633-0405 for replacement modules
Maintain or upgrade any installed GE Series One, Texas Instruments Series 305, or Siemens SIMATIC TI305 system



DL305 Family of Products

DL305 system example with serial communications network and operator interface

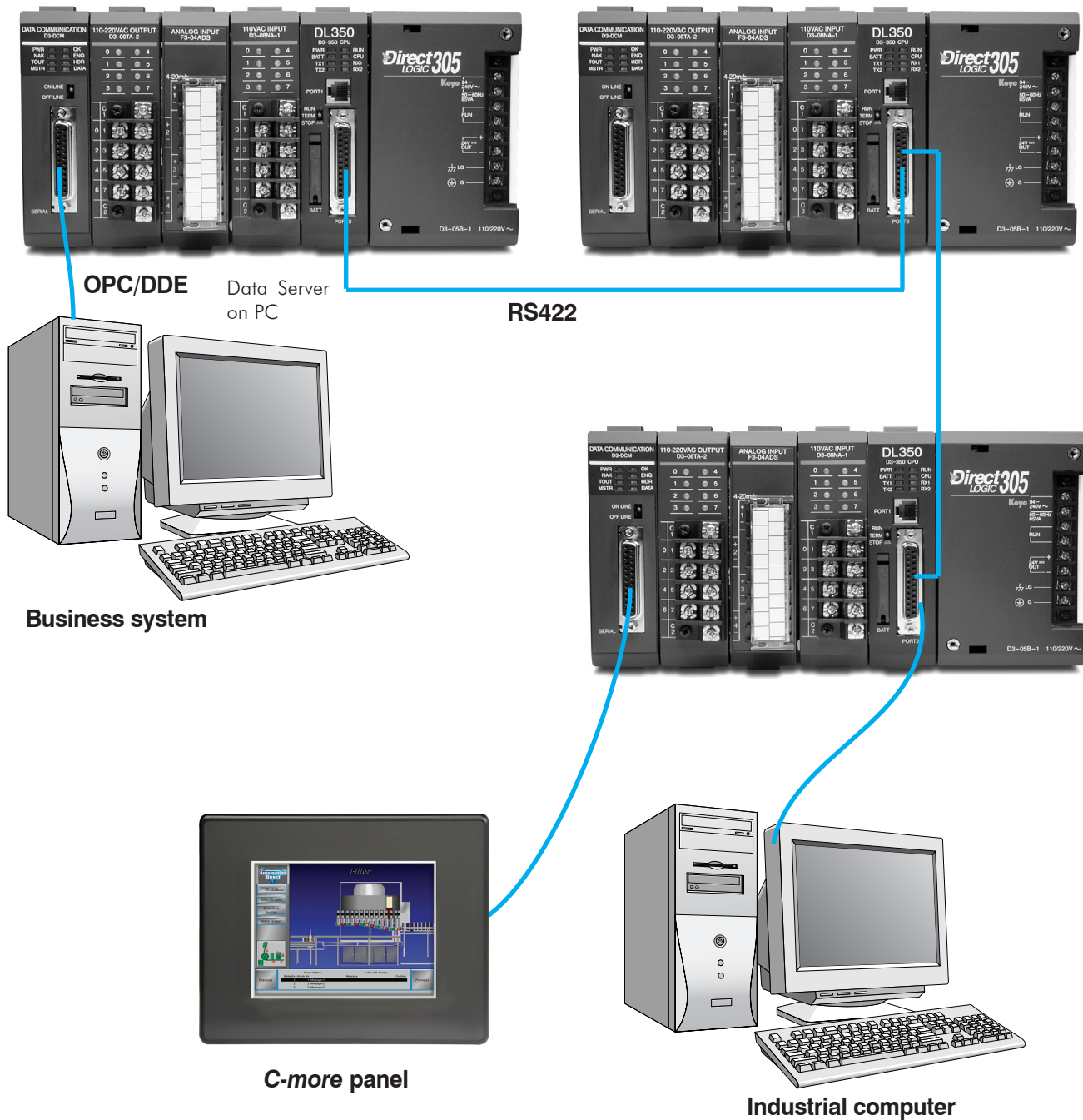

DL305 Family of Products

The following is a quick summary of the DL305 family of products. The DL305 products have been sold by previous vendors under a wide variety of part numbers. A complete list of product offerings with vendor cross-reference is available in the DL305 price list.

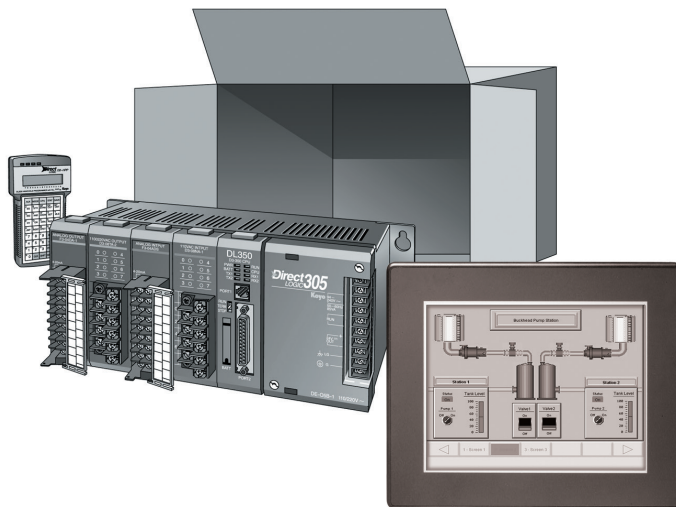

CPUs

- D3-350 – 14.8K total memory
- 2 communication ports
- 4 PID loops
- MODBUS Master/Slave
- Remote I/O
- Floating point math
- D3-340 – 3.7K total memory
- 2 communication ports
- D3-330 – 3.7 K total memory

Specialty CPUs

- F3-0MUX-1
- Serial interface to Optomux host
- 2 communication ports (RS232C/422/485) selectable
- F3-0MUX-2
- Serial interface to Optomux host
- 2 communication ports (RS422/485)
- F3-PMUX-1
- Parallel interface to Pamux host

Bases

- 5-slot local or expansion base
- Built-in 110/220 VAC power supply
- 5-slot local or expansion base
- Built-in 24 VDC power supply
- 8-slot local base (exp. base w/350 CPU)
- Built-in 110/220 VAC power supply
- 10-slot local or expansion base
- Built-in 110/220 VAC power supply
- 10-slot local or exp. base
- Built-in 24 VDC power supply

Discrete input modules

- DC Input
- 8-pt. 24VDC source
- 16-pt. 24VDC source
- 16-pt. 5V/12-24VDC (sink/source, 1ms response)

- AC Input
- 8-pt. 110/220VAC
- 16-pt. 110 VAC

- AC/DC Input
- 8-pt. 24VAC/DC
- 16-pt. 24VAC/DC

Discrete output modules

- DC Output
- 4-pt. 5-24VDC sink
- 8-pt. 5-24VDC sink
- 8-pt. 5-24VDC source
- 16-pt. 5-24VDC sink
- 16-pt. 5-24VDC source
- AC Output
- 4-pt. 110-220VAC isolated
- 8-pt. 110VAC isolated
- 8-pt. 110-220VAC isolated
- 16-pt. 15-220VAC

- RELAY Output
- 8-pt. 5.0A/pt
- 8-pt. 4.0A/pt isolated
- 8-pt. 10.0A/pt isolated
- 16-pt. 2A/pt

Analog modules

- 4 Channel IN, 12 bit, isolated
- 8 Channel IN, 12 bit
- 8 Channel thermocouple
- 16 Channel IN, 12 bit
- 4 Channel OUT 12 bit
- 4 Channel OUT 12 bit (isolated)

Specialty modules

- 8 pt. Input Simulator
- Filler Module

Programming

- D3-HP Handheld Programmer for D3-330/D3-340
- D2-HPP Handheld Programmer with built-in RLL PLUS for D3-350
- DirectSOFT Programming for Windows (PC-DSOFT6)**

DIN rail mounted terminal blocks

See the Connection Systems section for over 200 available options.

Communications

- Data Comm Unit (RS232C), 330/340 CPUs only
- Data Comm Unit (RS422), 330/340 CPUs only
- Data Comm Module, 350 CPU only

Operator panels

See the Operator Interface section for a complete listing of all types of panels and software.

Connection systems

See the Wiring Solutions section in this catalog for information on DINector terminal blocks, ZIPLink connection systems and other connection accessories for use with the DL305 system.

Company Information

Control Systems Overview

CLICK PLC

Do-More PLCs Overview

Do-More H2 PLC

Do-More T1H PLC

DirectLOGIC PLCs Overview

DirectLOGIC DL05/06

DirectLOGIC DL105

DirectLOGIC DL205

DirectLOGIC DL305

DirectLOGIC DL405

Productivity Controller Overview

Productivity 3000

Universal Field I/O

Software

C-More HMI

C-More Micro HMI

ViewMarq Industrial Marquees

Other HMI

Communications

Appendix Book 1

Terms and Conditions

DL305 CPUs

There are three conventional CPUs and three specialty CPUs in the DL305 family. There are many considerations for choosing the right CPU, most of which depend on your particular application. The traditional CPUs, which offer control via RLL-style programming, are great for most applications. The information in this section provides a quick comparison. If you need to control I/O with a personal computer, or if you want to run a BASIC program in a CPU instead of ladder logic, then check out the specialty CPUs.

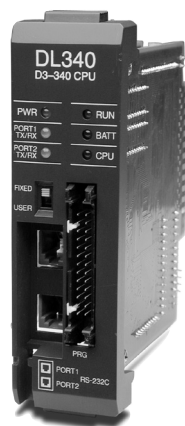
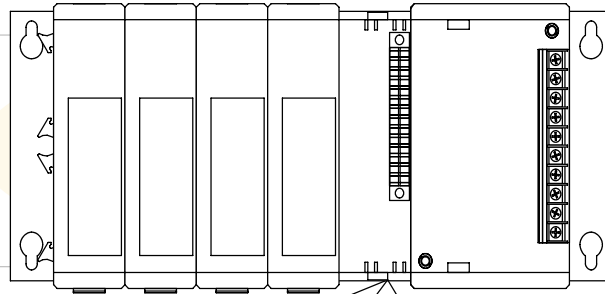

D3-330—The D3-330 design has been very popular for many years. It offers the lowest-cost solution in the DL305 family. It is great for machines that need little (if any) communications between the CPU and other devices.

D3-340—The D3-340 offers a faster scan rate, two RS232C ports (one with built-in Modbus RTU slave) and additional I/O points. Need RS422? Simply add an FA-ISOCAN converter to one of the ports. If you need built-in communications, or even just an extra 16-point I/O card, the D3-340 offers the lowest-cost solution. This CPU allows you to make the most of your investment in a DL305 (or compatible) system.

D3-350—The D3-350 is the most powerful DL305 CPU. It is a spin-off of the D4-450 and D2-250(-1). It is plug-compatible with older bases, as well as the instruction set and I/O numbering scheme are similar to our DL05, DL06, DL105, DL205 and DL405 PLCs. The communications capabilities have also been greatly enhanced to include RS422 Remote I/O, MODBUS Master and Slave protocols, as well as our own *DirectNet* and K-Sequence protocols. When the D3-350 is installed in a -1 base, even more features are available. These bases allow for greater I/O expansion capabilities and for intelligent I/O modules.

NOTE: D3-330 and D3-340 programs cannot be downloaded into the D3-350 CPU. The D3-350's instruction set is based on the DL205/DL405 instruction set. If an existing D3-330 or D3-340 system is upgraded to a D3-350 CPU, the RLL program must be re-written for the D3-350 CPU.

Programming

Handheld programmer...D2-HPP	\$321.00
<i>DirectSOFT</i> Programming for Windows	
PC-DSOFT6	\$395.00
PC-DS100	Free
PC-R60-U (upgrade)	\$179.00

CPU Specifications

DL305 CPU Specifications			
System Capacity	D3-330	D3-340	D3-350
Total memory (K words)	3.91	3.98	14.8
Ladder memory (K words)	3.7	3.7	7.6
User data memory	116 bytes	172 bytes	7.1K words
CMOS RAM	Yes	Yes	No
UVPROM	Opt.	Opt.	No
EEPROM	No	Opt.	Flash
Total I/O points using:			
Local I/O	128	136	144
Local and Expansion I/O	176	184	368
Remote I/O ¹	N/A	N/A	512
I/O point density	8/16	8/16	8/16
Slots per base (CPU requires 1 slot)	5/8/10	5/8/10	5/8/10
Performance			
Contact execution (boolean)	6.6µs	.87µs	.61µs
Typical scan (1K boolean) ²	15ms	4-5ms	5-6ms
Programming & Diagnostics			
RLL ladder style	Yes	Yes	Yes
RLL ^{PLUS} (stage)	No	No	Yes
RunTime Editing	No	No	Yes
Supports Overrides	No	No	Yes
Variable/fixed scan	variable	variable	either
Handheld programmer port	Yes	Yes	Yes
Built-in RS232C ports	No ³	2	2
Real-time clock/calendar	No	No	Yes
Instructions	61	63	129
Control relays(CR)	140	196	1024
Shift register bits	128	128	use CRs
Stages (RLL ^{PLUS} only)	N/A	N/A	1024
Timers/counters	64	64	256/128
Immediate I/O	No	No	Yes
Subroutines	No	No	Yes
For/Next Loops	No	No	Yes
Timed interrupt	No	No	Yes
Integer math	Yes	Yes	Yes
Floating point math	No	No	Yes
PID	No	No	Yes
Drum sequence	No	No	Yes
Bit of word	No	No	Yes
ASCII print	No	No	Yes
Data registers	128	192	7168
Internal diagnostics	Yes	Yes	Yes
Password security	Yes	Yes	Multi-level
Battery backup	Yes	Yes	Yes
Communications			
Built-in ports ³	No	Yes	Yes
DirectNET master	No	Yes	Yes
DirectNET slave	w/DCU	Yes	Yes
MODBUS RTU master	No	No	Yes
MODBUS RTU slave	No	Yes	Yes
Data communications unit	Yes	Yes	N/A
Specialty modules			
Thermocouple	Yes	Yes	Yes
Analog Input (#channels max.)	112	128	368
Analog output (#channels max.)	28	32	48
High-speed counter (10KHz)	Yes	Yes	No

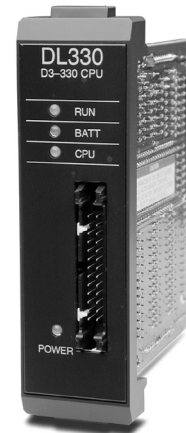

1. The D3-350 bottom port supports DL205 remote I/O.
2. 1K program includes contacts, coils, and scan overhead. If you compare to other products, make sure to include their scan overhead.
3. The D3-330 requires a Data Communications Unit (DCU) for programming with DirectSOFT software.

Company Information

Control Systems Overview

CLICK PLC

Do-More PLCs Overview

Do-More H2 PLC

Do-More T1H PLC

DirectLOGIC PLCs Overview

DirectLOGIC DL05/06

DirectLOGIC DL105

DirectLOGIC DL205

DirectLOGIC DL305

DirectLOGIC DL405

Productivity Controller Overview

Productivity 3000

Universal Field I/O

Software

C-More HMI

C-More Micro HMI

ViewMarq Industrial Marquees

Other HMI

Communications

Appendix Book 1

Terms and Conditions

D3-350 CPU

D3-350 \$551.00

Our most powerful DL305 CPU

The D3-350 combines the power, speed and ease of the D2-250-1 CPU with existing DL305 I/O modules and bases.

DirectSOFT Programming Software Release V2.3 or higher is required to program the D3-350. For existing license holders, an upgrade package is available. If you are using a handheld programmer (D2-HPP, release 1.8 or lower), a new release of handheld programmer firmware will also be required.

Four PID loops and auto-tuning

The D3-350 CPU can process up to four PID loops directly in the CPU. Select from various control modes, including automatic, manual and cascade control. There are a wide variety of alarms including Process Variable, Rate of Change and Deviation. The loop operation parameters (Process Variable, Setpoint, Setpoint Limits, etc.) are stored in V-memory, which allows easy access from operator interfaces or HMIs.

Setup is accomplished with easy-to-use setup menus and monitoring views in our *DirectSOFT* Programming Software.

The auto-tuning feature is also easy to use and can reduce setup and maintenance time. The CPU uses the auto-tuning feature to automatically determine near optimum loop settings.

Note: D3-330 and D3-340 programs cannot be downloaded into the D3-350 CPU. The D3-350's instruction set is based on the DL205/DL405 instruction set. If an existing D3-330 or D3-340 system is upgraded to a D3-350 CPU, the RLL program must be re-written for the D3-350 CPU.



Powerful built-in CPU communications

The D3-350 offers two communication ports that provide a vast array of communication possibilities. The top RS232C port is for programming, a DV-1000 connection, a connection to our operator interface panels, or a K-sequence/*DirectNET* slave port. The 25-pin bottom port can use RS232C or RS422. This port offers several different protocol options, such as K-sequence protocol, *DirectNET* Master/Slave, Modbus Master/Slave, and even a direct connection to DL205 remote I/O. The ability to select these features is provided via software so you can choose the best combination for the application.

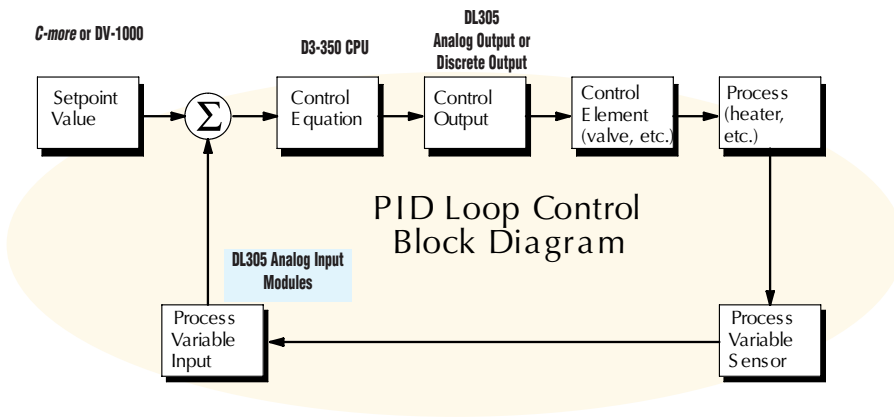
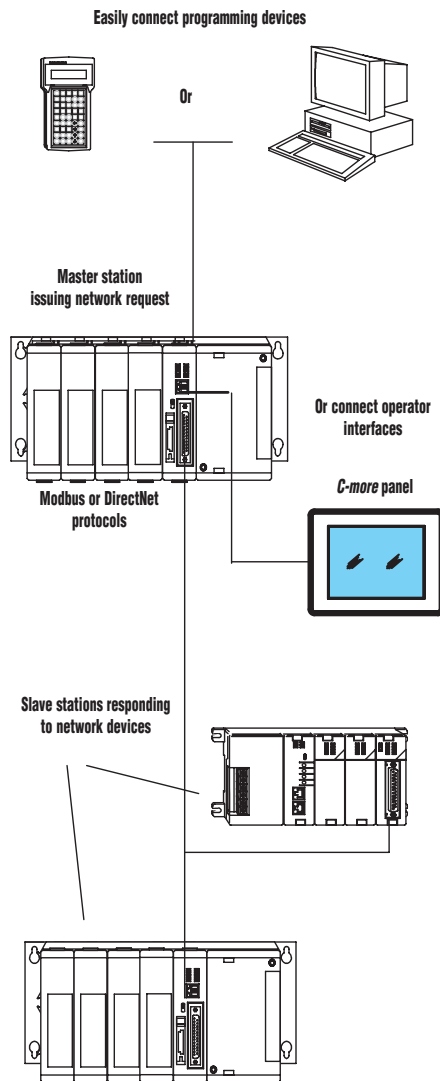

D3-350 Key Features

The D3-350 supports over 130 instructions. These include:

- Four types of drum sequencers
- Leading and trailing edge triggered one-shots
- Bit of word manipulation
- Floating point conversions
- Print instruction to send ASCII data through the bottom CPU port

For a complete list of instructions supported by the D3-350 CPU, see the end of this section.

On-board flash memory

The D3-350 has 7.6 K of flash memory on board. With flash memory, you don't have to worry about losing the program due to a bad battery. If you have critical data stored in V-memory, like PID loops, simply purchase the optional lithium battery to maintain these parameters as well.

Built-in remote I/O connection

The bottom port on the D3-350 can also be used as a master for a remote I/O network.

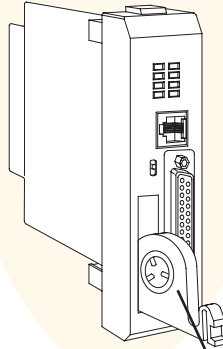
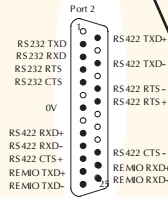
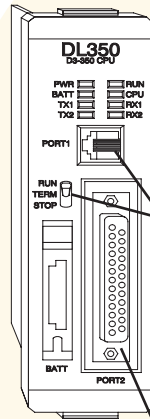

CPU Status Indicators		
RUN	ON	CPU is in RUN mode
	OFF	CPU is in Program mode
BATT	ON	Battery backup voltage is low
	OFF	Battery backup voltage is OK or disabled
CPU	ON	CPU internal diagnostics has detected an error
	OFF	CPU is OK
PWR	ON	CPU power good
	OFF	CPU power failure
Mode Switch		
RUN	Forces CPU into Run Mode	
TERM	Allows peripherals (HPP, <i>DirectSOFT</i> and operator interface panels) to write to the CPU.	
STOP	Forces CPU out of RUN mode	
Port 1		
Protocols	K-sequence slave <i>DirectNET</i> slave	
	Devices Can connect w/HPP, <i>DirectSOFT</i> , DV-1000, <i>C-more</i> Panels, or any <i>DirectNET</i> Master	
Specs.	6P6C phone jack connector RS232C 9600 baud Odd parity Fixed station address 1 8 data bits 1 start, 1 stop bit Asynchronous, half-duplex, DTE	
	Port 2	
Protocols	K-sequence slave <i>DirectNET</i> Master/slave MODBUS RTU Master/slave Remote I/O Master	
	Devices Can connect w/many devices, such as PCs running <i>DirectSOFT</i> , <i>KEPdirect</i> for PLCs Server, HMI packages, DV-1000, <i>C-more</i> panels, or any <i>DirectNET</i> or MODBUS RTU master or slave	
	Specs. 25-pin D-shell connector RS232C/RS422 300/600/1200/2400/4800/9600 19.2K/38.4K Baud Odd, even or no parity Selectable address (1-90, HEX 1-5A) 8 data bits-1 start, 1 stop bit Asynchronous, half-duplex, DTE	
Batteries (optional)		
D2-BAT-1	D3-350 only, coin type 3.0V Lithium battery, 560mA battery # CR2354	

Note: Batteries are not needed for program backup. However, you should order a battery if you have parameters in V-memory that must be maintained in case of a power outage, such as PID loops.

D3-350 PID Loop Specifications

PID Loop Specifications and Key Features	
Number of Loops	Selectable, four maximum
CPU V-Memory Required	32 V-memory locations per loop selected (additional 32 V-memory locations per loop required if using Ramp/Soak)
PID Algorithm	Position or velocity form of the PID equation. direct or reverse acting, square root of the error and error squared control.
Auto Tuning	Open-loop step response method and closed-loop limit cycle method.
Sample Rate	Specify the time interval between PV samples, 0.05 to 99.99 seconds. Smallest sample rate is limited to either 0.05 seconds or (PLC scan time x number of loops).
Loop Operation Modes	Loops can be in automatic control, manual (operator) control, or cascade control. PV alarm monitoring continues when loops are in manual mode.
Ramp/Soak	Up to 16 steps (8 ramp, 8 soak) per loop, with indication of ramp/soak step.
Square Root PV	Specify a Square root of the PV for a flow control application.
Limit SP	Specify a maximum and minimum value for allowable setpoint changes.
Limit Output	Specify a maximum and minimum value for the output range.
Gain	Specify proportional gain of 0.01 to 99.99.
Reset	Specify integral time of 0.1 to 999.8 in units of seconds or minutes.
Rate	Specify the derivative time, 0.00 to 99.99 seconds.
Rate Limiting	Specify a derivative gain limiting coefficient to filter the PV used in calculating the derivative term (0 to 20).
Bumpless Transfer I	Bias and setpoint are initialized automatically when the module is switched from manual to automatic. This provides for a bumpless transfer, which reduces the chance of sharp changes in the output as a result of entering automatic mode.
Bumpless Transfer II	Bias is set equal to the output when the module is switched from manual to automatic. This allows switching in and out of automatic mode without having to re-enter the setpoint.
Error Deadband	Specify an incremental value above and below the setpoint in which no change in output is made.
Error Squared	Squaring the error minimizes the effect a small error has on the Loop output, however both Error Squared and Error Deadband control may be enabled.
Alarm Specifications	
Deadband	Specify 0.1% to 5% alarm deadband on all alarms except rate of change.
PV Alarm Points	Specify PV alarm settings for low-low, low, high, and high-high conditions. You can also specify a deadband to minimize the alarm cycles when the PV approaches alarm limits.
PV Deviation	Specify alarms to indicate two ranges of PV deviation from the setpoint value (yellow and red deviation).
Rate-of-Change	Specify a rate-of-change limit for the PV.

D3-330 and D3-340 Key Features

D3-330 \$459.00
D3-340 \$631.00

The diagram to the right shows the various hardware features found on the D3-330 and D3-340 CPUs.

CPU Status Indicators		
RUN	ON OFF	CPU is in RUN mode CPU is in Program mode
BATT	ON OFF	Memory backup voltage low Memory backup voltage good
CPU	ON OFF	CPU failure CPU is good
PWR (Power)	ON OFF	CPU power good CPU power failure
Port1 RX/TX (D3-340)	RED GREEN	Flashing red indicates the CPU port is receiving data Flashing green indicates the CPU port is sending data
Port2 RX/TX (D3-340)	RED Green	Flashing red indicates the CPU port is receiving data Flashing green indicates the CPU port is sending data

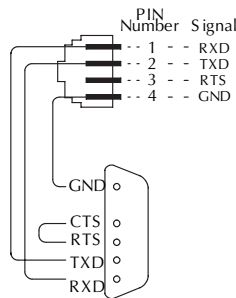
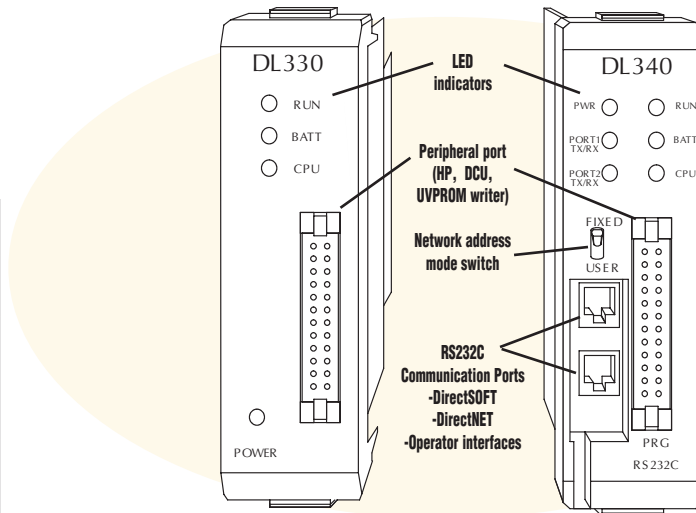

D3-340 RS232C Communication Port Specs	
Protocol	DirectNET
Connector	RJ11(handset connector)
Network address	01 to 90
Baud rate	38400, 19200, 9600, 4800, 2400, 1200, 600, 300
Parity-	None or odd
Transfer mode	HEX/ASCII Half-duplex Asynchronous
Data bits	8
Start bits	1
Stop bits	1
Turn around delay	0 to 1980 in 20ms intervals (preset with R777)

EEPROM and UVPROM chips

The DL305 CPUs come with on-board RAM and a battery. If you need additional program security, you may want to choose the EEPROM or UVPROM memory.

D3-CPU-UV \$148.00 Optional UVPROM memory. Four chips per pack. (Only one chip is required for the CPU.) A D3-PWU Prom Writer Unit is required for programming.

D3-340-EE \$171.00

Optional EEPROM memory for the D3-340 only. Four chips per pack. (Only one chip is required for the CPU.) No additional programming device is necessary.

D3-D4-BAT \$54.00

Spare battery (lithium 3.0V). Also used for D4-430 and D4-440 CPUs.

Hardware switches

Below is a side view of a D3-340 CPU that shows several types of hardware switches.

The D3-330 has a 2-position dipswitch for selecting retentive memory and jumpers for selecting UVPROM and RAM options.

The D3-340 has a jumper switch for selecting UVPROM, EEPROM and RAM options, two rotary switches to select network addresses and an eight-position dipswitch for selecting baud rates (300 to 38.4K baud), communication mode (slave, master, Modbus RTU) and memory options.

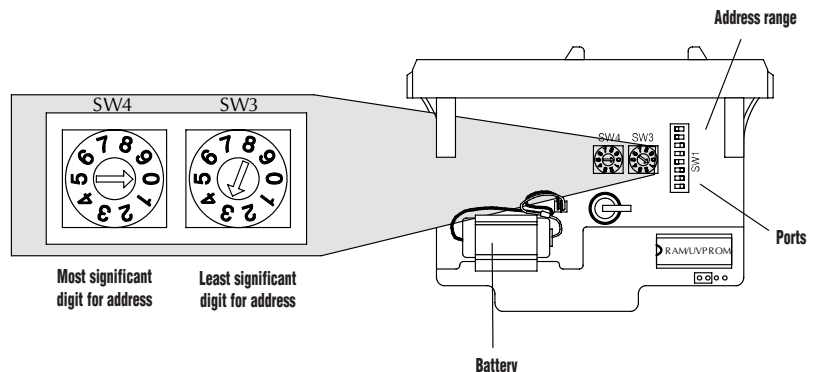

DL305 Specialty CPUs

Your application may require an unconventional PLC solution. For instance, you may need computer-controlled I/O (the PLC I/O is controlled directly by your personal computer), or maybe you would like a PLC that executes a control program written entirely in BASIC instead of RLL. AUTOMATIONDIRECT offers three specialty CPUs that provide solutions for each of these applications.

Computer I/O CPUs

Three CPUs are available for the DL305 family that allow DL305 I/O (with DL305 bases) to function as computer-controlled I/O. These CPUs (F3-OMUX-1, F3-OMUX-2 and the F3-PMUX-1) are similar in functionality, but offer different communication options. Each CPU allows DL305 modules of most types (see restrictions on types) to be interfaced with a host computer. The entire control program for the DL305 I/O is executed on the host computer, which uses an OPTOMUX or PAMUX driver.

The following charts show the various features found on the DL305 specialty CPUs:

F3-OMUX-n

Communication port specifications

Interface	F3-OMUX-1: RS232C/422 F3-OMUX-2: RS422/485 (isolated)
Connector	Two 9-pin D-sub sockets (female)
Baud Rate	Port 1: 300, 1200, 2400, 4800, 9600, 9200, 38400, 57600, 115200 Port 2: 9600
Protocol	OPTO 22 serial communications

F3-PMUX-1

Communication port specifications

Interface	Parallel
Connector	50-pin ribbon cable connector
Protocol	OPTO 22 parallel communications

I/O module restrictions

The specialty CPUs can make use of almost all DL305 modules, but they do not support the D3-HSC, or D3-02DA modules. These modules can only be used with the regular CPUs (D3-330 and D3-340).

F3-OMUX-1 \$519.00
F3-OMUX-2 \$509.00

The F3-OMUX (-1, -2) CPU plugs into the first slot of a DL305 base. It acts as a serial interface to the control program in the host computer and up to 184 DL305 I/O per CPU. Multiple CPUs can be daisy-chained together to increase I/O count. The host computer must use an OPTOMUX serial communication driver. The host can execute a custom program or use a standard software package that supports OPTOMUX drivers such as Intouch-Wonderware, Iconics-Genesis, U.S. Data FactoryLink, Metra-Skyhawk Lt, etc.

General Specifications

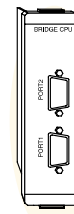

- Two serial ports that support the OPTOMUX protocol

F3-OMUX -1
RS232C/RS422/RS485

F3-OMUX-2
RS422/RS485 (isolated)

- Max of 184 I/O points per CPU (with expansion base unit)
- Scan time is dependent on the communication speed, number of commands sent, type of commands sent, the size of the response and the speed of the host computer.

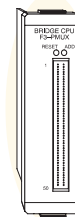

F3-PMUX-1
\$414.00

The F3-PMUX is similar in operation to the F3-OMUX (-1, -2). It uses a parallel interface instead of serial interface.

As a result, it requires the host computer to use a PAMUX communication board (OPTO 22 part number AC28 or equivalent). With this board, you can use PAMUX communication drivers in your host software. Scan time constraints are similar to the OMUX units.

The -1 version has a 26Mhz processor and replaces the F3-PMUX CPU.

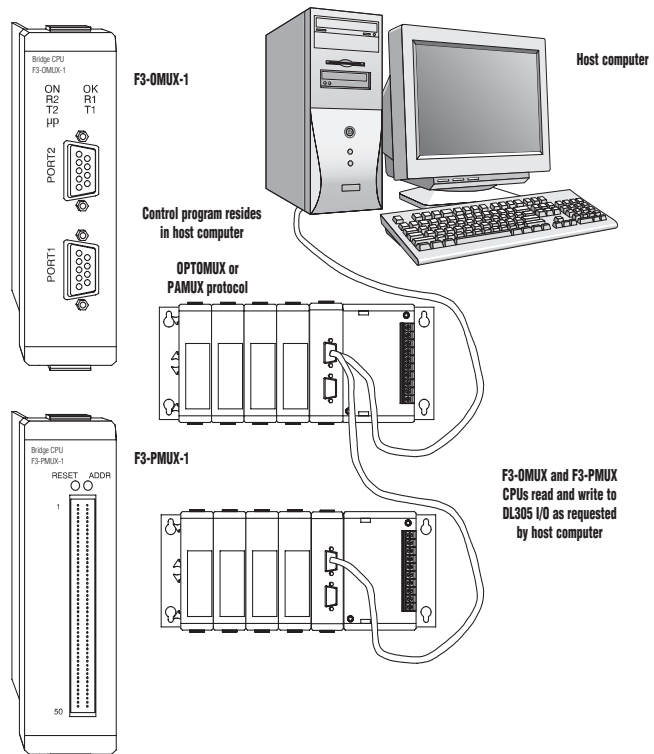

Communications

Determine your communications requirements

The choice of CPU can have a big impact on your communications capabilities in the DL305 family. If you are considering doing any communications, you should use the D3-340 or the D3-350 CPUs. You can communicate with the D3-330 CPU, but you have to add a DL305 Data Communications Unit to connect any device other than a handheld programmer. The Data Communications Unit has only one port.

D3-340 RS232C Communication Port Specifications	
Protocol	DirectNET
Connector	RJ11(handset connector)
Network address	01 to 90
Baud rate	38400, 19200, 9600, 4800, 2400, 1200, 600, 300
Parity-	None or odd
Transfer mode	HEX/ASCII Half-duplex Asynchronous
Data bits	8
Start bits	1
Stop bits	1
Turn around delay	0 to 1980 in 20ms intervals (preset with R777)

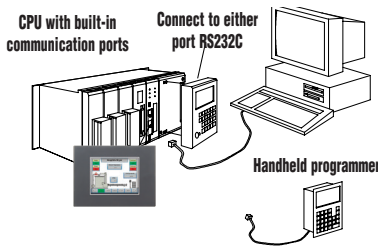

Standard communications

The D3-340 and D3-350 CPUs offer two built-in RS232C communication ports. Operator interfaces and *DirectSOFT* can be connected to either port. On the D3-340 CPU, the handheld programmer is attached directly or with a cable to the parallel port adjacent to the two serial communication ports. On the D3-350 CPU, the handheld programmer is attached to Port 1. The handheld programmer can be operated simultaneously with the communication ports. The D3-340 baud rate and network addresses are set by hardware dipswitches and rotary switches for Port 1. Port 2 uses internal registers that can be changed with a handheld programmer or *DirectSOFT*. Port 1 on the D3-350 is fixed. Port 2 can be configured using the handheld programmer or *DirectSOFT*.

DL305 as a slave on a network

Both ports on the D3-340 and the D3-350 CPUs can serve as slave ports for *DirectNET*. The bottom ports offer additional flexibility in that they can serve as a slave on a Modbus RTU network. The D3-350 even supports RS422, so no RS232-to-RS422 converter is needed. No programming is required in these CPUs for them to act as slave ports.

DL305 as a network master

The bottom built-in communication port of the D3-340 and D3-350 CPUs can serve as a Network Master for *DirectNET*. Up to 90 slave stations can be addressed. The D3-350 can also serve as a MODBUS RTU Master; up to 247 slave stations can be addressed. DL405, DL305 and DL205 controllers can be used as slave stations. (Please note there are certain restrictions pertaining to valid DL205 and DL405 memory types that the D3-340 master can read and write.)

Custom drivers

The DL305 product family supports the *DirectNET* protocol. However, in some applications you may have a need to connect to a device that does not support this protocol. If so, the ASCII/BASIC modules also allow you to write your own custom communication drivers (in BASIC) to connect to special devices. These high-speed modules offer communication rates up to 115.2K baud on RS232C, RS422, and RS485. With 128K of memory, there is ample program or data storage space. (These modules are not supported by the D3-350.)

Network Addresses		
Port	Protocol	Range
1	Slave	1-90
2	Slave	1-90
	Master	0
	MODBUS/RTU	1-247

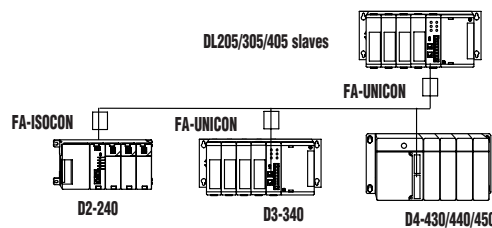

I/O Selection

Choose your I/O modules

There are three major factors to consider when choosing an I/O module:

Environmental specifications:

What environmental conditions will be present?

Hardware specifications:

Does this product have the right features, performance and capacity to adequately serve the application?

Field termination:

How does this module connect to field devices? For DC modules, is a sinking or sourcing module required?

Environmental specifications

The adjacent table lists the environmental specifications that globally apply to the DL305 system (CPU, Bases, and I/O modules). Be sure the modules you choose are operated within these environmental specifications.

Review I/O hardware specifications

The hardware specifications for every DL305 module are listed with each module. Discrete module specifications are shown in a format similar to the example to the right. Take time to understand the specification chart, the derating curve and the wiring diagram.

Specialty module specifications are shown in a format that is relevant for each particular module. These module specifications should help you determine if this module is right for your application.

General I/O module specifications

Specification	Rating
Storage temperature.....	-4°F – 158°F (-20°C to 70°C)
Ambient operating temperature.....	32°F – 140°F (0° to 60°C)
Ambient humidity.....	5% - 95% relative humidity (non-condensing)
Vibration resistance.....	MIL STD 810C, Method 514.2
.....	Shifting: 0.075mm 10–57Hz 3 Axes
.....	Acceleration: 9.8 m/s ² 57–150Hz 3 Axes
.....	Sweeping: 810C, Method 516.2
Peak accel.....	147 m/s ² 11ms, 3 Axes
Noise immunity.....	NEMA (ICS3-304)
Atmosphere.....	No corrosive gases

Discrete module specifications sheet example

D3-08TA-1 AC Output	
Outputs per module	8
Commons per module	2 (isolated)
Operating voltage	80-265VAC
Output type	TRIAC
Peak voltage	265VAC
AC frequency	47-63Hz
ON voltage drop	1.5 VAC @ 1A
Max current	1A/point 3A/common
Max leakage current	1.2mA @ 220VAC 0.52mA @ 110VAC
Max inrush current	10A for 16ms 5A for 100ms
Minimum load	25mA
Base power required	9V 20mA/ON pt. (160 MA Max) 24V N/A
OFF to ON response	1ms Max
ON to OFF response	8.33ms Max
Terminal type	Removable
Status indicators	Logic Side
Weight	7.4oz. (210g)
Fuses	2 (one 5A per common) Non-replaceable

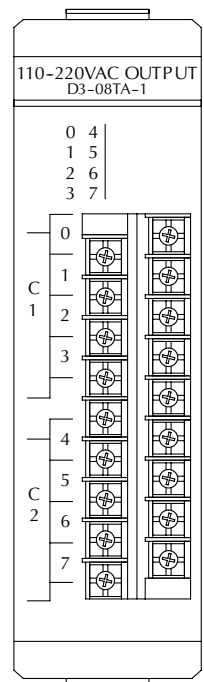
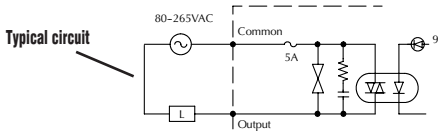
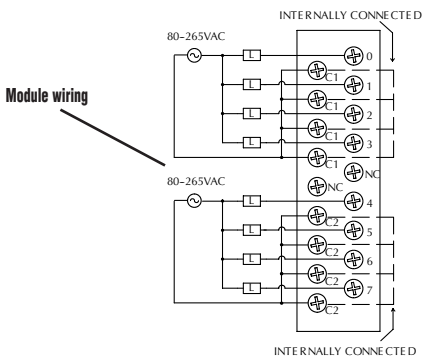
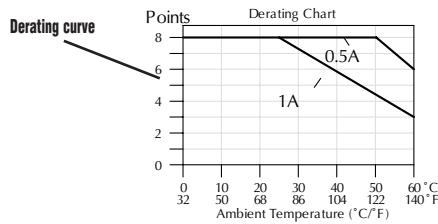

I/O Selection

Factors affecting field termination

Sinking and sourcing for DC field devices: If you are using a DC type of field device, then you should consider whether the device is a sinking or sourcing configuration. This may affect your module selection since it determines the manner in which the device must be wired to the module. (Both sinking and sourcing modules are available.) Refer to the sinking/sourcing section of the Appendix for a complete explanation of how this could affect your system.

Physical wire terminations: In general, DL305 modules use five types of field terminations. They include: removable terminal blocks (included on most 8 and 16-point modules), fixed terminal blocks; specialty D-sub connectors (used on a few 16-point modules), standard D-sub connectors (used on most specialty intelligent modules), and phone jack style (used on the D3-340 CPU, some specialty modules and the universal cable kit). The module descriptions indicate the connector type that is on the module. The following illustrations shows these types of connectors.

Choose your modules

Now that you understand the factors that affect your choice of an I/O module, it's time to choose ones that best suit your needs. When you have selected the modules, proceed to the next section to choose an I/O configuration scheme that best suits your application.

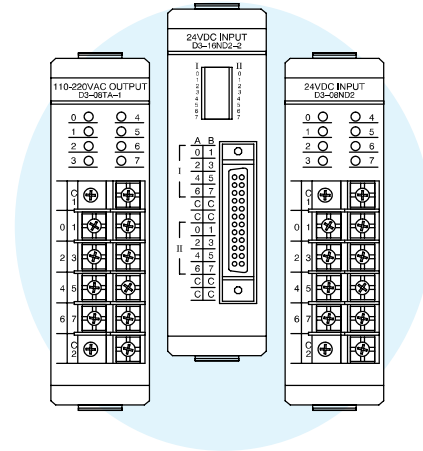

ZIPLink Connection System

If your application requires a lot of relay outputs, consider using the ZIPLink AC or DC relay output modules. These modules can switch high current (10A) loads without putting a load on your base power budget. Refer to the Terminal Blocks and Wiring Solutions section in this catalog for more information.

This logo is placed next to the I/O modules that are supported by the ZIPLink connection systems. See the I/O module specifications at the end of this section.

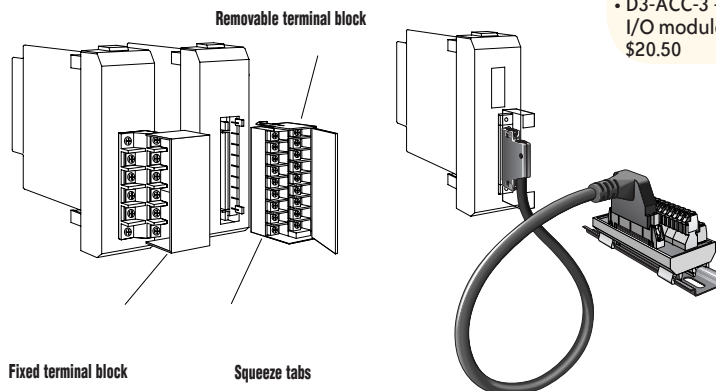

ZIPLinks eliminate the tedious process of wiring PLC I/O terminal blocks.

Extra connectors or spare fuses

There are several types of spare parts that may be useful. A filler module provides a quick and easy way to cover empty slots. Or, it is sometimes helpful to have extra I/O module connectors or spare fuses. Also, keep in mind the DINector family which provides DIN rail-mounted terminal blocks for simplifying and organizing your wiring needs.

- F3-FILL-CB – Filler module for empty slots \$29.00
- D3-16IOCON – 16pt. I/O terminal blocks \$91.00
- D3-8IOCVR – 8pt. I/O terminal plastic covers \$14.00
- D3-16IOCVR – 16pt. I/O terminal plastic covers \$20.50
- D3-IODSHEL – 24-pin D-shell connectors \$32.50
- D3-FUSE-1- Fuses for D3-05B, D3-08B, and D3-10B \$22.00
- D3-FUSE-2 – Fuses for D3-04TAS \$3.25
- D3-FUSE-3 – Fuses for D3-05BDC and D3-10BDC \$27.50
- D3-FUSE-4 – Fuses for D3-08TAS, D3-08TAS-1, F3-16TA-1 and F3-16TA – 2 \$14.00
- D3-FUSE-5 – Fuses for D3-08TR \$45.00
- D3-FUSE-6 – Fuses for F3-08TRS-2 \$14.00
- D3-ACC-1 – Base power terminal strip screws \$20.50
- D3-ACC-2 – Spare terminal screws for 8pt. I/O modules \$20.50
- D3-ACC-3 – Spare terminal screws for 16pt. I/O modules \$20.50

DL305 I/O Configuration

Local I/O – Local I/O are the modules that reside in the same base as the CPU. The status of each I/O point is updated on each I/O scan of the CPU.

Local expansion I/O – Most local CPU bases can be expanded to include expansion I/O. Local expansion is commonly used when there are not enough I/O points available in the existing base configuration or the power budget maximum for the existing base will be exceeded with the addition of I/O. This configuration requires an additional base(s) and an I/O expansion cable(s). The CPU treats the expanded I/O in the same manner as local I/O, with updates every CPU I/O scan. There are certain addressing restrictions that are related to expansion I/O.

Remote I/O – (D3-350 CPU only) – Remote I/O is used when you need to place I/O bases at some remote distance from the CPU base. There are certain restrictions that are related to remote I/O. Check the catalog section on DL205 Remote I/O for examples and additional information.

I/O Configuration Limitations	D3-330	D3-340/ D3-350	D3-350 with -1 bases (AC powered only)
5-slot Local CPU Base System	64 I/O max	64 I/O max	64 I/O max
5-slot Local CPU Base System with a 5-slot Expansion Base	120 I/O max	128 I/O max	144 I/O max
5-slot Local CPU Base System with two 5-slot Expansion Bases	120 I/O max	128 I/O max	224 I/O max
8-slot Local CPU Base System	112 I/O max	112 I/O max	112 I/O max
8-slot Local CPU Base System with a 5-slot Expansion Base	152 I/O max	152 I/O max	192 I/O max
8-slot Local CPU Base System with an 8-slot Expansion Base	N/A	N/A	240 I/O max
8-slot Local CPU Base System with an 8-slot Expansion Base & 5-slot Expansion Base	N/A	N/A	320 I/O max
8-slot Local CPU Base System with two 8-slot Expansion Bases	N/A	N/A	368 I/O max
10-slot Local CPU Base System	128 I/O max	136 I/O max	144 I/O max
10-slot Local CPU Base System with a 5-slot Expansion Base	168 I/O max	176 I/O max	224 I/O max
10-slot Local CPU Base System with a 10-slot Expansion Base	176 I/O max	184 I/O max	304 I/O max

Note: The 16-point modules must be in the first eight slots adjacent to the CPU, rolling over into an expansion base if necessary.

Example of I/O system with expansion I/O

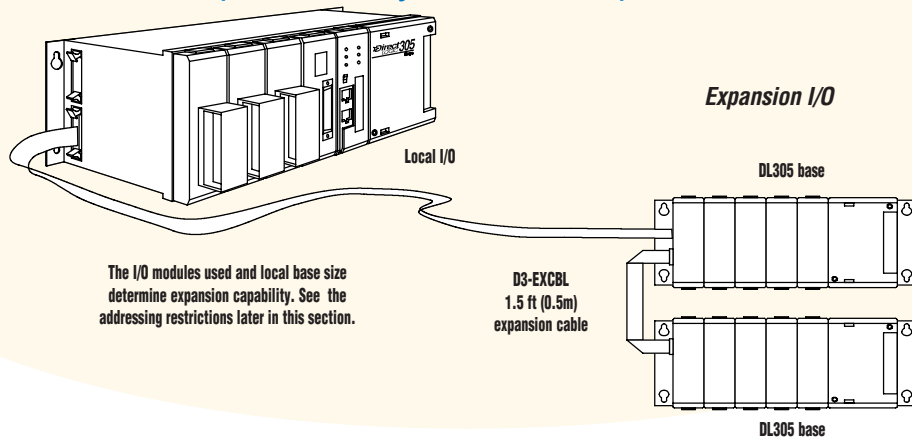

I/O Module Locations

The design of the DL305 has a successful 29-year history. Each time the product family has grown or been enhanced, compatibility with the earlier products has been preserved to protect customer investments. This has resulted in an I/O numbering system and I/O location scheme that has some special requirements.

The Module Placement Guideline table explains the rules that pertain to module location. Some specialty modules have additional requirements. These are explained in their respective module data sheets. Remember that the power budget will limit the location where some modules can be placed in a base.

Module Placement Guidelines	
Device	Placement
CPU	<ul style="list-style-type: none"> The CPU must reside in the first slot of the local CPU base (closest to the power supply). The CPU slot does consume an I/O slot. For example, a D3-05B-1 5-slot base has a slot for the CPU and 4 slots for I/O modules.
16 Point I/O Modules	A maximum of eight 16-point modules may be installed in a system. However, the actual number allowed depends on the type of CPU you are using. D3-330- maximum of seven 16-pt. modules D3-340/350 - maximum of eight 16-pt. modules D3-350 - w/-1 base can have 16-pt. modules in all available slots
Note: some specialty modules, such as the High Speed Counter and Thumbwheel Interface Unit, require 16 points and are treated as 16-point modules. The 16-point modules must be in the first 8 slots adjacent to the CPU. They may roll over into an expansion base if necessary. If any of the 8 slots adjacent to the CPU are not used for 16-point modules, they can be used for 8-point modules.	
Analog	Analog modules must reside in any valid 16-point I/O module slot.
ASCII BASIC Modules	ASCII BASIC modules can be placed in any valid 16-point I/O slot. (D3-350 does not support these modules)
High Speed Counter	A High-Speed Counter must be used in the first four I/O module slots in the local CPU base. (D3-350 does not support these modules)

I/O Points Usage Table for Modules					
The following table indicates the number of I/O points that are used by each module. Use this information to ensure your I/O configuration stays within the valid I/O count of your chosen CPU.					
DC Input		DC Output		Relay Output	
D3-08ND2	8	D3-04TD1	4	D3-08TR	8
D3-16ND2-1	16	D3-08TD1	8	F3-08TRS-1	8
F3-16ND3F	16	D3-08TD2	8	F3-08TRS-2	8
		D3-16TD1-1	16	D3-16TR	16
AC Input		D3-16TD2	16	Specialty Modules	
D3-08NA-1	8	AC Output		D3-08SIM	8
D3-08NA-2	8	D3-04TAS	4	D3-DCM	0*
D3-16NA	16	F3-08TAS-1	8	Analog	
AC/DC Input		D3-08TA-1	8	F3-04ADS	16
D3-08NE3	8	D3-08TA-2	8	F3-08AD-1	16
D3-16NE3	16	F3-16TA-1	16	F3-08THM-n	16
		F3-16TA-2	16	F3-16AD	16
				F3-04DA-1	16
				F3-04DAS	16

*Use only with D3-350 CPU, "-1" base, not in slot 8.

DL305 Addressing

D3-330/340

Like the DL205 and DL405 products, the DL305 uses octal addressing. That is, the I/O point addressing does not include any "8s" or "9s". The DL305 is primarily different in that it uses slot addressing. The addresses are assigned to the I/O slots and do not depend on the type of module installed (input vs. output). Also, the addresses are not sequential on 16-point modules. For example, a 16-point module in slot 0 (the first I/O slot) would have I/O addresses 000-007 for the first eight points and 100-107 for the next eight points.

There are also certain restrictions to consider when designing your system. Most of these situations arise when 16-point modules are used, or when expansion bases must be added to the system.

The diagrams on this and the following page illustrate the I/O base/addressing combinations that are possible when designing a system.

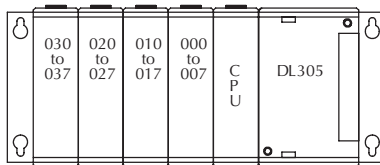

Slots: 3 2 1 0 CPU

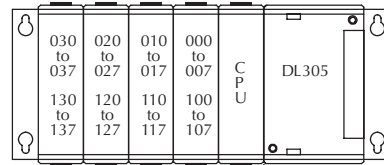

Slots: 3 2 1 0 CPU

5-slot base example configurations

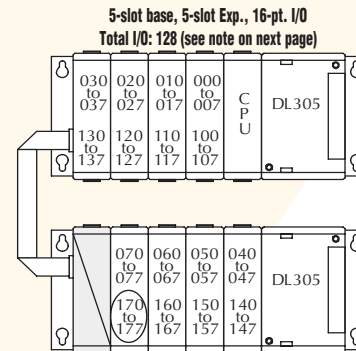
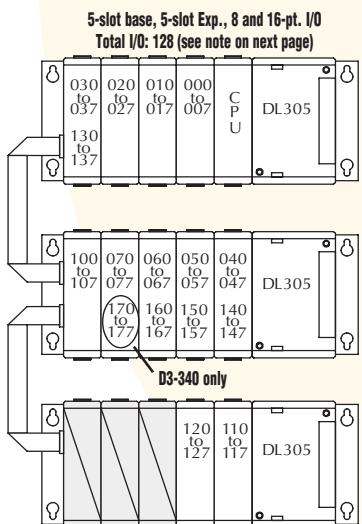
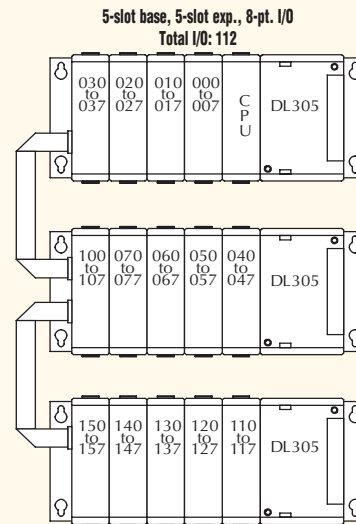
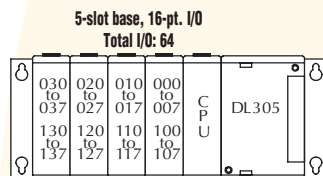
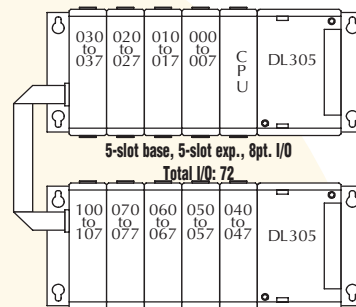
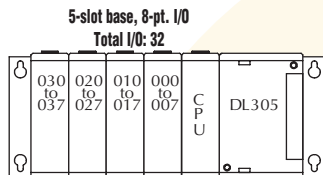

D3-340 only

DL305 Addressing

8-slot base example configurations (D3-330/340)

8-slot base, 8-pt. I/O
Total I/O: 56

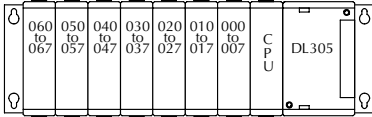

8-slot base, 5-slot expansion, 8-pt. I/O
Total I/O: 96

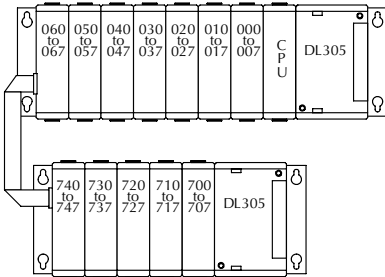

8-slot base, 16-pt. I/O
Total I/O: 112

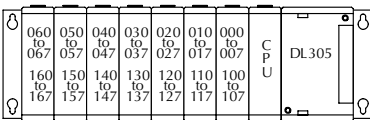

8-slot base, 5-slot expansion, 16-pt. I/O
Total I/O: 156

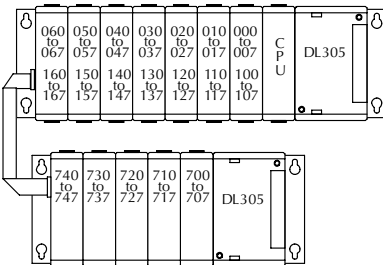

***NOTE:** Regardless of base size, if a 16-pt. module is used in Slot 6 for the D3-330 CPU, 160 through 167 will not be available for control-ready assignments. If a 16-pt. module is used in Slot 6 and/or Slot 7 for a D3-340 CPU, 160-167 and/or 170-177 are not available for control relay assignments.

10-slot base example configurations

10-slot base, 8-pt. I/O
Total I/O: 72

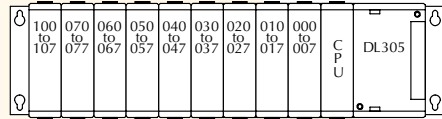

10-slot base, 8-pt. and 16-pt. I/O
Total I/O: 128 (see note)

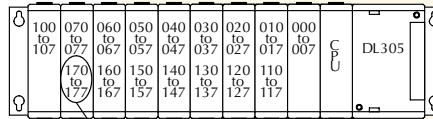

D3-340/D3-350 only

10-slot base, 8-pt. and 16-pt. I/O
Total I/O: 136 (see note)

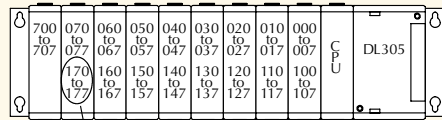

D3-340/D3-350 only

10-slot base, 5-slot expansion, 8-pt. and 16-pt. I/O
Total I/O: 176 (see note)

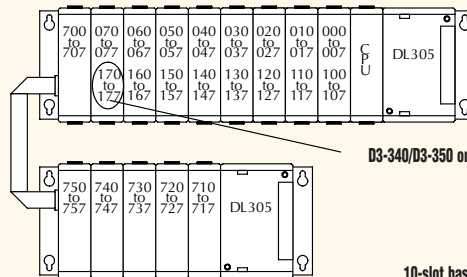

D3-340/D3-350 only

10-slot base, 10-slot expansion, 8-pt. I/O
Total I/O: 152

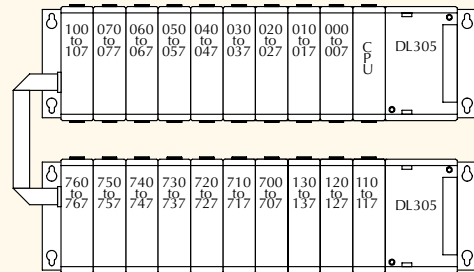

10-slot base, 10-slot expansion, 8-pt. and 16-pt. I/O
Total I/O: 184 (see note)

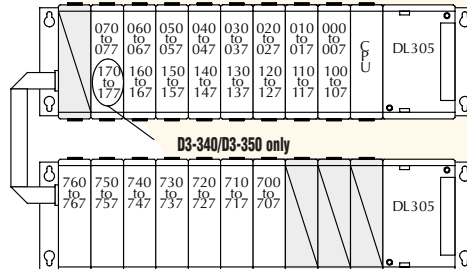

D3-340/D3-350 only

D3-350 Addressing

Using “-1” bases

The D3-350 CPU can be installed in legacy DL305 bases or the “-1” bases. When installed in one of the legacy bases, or if the bases are mixed, the addressing scheme and module placement restrictions follow that of the D3-340 CPU. Refer to the previous pages for more detailed information. Note: These I/O addressing configurations are for the latest style bases (-1 on the end of the part number). If you are using an older series base, refer to the User’s Manual appendix for correct addressing.

I/O addressing

When the D3-350 CPU is installed in a “-1” base and all expansion bases are also “-1” bases, the addressing scheme is very simple. 16 I/O points are assigned to each slot. This applies even if the slot contains an 8-point module or if the slot is empty. Expansion base addresses follow in succession from the previous base. Input modules are assigned addresses X0 through X777. Output modules are assigned address Y0 through Y777.

D3-05B-1 base using 8-pt. I/O modules

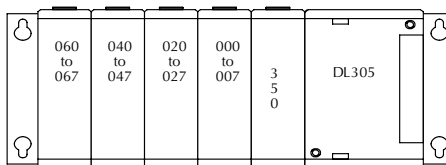

D3-05B-1 base using 16-pt. I/O modules

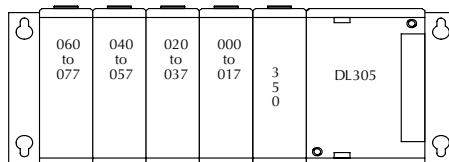

5-slot base example configurations -1 bases

5-slot local
Total I/O: 64

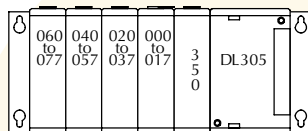

5-slot local and two 5-Slot expansions
Total I/O: 224

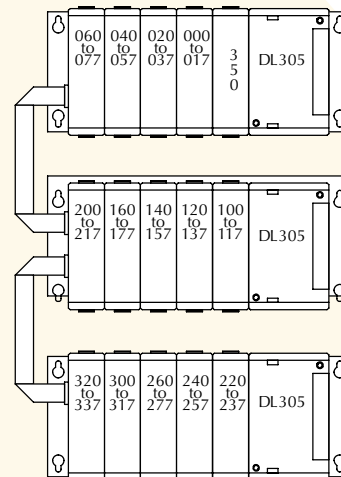

5-slot local and 5-slot expansions
Total I/O: 144

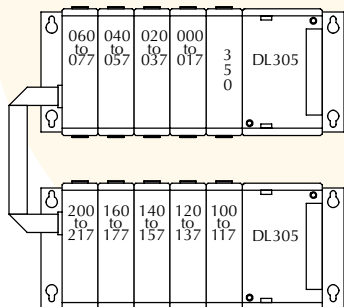

D3-350 Addressing

8-slot base example configurations

-1 bases

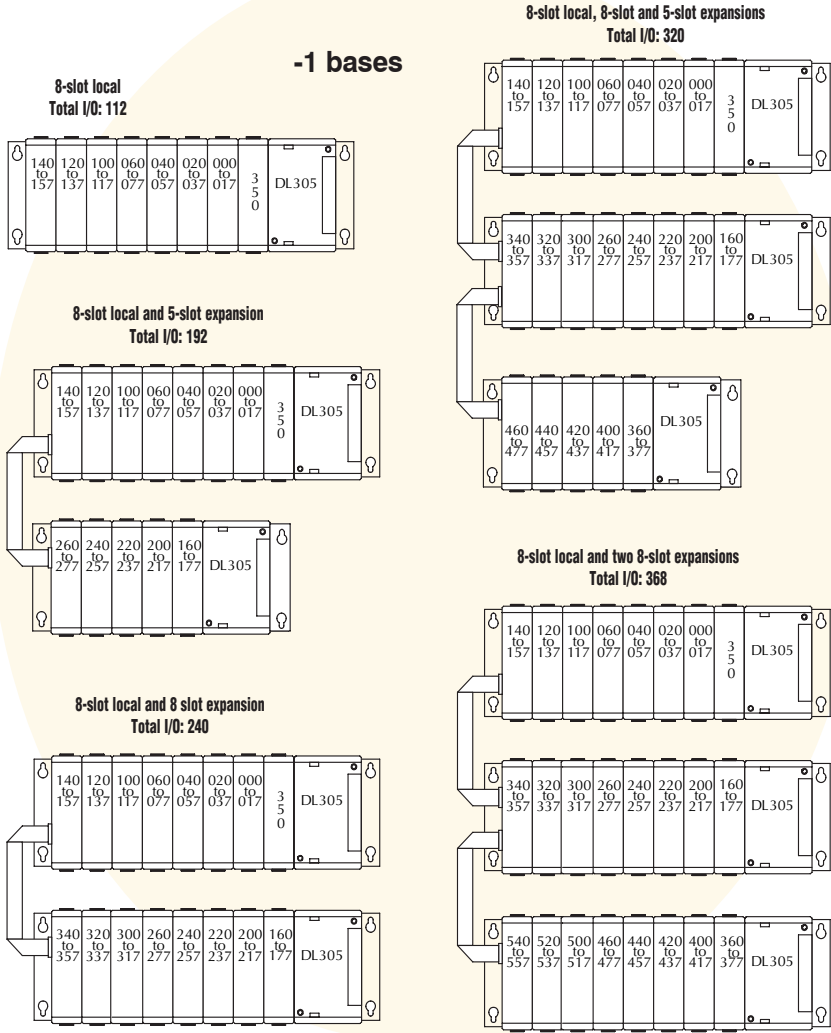

10-slot base example configurations

-1 bases

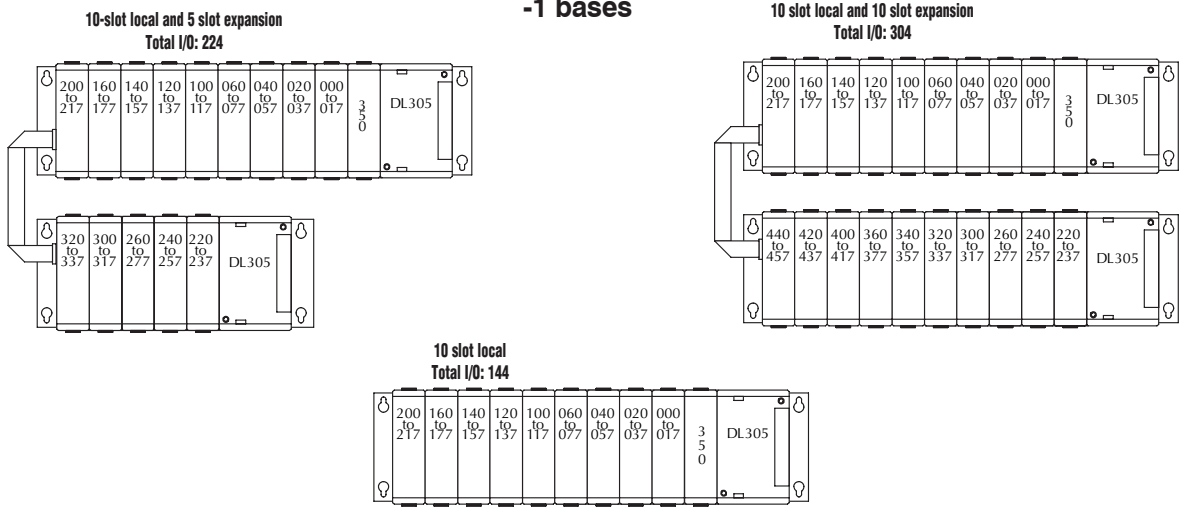

Company Information

Control Systems Overview

CLIC PLC

Do-More PLCs Overview

Do-More H2 PLC

Do-More T1H PLC

DirectLOGIC PLCs Overview

DirectLOGIC DL05/06

DirectLOGIC DL105

DirectLOGIC DL205

DirectLOGIC DL305

DirectLOGIC DL405

Productivity Controller Overview

Productivity 3000

Universal Field I/O

Software

C-More HMI

C-More Micro HMI

ViewMarq Industrial Marquee

Other HMI

Communications

Appendix Book 1

Terms and Conditions

DL305 Base Specifications

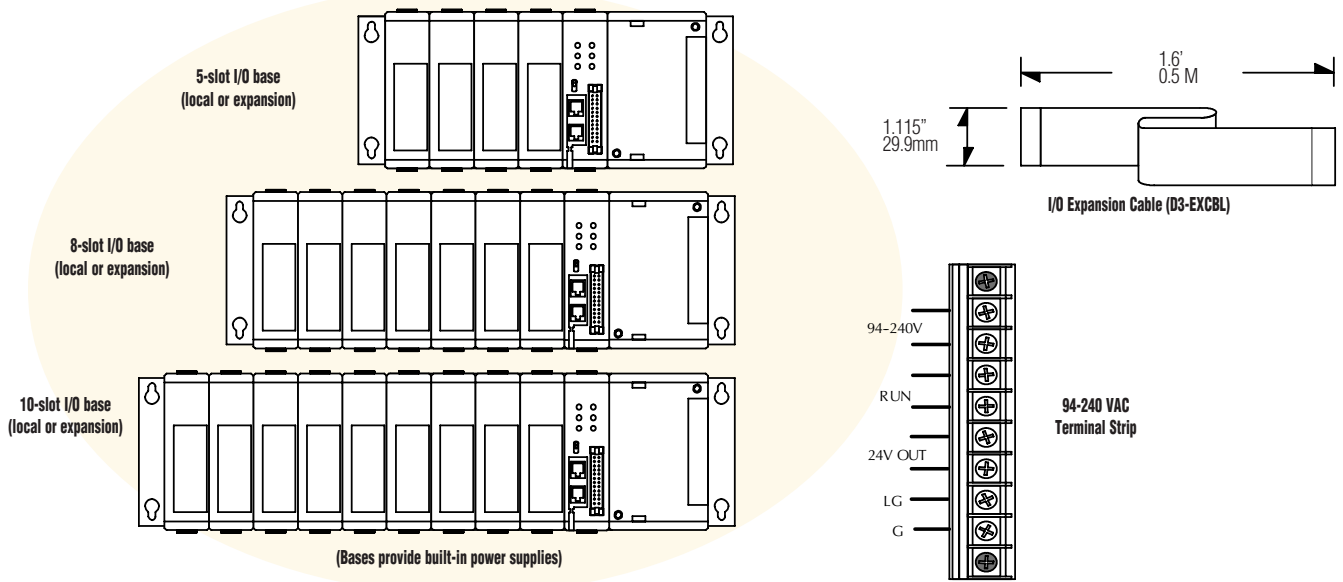

	D3-05B-1 \$309.00	D3-05BDC \$332.00	D3-08B-1 \$375.00	D3-10B-1 \$505.00	D3-10BDC \$422.00
Number of Slots	5	5	8	10	10
Local CPU Base	Yes	Yes	Yes	Yes	Yes
Expansion Base	Yes CPU base and two expansion bases. If CPU base is 5-slot, then the expansion bases must be 5-slot also.	Yes CPU base and two expansion bases. If CPU base is 5-slot, then the expansion bases must be 5-slot also.	Yes (D3-350 only) CPU base and two expansion bases. If CPU base is 8-slot, then the expansion bases must be 8-slot or 5-slot	Yes CPU base and one expansion bases. If CPU base is 10-slot, then the expansion bases must be 10-slot or 5-slot	Yes CPU base and one expansion bases. If CPU base is 10-slot, then the expansion bases must be 10-slot or 5-slot.
Input Voltage Range	85-264VAC 47-63Hz	20.5-30VDC <10% ripple	85-264VAC 47-63Hz	85-264VAC 47-63Hz	20.5-30VDC <10% ripple
Base Power Consumption	85 VA Max	48 Watts	85VA Max	85VA Max	65 Watts
Inrush Current Max.	30A 1ms	30A	30A 1ms	30A 1ms	30A
Dielectric Strength	1500VAC for one minute between terminals of AC P/S, run output, common, 24VDC	1500VAC for one minute between 24VDC input terminals and run output	1500VAC for one minute between terminals of AC P/S, run output, common, 24VDC	2000VAC for one minute between terminals of AC P/S, run output, common, 24VDC	1500VAC for one minute between 24VDC input terminals and run output
Insulation Resistance	>10Mohm at 500VDC	>10Mohm at 500VDC	>10Mohm at 500VDC	>10Mohm at 500VDC	>10Mohm at 500VDC
Power Supply Output (Voltage Ranges and Ripple)	(5VDC) 4.75-5.25V 5% ripple (9VDC) 8.5-10V 5% ripple (24VDC) 20-28V 5% ripple	(5VDC) 4.75-5.25V 5% ripple (9VDC) 8.5-10V 5% ripple (24VDC) 20-28V 5% ripple	(5VDC) 4.75-5.25V 5% ripple (9VDC) 8.5-10V 5% ripple (24VDC) 20-28V 5% ripple	(5VDC) 4.75-5.25V 5% ripple (9VDC) 8.5-10V 5% ripple (24VDC) 20-28V 5% ripple	(5VDC) 4.75-5.25V 5% ripple (9VDC) 8.5-10V 5% ripple (24VDC) 20-28V 5% ripple
5 VDC Current Supplied	.7A	1.4A	1.0A	1.0A	1.4A
9 VDC Current Supplied	2.0A	0.8A	2.0A	2.0A	1.7A
24 VDC Current Supplied	0.5A	0.5A	0.5A	0.5A	0.5A
Auxiliary 24 VDC Output	100mA max	None	100mA max	100mA max	None
Run Relay	250VAC 4A (resistive load)	250VAC 4A (resistive load)	250VAC 4A (resistive load)	250VAC 4A (resistive load)	250VAC, 4A (resistive load)
Fuses	2A (250V) Non-replaceable	4A (250V) User-replaceable D3-FUSE-3 \$27.50	2A (250V) Non-replaceable	2A (250V) Non-replaceable	4A (250V) User-replaceable D3-FUSE-3 \$27.50
Dimensions W/H/D	11.42x4.85x4.41 in. (290x123x112 mm)	11.42x4.85x4.41 in. (290x123x112 mm)	15.55x4.85x4.41 in. (395x123x112 mm)	18.3x4.85x4.41 in. (465x123x112 mm)	18.34x4.85x4.41 in. (465x123x112 mm)
Weight	37oz. (1050g)	34oz. (964g)	44oz. (1250g)	51.1oz. (1450g)	50.5oz. (1432g)

Power Budget

Managing your power resource

The I/O configuration depends on your choice of I/O modules, bases and I/O location. When determining the types and quantity of I/O modules you will be using, it's important to remember there is a limited amount of power available from the power supply.

The chart on the next page indicates the power supplied and used by each DL305 device. The adjacent chart shows an example of how to calculate the power used by your particular system. These two charts should make it easy for you to determine if the devices you have chosen fit within the power budget of your system configuration.

If the I/O you have chosen exceeds the maximum power available from the power supply, you can resolve the problem by shifting some of the modules to an expansion base.

Use ZIPLinks to reduce power requirements

If your application requires a lot of relay outputs, consider using the ZIPLink AC or DC relay output modules. These modules can switch high current (10A) loads without putting a load on your base power budget. Refer to the Wiring Solutions section in this catalog for more information.

This logo is placed next to I/O modules that are supported by the ZIPLink connection systems. See the I/O module specifications at the end of this section.



WARNING: It is extremely important to calculate the power budget correctly. If you exceed the power budget, the system may operate in an unpredictable manner, which may result in a risk of personal injury or equipment damage.

Example: how to calculate your power usage

The following example shows how to calculate the power budget for the DL305 system. The examples are constructed around a single 5-slot base using the devices shown. It is recommended you construct a similar table for each base in your DL305 system.

- Using a chart similar to the one below, fill in column 2.
- Using the tables on the opposite page, enter the current supplied and used by each device (columns 3, 4, and 5). Devices which fall into the "Other" category (Row D) are devices such as the Handheld Programmer or a Data Communication Unit, which also have power requirements, but do not directly plug into the base.

- Add the current used by the system devices (columns 3, 4, and 5), starting with Slot 1, then put the total in the row labeled "Maximum Current Required" (Row E).
- Subtract the row labeled "Maximum Current Required" (Row E), from the row labeled "Current Supplied" (Row B). Place the difference in the row labeled "Remaining Current" (Row F).
- If "Maximum Current Required" is greater than "Current Supplied" in columns 3, 4 or 5, the power budget will be exceeded. It will be unsafe to use this configuration and you will need to restructure your I/O configuration.

A	Column 1	Column 2	Column 3	Column 4	Column 5
	Base # 0	Device Type	5 VDC (mA)	9VDC (mA)	24V(mA)
B	Current Supplied				
	5-slot Base	D3-05BDC	1400	800	500
C	Current Required				
	CPU Slot	D3-330	300	50	0
	Slot 0	D3-16NE3	0	130	0
	Slot 1	D3-16NE3	0	130	0
	Slot 2	D3-08TA-1	0	160	0
	Slot 3	D3-08TA-1	0	160	0
D	Other				
		Handheld prog D3-HPP	50	50	0
E	Maximum Current Required		360	680	0
F	Remaining Current		1040	120	500

Company
InformationControl Systems
Overview

CLICK PLC

Do-More
PLCs OverviewDo-More H2
PLCDo-More T1H
PLCDirectLOGIC
PLCs OverviewDirectLOGIC
DL05/06DirectLOGIC
DL105DirectLOGIC
DL205DirectLOGIC
DL305DirectLOGIC
DL405Productivity
Controller
OverviewProductivity
3000Universal
Field I/O

Software

C-More
HMIC-More Micro
HMIViewMarq
Industrial
Marquees

Other HMI

Communications

Appendix
Book 1Terms and
Conditions

DL305 Power Requirements

This section shows the amount of power supplied by the base power supplies and the amount of power used by each DL305 device. Note the base power supplies provide three internal voltages (5V, 9V, 24V). The chart shows how much power from each of these power sources is required for each DL305 device. Use this information when calculating the power budget for your system.

In addition to the three internal power sources, the DL305 bases provide an external power connection. There is 24 VDC available from the 24 VDC output terminals on the bases (except D3-05BDC and D3-10BDC).

The 24 VDC can be used to power external devices or DL305 modules that require external 24 VDC. The power used from this external 24 VDC output reduces the internal system 24 VDC that is available to the modules by an equal amount. When using the 24 VDC output at the base terminal, it is recommended that 100 mA not be exceeded.

Power Consumed				
Device	5V(mA)	9V(mA)	24V(mA)	Ext req.
CPUs				
D3-330	300	50	0	0
D3-340	300	20	0	0
D3-350	500	0	0	0
DC Input Modules				
D3-08ND2	0	10	112	0
D3-16ND2-1	0	25	224	0
F3-16ND3F	0	148	68	0
AC Input Modules				
D3-08NA-1	0	10	0	0
D3-08NA-2	0	10	0	0
D3-16NA	0	100	0	0
AC/DC Input Modules				
D3-08NE3	0	10	0	0
D3-16NE3	0	130	0	0
DC Output Modules				
D3-04TD1	0	12	5	0
D3-08TD1	0	20	24	0
D3-08TD2	0	30	0	0
D3-16TD1-1	0	40	96	0
D3-16TD2	0	180	0	0
AC Output Modules				
D3-04TAS	0	12	0	0
F3-08TAS-1	0	200	0	0
D3-08TA-1	0	160	0	0
D3-08TA-2	0	160	0	0
F3-16TA-2	0	250	0	0
D3-16TA-2	0	400	0	0

Power Supplied				
Device	5V(mA)	9V(mA)	24V(mA)	24 V (mA)
D3-05B-1	900	2000	500	100
D3-08B-1	900	2000	500	100
D3-10B-1	900	2000	500	100
D3-05BDC	900	2000	500	None
D3-10BDC	900	2000	500	None
D3-05B-NR	900	2000	500	100
D3-08B-NR	900	2000	500	100
D3-05BDC-NR	900	2000	500	None
Power Consumed				
Device	5V(mA)	9V(mA)	24V(mA)	External required
Relay Output Modules				
D3-08TR	0	360	0	0
F3-08TRS-1	0	296	0	0
F3-08TRS-2	0	296	0	0
D3-16TR	0	480	0	0
Analog Temperature and Thermocouple Modules				
F3-04ADS	0	183	50	0
F3-08AD-1	0	45	55	0
F3-08THM-n	0	50	34	0
F3-16AD	0	55	65	0
F3-04DA-1	0	144	108	0
F3-04DAS	0	154	145	0
Communications and Networking				
D3-232 DCU	500	0	0	Optional 5V@500mA
D3-422 DCU	500	0	0	Optional 5V@500mA
FA-UNICON	0	0	0	24V or 5V@ 100mA
D3- DCM	0	300	0	0
Specialty Modules				
D3-08SIM	0	10	112	0
D3-HSC	0	70	0	0
D3-TCSU	40	5	0	0
Programming				
D3-HP	50	50	0	0
D3-HPP	50	50	0	0
D2-HP	200	0	0	0
Specialty CPUs				
F3-OMUX-1	409	0	0	0
F3-OMUX-2	262	0	150	0
F3-PMUX	455	0	0	0
F3-RTU	416	0	0	0
Operator Interface				
DV-1000	150	0	0	0
C-more Micro-Graphic	210	0	0	0

Dimensions and Installation

It is important to understand the installation requirements for your DL305 system. This will help ensure that the DL305 products operate within their environmental and electrical limits.

Plan for safety

This catalog should never be used as a replacement for the user manual. The user manuals, D3-USER-M and D3-350-M (available for download from our web site), contain important safety information that must be followed. The system installation should comply with all appropriate electrical codes and standards.

Base dimensions and mounting orientation

Use the diagrams to the right to make sure the DL305 system can be installed in your application. DL305 bases must be mounted horizontally to ensure proper airflow for cooling purposes. It is important to check these dimensions against the conditions required for your application. For example, it is recommended that you leave 1.5" depth for ease of access and cable clearance. However, your distance may be greater or less. Also, check the installation guidelines for the recommended cabinet clearances.

Specification	Rating
Storage Temperature	-4°F - 158°F (-20°C to 70°C)
Ambient Operating Temperature	32°F - 131°F (0° to 55°C)
Ambient Humidity	30% - 95% relative humidity (non-condensing)
Vibration Resistance	MIL STD 810C, Method 514.2
Shock Resistance	MIL STD810, Method 516.2
Noise Immunity	NEMA (ICS3-304)

DL305 mounting depths

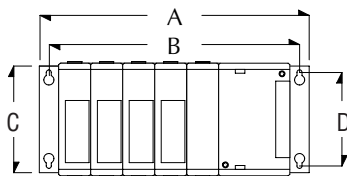
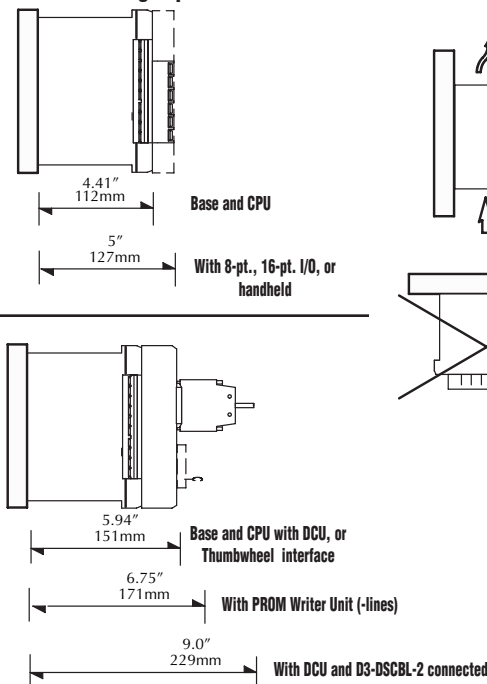

Base	Price	A	B	C	D
D3-05B-1	\$309.00	11.41"	290mm	10.63"	270mm
D3-08B-1	\$375.00	15.55"	395mm	14.76"	375mm
D3-10B-1	\$505.00	18.30"	465mm	17.51"	445mm

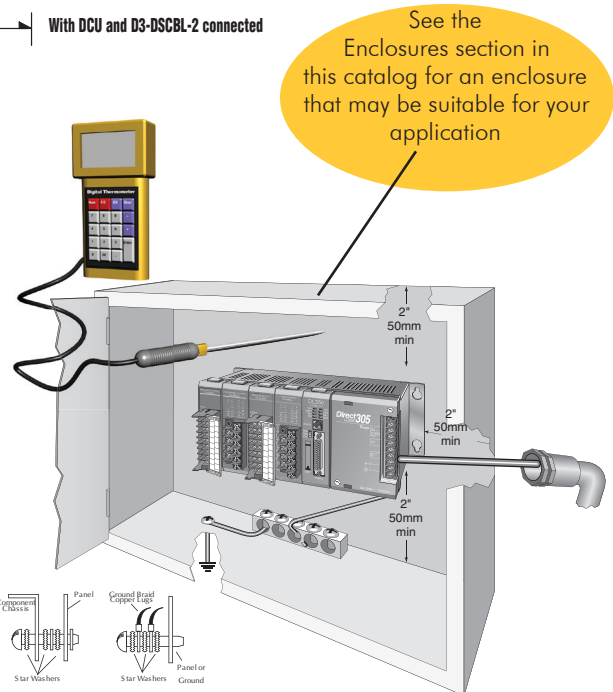

Data Communications Module

D3-DCM

\$219.75

The DL305 Data Communications Module (DCM) is a general purpose communications interface for the DL305 family of PLCs. This module only works with the D3-350 CPUs. It will not work with the D3-330 or D3-340 CPUs or in DC-powered bases. You must use the "-1" type base. The DCM module is primarily used for three purposes:

- Extra general purpose communications port to connect a personal computer, operator interface, etc.
- Network interface to a DirectNET network
- Network interface to a MODBUS RTU protocol

The D3-350 CPU offers a built-in communication port. However, if more communication ports are needed, they can easily be added by installing Data Communication Modules. Any device that can be connected to the communication port of a D3-350 CPU can be connected to the DCM. However, make sure the device has a DL305-compatible driver. This allows additional connections of devices, such as operator interfaces, personal computers, etc. Since the DCM does not require any programming, you can set the DCM communication parameters, connect the cables, and start transferring data.

Specifications	
Module Type	Intelligent
Modules per CPU	3 maximum, slot 0 to 7, cannot use slot 8
CPUs Supporting the DCM	D3-350 (firmware V1.08C or later)
Communications	<ul style="list-style-type: none"> • RS232C/422 signal levels <i>DirectNET™</i> • K-sequence or MODBUS RTU slave protocol • Baud rate selectable from 300 to 38.4K baud • Odd or NO parity, HEX or ASCII mode
Recommended Cable	Belden 9729 or equivalent
Field Wiring Connector	25-pin D-shell connector
Internal Power Consumption	300mA maximum at 9VDC, (supplied by base power supply)
Operating Environment	0°C to 60°C (32°F to 140°F), 5% to 95% humidity (non-condensing)
Manufacturer	Koyo Electronics

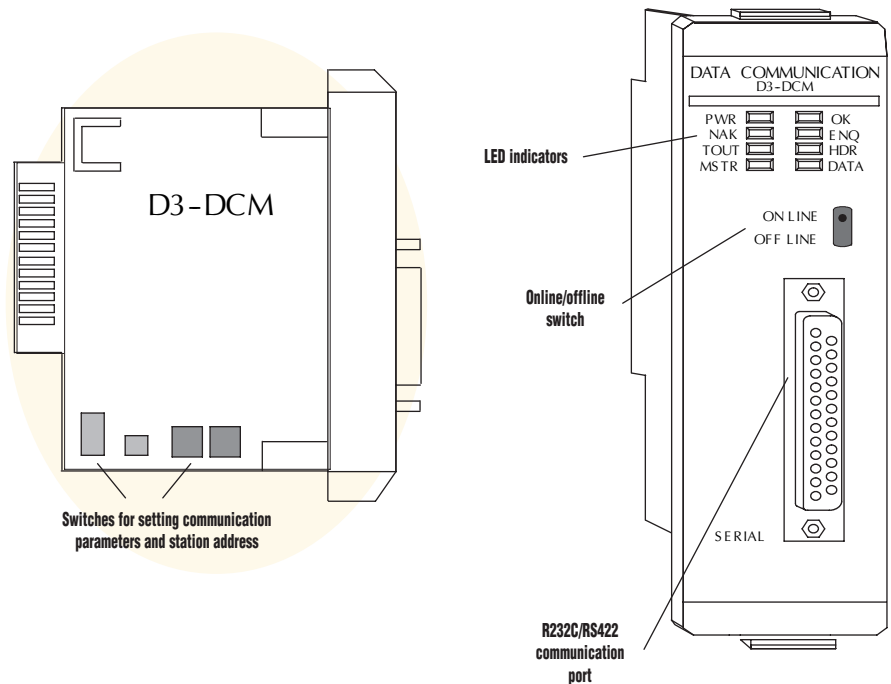

Connect the DCM to our MDM-TEL serial modem (see the Communication Products section of this catalog for details on the modem)

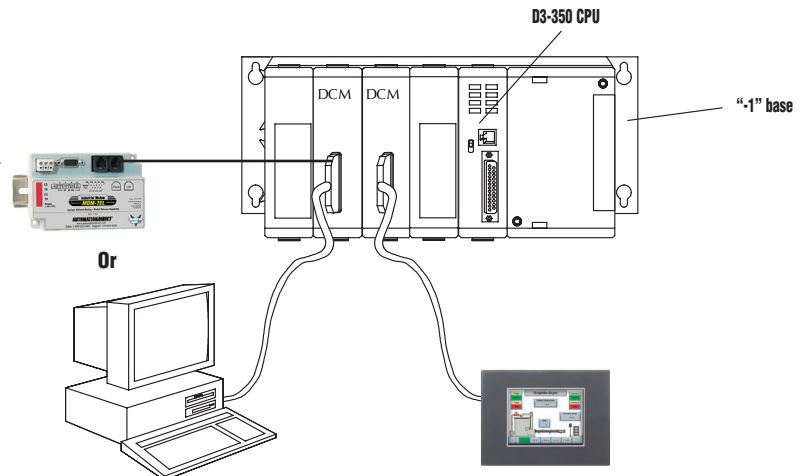

Data Communications Module

DirectNET network interface

The DCM can be used as a network interface for applications requiring data to be shared between PLCs, or between PLCs and an intelligent device such as a host computer. The DCM connects easily to *DirectNET*. This network allows you to upload or download virtually any type of system data including Timer/Counter data, I/O information, and V-memory information from most *DirectLOGIC* or compatible PLCs. The DCM allows the D3-350 CPU to function as a network master or as a network slave.

Low-cost MODBUS interface

The DCM can be used as a slave station interface to connect your D3-350 system to the MODBUS network using the MODBUS RTU protocol. The host system must be capable of issuing the MODBUS commands to read or write the appropriate data. Since the D3-350 CPU can act as a MODBUS master, it is now very easy to implement an entire D3-350 control scheme using the MODBUS RTU protocol.

Network master

The DCM allows the D3-350 to serve as a master of a *DirectNET* Network. The DCM takes communication requests issued from the CPU's RLL program (the network part of the program can be very simple, as few as 7 words) and automatically converts these requests into network commands to read data from or write data to a network slave station. This capability also allows a simple peer-to-peer configuration of two D3-350 systems, each with a DCM. In this scenario, either station can initiate the request for data.

Note: The F1-130 CPUs and the D2-230 do not support DirectNet.

Network slave

The D3-350 CPU has built-in ports that support the *DirectNET* protocol. If these ports are occupied, a DCM can be added to provide an additional network slave port. In this case, the DCM "listens" to the network for any messages containing the DCM's address. The DCM deciphers the network commands, carries out the request to read or write data and sends confirmation and/or information to the master station. Since the DCM does not require any programming, you can set the DCM communication parameters, connect the cables and start transferring data.

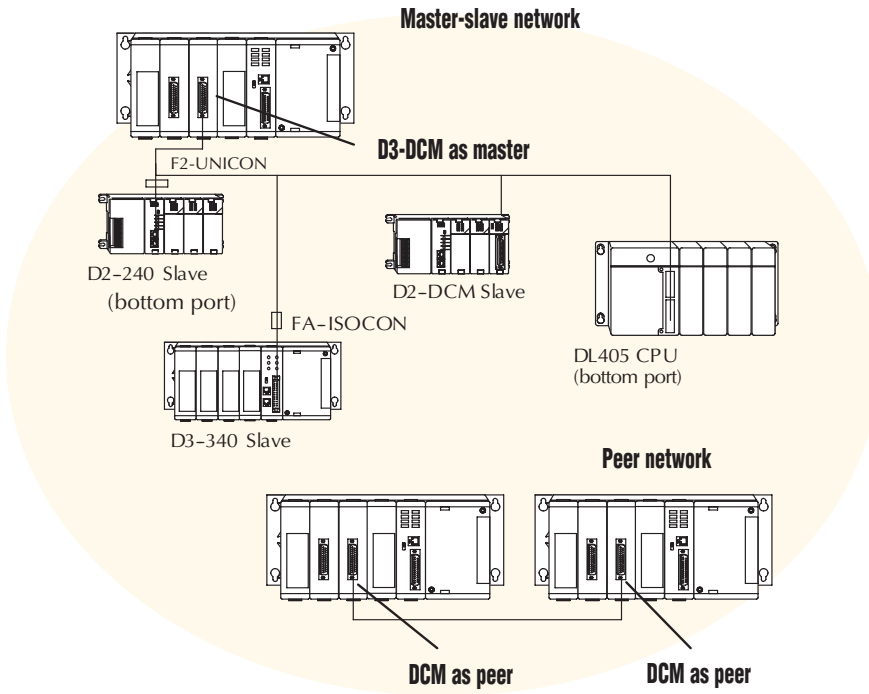

MODBUS network interface

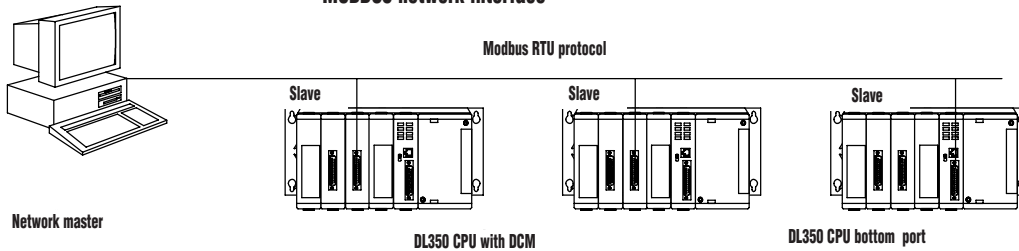

Company Information

Control Systems Overview

CLICK PLC

Do-More PLCs Overview

Do-More H2 PLC

Do-More T1H PLC

DirectLOGIC PLCs Overview

DirectLOGIC DL05/06

DirectLOGIC DL105

DirectLOGIC DL205

DirectLOGIC DL305

DirectLOGIC DL405

Productivity Controller Overview

Productivity 3000

Universal Field I/O

Software

C-More HMI

C-More Micro HMI

ViewMarq Industrial Marquees

Other HMI

Communications

Appendix Book 1

Terms and Conditions

Data Communications Units

D3-232-DCU \$666.00
D3-422-DCU Retired

The DL305 Data Communications Unit (DCU) is a general purpose communications interface for the DL305 family. This unit is used with the D3-330 CPU for the following reasons:

- As a general purpose communications port to connect a personal computer, operator interface, etc.
- Network interface to a DirectNET network.
- The DCU is not necessary for the D3-340 or D3-350 CPUs since they have built-in communication ports.

Mode 1: general purpose port

You can use the DCU as a general purpose communication port to connect your DL305 to various devices such as an operator interface or personal computer. The DCU does not require any programming. You can simply set the DCU communication parameters, connect the appropriate RS232C or RS422 communication cables, and start programming or transferring data. Typically this application would use the RS232C version of the DCU (D3-232-DCU).

Specifications	
Unit Type	Intelligent
Units per CPU	One, direct connect to CPU
Communications	RS232C with D3-232-DCU RS422 with D3-422-DCU DirectNET™, Baud rate selectable from 300 to 19.2K baud. Odd or No parity. HEX or ASCII mode.
Field Wiring Connector	25-Pin D-shell connector
Internal Power Consumption	500mA from 5VDC maximum. Supplied by base power supply or external supply.
Operating Environment	0°C to 60°C (32°F to 140°F), 5% to 95% humidity (non-condensing)
Manufacturer	Koyo Electronics

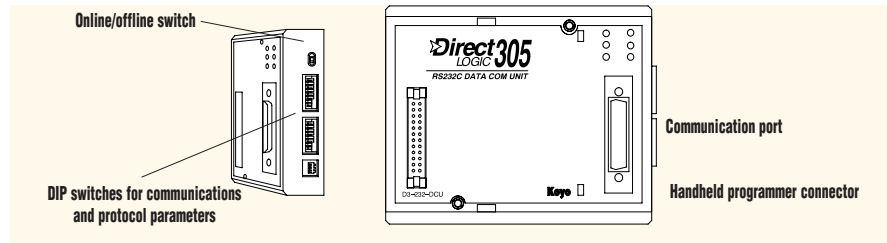

Mode 2: DirectNET network interface

The DCU can be used as a network interface for applications requiring data to be shared between PLCs, or between PLCs and an intelligent device such as a host computer. The DCU supports DirectNET protocol (often called HostLink or CCM). Since most of our product families support this protocol, you can easily build a simple network that allows you to upload or download virtually any type of system data, including Timer/Counter data, I/O information, and V-memory information.

Typically this application would use the RS422 version of the DCU (D3-422-DCU).

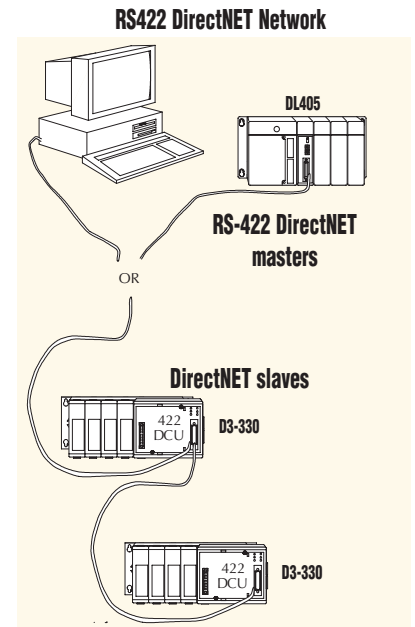

FA-UNICON \$99.00



The FA-UNICON Universal Converter provides an inexpensive way to convert D3-422-DCU RS-422 signals into RS-232C signals for connection to a PC. This kit contains the converter itself and several specialty connectors and cables that make it easy to use and install. The converter requires an external power source for operation.

The FA-UNICON can also be used with GE IC610CCM105 and TI 305-02DM RS-422 DCU units.

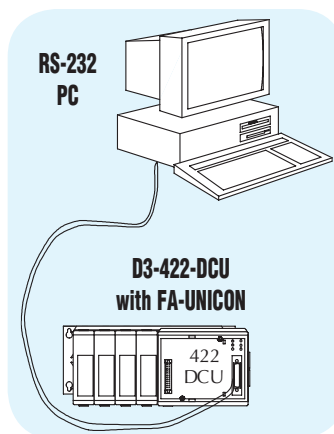

The FA-UNICON contains the following items:

- RS-232/422 converter
- 25-pin male-to-male gender changer
- 25-pin male to RJ12 6P6C connector
- 3' cable, RJ12 6-pin plug to RJ11 4-pin plug
- 7' cable with RJ12 6-pin plug to RJ12 6-pin
- DB9 Female to RJ12 6P6C connector

FA-UNICON Specifications

- Supply voltage: 22-26 VDC or 5 VDC
- No load current: 65 mA
- Max. current: 100 mA
- Operating temp: 45°C (113°F) for 24V supply, 60°C (140°F) for 5V supply

ZIPLINK™ Wiring Solutions

AUTOMATIONDIRECT®

Wiring Solutions using the ZIPLink Wiring System

ZIPLinks eliminate the normally tedious process of wiring between devices by utilizing prewired cables and DIN rail mount connector modules. It's as simple as plugging in a cable connector at either end or terminating wires at only one end. Prewired cables keep installation clean and efficient, using half the space at a fraction of the cost of standard terminal blocks. There are several wiring solutions available when using the ZIPLink System ranging from

PLC I/O-to-ZIPLink Connector Modules that are ready for field termination, options for connecting to third party devices, GS, DuraPulse and SureServo Drives, and specialty relay, transorb and communications modules. Pre-printed I/O-specific adhesive label strips for quick marking of ZIPLink modules are provided with ZIPLink cables. See the following solutions to help determine the best ZIPLink system for your application.

Solution 1: DirectLOGIC I/O Modules to ZIPLink Connector Modules

When looking for quick and easy I/O-to-field termination, a ZIPLink connector module used in conjunction with a prewired ZIPLink cable, consisting of an I/O terminal block at one end and a multi-pin connector at the other end, is the best solution.

Using the PLC I/O Modules to ZIPLink Connector Modules selector tables located in this section,

1. Locate your I/O module/PLC.
2. Select a ZIPLink Module.
3. Select a corresponding ZIPLink Cable.



Solution 2: DirectLOGIC I/O Modules to 3rd Party Devices

When wanting to connect I/O to another device within close proximity of the I/O modules, no extra terminal blocks are necessary when using the ZIPLink Pigtail Cables. ZIPLink Pigtail Cables are prewired to an I/O terminal block with color-coded pigtail with soldered-tip wires on the other end.

Using the I/O Modules to 3rd Party Devices selector tables located in this section,

1. Locate your PLC I/O module.
2. Select a ZIPLink Pigtail Cable that is compatible with your 3rd party device.



Solution 3: GS Series and DuraPulse Drives Communication Cables

Need to communicate via Modbus RTU to a drive or a network of drives?

ZIPLink cables are available in a wide range of configurations for connecting to PLCs and SureServo, SureStep, Stellar Soft Starter and AC drives. Add a ZIPLink communications module to quickly and easily set up a multi-device network.

Using the Drives Communication selector tables located in this section,

1. Locate your Drive and type of communications.
2. Select a ZIPLink cable and other associated hardware.





Wiring Solutions

Solution 4: Serial Communications Cables

ZIPLink offers communications cables for use with *Direct*LOGIC, CLICK, and Productivity3000 CPUs, that can also be used with other communications devices. Connections include a 6-pin RJ12 or 9-pin, 15-pin and 25-pin D-sub connectors which can be used in conjunction with the RJ12 or D-Sub Feedthrough modules.

Using the **Serial Communications Cables** selector table located in this section,

1. Locate your connector type
2. Select a cable.



Solution 5: Specialty ZIPLink Modules

For additional application solutions, *ZIPLink* modules are available in a variety of configurations including stand-alone relays, 24VDC and 120VAC transorb modules, D-sub and RJ12 feedthrough modules, communication port adapter and distribution modules, and SureServo 50-pin I/O interface connection.

Using the **ZIPLink Specialty Modules** selector table located in this section,

1. Locate the type of application.
2. Select a ZIPLink module.



Solution 6: ZIPLink Connector Modules to 3rd Party Devices

If you need a way to connect your device to terminal blocks without all that wiring time, then our pigtail cables with color-coded soldered-tip wires are a good solution. Used in conjunction with any compatible *ZIPLink* Connector Modules, a pigtail cable keeps wiring clean and easy and reduces troubleshooting time.

Using the **Universal Connector Modules and Pigtail Cables** table located in this section,

1. Select module type.
2. Select the number of pins.
3. Select cable.





PLC I/O Modules to ZIPLink Connector Modules - DL305



Company Information

Control Systems Overview

CLICK PLC

Do-More PLCs Overview

Do-More H2 PLC

Do-More T1H PLC

DirectLOGIC PLCs Overview

DirectLOGIC DL05/06

DirectLOGIC DL105

DirectLOGIC DL205

DirectLOGIC DL305

DirectLOGIC DL405

Productivity Controller Overview

Productivity 3000

Universal Field I/O

Software

C-More HMI

C-More Micro HMI

ViewMarq Industrial Marquees

Other HMI

Communications

Appendix Book 1

Terms and Conditions

DL305 PLC Input Module ZIPLink Selector				
PLC		ZIPLink		
Input Module	# of Terms	Component	Module Part No.	Cable Part No.
D3-08ND2 ¹	10	See Note 1		
D3-16ND2-1	18	Feedthrough	ZL-RTB20	ZL-D3-CBL18 *
F3-16ND3F	18	Feedthrough	ZL-RTB20	ZL-D3-CBL18 *
D3-08NA-1 ¹	10	See Note 1		
D3-08NA-2 ¹	10	See Note 1		
D3-16NA	18	Feedthrough	ZL-RTB20	ZL-D3-CBL18 *
D3-08NE3 ¹	10	See Note 1		
D3-16NE3	18	Feedthrough	ZL-RTB20	ZL-D3-CBL18 *
		Sensor	ZL-LTB16-24	ZL-D3-CBL18 *

DL305 PLC Output Module ZIPLink Selector				
PLC		ZIPLink		
Output Module	# of Terms	Component	Module Part No.	Cable Part No.
D3-04TD1 ¹	10	See Note 1		
D3-08TD1 ¹	10	See Note 1		
D3-08TD2 ¹	10	See Note 1		
D3-16TD1-1	18	Feedthrough	ZL-RTB20	ZL-D3-CBL18 *
		Fuse	ZL-RFU20 ⁴	ZL-D3-CBL18 *
		Relay (sinking)	ZL-RR16-24-1	ZL-D3-CBL18 *
D3-16TD2	18	Feedthrough	ZL-RTB20	ZL-D3-CBL18 *
		Fuse	ZL-RFU20 ⁴	ZL-D3-CBL18 *
		Relay (sourcing)	ZL-RR16-24-2	ZL-D3-CBL18 *
D3-04TAS ¹	10	See Note 1		
F3-08TAS-1	18	Feedthrough	ZL-RTB20	ZL-D3-CBL18 *
D3-08TA-1	18	Feedthrough	ZL-RTB20	ZL-D3-CBL18 *
D3-08TA-2 ¹	10	See Note 1		
F3-16TA-2	18	Feedthrough	ZL-RTB20	ZL-D3-CBL18 *
		Fuse	ZL-RFU20 ⁴	ZL-D3-CBL18 *
D3-16TA-2	18	Feedthrough	ZL-RTB20	ZL-D3-CBL18 *
		Fuse	ZL-RFU20 ⁴	ZL-D3-CBL18 *
D3-08TR ¹	10	See Note 1		
D3-16TR ²	18	Feedthrough	ZL-RTB20	ZL-D3-CBL18 *
		Fuse	ZL-RFU20 ⁴	ZL-D3-CBL18 *
F3-08TRS-1 ²	18	Feedthrough	ZL-RTB20	ZL-D3-CBL18 *
F3-08TRS-2 ²	18	Feedthrough	ZL-RTB20	ZL-D3-CBL18 *

DL305 PLC Analog Module ZIPLink Selector				
PLC		ZIPLink		
Analog Module	# of Terms	Component	Module	Cable
F3-04ADS	18	Feedthrough	ZL-RTB20	ZL-D3-CBL18 *
F3-08AD-1	18	Feedthrough	ZL-RTB20	ZL-D3-CBL18 *
F3-16AD	18	Feedthrough	ZL-RTB20	ZL-D3-CBL18 *
F3-04DA-1	18	Feedthrough	ZL-RTB20	ZL-D3-CBL18 *
F3-04DAS	18	Feedthrough	ZL-RTB20	ZL-D3-CBL18 *
F3-08THM-J ³	T/C Wire Only	See Note 3		
F3-08THM-K ³	T/C Wire Only	See Note 3		



NOTE: ZIPLINK CONNECTOR MODULES SPECIFICATIONS FOLLOW THE COMPATIBILITY MATRIX TABLES. ZIPLINK CABLES SPECIFICATIONS ARE AT THE END OF THIS ZIPLINK SECTION.



* Select the cable length by replacing the * with: Blank = 0.5m, -1 = 1.0m, or -2 = 2.0m.

¹ These I/O modules have non-removable terminal blocks which can be terminated using the ZL-CBL24-1P or 2P pigtail cable and the ZL-RTB20 module of the ZIPLink wiring system.

² Caution: The D3-16TR, F3-08TRS-1 and F3-08TRS-2 relay outputs are derated not to exceed 2A per point and 4A per common when used with the ZIPLink wiring system.

³ The F3-08THM-J and F3-08THM-K modules are not supported by the ZIPLink wiring system.

⁴ Note: Fuses (5 x 20 mm) are not included. See Edison Electronic Fuse section for (5 x 20 mm) fuse. S500 and GMA electronic circuit protection for fast-acting maximum protection. S506 and GMC electronic circuit protection for time-delay performance. Ideal for inductive circuits.

To ensure proper operation, do not exceed the voltage and current rating of ZIPLink module. ZL-RFU20 = 2A per circuit; ZL-RFU40 = 400 mA per circuit.

Simulator Module

D3-08SIM Input Simulator \$109.00	
Inputs per Module	8
Base Power Required	10mA @ 9VDC 112mA max @ 24VDC
OFF to ON Response	4-15ms
ON to OFF Response	4-15ms
Terminal Type	None
Status Indicators	Switch side
Weight	3.0oz. (85g)

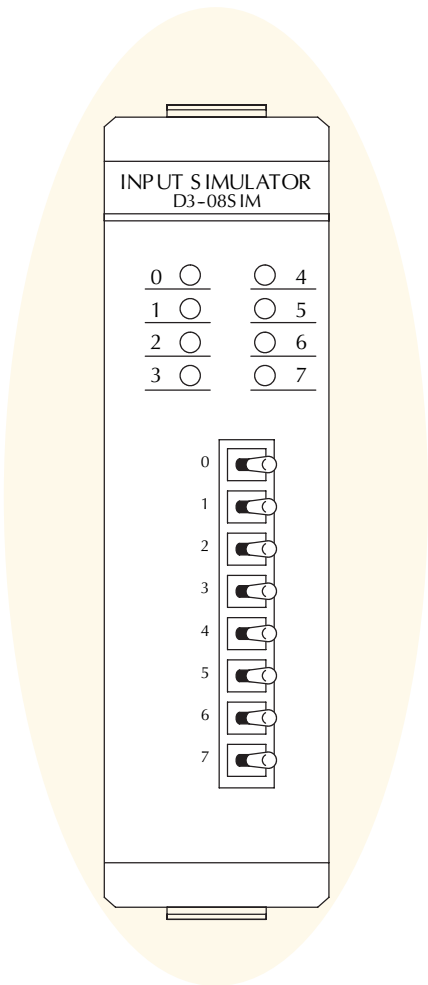

DC Input Modules

D3-08ND2 DC Input \$102.00	
Inputs per Module	8 (current sourcing)
Commons per Module	2 (internally connected)
Input Voltage Range	18-36VDC
Input Voltage	Internally supplied
Peak Voltage	40VDC
AC Frequency	N/A
ON Voltage Level	>18V
OFF Voltage Level	<3V
Input Impedance	1.8Kohm
Input Current	12mA max
Minimum ON Current	7mA
Maximum OFF Current	3mA
Base Power Required	9V 10mA max. 24V 14mA/ON pt. (112mA max)
OFF to ON Response	4-15ms
ON to OFF Response	4-15ms
Terminal Types	Non-removable
Status Indicators	Field side
Weight	4.2oz. (120g)

D3-16ND2-1 DC Input \$155.00	
Inputs per Module	16 (current sourcing)
Commons per Module	2 (internally connected)
Input Voltage Range	18-36VDC
Input Voltage	Internally supplied
Peak Voltage	36VDC
AC Frequency	N/A
ON Voltage Level	>19V
OFF Voltage Level	<3V
Input Impedance	1.8Kohm
Input Current	20mA Max
Minimum ON Current	5mA
Maximum OFF Current	1mA
Base Power Required	9V 25mA Max 24V 14mA/ON pt. (224mA max)
OFF to ON Response	3-15ms
ON to OFF Response	4-15ms
Terminal Types	Removable
Status Indicators	Field side
Weight	6.3oz. (180g)

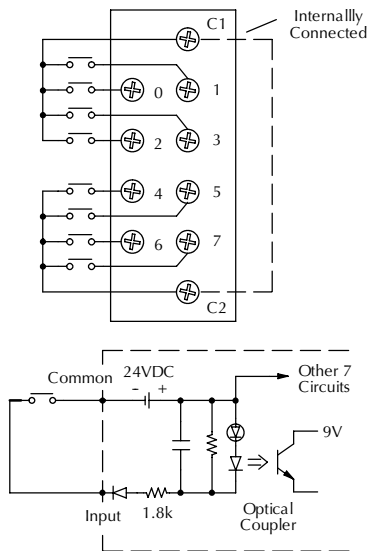
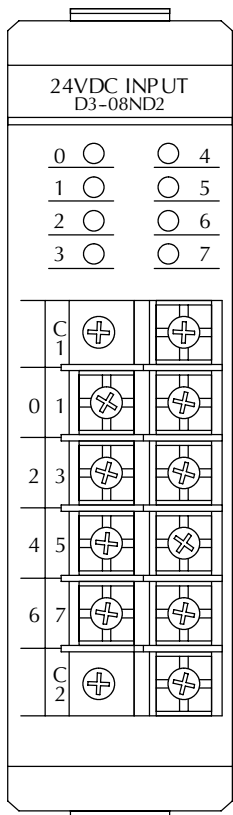
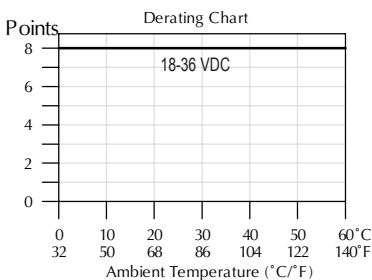

See page D3-29 for part numbers of ZIPLink cables and connection modules compatible with this I/O module.

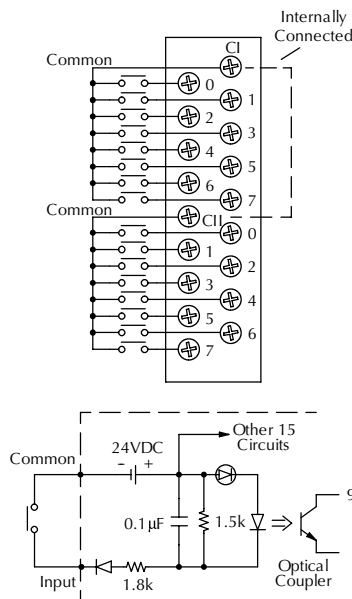
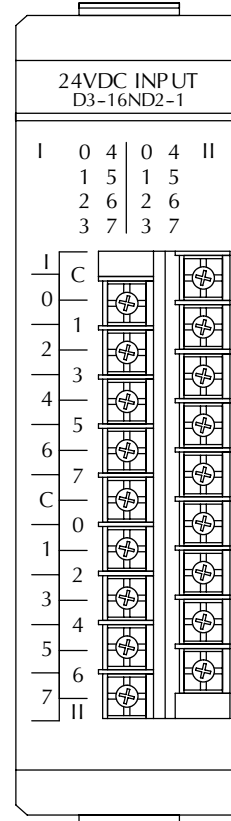
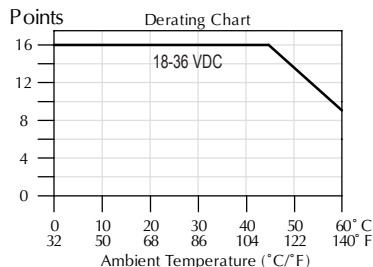

DC Input Modules

F3-16ND3F DC Fast Response Input \$174.00	
Inputs per Module	16 sink/source (jumper selectable sink/source)*
Commons per Module	2 (internally connected)
Input Voltage Range	5VDC TTL and CMOS, 12-24VDC (jumper selectable)*
Input Voltage Supplied	Internal (used with sinking loads) External (used with sourcing loads)
Peak Voltage	100VDC (35VDC Continuous)
AC Frequency	N/A
ON Voltage Level	3.5-5VDC @ 5VDC 10-24VDC @ 12-24VDC
OFF Voltage Level	0-1.5VDC @ 5VDC 0-4VDC @ 12-24VDC
Base Power Required	9V 148mA max 24V 69mA max
Input Current	1mA @ 5VDC 3mA @ 12-24VDC
Input Impedance	4.7K
OFF to ON Response	1ms
ON to OFF Response	1ms
Maximum Input Rate	500Hz
Minimum ON Current	0.4mA @ 5VDC 0.9mA @ 12-24VDC
Maximum OFF Current	0.8mA @ 5VDC 2.2mA @ 12-24VDC
Terminal Type	Removable
Status Indicators	Logic side
Weight	5.4oz. (153g)

Selection of operating mode

The DC power is provided by the rack power supply to sense the state of the inputs when jumpers are installed for sinking type signals. Sinking type inputs are turned ON by switching the input circuit to common. Source type input signals assume the ON state until the input device provides the voltage to turn the input OFF.

The mode of operation, either 5 VDC or 12-24 VDC sink or source, for each group of circuits is determined by the position of jumper plugs on pins that are located on the bottom edge of the circuit board. There are four sets of pins (3 pins in each set), with two sets for each group of inputs. The first two sets of pins are used to configure the first 12 inputs (e.g. 0 to 7 and 100 to 103) and are labeled 12 CIRCUITS. Above the first set of pins are the labels 12/24 V and 5 V. Above the second set of pins are the labels SINK and SRC (source). To select an operating mode for the first 12 circuits, place a jumper on the two pins nearest the appropriate labels. For example, to select 24 VDC Sink input operation for the first 12 inputs, place a jumper on the two pins labeled 12/24 V and on the two pins labeled SINK. The last two sets of pins are used to configure the last 4 inputs (eg. 104 to 107) and are labeled four CIRCUITS. The operating mode selected for the last group of four inputs can be different than the mode chosen for the first group of 12 inputs. Correct module operation required that each set of three pins have a jumper installed (four jumpers total).

***NOTE: When a group of inputs is used with TTL logic, select the SINK operating mode for that group. "Standard" TTL can sink several milliamps but can source less than 1 mA.**

See page D3-29 for part numbers of ZIPLink cables and connection modules compatible with this I/O module.

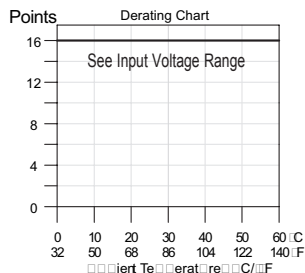
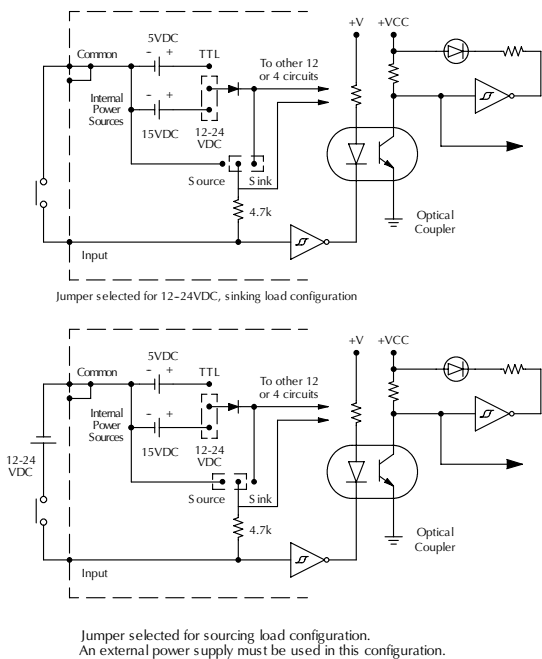

2 Inputs are selectable for 5VDC/12-24VDC and in Load/Source Load
4 Inputs are selectable for 5VDC/12-24VDC and in Load/Source Load

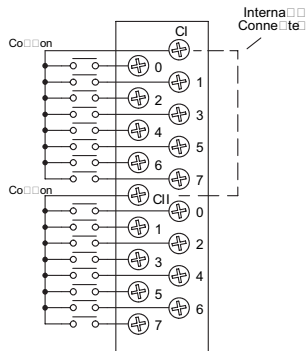

Input Load Configuration

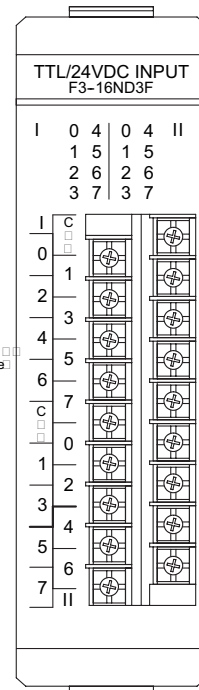

AC Input Modules

Company Information

Control Systems Overview

CLICK PLC

Do-More PLCs Overview

Do-More H2 PLC

Do-More T1H PLC

DirectLOGIC PLCs Overview

DirectLOGIC DL05/06

DirectLOGIC DL105

DirectLOGIC DL205

DirectLOGIC DL305

DirectLOGIC DL405

Productivity Controller Overview

Productivity 3000

Universal Field I/O

Software

C-More HMI

C-More Micro HMI

ViewMarq Industrial Marquees

Other HMI

Communications

Appendix Book 1

Terms and Conditions

D3-08NA-1 AC Input \$148.00	
Inputs per Module	8
Commons per Module	2 (isolated)
Input Voltage Range	85-132VAC
Input Voltage Supply	External
Peak Voltage	132VAC
AC Frequency	47-63Hz
ON Voltage Level	>80VAC
OFF Voltage Level	<20VAC
Input Impedance	10 K ohm
Input Current	15 mA @ 50Hz 18 mA @ 60Hz
Minimum ON Current	8mA
Maximum OFF Current	2mA
Base Power Required	9V 10mA max 24V N/A
OFF to ON Response	10-30ms
ON to OFF Response	10-60ms
Terminal Types	Non-removable
Status Indicators	Field side
Weight	5oz. (140g)

D3-08NA-2 AC Input \$101.00	
Inputs per Module	8
Commons per Module	2 (isolated)
Input Voltage Range	180-265VAC
Input Voltage Supply	External
Peak Voltage	265 VAC
AC Frequency	50-60Hz
ON Voltage Level	>180VAC
OFF Voltage Level	<40VAC
Input Impedance	18Kohm
Input Current	13mA @ 50Hz 18mA @ 60Hz
Minimum ON Current	10mA
Maximum OFF Current	2mA
Base Power Required	9V 10mA max 24V N/A
OFF to ON Response	5-50ms
ON to OFF Response	5-60ms
Terminal Types	Non-removable
Status Indicators	Field side
Weight	5oz. (140g)

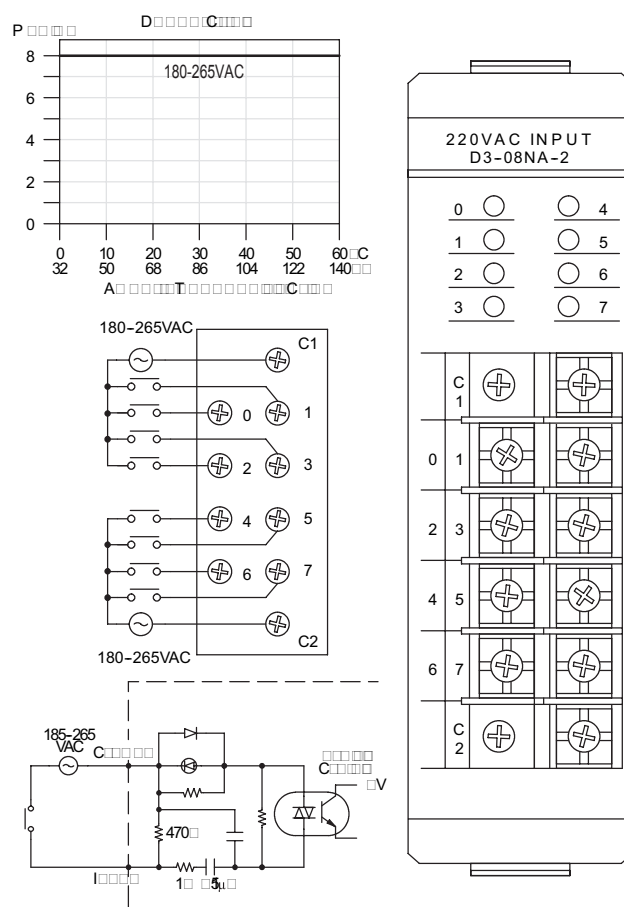
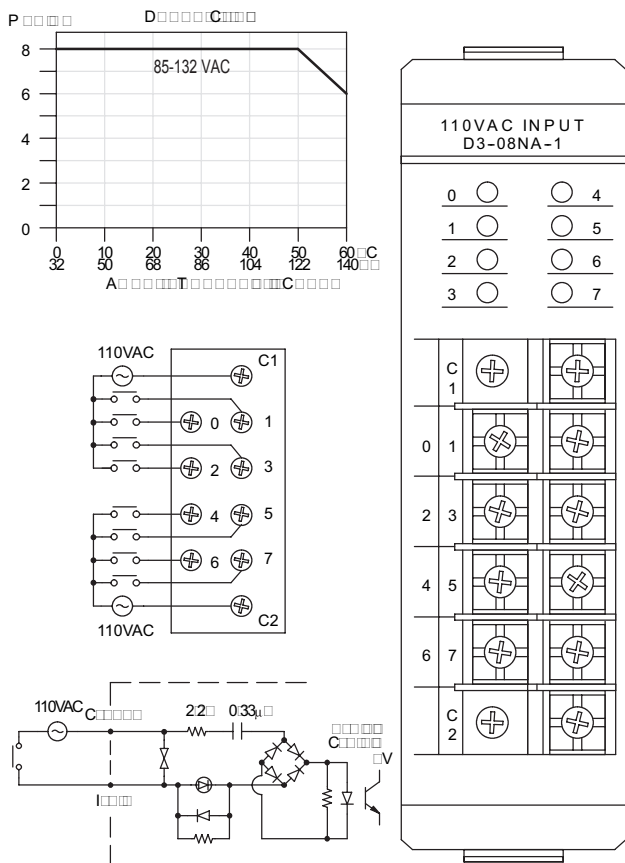

AC Input and AC/DC Input Modules

D3-16NA AC Input \$229.00	
Inputs per Module	16
Commons per Module	2 (isolated)
Input Voltage Range	80-132VAC
Input Voltage Supply	External
Peak Voltage	132VAC
AC Frequency	50-60Hz
ON Voltage Level	>80 VAC
OFF Voltage Level	<15 VAC
Input Impedance	8 K ohm
Input Current	16mA @ 60Hz 24mA @ 60 Hz
Minimum ON Current	8mA
Maximum OFF Current	1.5mA
Base Power Required*	9V 6.25mA max/ON pt 100 mA max
OFF to ON Response	5-50ms
ON to OFF Response	5-60ms
Terminal Types	Removable
Status Indicators	Logic side
Weight	6.4oz. (189g)

*9V typical values are 4mA/ON pt., 64mA total

D3-08NE3 AC/DC Input \$114.00	
Inputs per Module	8 (sink/source)
Commons per Module	2 (isolated)
Input Voltage Range	20-28VAC/VDC
Input Voltage	External
Peak Voltage	28VAC/VDC
AC Frequency	47-63Hz
ON Voltage Level	>20V
OFF Voltage Level	<6V
Input Impedance	1.5Kohm
Input Current	19mA max
Minimum ON Current	10mA
Maximum OFF Current	2mA
Base Power Required	9V 10mA max 24V N/A
OFF to ON Response	AC: 5-50ms DC: 6-30ms
ON to OFF Response	AC/DC: 5-60ms
Terminal Type	Non-removable
Status Indicators	Field side
Weight	4.2oz. (120g)

See page D3-29 for part numbers of ZIPLink cables and connection modules compatible with this I/O module.

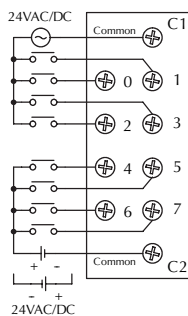
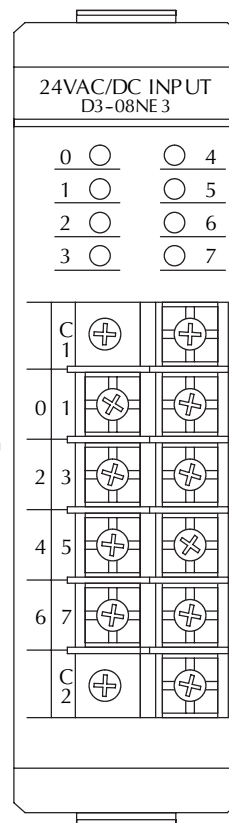
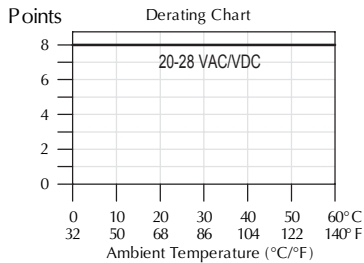
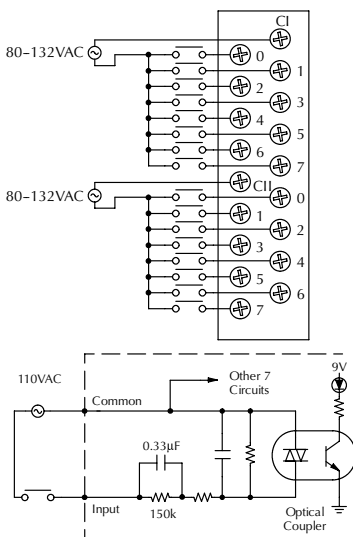
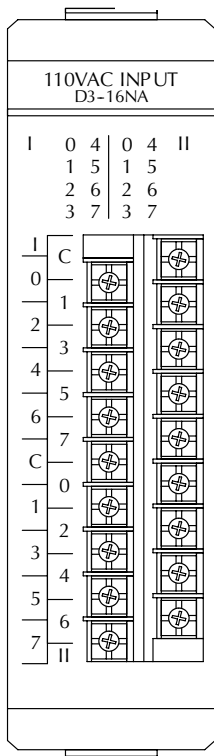
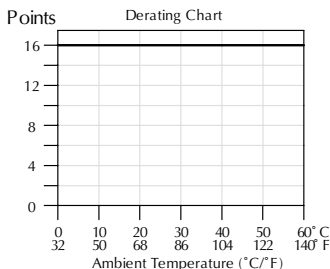

NOTE: This module can be wired in a sourcing configuration and it will be operational except there will be no module LED indication for each input.

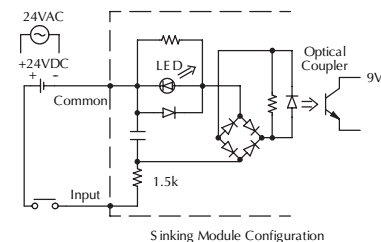

AC/DC Input Modules

D3-16NE3 AC/DC Input \$154.00	
Inputs per Module	16 (sink/source)
Commons per Module	2 (isolated)
Input Voltage Range	14-30VAC/VDC
Input Voltage	External
Peak Voltage	30VAC/VDC
AC Frequency	47-63Hz
ON Voltage Level	>14V
OFF Voltage Level	<3V
Input Impedance	1.8Kohm
Input Current	16mA Max
Minimum ON Current	7mA
Maximum OFF Current	2mA
Base Power Required	9V 2.5mA+4.5mA/ON pt. (130mA max) 24V N/A
OFF to ON Response	AC 5-30ms DC 5-25 ms
ON to OFF Response	AC 5-30ms DC 5-25 ms
Terminal Type	Removable
Status Indicators	Logic side
Weight	6oz. (170g)

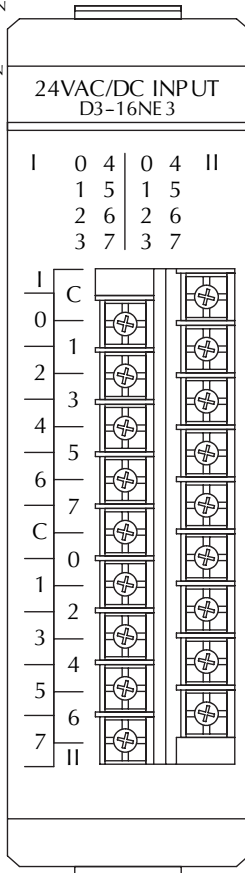
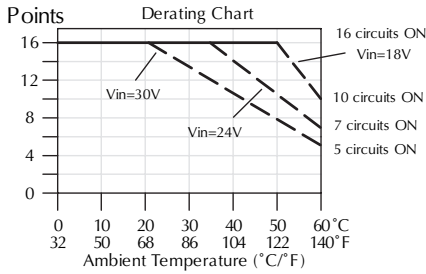

See page D3-29 for part numbers of ZIPLink cables and connection modules compatible with this I/O module.

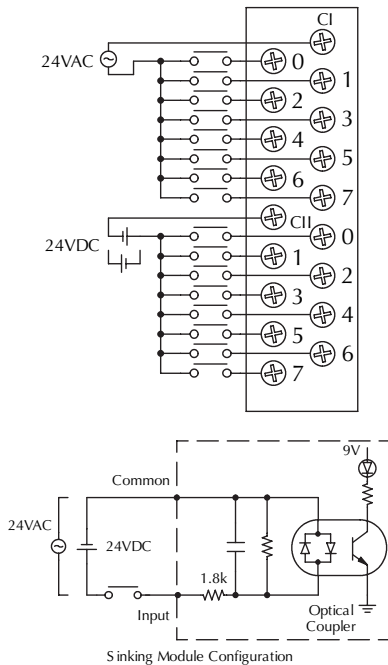

Company Information

Control Systems Overview

CLICK PLC

Do-More PLCs Overview

Do-More H2 PLC

Do-More T1H PLC

DirectLOGIC PLCs Overview

DirectLOGIC DL05/06

DirectLOGIC DL105

DirectLOGIC DL205

DirectLOGIC DL305

DirectLOGIC DL405

Productivity Controller Overview

Productivity 3000

Universal Field I/O

Software

C-More HMI

C-More Micro HMI

ViewMarq Industrial Marquees

Other HMI

Communications

Appendix Book 1

Terms and Conditions

DC Output Modules

D3-04TD1 DC Output \$114.00	
Outputs per Module	4 (current sinking)
Commons per Module	4 (internally connected)
Operating Voltage	5-24VDC
Output Type	Field effect transistor
Peak Voltage	45VDC
AC Frequency	N/A
ON Voltage Drop	0.9V @ 6A
Max. Current	2A/point 6A/module
Max Leakage Current	0.4mA @ 40VDC
Max Inrush Current	6A/100ms
Minimum Load	5mA
Base Power Required	9V 12mA/pt (48mA Max) 24V 5mA
OFF to ON Response	0.1ms
ON to OFF Response	0.1ms
Terminal Type	Non-removable
Status Indicators	Logic side
Weight	4.2oz. (120g)
Fuses	4 (one 5A per common) user replaceable

D3-08TD1 DC Output \$114.00	
Outputs per Module	8 (current sinking)
Commons per Module	2 (internally connected)
Operating Voltage	5-24VDC
Output Type	NPN (open collector)
Peak Voltage	45VDC
AC Frequency	N/A
ON Voltage Drop	0.8V @ 0.5A
Max. Current	0.5A/point 1.8/common
Max Leakage Current	0.1mA @ 40VDC
Max Inrush Current	3A/20ms 1A/100ms
Minimum Load	1mA
Base Power Required	9V 20mA max 24V 3mA/pt (24mA Max)
OFF to ON Response	0.1ms
ON to OFF Response	0.1ms
Terminal Type	Non removable
Status Indicators	Logic side
Weight	4.2oz. (120g)
Fuses	2 (one 3A per common) non-replaceable

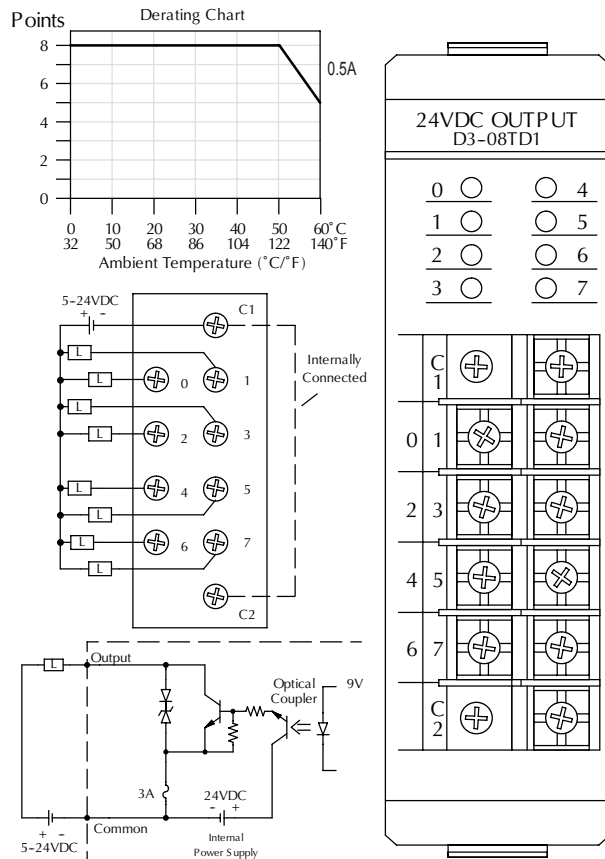
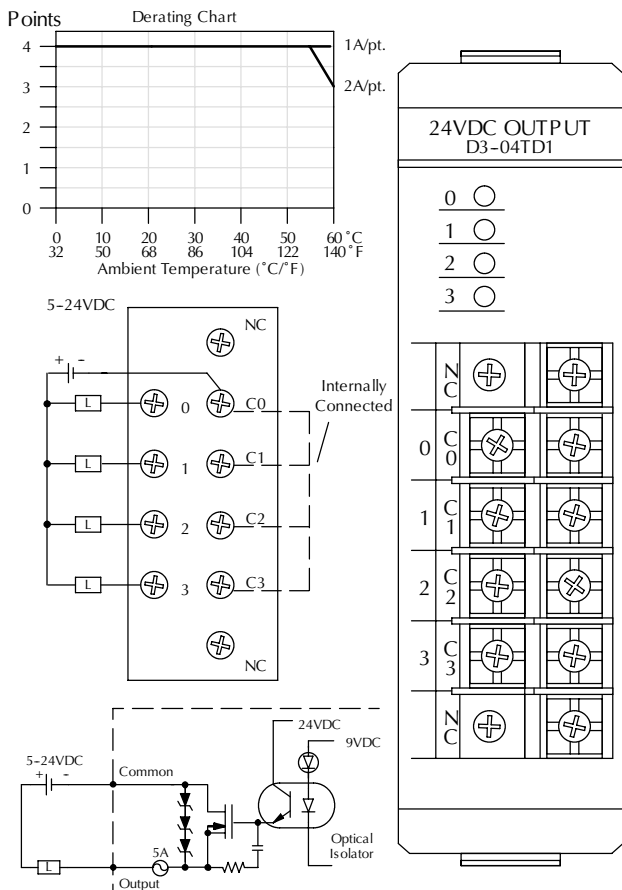

DC Output Modules

D3-08TD2 DC Output \$132.00	
Outputs per Module	8 (current sourcing)
Commons per Module	2 (internally connected)
Operating Voltage	5-24VDC
Output Type	NPN transistor (emitter follower)
Peak Voltage	40VDC
AC Frequency	N/A
ON Voltage Drop	1V @ 0.5A
Max. Current	0.5A/point 1.8A/common
Max Leakage Current	0.1mA @ 24VDC
Max Inrush Current	3A/20ms 1A/100ms
Minimum Load	1mA
Base Power Required	9V 30mA max 24V N/A
OFF to ON Response	0.1ms
ON to OFF Response	0.1ms
Terminal Type	Non-removable
Status Indicators	Logic side
Weight	4.2oz. (120 g)
Fuses	2 (one 3A per common) non-replaceable

D3-16TD1-1 DC Output \$217.00	
Outputs per Module	16 (current sinking)
Commons per Module	2 (internally connected)
Operating Voltage	5-24VDC
Output Type	NPN transistor (open collector)
Peak Voltage	45VDC
AC Frequency	N/A
ON Voltage Drop	2V @ 0.5A
Max. Current	0.5A/point 2A/common
Max Leakage Current	0.1mA @ 40VDC
Max Inrush Current	3A/20ms 1A/100ms
Minimum Load	1mA
Base Power Required	9V (40mA max) 3mA+2.3mA/ON pt. 24V 6mA/ON pt. (96mA max)
OFF to ON Response	0.1ms
ON to OFF Response	0.1ms
Terminal Type	Removable
Status Indicator	Logic side
Weight	5.6oz. (160g)
Fuses	2 (one 3A per common) non-replaceable

Company Information

Control Systems Overview

CLICK PLC

Do-More PLCs Overview

Do-More H2 PLC

Do-More T1H PLC

DirectLOGIC PLCs Overview

DirectLOGIC DL05/06

DirectLOGIC DL105

DirectLOGIC DL205

DirectLOGIC DL305

DirectLOGIC DL405

Productivity Controller Overview

Productivity 3000

Universal Field I/O

Software

C-More HMI

C-More Micro HMI

ViewMarq Industrial Marquees

Other HMI

Communications

Appendix Book 1

Terms and Conditions

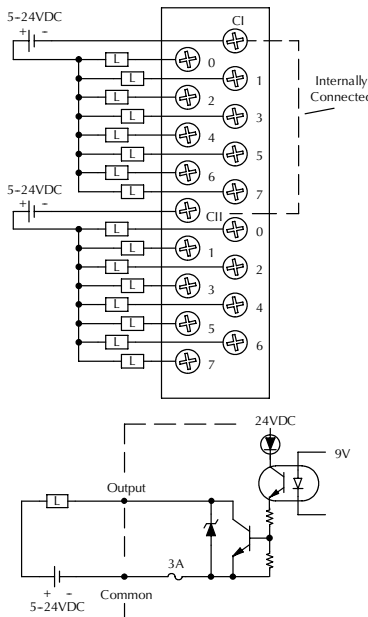
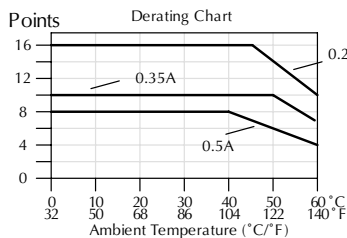
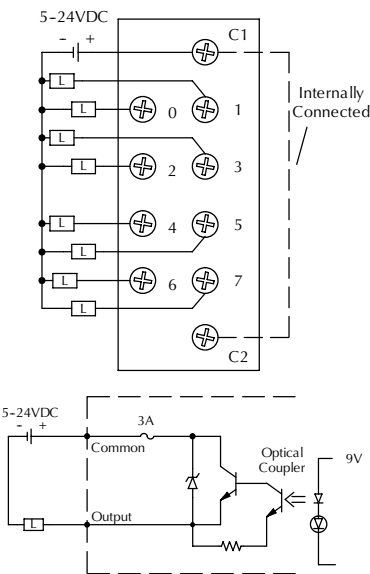
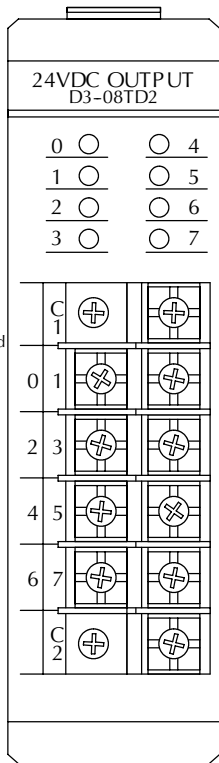
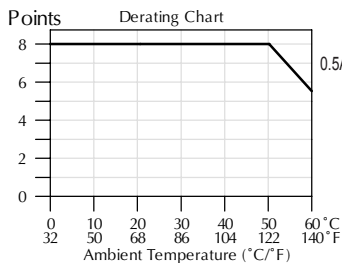

DC Output Modules

D3-16TD2 DC Output \$217.00	
Outputs per Module	16 (current sourcing)
Commons per Module	2 (isolated)
Operating Voltage	5-24VDC
Output Type	NPN transistor (emitter follower)
Peak Voltage	40VDC
AC Frequency	N/A
ON Voltage Drop	1.5V @ 0.5A
Max. Current	0.5A/point 3A/common
Max Leakage Current	0.01mA @ 40VDC
Max Inrush Current	3A/20ms 1A/100ms
Minimum Load	1mA
Base Power Required	9V (180mA max) 7.5mA/ON pt. 24V N/A
OFF to ON Response	0.1ms
ON to OFF Response	0.1ms
Terminal Type	Removable connector
Status Indicators	Logic side
Weight	7.1oz.(210g)
Fuses	2 (one 5A per common) non-replaceable

See page D3-29 for part numbers of ZIPLink cables and connection modules compatible with this I/O module.

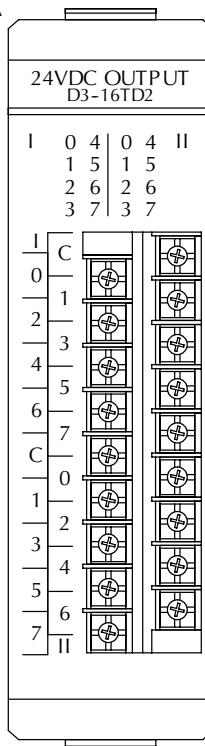
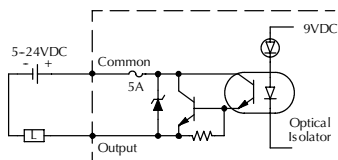
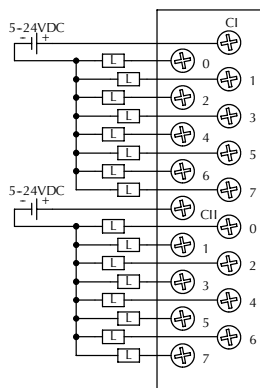
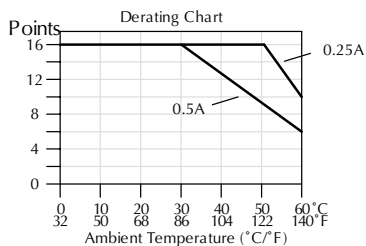

AC Output Modules

D3-04TAS AC Output \$137.00	
Outputs per Module	4
Commons per Module	4 (isolated)
Operating Voltage	80-265VAC
Output Type	Triac
Peak Voltage	265VAC
AC Frequency	47-63Hz
ON Voltage Drop	1.5VAC @ 2A
Max. Current	2A/point 2A/common
Max Leakage Current	7mA @ 220VAC 3.5mA @ 110VAC
Max Inrush Current	20A for 16ms 10A for 100ms
Minimum Load	10mA
Base Power Required	9V 12mA max 24V N/A
OFF to ON Response	1ms max
ON to OFF Response	10ms max
Terminal Type	Non-removable
Status Indicators	Logic side
Weight	6.4oz. (180g)
Fuses	4 (1 per common) 3A Order D3-FUSE-2 (5 per pack) \$3.25

F3-08TAS-1 AC Output \$218.00	
Outputs per Module	8 (1500V point to point isolation)
Commons per Module	8 (isolated)
Operating Voltage	20-125VAC
Output Type	SSR (Triac with zero cross-over)
Peak Voltage	140VAC
AC Frequency	47-63Hz
ON Voltage Drop	1.6V(rms) @ 1.5A
Maximum Current	1.5A/point
Maximum Leakage Current	0.7mA(rms)
Max Inrush Current	15A for 20ms 8A for 100ms
Minimum Load	50mA
Base Power Required	9V 25mA/VON pt (200mA max), 24V N/A
OFF to ON Response	1ms max
ON to OFF Response	9ms max
Terminal Type	Removable
Status Indicators	Logic side
Weight	6.3oz. (177g)
Fuses	8 (1 per common) 5A, 125V fast blow Order D3-FUSE-4 (5 per pack) \$14.00

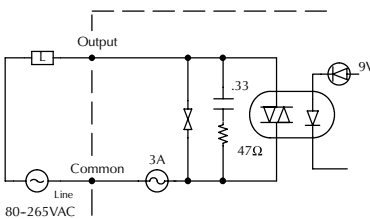
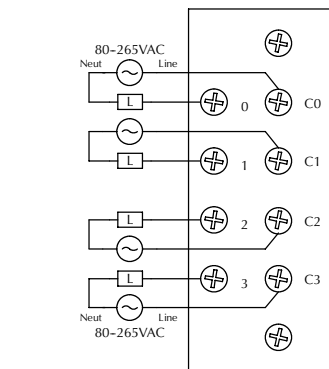
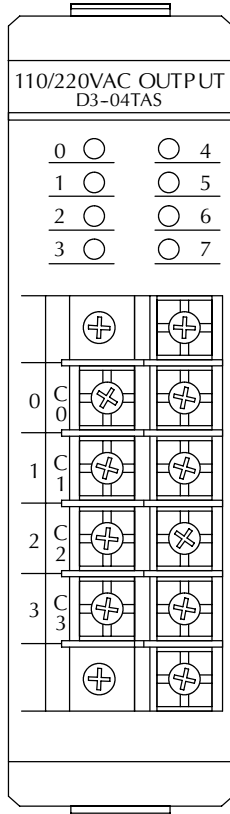
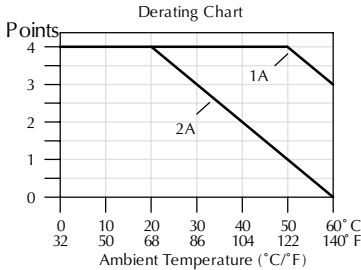

See page D3-29 for part numbers of ZIPLink cables and connection modules compatible with this I/O module.

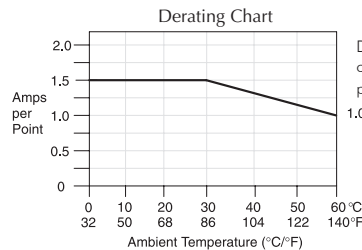

Derating Note: All outputs can be run at the current per point shown.

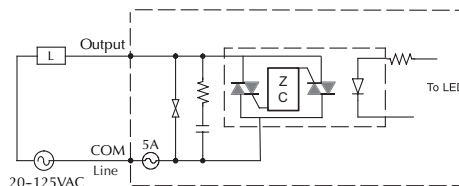
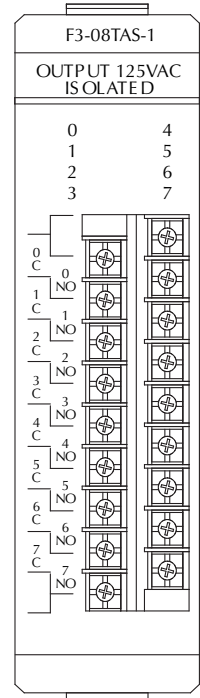
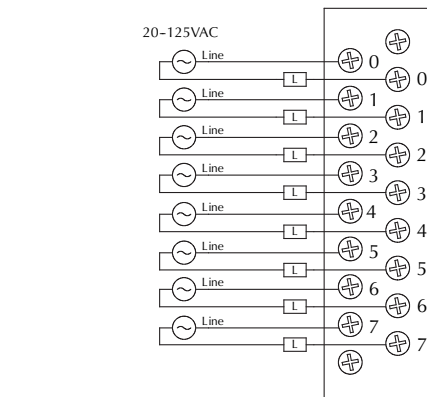

AC Output Modules

D3-08TA-1 AC Output \$258.00	
Outputs per Module	8
Commons per Module	2 (isolated)
Operating Voltage	80-265VAC
Output Type	Triac
Peak Voltage	265VAC
AC Frequency	47-63Hz
ON Voltage Drop	1.5 VAC @ 1A
Max. Current	1A/point 3A/common
Max Leakage Current	1.2mA @ 220VAC 0.52mA @ 110VAC
Max Inrush Current	10A for 16ms 5A for 100ms
Minimum Load	25mA
Base Power Required	9V 20mA/ON pt. (160mA Max) 24V N/A
OFF to ON Response	1ms max
ON to OFF Response	8.33ms max
Terminal Type	Removable
Status Indicators	Logic side
Weight	7.4oz. (210g)
Fuses	2 (one 5A per common) non-replaceable

D3-08TA-2 AC Output \$240.00	
Outputs per Module	8
Commons per Module	2 (isolated)
Operating Voltage	80-265VAC
Output Type	Triac
Peak Voltage	265VAC
AC Frequency	47-63Hz
ON Voltage Drop	1.5 VAC @ 1A
Max. Current	1A/point 3A/common
Max Leakage Current	1.2mA @ 220VAC 0.52mA @ 110VAC
Max Inrush Current	10A for 16ms 5A for 100ms
Minimum Load	25mA
Base Power Required	9V 20mA/ON pt. (160mA Max) 24V N/A
OFF to ON Response	1ms max
ON to OFF Response	8.33ms max
Terminal Type	Non-removable
Status Indicators	Logic side
Weight	6.4oz. (180g)
Fuses	2 (one 5A per common) non-replaceable

See page D3-29 for part numbers of ZIPLink cables and connection modules compatible with this I/O module.

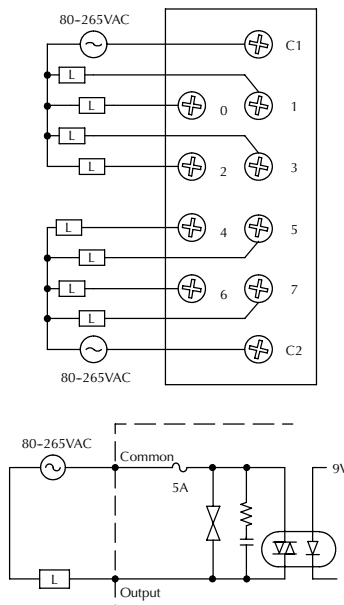
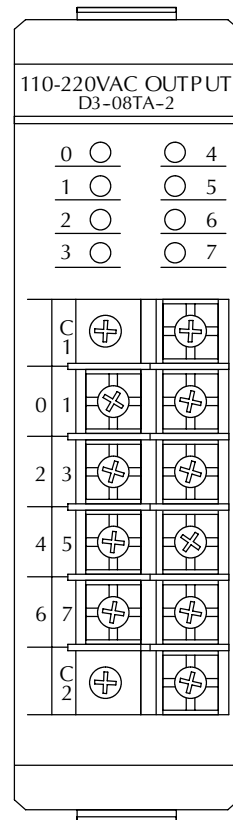
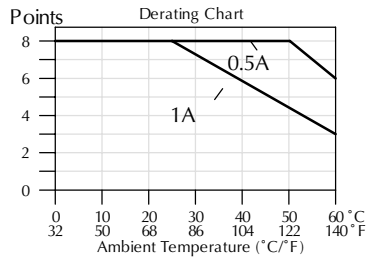
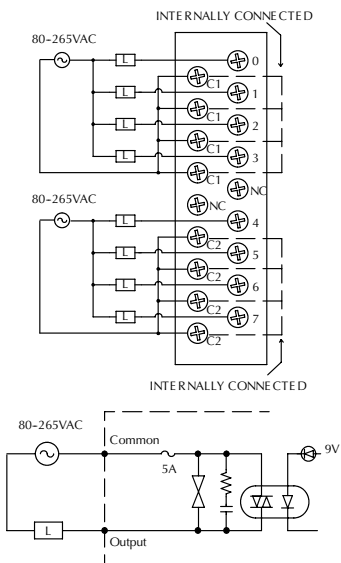
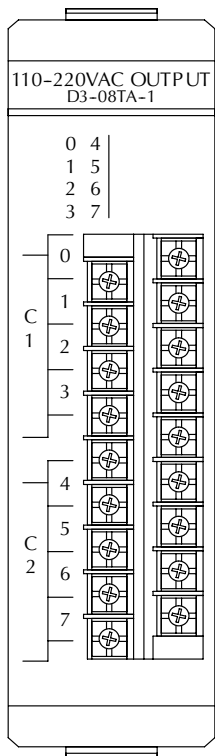
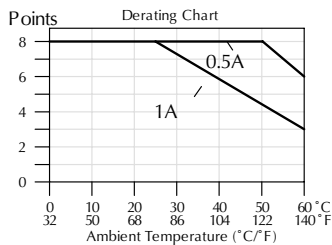

AC Output Modules

F3-16TA-2 AC Output \$286.00	
Outputs per Module	16
Commons per Module	2 (isolated)
Operating Voltage	20-125VAC
Output Type	SSR Array (TRIAC)
Peak Voltage	140VAC
AC Frequency	47-63Hz
ON Voltage Drop	1.1VAC @ 1.1A
Max. Current	1.1A/point
Max Leakage Current	0.7mA @ 125VAC
Max Inrush Current*	15A for 20ms 8A for 100ms
Minimum Load	50mA
Base Power Required	9V 14mA / ON pt. 250mA Max. 24V N/A
OFF to ON Response	8ms max
ON to OFF Response	8ms max
Terminal Type	Removable
Status Indicators	Logic side
Weight	7.7oz. (218g)
Fuses (One spare fuse included)	4 (One 5A 125V fast blow per each group of four outputs) Order D3-FUSE-4 (5 per pack) \$14.00

See page D3-29 for part numbers of ZIPLink cables and connection modules compatible with this I/O module.

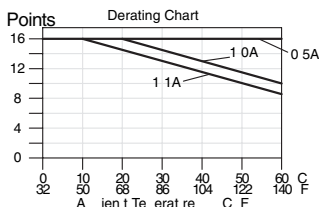

Fuse size at 20A surge motor starters to an inductive load is 3A and use it in this case.

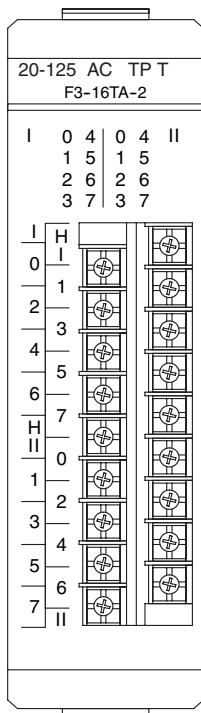
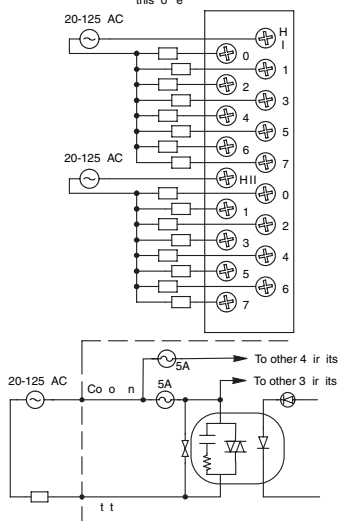

D3-16TA-2 AC Output \$321.00	
Outputs per Module	16
Commons per Module	2 (isolated)
Operating Voltage	15-265VAC
Output Type	Triac
Peak Voltage	265VAC
AC Frequency	47-63Hz
ON Voltage Drop	1.5VAC @ 0.5A
Max. Current	0.5A/point 3A/common 6A/per module
Max Leakage Current	4 mA @ 265VAC
Max Inrush Current	10A for 10ms 5A for 100ms
Minimum Load	10 mA @ 15VAC
Base Power Required*	9V 25mA max/ON pt. 400mA max 24V N/A
OFF to ON Response	1ms max
ON to OFF Response	9ms max
Terminal Type	Removable
Status Indicators	Logic side
Weight	7.2oz (210g)
Fuses	2 (One 5A per common) non-replaceable

See page D3-29 for part numbers of ZIPLink cables and connection modules compatible with this I/O module.

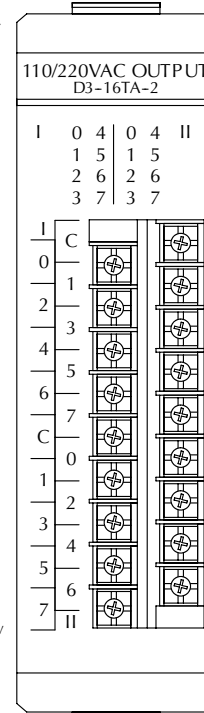
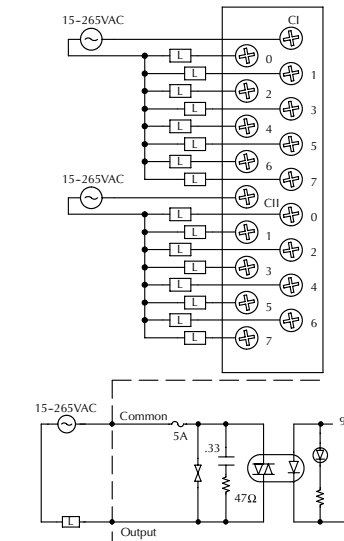
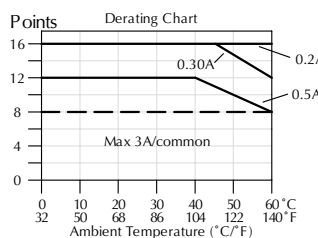

Note: When used with the ZIPLink wiring system, relay outputs are derated not to exceed 2 Amps per point max.

Relay Output Modules

D3-08TR Relay Output \$160.00	
Outputs per Module	8
Commons per Module	2 (isolated)
Operating Voltage	5-265VAC 5-30VDC
Output Type	Form A (SPST)
Peak Voltage	265VAC/30VDC
AC Frequency	47-63Hz
ON Voltage Drop	N/A
Max. Current	4A/point AC 5A/point DC 6A/common
Max Leakage Current	1mA @ 220VAC
Max Inrush Current	5A
Minimum Load	5mA @ 5V
Base Power Required	9V 45mA/ON pt. (360 mA max) 24V N/A
OFF to ON Response	5ms
ON to OFF Response	5 ms
Terminal Type	Non-removable
Status Indicators	Logic side
Weight	7oz. (200g)
Fuses	2 (one 10A per common) Order D3-FUSE-5 (5 per pack) \$45.00

D3-16TR Relay Output \$263.00	
Outputs per Module	16
Commons per Module	2 (isolated)
Operating Voltage	5-265VAC 5-30 VDC
Output Type	16 Form A (SPST)
Peak Voltage	265VAC/30VDC
AC Frequency	47-63Hz
ON Voltage Drop	N/A
Max. Current	2A/point AC/DC (resistive) 8A/common AC/DC*
Max Leakage Current	0.1mA @ 220VAC
Max Inrush Current	2A
Minimum Load	5mA @ 5V
Base Power Required	9V 30mA/ON pt. (480 mA max) 24V N/A
OFF to ON Response	12ms
ON to OFF Response	12ms
Terminal Type	Removable
Status Indicators	Logic side
Weight	8.5oz. (248g)
Fuses	None

See page D3-29 for part numbers of ZIPLink cables and connection modules compatible with this I/O module.

Note: When used with the ZIPLink wiring system, relay outputs are derated not to exceed 2 Amps per point max.

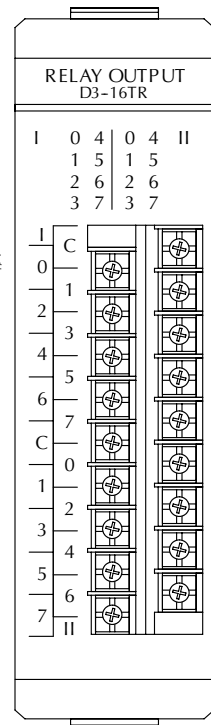
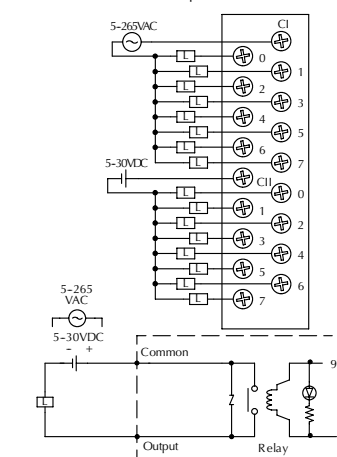
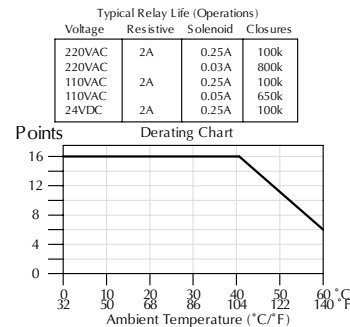
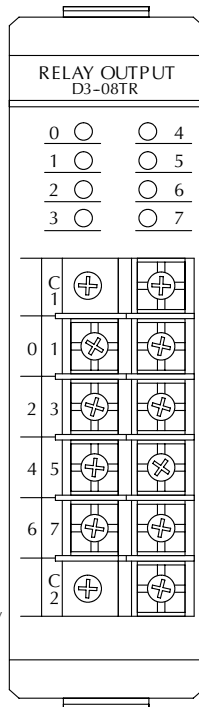
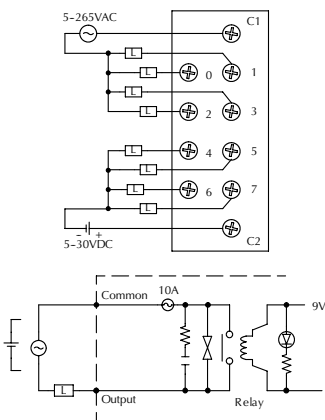
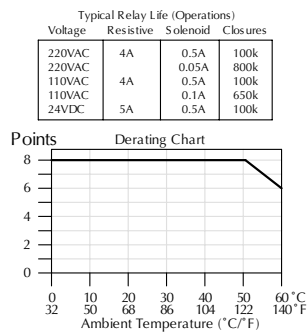

Relay Output Modules

F3-08TRS-1 Relay Output \$149.00	
Outputs per Module	8
Commons per Module	8 (isolated)
Operating Voltage*	12-125VAC 125-250VAC (requires external fuses) 12-30VDC
Output Type	6 Form A (SPST), 2 Form C (SPDT)
Max Current (resistive)	10A/point AC/DC, 32A/module AC/DC*
Max leakage Current	N/A
Max Inrush Current	10A inductive
Minimum Load	100mA @ 12VDC
Base Power Required	9V 37mA/ON pt., (296mA max), 24V N/A
OFF to ON Response	13ms max
ON to OFF Response	9ms max
Terminal Type	Removable
Status Indicators	Logic side
Weight	8.9oz. (252 g)
Fuses	8 fuses (10A, 125V), Non-replaceable
Peak Voltage	265VAC/120VDC
AC Frequency	47-63Hz
ON Voltage Drop	N/A

Max. Resistive or Inductive Inrush Load Current	Operating Voltage		
	28VDC	120VAC	240VAC
1/4HP		25K	
10.0A	50K	50K	
5.0A	200K	100K	
3.0A	325K	125K	50K
.05A	> 50M		

See page D3-29 for part numbers of ZIPLink cables and connection modules compatible with this I/O module.



Note: When used with the ZIPLink wiring system, relay outputs are derated not to exceed 2 Amps per point max.

* Caution: the ZIPLink wiring system is rated at 2 Amps per I/O point and 4 Amps per common, therefore the F3-08TRS-1 relay outputs are derated to 2 Amps per point and 4 Amps per common when used with the ZIPLink wiring system.

Note: Maximum DC voltage rating is 120VDC at .5 Amp, 30,000 cycles typical. Motor starters up to and including NEMA size 4 can be used with this module.

Derating Chart

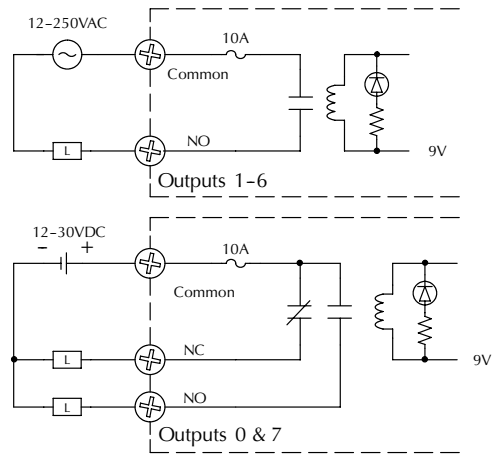
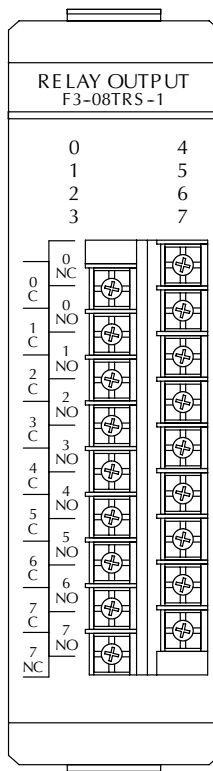
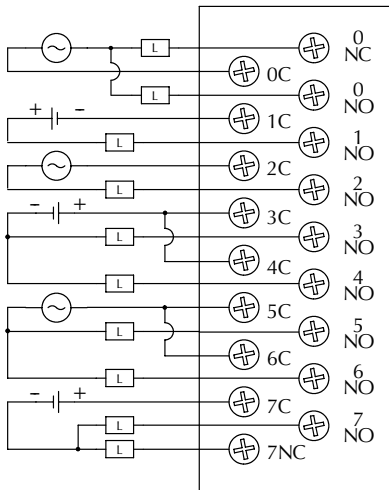
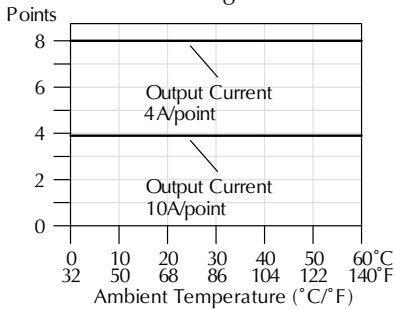

* Caution: the ZIPLink wiring system is rated at 2 Amps per I/O point and 4 Amps per common, therefore the D3-16TR relay outputs are derated to 2 Amps per point and 4 Amps per common when used with the ZIPLink wiring system.

Relay Output Modules

F3-08TRS-2 Relay Output \$161.00	
Outputs per Module	8
Commons per Module	8 (isolated)
Operating Voltage*	12-250VAC 12-30 VDC
Output Type	6 Form A (SPST), 2 Form C (SPDT)
Peak Voltage	265VAC/ 120VDC
AC Frequency	47-63Hz
ON Voltage Drop	N/A
Max Current (Resistive)	4A/point AC/DC, 32A/module AC/DC*
Max Leakage Current	N/A

Max Inrush Current	10A inductive
Minimum Load	100mA @ 12VDC
Base Power Required	9V 37mA/ON pt. (296 mA Max), 24V N/A
OFF to ON Response	13ms max
ON to OFF Response	9ms max
Terminal Type	Removable
Status Indicators	Logic side
Weight	9oz. (255 g)
Fuses	8 fuses (10A, 125V), replaceable Order D3-FUSE-6 (5 per pace) \$14.00 or use 19379-K-10A Wickman

* Caution: the ZIPLink wiring system is rated at 2 Amps per I/O point and 4 Amps per common, therefore the F3-08TRS-2 relay outputs are derated to 2 Amps per point and 4 Amps per common when used with the ZIPLink wiring system.

Note: Maximum DC voltage rating is 120VDC at 0.5 Amp, 30,000 cycles typical. Motor starters up to and including NEMA size 3 can be used with this module.

See page D3-29 for part numbers of ZIPLink cables and connection modules compatible with this I/O module.



Typical Relay Life			
Max. Resistive or Inductive Inrush Load Current	Operating Voltage		
	28VDC	120VAC	240VAC
5.0A	200K	100K	
3.0A	325K	125K	50K
0.5A	>50M		

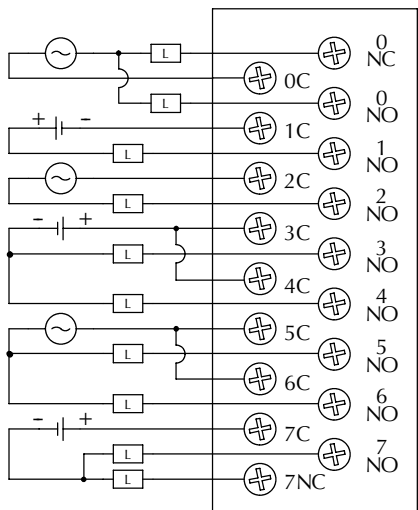
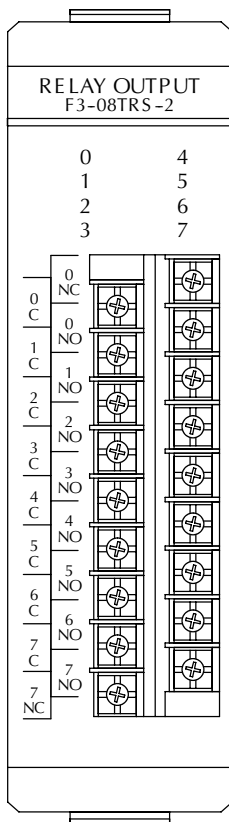
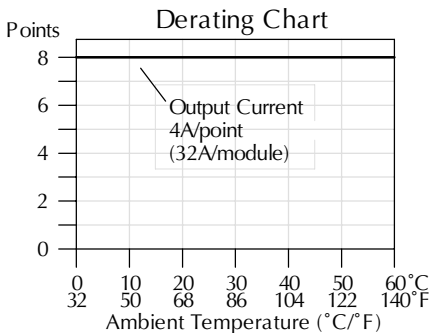

Expected mechanical relay life is 100 million operations.

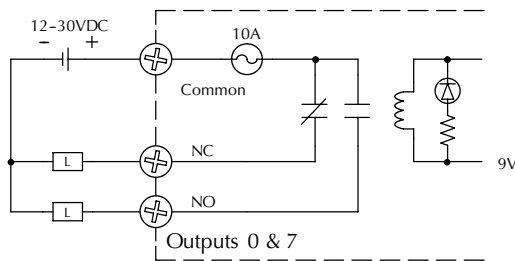
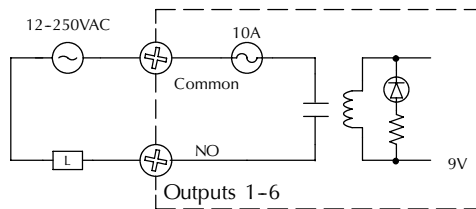

Analog Input Modules

F3-04ADS 4-Channel Isolated Analog Input \$689.00	
Number of Channels	4, (isolated)
Input Ranges	0-5V, 0-10V, 1-5V, $\pm 5V$, $\pm 10V$, 0-20mA, 4-20mA
Channels Individually Configured	Yes
Resolution	12 bit (1 in 4096)
Input Type	Differential
Max. Common Mode Voltage	$\pm 750V$ peak continuous transformer isolation
Noise Rejection Ratio	Common mode: -100dB at 60Hz
Active Low-pass Filtering	-3dB at 10Hz, -12dB per octave
Input Impedance	250ohm \pm 0.1%, 1/2W current input, 200Kohm voltage input
Absolute Maximum Ratings	± 40 mA, current input $\pm 100V$, voltage input
Conversion Time	1 channel per scan, successive approximation, AD574
Linearity Error	± 1 counts max. (0.03% of full scale) unipolar ± 2 counts max. (0.05% of full scale) bipolar
Full Scale Calibration Error	± 8 counts maximum

Offset Calibration Error	± 8 counts maximum
Accuracy vs. Temperature	57ppm/°C maximum full scale
Recommended Fuse	0.032A, Series 217 fast-acting, current inputs
Power Budget Requirement	183mA @ 9VDC, 50mA @ 24VDC
External Power Supply	None required
Operating Temperature	32° to 140°F (-0° to 60°C)
Storage Temperature	-4° to 158° F (-20° to 70°C)
Relative Humidity	5 to 95% (non-condensing)
Environmental Air	No corrosive gases permitted
Vibration	MIL STD 810C 514.2
Shock	MIL STD 810C 516.2
Noise Immunity	NEMA ICS3-304

See page D3-29 for part numbers of ZIPLink cables and connection modules compatible with this I/O module.



- Note 1:** Connect unused voltage or current inputs to 0VDC at terminal block or leave current jumper installed (see Channel 3).
- Note 2:** A Series 217, 0.032A, fast-acting fuse is recommended for 4-20mA current loops.
- Note 3:** Transmitters may be 2, 3, or 4 wire type.
- Note 4:** Transmitters may be powered from separate power sources.
- Note 5:** Terminate all shields of the cable at their respective signal source.

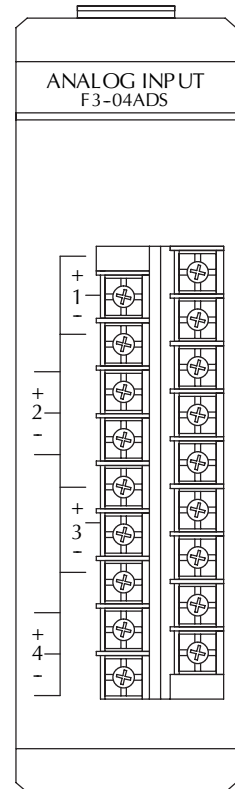
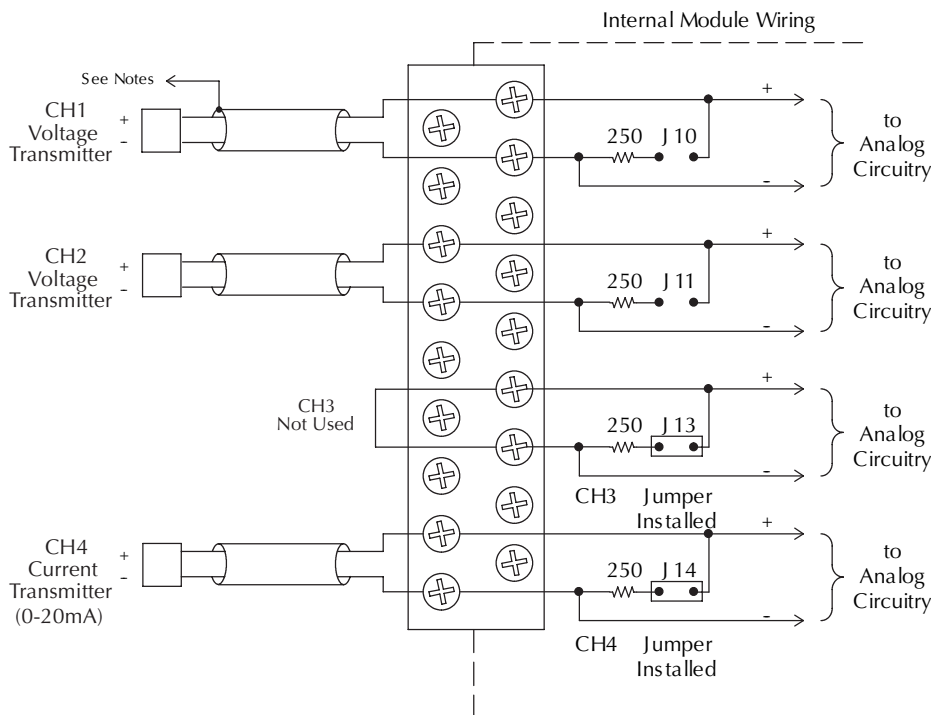

Analog Input Modules

F3-08AD-1 8-Channel Analog Input \$412.00 (Replaces F3-08AD)	
Number of Channels	8, single ended (one common)
Input Ranges	4-20mA
Resolution	12 bit (1 in 4096)
Low Pass Filter	-3db @ 200Hz (-6db/octave)
Input Impedance	250ohm ± 0.1%, 1/2W current input
Absolute Maximum Ratings	±40mA
Conversion Time	1 channel per CPU scan
Converter Type	Successive approximation, MAX170
Linearity Error	± 1 count (0.03% of full scale) maximum
Input Stability	±0.05 count
Maximum Inaccuracy	0.1% of full scale at 77°F (25°C)
Accuracy vs. Temperature	57ppm/°C maximum full scale (including maximum offset change of 2 counts)

Recommended Fuse	0.032A, Series 217 fast-acting
Power Budget Requirement	45mA @9 VDC, 55mA @ 24VDC
External Power Supply	None required
Operating Temperature	32° to 140°F (0° to 60°C)
Storage Temperature	-4° to 158°F (-20° to 70°C)
Relative Humidity	5 to 95% (non-condensing)
Environmental air	No corrosive gases permitted
Vibration	MIL STD 810C 514.2
Shock	MIL STD 810C 516.2
Noise Immunity	NEMA ICS3-304

See page D3-29 for part numbers of ZIPLink cables and connection modules compatible with this I/O module.



- Note 1:** Terminate all shields at their respective signal source.
- Note 2:** To avoid "ground loop" errors, the following transmitter types are recommended:
 2 and 3 wire: Isolation between input signal and P/S
 4 wire: Full isolation between input signal, P/S and output signal.
- Note 3:** A Series 217 0.032A fast-acting fuse is recommended for 4-20mA applications.

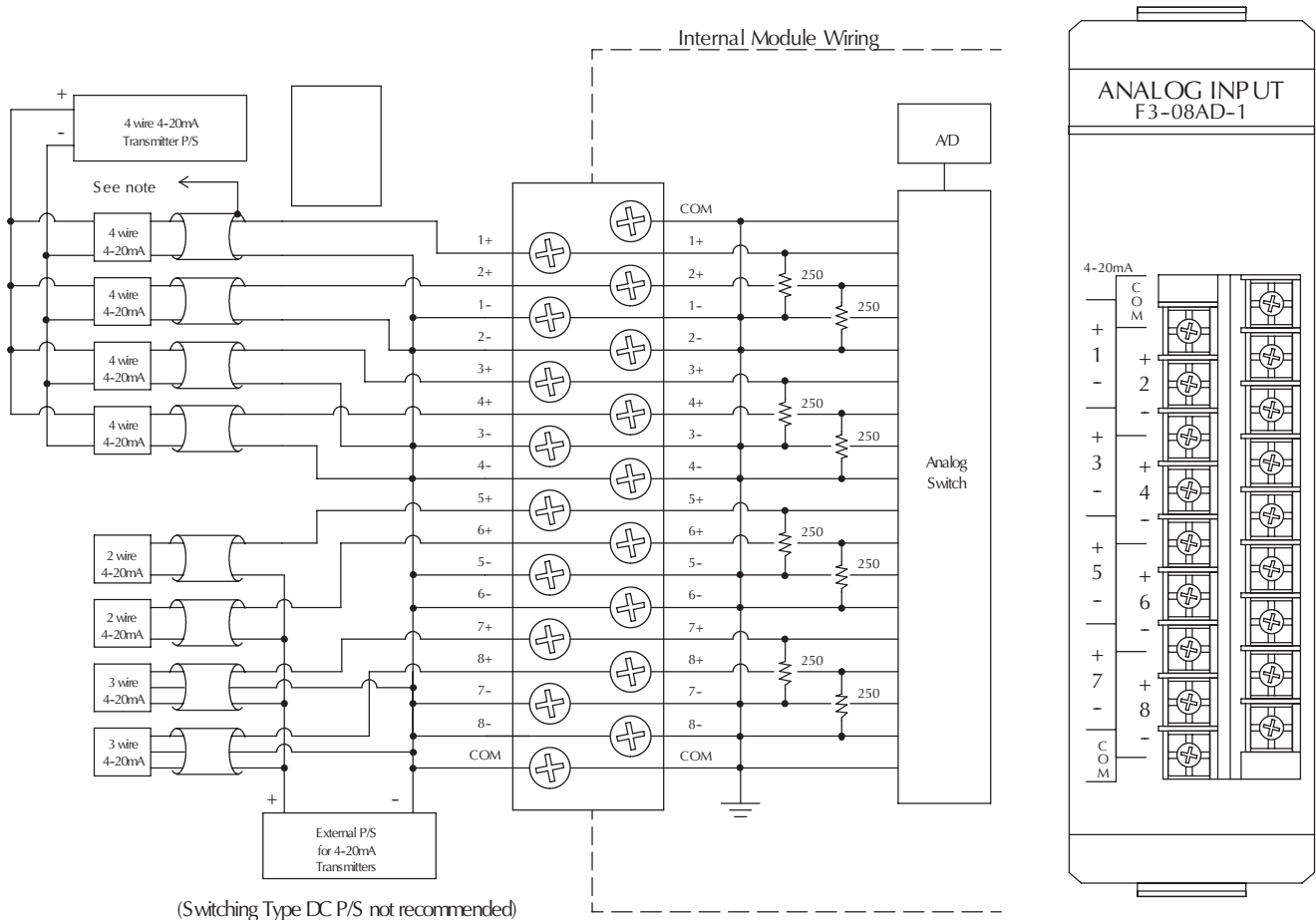

Analog Input Modules

F3-16AD 16-Channel Analog Input \$530.00	
Number of Channels	16, single ended (one common)
Input Ranges	$\pm 5V$, $\pm 10V$, $0-5V^1$, $0-10V$, $0-20mA$, $4-20mA^2$
Channels Individually Configured	Range is selected for all channels. Each channel can be wired for voltage or current.
Resolution	12 bit (1 in 4096)
Input Impedance	2Mohm, voltage input, 500ohm $\pm 1\%$ current input
Absolute Maximum Ratings	$\pm 25mA$, voltage input $\pm 30mA$, current input
Conversion Time	35 μs per channel, 1 channel per CPU scan
Converter Type	Successive Approximation, AD574
Linearity Error	± 1 count maximum
Maximum Inaccuracy at 77°F (25°C)	0.25% of full scale, voltage input 1.25% of full scale, current input
Accuracy vs. Temperature	57ppm/°C maximum full scale

Recommended Fuse	0.032 A, Series 217 fast-acting, current inputs
Power Budget Requirement	55mA @ 9VDC, 65mA @ 24VDC
External Power Supply	None required
Operating Temperature	32° to 140°F (0° to 60 C)
Storage Temperature	-4° to 158°F (-20° to 70°C)
Relative Humidity	5 to 95% (non-condensing)
Environmental Air	No corrosive gases permitted
Vibration	MIL STD 810C 514.2
Shock	MIL STD 810C 516.2
Noise Immunity	NEMA ICS3-304

See page D3-29 for part numbers of ZIPLink cables and connection modules compatible with this I/O module.



- requires gain adjustment with potentiometer.
- resolution is 3275 counts (instead of 4096). Allows easier broken transmitter detection.

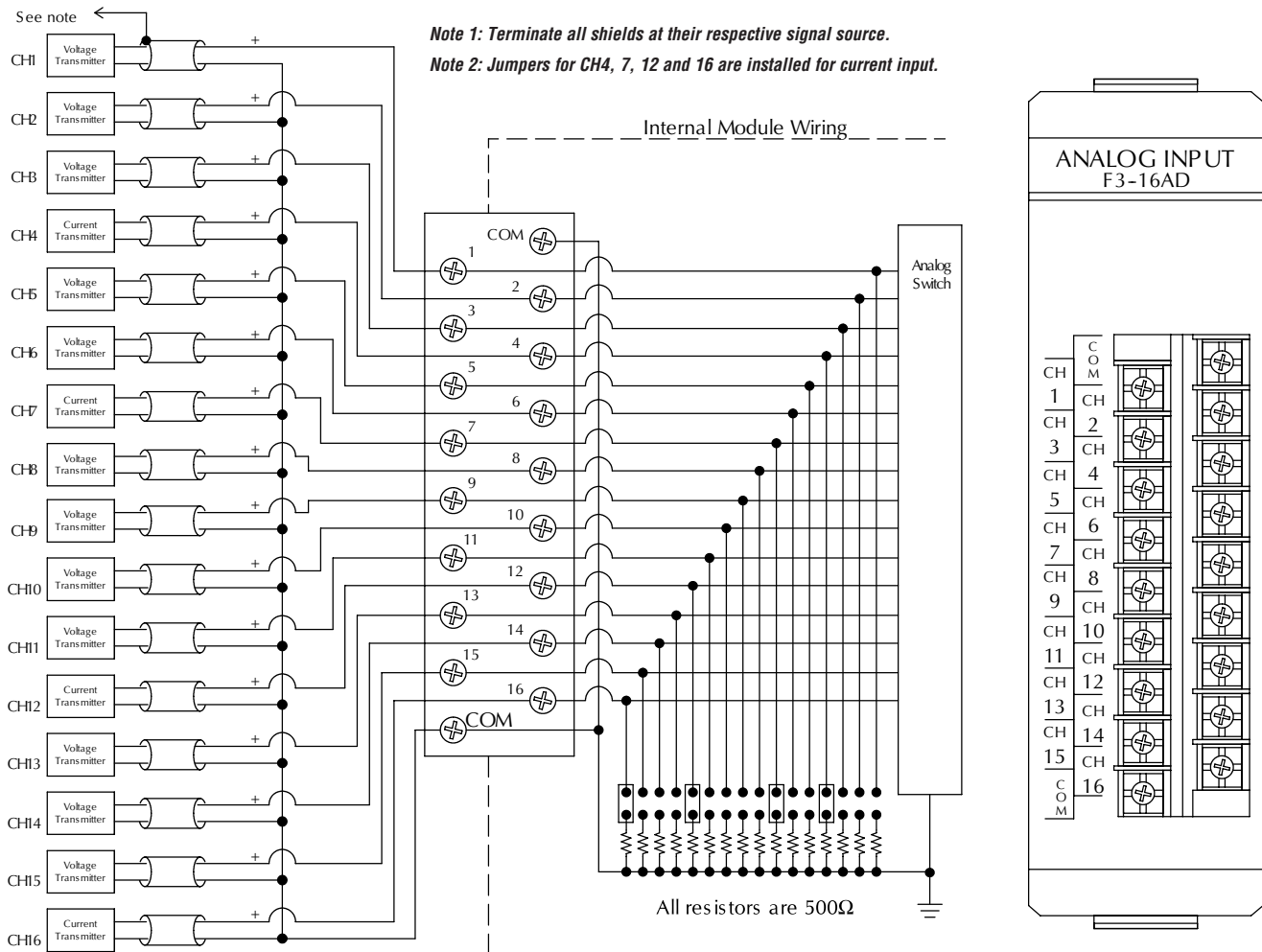

Temperature Input Modules

F3-08THM-n 8-Channel Thermocouple Input \$589.00	
Note: When you order the module, replace the "n" with the type of thermocouple needed. For example, to order a Type J thermocouple module, order part number F3-08THM-J or F3-08THM-K for type K. Types J and K are stock. All others are special order.	
Input Ranges	Type E: -270/1000°C, -450/1832°F (obsolete) Type J: -210/760°C, -350/1390°F Type K: -270/1370°C, -450/2500°F Type R: 0/1768°C, 32/3214°F (obsolete) Type S: 0/1768°C, 32/3214°F (obsolete) Type T: -270/400°C, -450/752°F (obsolete) -1: 0-50mV -2: 0-100mV
Resolution	12 bit (1 in 4096)
Input Impedance	27Kohm DC
Absolute Maximum Ratings	Fault protected input, 130 Vrms or 100 VDC
Cold Junction Compensation	Automatic
Conversion Time	15ms per channel, minimum 1 channel per CPU scan

Converter Type	Successive approximation, AD574
Linearity Error	±1 count (0.03% of full scale) maximum
Maximum Inaccuracy at 77°F (25°C)	0.35% of full scale
Accuracy vs. Temperature	57ppm/°C maximum full scale
Power Budget Requirement	50mA @ 9VDC, 34mA @ 24VDC
External Power Supply	None required
Operating Temperature	32° to 140°F (0° to 60°C)
Storage Temperature	-4° to 158°F (-20° to 70°C)
Relative Humidity	5 to 95% (non-condensing)
Environmental Air	No corrosive gases permitted
Vibration	MIL STD 810C 514.2
Shock	MIL STD 810C 516.2
Noise Immunity	NEMA ICS3-304

Notes:

1. Terminate shields at the respective signal source.
2. Leave unused channel open (no connection).
3. This module is not compatible with the ZIPLink wiring system.

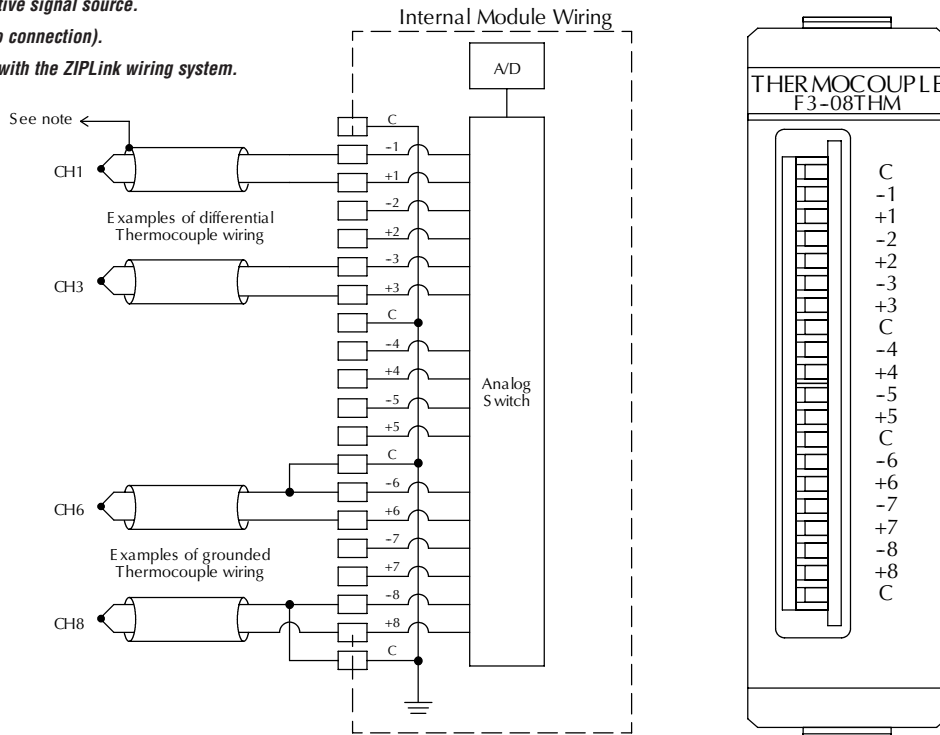

Analog Output Modules

F3-04DA-1 4-Channel Analog Output \$449.00	
Number of Channels	4
Output Range	0 - 5V, 0-10V 4-12 mA, 4-20 mA (source)
Channels Individually Configured	Yes
Resolution	12-bit (1 in 4096)
Output Type	Single ended (one common)
Output Impedance	0.5ohm typical, voltage output
Output Current	5mA source, 2.5mA sink (voltage)
Short-circuit Current	40mA typical, voltage output
Load Impedance	1Kohm maximum, current output 2Kohm minimum, voltage output
Linearity Error	±1 count (±0.03% maximum)
Maximum Inaccuracy at 77° F (25° C)	± 0.6% of span, current output ± 0.2% of span, voltage output

Accuracy vs. Temperature	±50ppm/°C maximum
Conversion Time	30µS maximum
Power Budget Requirement	144mA @ 9V, 108mA @24V
External Power Supply	None required
Operating Temperature	32° to 140°F (0° to 60°C)
Storage Temperature	-4° to 158°F (-20° to 70°C)
Relative Humidity	5 to 95% (non-condensing)
Environmental Air	No corrosive gases permitted
Vibration	MIL STD 810C 514.2
Shock	MIL STD 810C 516.2
Noise Immunity	NEMA ICS3-304

See page D3-29 for part numbers of ZIPLink cables and connection modules compatible with this I/O module.



Note 1: Shields should be connected to the 0V (COM) of the module.

Note 2: Unused voltage and current outputs should remain open (no connections).

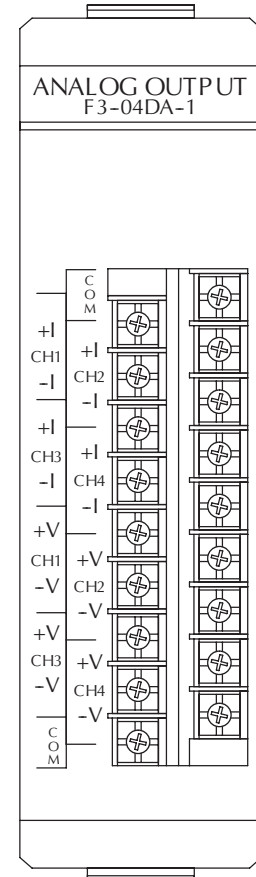
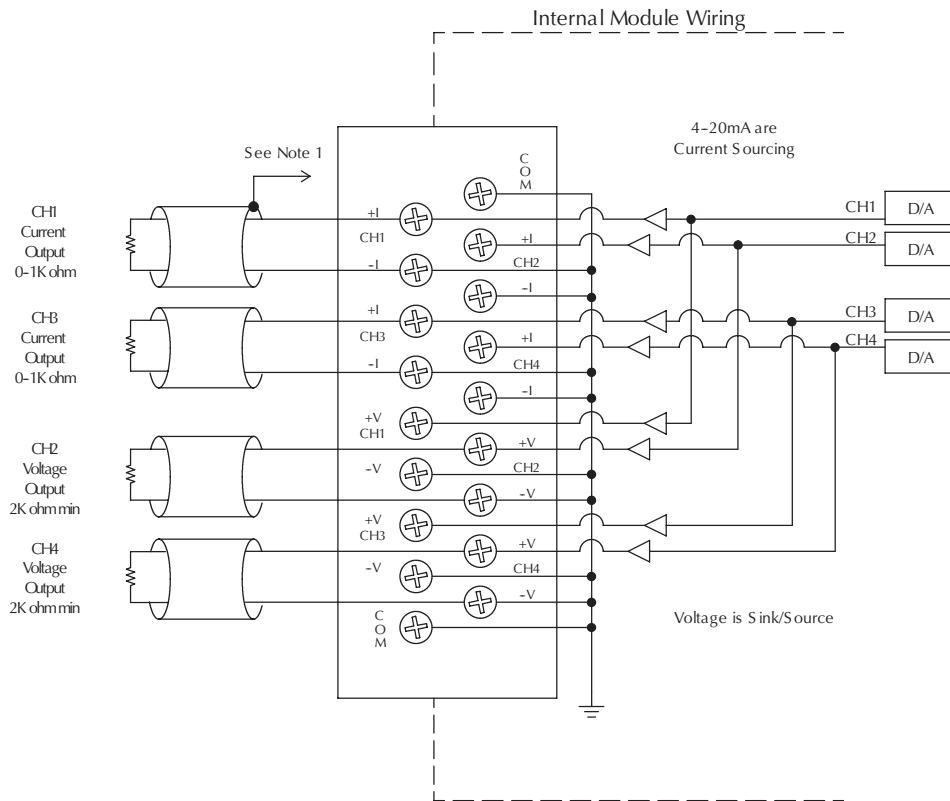

Analog Output Modules

F3-04DAS 4-Channel Isolated Analog Output \$625.00	
Number of Channels	4
Output Ranges	±5V, ±10V, 0 - 5V, 0 - 10V, 1 - 5V 0-20mA, 4-20mA
Channels Individually Configurable	Yes
Resolution	12-bit (1 in 4096)
Output Type	Isolated, 750 VDC channel-to-channel 750 VDC channel-to-logic
Output Current	±5mA voltage output
Short-circuit Current	±20mA typical, voltage output
Capacitive Load Drive	0.1µF typical, voltage output
Load Impedance	470ohm maximum, current output 2Kohm minimum, voltage output
Isolation Mode Rejection	140dB at 60Hz
Linearity Error	±1 count (±0.03% maximum)
Calibration Error	±0.15% typical, ±0.75% max. of span ±10 ppm/°C maximum of full scale

Calibrated Offset Error	±1 count maximum, current output ±5 mV typical, ±50mV max., voltage out ±0.2mV typical /°C
Conversion Time	30µS maximum, 1 channel/scan
Power Budget Requirement	154mA @ 9V, 145mA @ 24V
External Power Supply	None required
Operating Temperature	32° to 140°F (0° to 60°C)
Storage Temperature	-4° to 158°F (-20° to 70°C)
Relative Humidity	5 to 95% (non-condensing)
Environmental Air	No corrosive gases permitted
Vibration	MIL STD 810C 514.2
Shock	MIL STD 810C 516.2
Noise Immunity	NEMA ICS3-304

See page D3-29 for part numbers of ZIPLink cables and connection modules compatible with this I/O module.



- Note 1:** Shields should be connected to the respective channel's -V terminal of the module.
- Note 2:** Each isolated output channel may have either a voltage or current load, but not both.
- Note 3:** An external 0.31 Amp fast-acting fuse in series with the isolated +I terminal (+15VDC) is recommended to protect against accidental shorts to the -V terminal (15VDC common).
- Note 4:** Do not attempt to source more than 20mA from any one of the four isolated 15VDC power supplies.

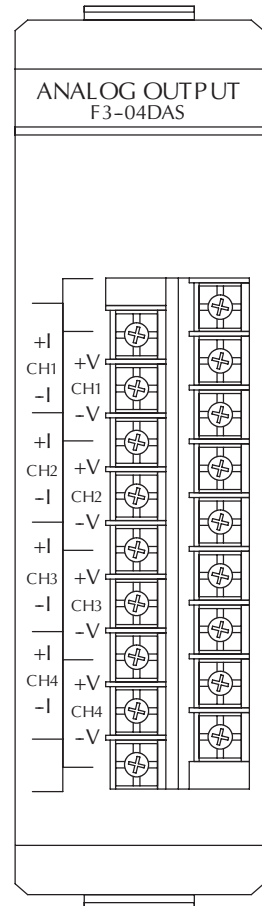
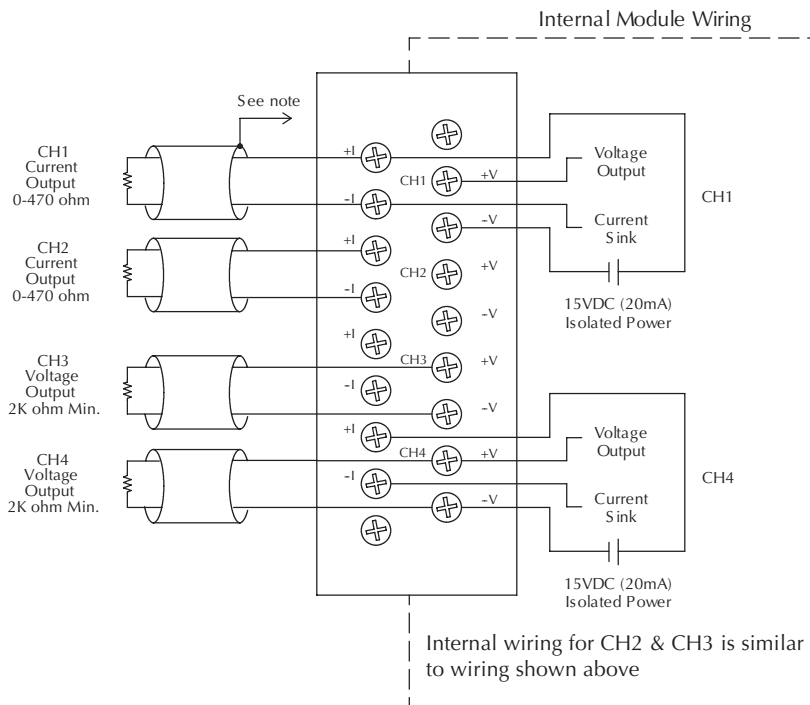

DL305 Instruction Set

Boolean Instructions

- Store (STR)**
Begins a new rung or an additional branch in a rung with a normally open contact.
- Store Not (STRN)**
Begins a new rung or an additional branch in a rung with a normally closed contact.
- Store timer (STR TMR) D3-330/340 only**
Begins a new rung or additional branch in a rung with a normally open timer contact.
- Store not timer (STR NOT TMR) D3-330/340 only**
Begins a new rung or additional branch in a rung with a normally closed timer contact.
- Store counter (STR CNT) D3-330/340 only**
Begins a new rung or additional branch in a rung with a normally open counter contact.
- Store not counter (STR NOT CNT) DL330/DL340 only**
Begins a new rung or additional branch in a rung with a normally closed counter contact.
- Or (OR)**
Logically Ors a normally open contact in parallel with another contact in a rung.
- Or not (OR NOT)**
Logically Ors a normally closed contact in parallel with another contact in a rung.
- Or timer (OR TMR) D3-330/340 only**
Logically Ors a normally open timer contact in parallel with another contact in a rung.
- Or not timer (OR NOT TMR) D3- 330/340 only**
Logically Ors a normally closed timer contact in parallel with another contact in a rung.
- Or counter (OR CNT) D3-330/340 only**
Logically Ors a normally open counter contact in parallel with another contact in a rung.
- Or not counter (OR NOT CNT) D3-330/340 only**
Logically Ors a normally closed counter contact in parallel with another contact in a rung.
- And (AND)**
Logically ANDs a normally open contact in series with another contact in a rung.
- And not (ANDN)**
Logically ANDs a normally closed contact in series with another contact in a rung.
- And timer (AND TMR) D3-330/340 only**
Logically ANDs a normally open timer contact in series with another contact in a rung.
- And not timer (AND NOT TMR) D3-330/340 only**
Logically ANDs a normally closed timer in series with another contact in a rung.
- And counter (AND CNT) D3-330/340 only**
Logically ANDs a normally open counter contact in series with another contact in a rung.
- And not counter (And NOT CNT) D3-330/340 only**
Logically ANDs a normally closed counter contact in series with another contact in a rung.
- And store (AND STR)**
Logically ANDs two branches in a rung in series.
- Or store (OR STR)**
Logically Ors two branches of a rung in parallel.
- Out (OUT)**
Reflects the status of the rung (ON/OFF) and outputs the discrete (ON/OFF) state to the specified image register.
- Set (SET) D3-330/340 only**
Sets or turns on an output. Once the output is set it will remain on until it is reset using the RST instruction or by a result of the ladder logic execution.
- Reset (RST)**
Resets or turns OFF an output or resets a counter.
- Set out (SET OUT)**
Reflects the status of the rung (ON/OFF) and outputs the discrete (ON/OFF) state to the specified image register.
- Set out reset (SET OUT RST)**
Typically known as a one shot, when the input logic produces an OFF to ON transition the output will turn ON for one CPU scan.
- Master control set (MCS)/Master control reset (MCR)**
The Master control set and Master Control Reset instructions are used to provide an additional left power rail which is controllable by an input contact. This is sometimes known as a sub power rail. Any number of rungs of ladder logic can be disabled using these instructions.

Comparative Boolean Instructions

- Store, if equal (STRE) D3-330/340 only**
Begins a new rung or additional branch in a rung with a normally open comparative counter contact. The contact will be ON if C aaa = B bbbb.
- Store not, if equal (STR N) D3-330/340 only**
Begins a new rung or additional branch in a rung with a normally closed comparative counter contact. The contact will be ON if C aaa = B bbbb.
- Or, if equal (ORE) D3-330/340 only**
Connects a normally open comparative counter contact in parallel with another contact. The contact will be ON if C aaa = B bbbb.
- Or not, if equal (OR N) D3-330/340 only**
Connects a normally closed comparative counter contact in parallel with another contact. The contact will be ON if C aaa = B bbbb.
- And, if equal (ANDE) D3-330/340 only**
Connects a normally open comparative counter contact in series with another contact. The contact will be ON if C aaa = B bbbb.
- And not, if equal (ANDNE) D3-330/340 only**
Connects a normally closed comparative counter contact in series with another contact. The contact will be ON if C aaa = B bbbb.

Accumulator Load and Output Instructions

- Data store (F50)**
Loads the value of a 16-bit-register, two consecutive 8-bit registers, or a 4-digit BCD value into the accumulator.
- Data store 1 (F51)**
Loads the value from a specified 8-bit register into the lower 8 bits of the accumulator.
- Data store 2 (F52)**
Loads the value of the most significant 4 bits of a specified 8 bit register into the least significant 4 bits of the accumulator.
- Data store 3 (F53)**
Loads the value of the least significant 4 bits of a specified 8 bit register into the least significant 4 bits of the accumulator.
- Data store 5 (F55)**
Loads the value of 16-image register locations for a specified 16-point input module into the accumulator.
- Data out (F60)**
Copies the 16-bit value in the accumulator to a 16-bit reference or two consecutive 8-bit registers.
- Data out 1 (F61)**
Copies the value in the lower 8 bits of the accumulator to a specified 8-bit register.
- Data out 2 (F62)**
Copies the value in the least significant 4 bits of the accumulator into the most significant 4 bits of a specified 8-bit register.
- Data out 3 (F63)**
Copies the value in the least significant 4 bits of the accumulator to the least significant 4 bits of a specified 8-bit register.
- Data out 5 (F65)**
Copies the 16-bit value in the accumulator to the image register of a specified 16 point output module.

Bit Operation Instructions

- Shift left (F80)**
Shifts the value in the accumulator a specified number of bits (15 maximum) to the left.
- Shift right (F81)**
Shifts the value in the accumulator a specified number of bits (15 maximum) to the right.
- Decode (F82)**
Decodes a 4-bit binary number in the accumulator by setting the appropriate bit position to a one.
- Encode (F83)**
Encodes the accumulator bit position that contains a 1 by returning the appropriate 4-bit binary representation.
- Binary (F85)**
Converts a BCD value in the accumulator to the binary/HEX equivalent value.
- Binary coded decimal (F86)**
Converts a binary/HEX equivalent value in the accumulator to the BCD equivalent.
- Inverse (F84)**
Generates the one's complement of the number in the accumulator.

Accumulator Logic Instructions

- Data and (F75)**
Logically ANDs the value in a 16-bit reference, two consecutive 8-bit registers, or a 4-digit BCD constant with the value in the accumulator.
- Data or (F76)**
Logically ORs the value in a 16-bit reference, two consecutive 8-bit registers, or 4-digit BCD constant with the value in the accumulator.
- Compare (F70)**
Compares the value in a 16-bit reference, two consecutive 8-bit registers, or 4-digit BCD constant with the value in the accumulator.

Timer, Counter and Shift Register Instructions

- Timer (TMR) D3-330/340 only**
Provides a single input timer with a 0.1 second increment (0-999.9 seconds) in the normal operating mode, or a 0.01 second increment (0-99.99 seconds) in the fast timer mode.
- Counter (CNT) D3-330/340 only**
Provides a counter with a count and reset input and a range of 0-9999.
- Shift register (SR) D3-330/340 only**
Shifts data through a predefined number of shift register bits (up to 128 bits).

Math Instructions

- Add (F71)**
Adds the value of a 16-bit reference, two consecutive 8 bit registers, or a 4-digit BCD constant with the value in the accumulator.
- Subtract (F72)**
Subtracts the value in a 16-bit register, two consecutive 8-bit registers, or a 4-digit BCD constant from the value in the accumulator.
- Multiply (F73)**
Multiplies the value in a 16-bit register, two consecutive 8-bit registers, or a 4-digit BCD constant by the value in the accumulator.
- Divide (F74)**
Divides the value in the accumulator by the value in a 16-bit register, two consecutive 8-bit registers, or a 4-digit BCD constant.

Message Instructions

- Fault (F20)**
Used to display a 4-digit BCD constant, 16-bit register, or two consecutive 8-bit data registers on the handheld programmer or DirectSoft.

