

AUTOMATIONDIRECT.com

DURA IIIIII PULSE

AC and DC Drives



IRONHORSE®



BOOKMARKS

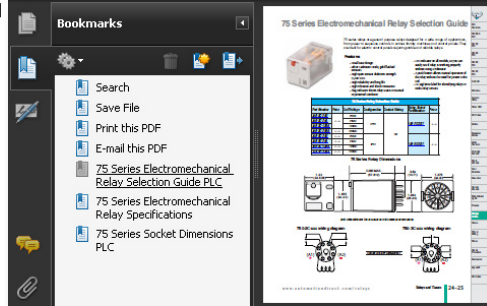

In this interactive PDF you can:

- Use bookmarks to navigate by product category
- Use bookmarks to save, search, print or e-mail the catalog section
- Click on part #s to link directly to our online store for current pricing, specs, stocking information and more

Up-to-date price list:
www.automationdirect.com/pricelist

FREE Technical Support:
www.automationdirect.com/support

FREE Videos:
www.automationdirect.com/videos

FREE Documentation:
www.automationdirect.com/documentation

FREE CAD drawings:
www.automationdirect.com/cad



Company Information

Drives

Soft Starters

Motors

Power Transmission

Motion: Servos and Steppers

Motor Controls

Sensors: Proximity

Sensors: Photoelectric

Sensors: Encoders

Sensors: Limit Switches

Sensors: Current

Sensors: Pressure

Sensors: Temperature

Sensors: Level

Sensors: Flow

Pushbuttons and Lights

Stacklights

Signal Devices

Process

Relays and Timers

Pneumatics: Air Prep

Pneumatics: Directional Control Valves

Pneumatics: Cylinders

Pneumatics: Tubing

Pneumatics: Air Fittings

Appendix Book 2

Terms and Conditions

#1 Value in AC Drives

from **AUTOMATIONDIRECT**.com

DURA PULSE



GS1 AC minidrive

- 1/4 and 1/2 hp, 115 VAC (single-phase input)
- 1/4, 1/2 and 1 hp, 230 VAC (single/three-phase input)
- 2 hp, 230 VAC
 - Simple Volts/Hertz control
 - 130% starting torque at 5 Hz
 - Electronic overload protection
 - Use of integrated potentiometer or keypad for local speed setting
 - External analog input (0-10V, 0-20 mA or 4-20 mA)
 - Three preset speeds
 - Four programmable digital inputs
 - One programmable relay output
 - RS485 Modbus communications up to 19.2K
 - Optional Ethernet communications DIN-rail mountable
 - Two-year replacement warranty
 - UL, cUL, CE listed

GS2 AC microdrive

- 1/4 hp to 1 hp, 115 VAC (single-phase input)
- 1/2 hp to 3 hp, 230 VAC (single/three-phase input)
- 5 hp to 7.5 hp, 230 VAC
- 1 to 10 hp, 460 VAC
- 1 to 10 hp, 575 VAC
 - Simple Volts/Hertz control
 - 150% starting torque
 - Dynamic braking circuit
 - Electronic overload protection
 - Use of integrated potentiometer or keypad for local speed setting
 - External analog input (0-10V, 0-20 mA or 4-20 mA)
 - Removable keypad
 - Seven preset speeds
 - Six programmable digital inputs
 - Two programmable relay outputs
 - PID control
 - RS-232/RS-485 Modbus communications up to 38.4K
 - Optional Ethernet communications
 - Two-year replacement warranty
 - UL, cUL
 - CE Listed (except 575V model)

DURAPULSE GS3 AC sensorless vector drives

- 1 hp to 3 hp, 230VAC (single/three-phase input)
- 5 hp to 50 hp, 230VAC
- 1 hp to 100 hp, 460 VAC

The *DURAPULSE* series is a line of auto-tuning and sensorless vector control AC drives. All parameters are programmable via a removable keypad that will store up to four different application programs.

- V/Hz or sensorless vector control modes
- 150% starting torque
- Removable keypad
- Three analog inputs - (0-10V, -10 to +10 VDC or 4-20 mA/0 - 20 mA)
- 16 preset speeds
- 11 programmable digital inputs
- Four programmable outputs
- Optional encoder feedback card
- RS-485 Modbus communications up to 38.4K
- Optional Ethernet communications
- Two-year replacement warranty
- UL, CE listed

Note: All AC drives have three-phase inputs and three-phase outputs, unless otherwise specified.



GSoft Configuration software is now available via download for free (CD is available for \$9.00).
www.automationdirect.com/pn/gsoft

LR Series Line Reactors

- Universal mounting feet with multiple mounting slots; can replace most reactors using existing mounting holes
- 10-year warranty
- cUL_{US} listed (E197592)
- CE marked
- RoHS

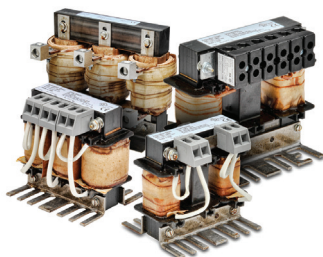

GS Drive Accessories

- Drive Fuses and Fuse Kits
 - Class T fuse kits
 - High Speed Class J fuses and fuse holders
- Dynamic braking resistors and DBUs
- EMI and RFI filters
- Replacement cooling fans

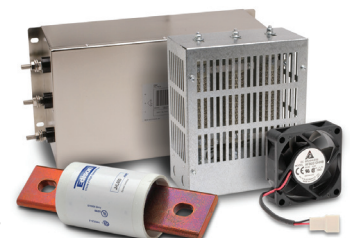

Why choose an AC drive?

AC Drives are often the best choice:

- **Save energy** - Significant energy savings can be realized in many fan and pump applications that previously used dampers or ON/OFF control: AC drives allow motor speed to be fine-tuned to the process.
- **Reduce start up current** - controlling the inrush current at motor start-up allows the use of smaller fuses, and reduces electrical peak load.
- **Reduce mechanical stress** - controlled/smooth starting and stopping minimize mechanical shock and wear and tear on the system.
- **Power Factor** - Motors have very poor power factors (especially at light loading). Drives significantly increase power factor (even at light loading) and can eliminate the need for power factor correction capacitors and/or utility power factor charges.
- **Variable Speed and integrated functionality** - AC drives can vary motor speed and direction by operator input (keypad buttons/speed control knob) or by digital and analog inputs (from pushbuttons/switches/pots or PLC outputs). Basic machine control can sometimes be performed in the drive (limit switches/sensors can be wired to the drive's inputs to control motor speed or direction).

Choose the AC drive you need below

AC Drive Family		Voltage Phase	HP	Part #
GS1	Simple, basic AC drive. Built-in Modbus communications. Integrated keypad with speed control knob. 1/4 to 2 HP	120V 1PH	0.25	GS1-10P2
			0.5	GS1-10P5
		230 1PH or 3PH	0.25	GS1-20P2
			0.5	GS1-20P5
		230V 3PH	1	GS1-21P0
		2	GS1-22P0	
GS2	General Purpose AC drive with built-in Modbus communications and PID control. Detachable keypad with speed control knob and Forward/Reverse keypad control. 1/4 to 10 HP	120V 1PH	0.25	GS2-10P2
			0.5	GS2-10P5
			1	GS2-11P0
		230V 1PH or 3PH	0.5	GS2-20P5
			1	GS2-21P0
			2	GS2-22P0
			3	GS2-23P0
		230V 3PH	5	GS2-25P0
			7.5	GS2-27P5
		460V 3PH	1	GS2-41P0
			2	GS2-42P0
			3	GS2-43P0
			5	GS2-45P0
			7.5	GS2-47P5
		575V 3PH	10	GS2-4010
			1	GS2-51P0
			2	GS2-52P0
			3	GS2-53P0
			5	GS2-55P0
				7.5
		10	GS2-5010	
DURAPULSE - GS3	Sensorless Vector AC Drive with many advanced features: Modbus communications, PID control, motor autotune, optional encoder feedback card, DC injection braking, multiple analog speed inputs (trim). Detachable keypad with Forward/Reverse control can store/transfer up to 4 separate drive configurations. 1 to 100 HP	230V 1PH or 3PH	1	GS3-21P0
			2	GS3-22P0
			3	GS3-23P0
		230V 3PH	5	GS3-25P0
			7.5	GS3-27P5
			10	GS3-2010
			15	GS3-2015
			20	GS3-2020
			25	GS3-2025
			30	GS3-2030
			40	GS3-2040
			50	GS3-2050
			1	GS3-41P0
			2	GS3-42P0
			3	GS3-43P0
			5	GS3-45P0
			7.5	GS3-47P5
		10	GS3-4010	
		460V 3PH	15	GS3-4015
			20	GS3-4020
25	GS3-4025			
30	GS3-4030			
40	GS3-4040			
50	GS3-4050			
		60	GS3-4060	
		75	GS3-4075	
		100	GS3-4100	

GS1 and GS2 Series AC Drives



GS1 Drives	AutomationDirect GS1	VS.	Allen-Bradley Powerflex 4M™
0.25 hp	\$99.00 GS1-10P2		\$307.00 22F-V1P6N103
2 hp	\$164.00 GS1-22P0		\$391.00 22F-B8P0N103

All prices are U.S. published prices. AutomationDirect prices as of 4/18/16. Allen-Bradley prices taken from www.wemerelectric.com 5/25/2015. Prices subject to change without notice.

Simple communications
Each drive has a built-in Modbus RTU RS-485 communications port (RS-232/485 configurable on the GS2 series). An optional Ethernet communications module is a snap to integrate on a network with our PLCs and operator interfaces.

GS1 AC minidrives

- ¼ and ½ hp, 115 VAC (single-phase input)
- ¼, ½ and 1 hp, 230 VAC (single/three-phase input)
- 2 hp, 230 VAC (three-phase input)

Features

- Simple Volts/Hertz control
- Pulse Width Modulation(PWM)
- 3 - 10 kHz carrier frequency
- IGBT technology
- 130% starting torque at 5 Hz
- 130% rated current for 1 minute
- Electronic overload protection and stall prevention
- Adjustable accel and decel ramps
- S-curve settings for acceleration and deceleration
- Automatic torque and slip compensation
- DC braking
- Three skip frequencies
- Trip history
- Integral keypad and speed potentiometer
- Programmable jog speed
- Three programmable preset speeds
- Four programmable digital inputs, one programmable relay output
- Programmable analog input
- RS-485 Modbus communications up to 19.2K
- Optional Ethernet communications
- UL/CUL listed; CE

High quality
The GS series is manufactured exclusively for **AutomationDirect** with reliable IGBT technology. We started with a proven design and made it even better and easier to use.

Simple programming
The GS series can be programmed by the average technician. Default values were carefully selected so the drives run "out of the box" for most applications. Parameters are intelligently grouped into menu structures that make sense.



GS1 Mini AC Inverters

Part Number	Input Voltage	Output Voltage	hp	Output Amps	Price (US\$)
GS1-10P2	115V, 1ph	230V, 3ph	0.25	1.6 A	\$99.00
GS1-10P5	115V, 1ph	230V, 3ph	0.5	2.5 A	\$117.00
GS1-20P2	230V, 1ph/3ph	230V, 3ph	0.25	1.6 A	\$113.00
GS1-20P5	230V, 1ph/3ph	230V, 3ph	0.5	2.5 A	\$117.00
GS1-21P0	230V, 1ph/3ph	230V, 3ph	1.0	4.2 A	\$134.00
GS1-22P0	230V, 3ph	230V, 3ph	2.0	7.0 A	\$164.00

GS2 Micro AC Inverters

Part Number	Input Voltage	Output Voltage	hp	Output Amps	Price (US\$)
GS2-10P2	115V, 1ph/3ph	230V, 3ph	0.25	1.6	\$156.00
GS2-10P5	115V, 1ph/3ph	230V, 3ph	0.5	2.5	\$166.00
GS2-11P0	115V, 1ph/3ph	230V, 3ph	1.0	4.2	\$186.00
GS2-20P5	230V, 1ph/3ph	230V, 3ph	0.5	2.5	\$158.00
GS2-21P0	230V, 1ph/3ph	230V, 3ph	1.0	5.0	\$177.00
GS2-22P0	230V, 1ph/3ph	230V, 3ph	2.0	7.0	\$251.00
GS2-23P0	230V, 1ph/3ph	230V, 3ph	3.0	10.0	\$309.00
GS2-25P0	230V, 3ph	230V, 3ph	5.0	17.0	\$363.00
GS2-27P5	230V, 3ph	230V, 3ph	7.5	25.0	\$465.00
GS2-41P0	460V, 3ph	460V, 3ph	1.0	3.0	\$261.00
GS2-42P0	460V, 3ph	460V, 3ph	2.0	4.0	\$303.00
GS2-43P0	460V, 3ph	460V, 3ph	3.0	5.0	\$357.00
GS2-45P0	460V, 3ph	460V, 3ph	5.0	8.2	\$410.00
GS2-47P5	460V, 3ph	460V, 3ph	7.5	13.0	\$586.00
GS2-4010	460V, 3ph	460V, 3ph	10	18.0	\$725.00
GS2-51P0	575V, 3ph	575V, 3ph	1	1.7	\$279.00
GS2-52P0	575V, 3ph	575V, 3ph	2	3.0	\$319.00
GS2-53P0	575V, 3ph	575V, 3ph	3	4.2	\$378.00
GS2-55P0	575V, 3ph	575V, 3ph	5	6.6	\$491.00
GS2-57P5	575V, 3ph	575V, 3ph	7.5	9.9	\$721.00
GS2-5010	575V, 3ph	575V, 3ph	10	12.2	\$812.00

Simple to Install, Simple to Configure



Removable keypad (GS2)

The removable keypad includes an LED display for parameters and data, programming keys and a potentiometer for direct setpoint adjustment. The keypad can be remotely mounted (with optional keypad cable).

Two-year warranty

The standard two-year warranty for the GS series is the best in the industry.

GS2 AC microdrives

- ¼ hp to 1 hp, 115 VAC (single-phase input)
- ½ hp to 3 hp, 230 VAC (single/three-phase input)
- 5 hp to 7.5 hp, 230 VAC (three-phase input)
- 1 to 10 hp, 460 VAC (three-phase input)
- 1 to 10 hp, 575 VAC (three-phase input)

Features

- All GS1 features, plus:
- 1-12 kHz carrier frequency
 - 150% starting torque
 - Dynamic braking circuit
 - Seven programmable preset speeds
 - Integral PID control
 - Removable keypad with potentiometer
 - Programmable analog input and output
 - Six programmable digital inputs, two programmable relay outputs
 - RS-232/485 Modbus communications up to 38.4K
 - UL/CUL listed
 - CE Listed (except 575V model)

AC Drives	AutomationDirect GS2 or GS3 Series	VS.	Allen-Bradley Powerflex Series
2 hp <i>230V</i>	\$251.00 GS2-22P0		\$501.00 22A-B8P0N104
5 hp	\$363.00 GS2-25P0		\$693.00 22A-B017N104
5 hp <i>460V</i>	\$410.00 GS2-45P0		\$893.00 22A-D8P7N104
10 hp	\$734.00 GS3-4010 (Durapulse)		\$1,750.00 22B-D017N104

All prices are U.S. published prices. AutomationDirect prices as of April 2016. Allen-Bradley prices taken from www.wemerelectric.com 3/25/2015. Prices subject to change without notice.

DURAPULSE® AC Drives

DURAPULSE builds on the GS series

The *DURAPULSE* series builds on the simplicity and flexibility of the GS1 and GS2 series, incorporating feedback from our customers and extensive research and testing in our own drives lab. While the GS1 offers simple Volts per Hertz control, and the GS2 adds PID functionality and dynamic braking, *DURAPULSE* offers sensorless vector control and autotuning, as well as optional encoder feedback for enhanced speed control. *DURAPULSE* configuration settings are a superset of the GS series, so programming for the same parameters is identical across all series.

- 1 hp to 3 hp, 230VAC (single/three-phase input)
- 5 hp to 50 hp, 230VAC (three-phase input)
- 1 hp to 100 hp, 460 VAC (three-phase input)

DURA IIIIIPULSE®

Visit: www.durapulse.com

Durability guaranteed

DURAPULSE drives are backed by the same 2-year warranty as the GS series!

Features

- Simple Volts/Hertz control
- Sensorless vector control with autotune
- Sensorless vector control with optional encoder feedback card, for tighter speed control
- Variable carrier frequency, depending on model
- IGBT technology
- 150% starting torque
- 150% rated current for one minute
- Internal dynamic braking circuit for models under 20 hp
- Automatic torque and slip compensation
- Programmable jog speed
- Removable smart keypad with parameter upload/download
- Easy-to-understand parameter text labels
- HIM keypad with memory to store up to four programs of any DURApulse drive
- Three analog inputs and one analog output
- Eleven digital inputs
- Four programmable outputs: Three digital and one relay
- One digital frequency pulse output
- RS-485 Modbus communications
- Ethernet communication optional
- UL/CE listed
- Optional software package with full programmability, trending and application setup

Little programming required

Default values were carefully selected so the drives run “out of the box” for most applications, with default values set for the U.S. industrial market. Keypad can store up to 4 configuration programs for any *DURAPULSE* drive. This is great for maintenance backup as well as OEM programming ease.

U.S. operating parameters

DURAPULSE drives are specifically designed to operate with U.S. voltage levels.

Encoder feedback

Optional encoder feedback module allows additional control routine for speed control



Sensorless Vector Technology up to 100 hp

DURAPULSE AC Inverters

Hp	Part Number	Output Amps	Price (US\$)	Part Number	Output Amps	Price (US\$)
1.0	GS3-21P0	5	\$242.00	GS3-41P0	2.7	\$323.00
2.0	GS3-22P0	7	\$293.00	GS3-42P0	4.2	\$360.00
3.0	GS3-23P0	11	\$347.00	GS3-43P0	5.5	\$385.00
5.0	GS3-25P0	17	\$400.00	GS3-45P0	8.5	\$427.00
7.5	GS3-27P5	25	\$549.00	GS3-47P5	13	\$613.00
10	GS3-2010	33	\$698.00	GS3-4010	18	\$734.00
15	GS3-2015	49	\$889.00	GS3-4015	24	\$957.00
20	GS3-2020	65	\$1,104.00	GS3-4020	32	\$1,165.00
25	GS3-2025	75	\$1,298.00	GS3-4025	38	\$1,383.00
30	GS3-2030	90	\$1,486.00	GS3-4030	45	\$1,570.00
40	GS3-2040	120	\$2,177.00	GS3-4040	60	\$2,001.00
50	GS3-2050	145	\$2,637.00	GS3-4050	73	\$2,436.00
60	n/a	n/a	n/a	GS3-4060	91	\$2,788.00
75	n/a	n/a	n/a	GS3-4075	110	\$3,130.00
100	n/a	n/a	n/a	GS3-4100	150	\$3,498.00

Accessories

- AC line reactors
- EMI filters
- Braking resistors
- Fuse kits and replacement fuses
- RF filter
- GS3-FB feedback card
- Ethernet interface
- GSoft drive configuration software
- Replacement keypads
- Remote panel adapter
- Keypad cables in 1, 3 and 5 meter lengths
- Four and eight-port communication boards

LCD Display

LCD display for real language programming. No need to have a manual to understand parameter configuration.

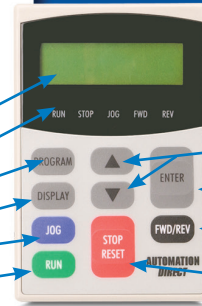

- LCD Display
- LED Indicators
- Program Key
- Display Key
- Jog Key
- Run Key
- Up/Down Keys
- Enter Key
- Fwd/Rev Key
- Stop/Reset Key

The lit LED Indicators will blink when there is a Fault or a Warning.

Remote mounting of keypad

Standard keypad mounted on unit's face can also be remote mounted for easy access to data and parameters. Requires remote cable.



The DURAPULSE Digital Keypad

The digital keypad includes a 2 line x 16 character LCD display, 5 status LED Indicators, and 9 function keys. The diagram above shows all of the features of the digital keypad.

The standard smart keypad (aka HIM or Human Interface Module) is designed with defaults for the North American customer and allows you to configure the drive, set the speed, start and stop the drive, and monitor critical parameters for your application. In addition, this keypad has internal memory that allows four complete programs to be stored and transferred to any DURAPULSE drive.

Drives	AutomationDirect DURAPULSE	VS.	Allen-Bradley Powerflex 40	Our Price vs A-B
10 hp, 240V	\$698.00 GS3-2010		\$1,880.00 22B-B033N104	63% Savings
5 hp, 460V	\$427.00 GS3-45P0		\$1,160.00 22B-D010N104	63% Savings
10 hp, 460V	\$734.00 GS3-4010		\$1,750.00 22B-D017N104	58% Savings

All prices are U.S. published prices. AutomationDirect prices as of 4/18/16. Allen-Bradley prices taken from www.wernerelctric.com 5/25/2015. Prices subject to change without notice.

GSoft Configuration Software

GSoft configuration software is a Windows-based package that allows connection from a PC to any GS or DURAPULSE drive for easy configuration and tuning. You can create new drive configurations, upload and download archived configurations, and tune the drive's PID loop with intuitive screens. GSoft is available as a free download from our Web site.

GSoft configuration software available for free download (CD available for \$9).
www.automationdirect.com/pn/gsoft

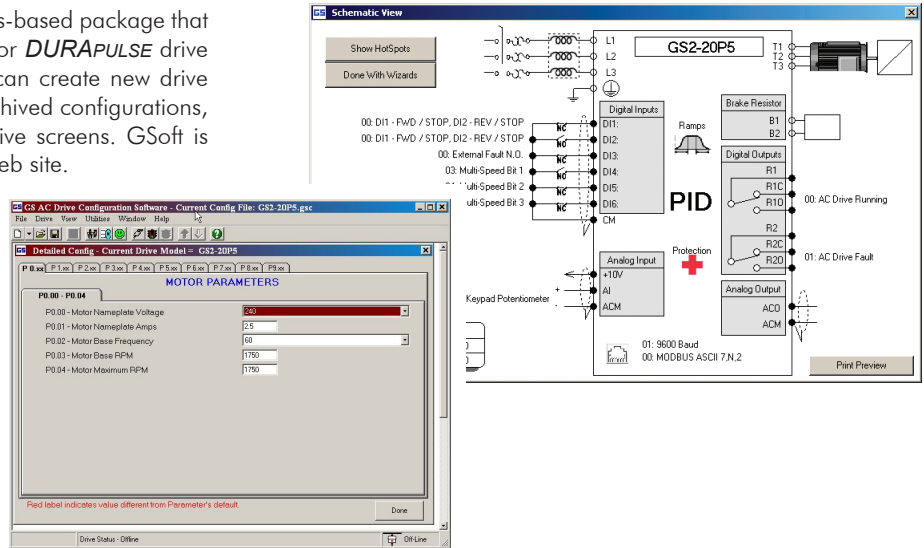

Networking AC Drives with Built-in Modbus Communications

AUTOMATIONDIRECT's AC drives offer "out-of-the-box" RS-232 (GS2 series only) and RS-485 serial connectivity. Modbus RTU is the onboard standard protocol used for control and monitoring. This can be used to connect several Modbus masters like AUTOMATIONDIRECT's family of *Direct*LOGIC PLCs, and Think & Do Studio, and any OPC server that has a Modbus driver such as Kepware or Software Toolbox.

Imagine getting all the parameter settings and control functionality on one cable, even when the information is not readily available by any other means. This flexibility offers cost savings, standardization, smaller PLC usage, and less development time.

See the Motor Controller Communications table further in this section for creating plug-and-play serial networks with drives and PLCs.



RS-485 Modbus Network

Add Ethernet Connectivity for Advanced Functionality

Add Ethernet connectivity and open up the path to the most advanced functionality today.

The GS-EDRV100 provides a high-performance Ethernet link between a control system and a **DURAPULSE** or GS drive. It mounts on DIN rail and connects a drive to an Ethernet hub or PC. The GS-EDRV100 processes signals to and from the drive and formats them to conform with the Ethernet standard required by the H2-ERM or H4-ERM, Productivity3000/2000, **KEPDirect** OPC Server or **KEPDirect** EBC I/O Server (as shown below), or an independent controller with the Modbus TCP/IP driver. This allows for greater connectivity to many control system architectures.

An additional feature is the built-in Web server, which allows users to configure and control the drive from any web browser via the IP address of the GS-EDRV100 card. The **DURAPULSE** and GS series drives have a provision for shutting down control or power to the inverter in the event of a communications timeout. This function can be set up through the drive parameter group 9 on all the drive platforms.

The **KEPDirect** OPC Server and **KEPDirect** EBC I/O Server software packages provide a way to connect your favorite Windows client software to **AUTOMATIONDIRECT** Ethernet I/O through our Ethernet base controllers. They provide GS series drive support via the GS-EDRV100 Ethernet interface, as shown in the diagram below. **KEPDirect** allows the user a direct line into the drive parameter group just like an Ethernet field I/O drop. The user can control or monitor from any OPC/DDE compliant third party software. For a complete description of **KEPDirect** software features, go to the Software section of this catalog. Several application notes specific to the versatility of this software can be found on our web site at www.automationdirect.com.



Modbus® TCP/IP



3 Steps to Selecting the Right AC Drive



STEP 1 - Select The Right Model

A. Determine motor voltage, horsepower and full-load amperage

	AC drive models		
	GS1	GS2	DURAPULSE
Horsepower	1/4 - 2	1/4 - 10*	1-100**
Input voltage	115/230 VAC	115/230/460/575 VAC	230/460 VAC
Motor voltage	230 VAC	230/460/575 VAC	230/460 VAC

* 230V up to 7.5 hp
460V up to 10 hp
575V up to 10 hp

** 230V up to 50 hp
460V up to 100 hp

Check the nameplate on the motor for specs needed:

Motor horsepower →

Motor voltage →

Motor amperage →

Inverter Duty Motor					
HP	1	Volts	460	PHASE	3
RPM	1725	AMPS	2.6	HZ	60
DESIGN	B	AMB	40°C	INSUL CLASS	F
DUTY	CONT	ENCL	TEFC	CODE	K

Motor voltage, horsepower, and amperage can be found on the motor's nameplate.

Note: Most motors can be connected for multiple voltages and will have multiple amperages listed.

In the example to the left the motor can be connected for 460V only. The 460V amperage is 2.6.

B. Select your application and/or control mode

	AC Drive Models		
	GS1	GS2	DURAPULSE
Volts/Hertz Control	✓	✓	✓
Sensorless Vector Control		✓	✓
Closed Loop Control			Optional
Encoder Feedback			Optional
Integral PID Control		✓	✓
Integral Dynamic Braking Unit		✓	15 HP*
Conveyor	Conveyor	Conveyor	Conveyor
Pump	Pump	Pump	Pump
Fan	Fan	Fan	Fan
Shop tools	Shop tools	Shop tools	Shop tools
		Material handling	Material handling
		HVAC	HVAC
		Mixing	Mixing
		Compressor	Compressor
		Shop tools	Shop tools

Either choose your application from those listed or select the control mode that meets your application's requirements. For applications not listed, either select the control mode that offers the same or higher level of performance as the existing control, or call us and ask for assistance.

	Control Mode		
	Volts/Hertz	Sensorless Vector	Closed-Loop Control
Complexity	Low	Moderate	Complex
Performance	Good	Good	High
1 min. Overload	150%	150%	150%
Starting Torque	175%	200%	200%
Speed Regulation	+/- 2%	+/- 1%	+/- 0.2%

*15 hp requires external braking units



C. Determine the I/O requirements of the AC drive

	AC Drive Models		
	GS1	GS2	DURAPULSE
Digital Inputs	4	6	11
Digital Outputs - Transistor	0	0	3
Digital Outputs - Relay	1	2	1
Digital Output - Frequency pulse			1
Analog Input - 0-10VDC/4-20mA	1	1	3
Analog Output - 0 - 10 VDC	0	1	1

Digital inputs are used to interface the AC drive with devices such as pushbuttons, selector switches and PLC digital output modules, either DC or relay. These signals are typically used for functions such as Start/Stop, Forward/Reverse, External Fault, Preset Speed selection, Fault Reset, etc.

Digital outputs are typically used to connect the AC drive to devices such as pilot lights, alarms, auxiliary relays, solenoids,

and PLC digital input modules. Relay outputs are rated for both AC and DC voltages. Transistor outputs are rated for only DC voltages.

The analog input is used to interface the AC drive with an external 0-10 VDC or 4-20 mA signal. This signal can represent either a speed setpoint or if available, PID feedback.

D. Determine location of AC drive's keypad

Removable Keypad	AC Drive Models		
	GS1	GS2	DURAPULSE
		✓	✓

The keypad of the GS2, DURApulse are removable and can be remotely mounted. If the AC drive is installed in a location that the operator cannot easily access, its keypad could be relocated

to a more suitable location. Remote mounting would require the purchase of the appropriate cable. Also available for the DURApulse drives is a remote, panel-mount bezel.

E. Determine communications requirements

MODBUS Communications Ethernet Communications	AC Drive Models		
	GS1	GS2	DURAPULSE
	Optional	Optional	Optional

A serial communication interface can be used to connect the AC drive to other devices that have the capability to function as a master device. The master device can control the AC drive with this interface instead of using the digital and analog I/O. The master can also use this interface to monitor the status of various AC drive parameters, speed, current, fault status, etc.

The GS1, GS2 and DURApulse AC drives have a standard Modbus RS-485 interface.

The GS1, GS2, and DURApulse drives also have the optional capability to communicate through an Ethernet interface. Please refer to the technical section of each model to determine the required Ethernet interface adapter and compatible Ethernet devices.

F. Select the proper series

After you have selected the AC drive series that meets your requirements, you need to determine the correct rating. Turn the page and proceed to Step two.



STEP 2

STEP 2 - Select the Proper Rating

A. Determine motor full load amperage (FLA)

Motor FLA is located on the nameplate of the motor.

Note: FLA of motors that have been rewound may be higher than stated.

B. Determine overload requirements

Many applications experience temporary overload conditions due to starting requirements or impact loading. Most AC drives are designed to operate at 150% overload for 60 seconds. If the application requires an overload greater than 150% or longer than 60 seconds, the AC drive must be oversized. NOTE: Applications that require replacement of existing motor starters with AC drives may require up to 600% overload.

C. Installation altitude

AC drives rely upon the cooling properties of air for cooling. As the altitude increases, the air becomes less dense. This decrease in air density decreases the cooling properties of the air. Therefore, the AC drive must be oversized to compensate for the decrease in cooling. Most AC drives are designed to operate at 100% capacity up to altitudes of 1000 m. Above 1000 m, the AC drive must be derated.

D. Determine max enclosure internal temp

AC drives generate a significant amount of heat and will cause the internal temperature of an enclosure to exceed the rating of the AC drive, even when the ambient temperature is less than 104 degrees F (40 degrees C). Enclosure ventilation and/or cooling may be required to maintain a maximum internal temperature of 104 degrees F (40 degrees C) or less. Ambient temperature measurements/calculations should be made for the maximum expected temperature.

E. Calculate required output amperage

Use the chart below to calculate the required FLA of the AC drive. Select the rating that equals the motor's voltage and equals or exceeds the calculated amperage.

		Example 1	Example 2
		GS Series DURAPULSE	
		ENTER Motor FLA	
Overload Derate (overload %)	If Overload is less than 150% and less than 60 seconds, Then ENTER 1		
	If Overload is greater than 150% and less than 60 seconds, Then ENTER (overload/150%)	1.333	
	If Overload is greater than 60 seconds, Then ENTER (overload/100%) Multiply FLA x overload entry (This entry is the overload result)	8	10.8
Altitude Derate (meters)	If Altitude is less than 1000m Then ENTER 1	1	
	If Altitude is more than 1000m and less than 3000m Then ENTER 1+ ((altitude-1000) x 0.0001) Multiply overload result x altitude entry (This entry is the altitude result)	8	10.91
Ambient Temperature (Celsius)	If Max enclosure internal temperature (MEIT) is less than 40°C Then ENTER 1		1
	If 40°C < MEIT < 50°C and GS series AC drive up to 5 hp Then ENTER 1	1	
	If 40°C < MEIT < 50°C and GS Series >5 hp or DURAPULSE series AC drive Then ENTER 1.2		
Multiply altitude result x MEIT entry (This result is the required drive FLA)		8	10.91



STEP 3

STEP 3 - Options, Options, and more Options

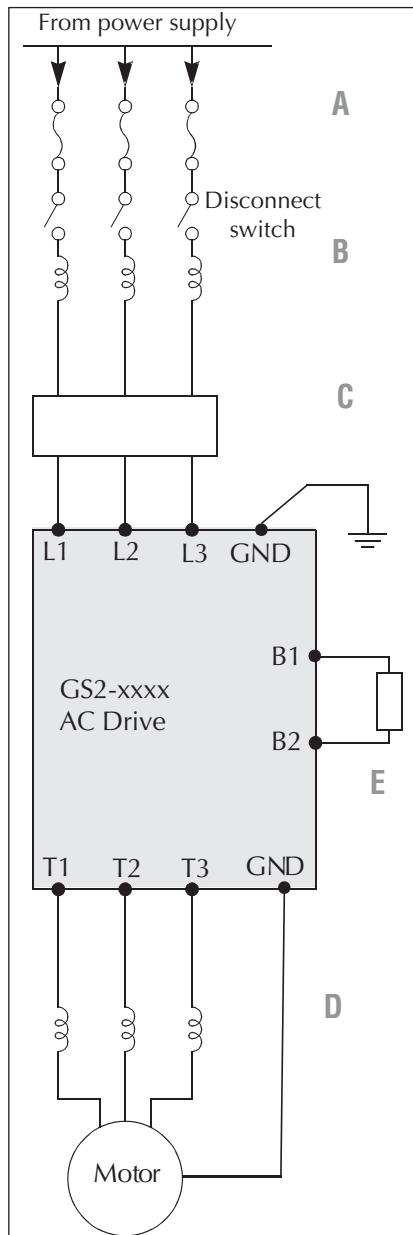

A. Input fuses

Input fuses protect the AC drive from excessive input current due to line surges, short circuits, and ground faults. They are recommended for all installations and may be required for UL-listed installations. Input fuse kits and replacement fuses are available for GS series and *DURAPULSE* AC drives.

B. Input line reactor

Input line reactors protect the AC drive from transient overvoltage conditions, typically caused by utility capacitor switching. The input line reactor also reduces the harmonics associated with AC drives. Input line reactors are recommended for all installations.

C. Input EMI filter

Input EMI filters reduce electromagnetic interference or noise on the input side of the inverter. They are required for CE compliance and recommended for installations prone to or sensitive to electromagnetic interference.

D. Output line reactor

Output line reactors protect the motor insulation against drive short circuits and IGBT reflective wave damage. Output line reactors also "smooth" the motor current waveform, allowing the motor to run cooler. The line reactor can be used for either input or output applications.

Output line reactors are recommended for operating "noninverter-duty" motors and when the length of wiring between the AC drive and motor is longer than the recommended max length of a given motor model. Inverter-duty rated motors support longer lead length than do non-inverter duty motors.

E. Dynamic braking

Dynamic braking allows the AC drive to produce additional braking (stopping) torque. AC drives can typically produce between 15% and 20% braking torque without the addition of any external components. The GS2 and *DURAPULSE* AC drives have built-in braking circuits on all units below 15 hp. These drives still require the addition of a braking resistor to increase their braking torque capability. Ratings larger than 15 hp require separate braking units in addition to the braking resistors to increase their braking torque capability.

Dynamic braking may be required for applications requiring rapid deceleration or high inertia loads.

GS1 Series Introduction



GS1 Series Drives					
Motor Rating	hp	0.25	0.5	1	2
	kW	0.2	0.4	0.75	1.5
115V Single-Phase Input / 230V Three-Phase Output		✓	✓		
230V Single-Phase Input / 230V Three-Phase Output		✓	✓	✓	
230V Three-Phase Input / Output					✓

Overview

The GS1 series of AC drives is our most affordable and compact inverter, offering V/Hz control with general purpose application features. These drives can be configured using the built-in digital keypad (which also allows you to set the drive speed, start and stop, and monitor specific parameters) or with the standard RS-485 serial communications port. Standard GS1 features include one analog input, four programmable digital inputs and one programmable normally open relay output.

Features

- Simple Volts/Hertz control
- Pulse Width Modulation (PWM)
- 3 – 10 kHz carrier frequency
- IGBT technology
- 130% starting torque at 5Hz
- 150% rated current for one minute
- Electronic overload protection
- Stall prevention
- Adjustable accel and decel ramps
- S-curve settings for acceleration and deceleration
- Manual torque boost
- Automatic slip compensation
- DC braking
- Built-in EMI filter
- Three skip frequencies
- Trip history
- Integral keypad and speed potentiometer
- Programmable jog speed
- Three programmable preset speeds
- Four programmable digital inputs
- One programmable analog input
- One programmable relay output
- RS-485 Modbus communications up to 19.2K
- Optional Ethernet communications
- DIN rail or panel mountable
- Two-year warranty
- UL/cUL/CE listed

Accessories

- AC line reactors
- RF filter
- Fuse kits and replacement fuses
- Ethernet interface
- Four and eight-port RS-485 multi-drop termination board
- Serial communication cables available for creating plug and play RS-232/RS-485 networks with AutomationDirect PLCs. See the comm cable matrix on page 92.
- KEP*Direct* I/O or OPC Server
- GSoft drive configuration software
- USB-485M – USB to RS-485 PC adapter (see “Communications Products” chapter for detailed information)

Detailed descriptions and specifications for GS accessories are available in the “GS/DURAPULSE Accessories” section.

Typical Applications

- Conveyors
- Fans
- Pumps
- Shop tools

GS1 series part numbering system

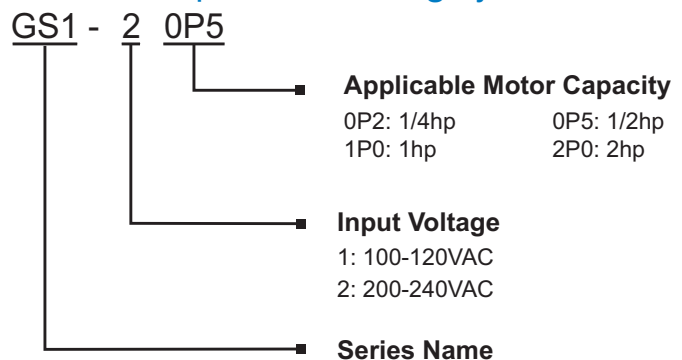

GS1 Series Specifications

115V/230V CLASS GS1 Series							
Model		GS1-10P2	GS1-10P5	GS1-20P2	GS1-20P5	GS1-21P0	GS1-22P0
Price		\$99.00	\$117.00	\$113.00	\$117.00	\$134.00	\$164.00
Motor Rating	HP	1/4 hp	1/2 hp	1/4 hp	1/2 hp	1hp	2hp
	kW	0.2 kW	0.4 kW	0.2 kW	0.4 kW	0.7 kW	1.5 kW
Rated Output Capacity (200V) kVA		0.6	1.0	0.6	1.0	1.6	2.7
Rated Input Voltage		Single-phase: 100–120 VAC ±10%; 50/60 Hz ±5%		Single/three-phase: 200–240 VAC ±10%; 50/60 Hz ±5%		Three-phase: 200–240 VAC ±10%; 50/60 Hz ±5%	
Rated Output Voltage		Three-phase corresponds to double the input voltage		Three-phase corresponds to the input voltage			
Rated Input Current (A)		6	9	4.9/1.9	6.5/2.7	9.7/5.1	9
Rated Output Current (A)		1.6	2.5	1.6	2.5	4.2	7.0
Watt Loss @ 100% I (W)		19.2	19.2	18.4	26.8	44.6	73
Weight: kg (lb)		2.10	2.20	2.20	2.20	2.20	2.20
Dimensions (HxWxD) (mm [in])		132.0 x 68.0 x 128.1 [5.20 x 2.68 x 5.04]					
Accessories							
Line Reactor *		LR-1xxPx-xxx (refer to "GS/DURApulse Drives Accessories – Line Reactors" section for exact part #)					
RF Filter		RF220X00A					
Fuse Kit **	Single-Phase**	GS-10P2-FKIT-1P	GS-10P5-FKIT-1P	GS-20P2-FKIT-1P	GS-20P5-FKIT-1P	GS-21P0-FKIT-1P	–
	Three-Phase	–	–	GS-20P2-FKIT-3P	GS-20P5-FKIT-3P	GS-21P0-FKIT-3P	GS-22P0-FKIT-3P
Replacement Fuses	Single-Phase	GS-10P2-FUSE-1P	GS-10P5-FUSE-1P	GS-20P2-FUSE-1P	GS-20P5-FUSE-1P	GS-21P0-FUSE-1P	–
	Three-Phase	–	–	GS-20P2-FUSE-3P	GS-20P5-FUSE-3P	GS-21P0-FUSE-3P	GS-22P0-FUSE-3P
Ethernet Communications module for GS Series Drives (DIN rail mounted)		GS-EDRV100					
USB to RS-485 PC Communication Adapter		USB-485M					
RS-485 Communication Distribution Module (for creating plug and play RS-485 networks)		ZL-CDM-RJ12X4 / ZL-CDM-RJ12X10					
RS-485 Serial Cable, GS Drive to DL06/D2-260		GS-485HD15-CBL-2					
RS-485 Serial Cable, GS Drive to ZIPLink CDM Module		GS-485RJ12-CBL-2					
Software		GSoft / KEPDirect					
OPC Server		KEPDirect					
* GS1-1xxx drives require 115V class input line reactors and 230V class output line reactors.							
** Single-phase fuse kits and fuses are used only with GS1-1xxx drives.							

GS1 General Specifications

General Specifications			
Control Characteristics			
Control System	Sinusoidal Pulse Width Modulation, carrier frequency 3kHz–10kHz		
Rated Output Frequency	1.0 to 400.0 Hz limited to 9999 motor rpm		
Output Frequency Resolution	0.1 Hz		
Overload Capacity	150% of rated current for 1 minute		
Torque Characteristics	Includes manual torque boost, auto-slip compensation, starting torque 130% @ 5.0Hz		
DC Braking	Operation frequency 60–0Hz, 0–30% rated voltage. Start time 0.0–5.0 seconds. Stop time 0.0–25.0 seconds		
Acceleration/Deceleration Time	0.1 to 600 seconds (can be set individually)		
Voltage/Frequency Pattern	V/F pattern adjustable. Settings available for Constant Torque – low and high starting torque, Variable Torque – low and high starting torque, and user configured		
Stall Prevention Level	20 to 200% of rated current		
Operation Specification			
Inputs	Frequency Setting	Keypad	Setting by <UP> or <DOWN> buttons or potentiometer
		External Signal	Potentiometer - 5k Ω 0.5W, 0 to 10 VDC (input impedance 47k Ω), 0 to 20 mA / 4 to 20 mA (input impedance 250 Ω), Multi-function inputs 1 to 3 (3 steps, JOG, UP/DOWN command), RS485 communication setting
	Operation Setting	Keypad	Setting by <RUN>, <STOP> buttons
		External Signal	DI1, DI2, DI3, DI4 can be combined to offer various modes of operation, RS485 communication port
Outputs	Multi-Function Input Signal		Multi-step selection 0 to 3, Jog, Accel/decel inhibit, First/second accel/decel switch, Counter, PLC operation, External base block (N.C., N.O.) selection
	Multi-Function Output Signal		AC drive operating, Frequency attained, Non zero speed, Base Block, Fault indication, Local/remote indication, PLC operation indication
	Operating Functions		Automatic voltage regulation, S-curve, Over-voltage stall prevention, DC braking, Fault records, Adjustable carried frequency, Starting frequency setting of DC braking, Over-current stall prevention, Momentary power loss restart, Reverse inhibition, Frequency limits, Parameter lock/reset
Protective Functions			Overcurrent, overvoltage, undervoltage, electronic thermal motor overload, Overheating, Overload, Self testing
Operator Interface	Operator Devices		5-key, 4-digit, 7-segment LED, 3 status LEDs, potentiometer
	Programming		Parameter values for setup and review, fault codes
	Parameter Monitor		Master Frequency, Output Frequency, Scaled Output Frequency, Output Voltage, DC Bus Voltage, Output Direction, Trip Event Monitor, Trip History Monitor
	Key Functions		RUN/STOP, DISPLAY/RESET, PROGRAM/ENTER, <UP>, <DOWN>
Environment	Enclosure Rating		Protected chassis, IP20
	Ambient Operating Temperature		-10° to 40°C (14°F to 104°F) w/o derating
	Storage Temperature		-20° to 60 °C (-4°F to 140°F) during short-term transportation period)
	Ambient Humidity		0 to 90% RH (non-condensing)
	Vibration		9.8 m/s ² (1G), less than 10Hz; 5.88 m/s ² (0.6G) 20 to 50 Hz
Installation Location		Altitude 1000m or lower above sea level, keep from corrosive gas, liquid and dust	
Options			Programming Software (GSOFT)

GS1 Specifications - Installation

Understanding the installation requirements for your GS1 drive will help to ensure that it will operate within its environmental and electrical limits.

NOTE:
Never use only this catalog for installation instructions or operation of equipment; refer to the user manual, GS1-M.

Environmental Specifications	
Protective Structure ¹	IP20
Ambient Operating Temperature ²	-10 to 40°C
Storage Temperature ³	-20 to 60°C
Humidity	to 90% (no condensation)
Vibration ⁴	5.9 m/s ² (0.6g), 10 to 55 Hz
Location	Altitude 1,000 m or less, indoors (no corrosive gases or dust)

- 1: Protective structure is based upon EN60529
- 2: The ambient temperature must be in the range of -10° to 40° C. If the range will be up to 50° C, you will need to set the carrier frequency to 2.1 kHz or less and derate the output current to 80% or less. See our Web site for derating curves.
- 3: The storage temperature refers to the short-term temperature during transport.
- 4: Conforms to the test method specified in JIS C0911 (1984)

Watt Loss Chart	
GS1 Drive Model	At full load
GS1-10P2	19.2
GS1-10P5	19.2
GS1-20P2	18.4
GS1-20P5	26.8
GS1-21P0	44.6
GS1-22P0	73

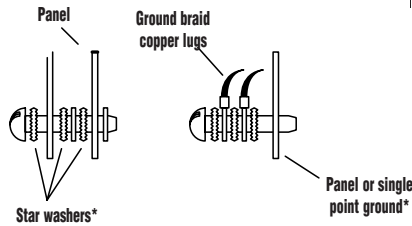
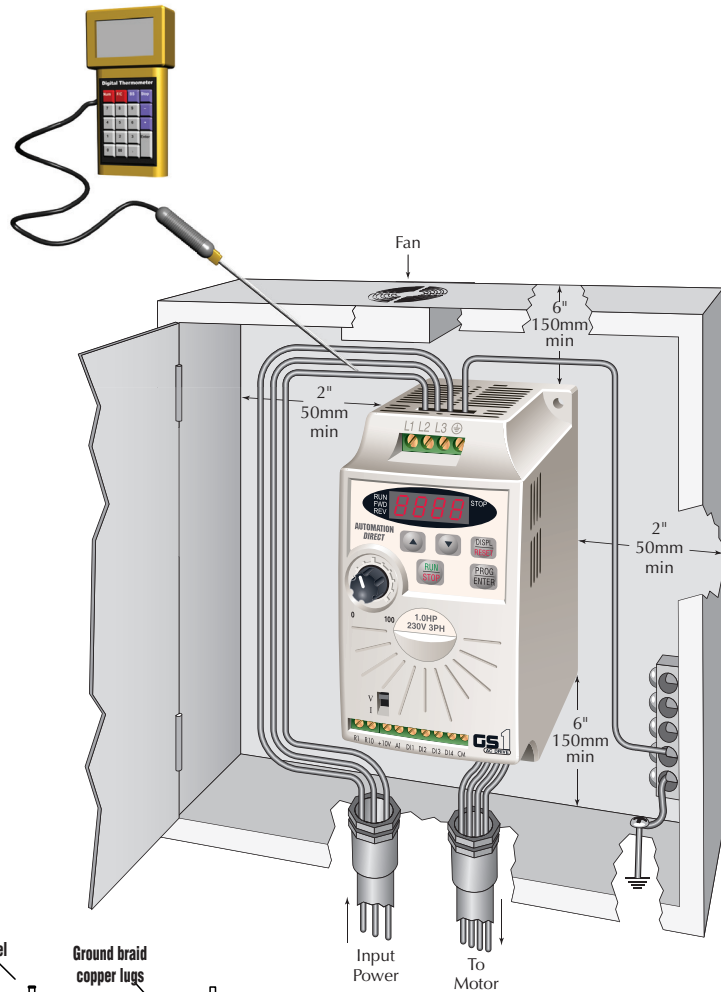

*** FOR PAINTED SUB-PANELS, SCRAPE THE PAINT FROM UNDERNEATH THE STAR WASHERS BEFORE TIGHTENING THEM.**



Warning: AC drives generate a large amount of heat, which may damage the AC drive. Auxiliary cooling methods are typically required in order to not exceed maximum ambient temperatures.

GS1 Specifications - Terminals

Main Circuit Wiring	
Terminal	Description
L1, L2, L3	Input power
T1, T2, T3	AC drive output
⊕	Ground

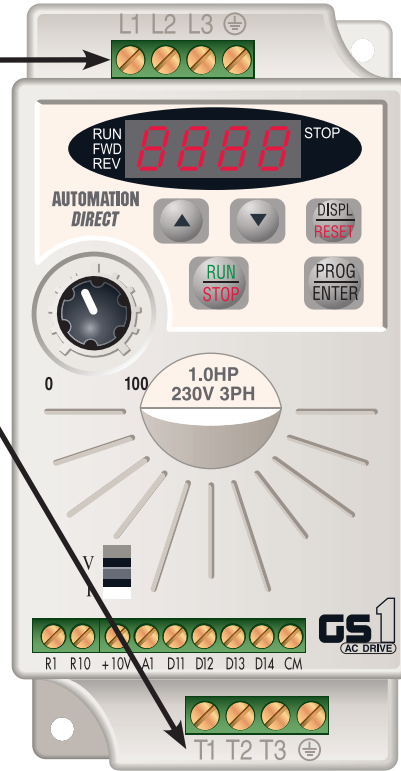
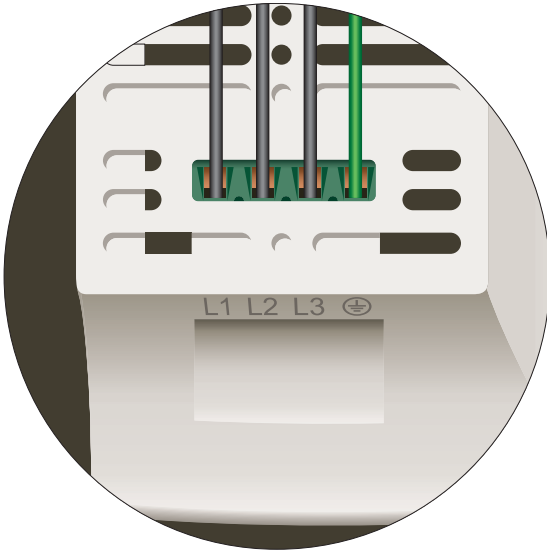

Control Circuit Terminals	
Terminal Symbol	Description
R10	Relay output 1 normally open
R1	Relay output 1 common
DI1	Digital input 1
DI2	Digital input 2
DI3	Digital input 3
DI4	Digital input 4
AI 1	Analog input
+10V	Internal power supply (10 mA @ 10 VDC)
CM	Common

¹ 0 to +10 VDC, 0 to 20 mA, or 4 to 20 mA input represents zero to maximum output frequency.

Note: Use twisted-shielded, twisted-pair or shielded-lead wires for the control signal wiring. It is recommended all signal wiring be run in a separate steel conduit. The shield wire should only be connected at the drive. Do not connect shield wire on both ends.

GS1 Specifications - Basic Wiring Diagram

Note: Users MUST connect wiring according to the circuit diagram shown below. (Refer to user manual GS1-M for additional specific wiring information.)

Note: Please refer to the following catalog pages in the Drives section* of our catalog for explanations and information regarding line reactors and RF filters: 49, 79.

Power Source 3-phase*

100-120V±10%
(50/60Hz ±5%)
200-240V±10%
(50/60Hz±5%)

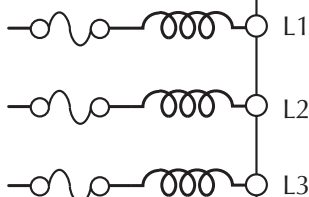

* Use terminals L1 and L2 for 120V, or select any two of the power terminals for 240V single-phase models

Grounding resistance less than 0.1Ω

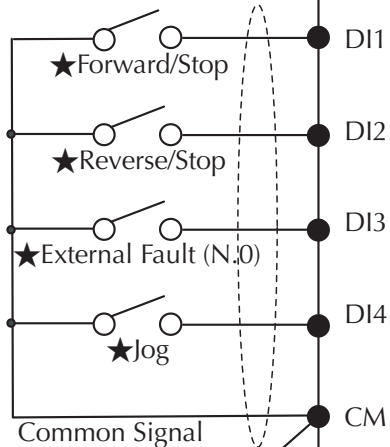

Analog voltage 0-10VDC

Potentiometer 3~5kΩ

Analog current 0-20mA; 4-20mA

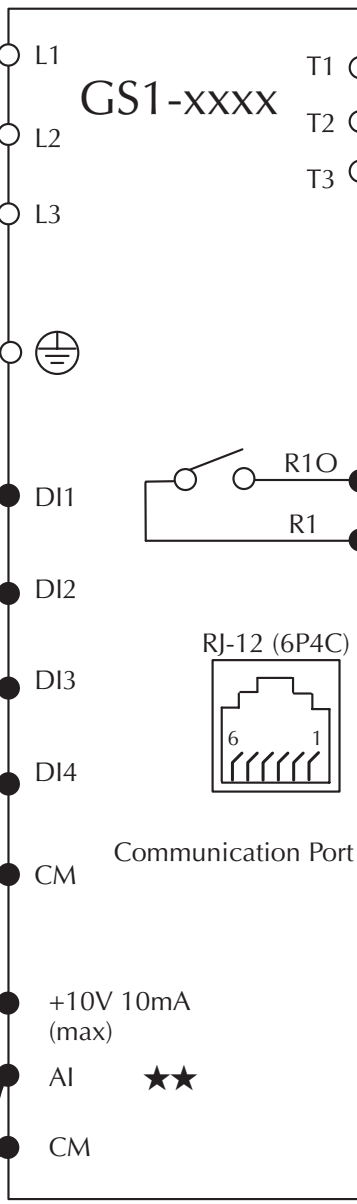

AC Motor



Multi-function output contacts
120VAC/24VDC @5A
230VAC @2.5A

★ Fault Indication

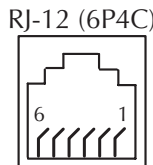

RJ-12 Serial Comm Port* Interface (See Warning)

RS-485

- 2: GND
- 3: SG-
- 4: SG+
- 5: +5V

*Optional ZIPLink serial communication cables available for plug and play connectivity to AutomationDirect PLCs. See the comm cable selection matrix on page 92.



★ Factory default setting

★★ Factory default source of frequency command is via the keypad potentiometer

○ Main circuit (power) terminals ● Control circuit terminal ⊕ Shielded leads



WARNING: Do not plug a modem or telephone into the GS1 RJ-12 Serial Comm Port, or permanent damage may result. Terminals 2 and 5 should not be used as a power source for your communication connection.

*The Drives section is in Book 2 of current version of our catalog, or you can download PDF of section here.

GS1 Specifications - Dimensions

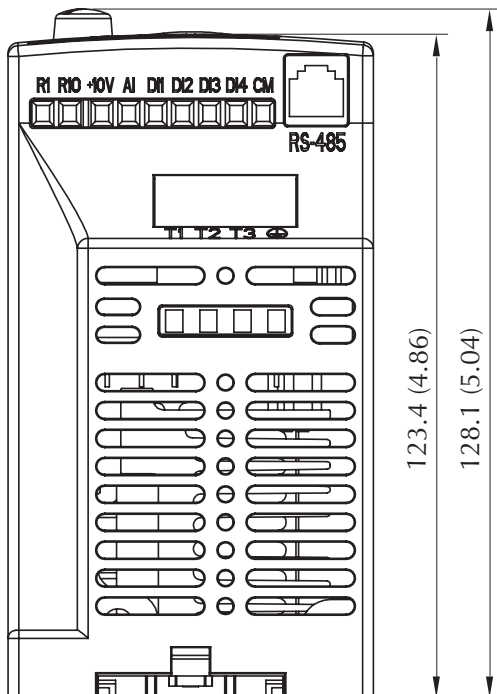
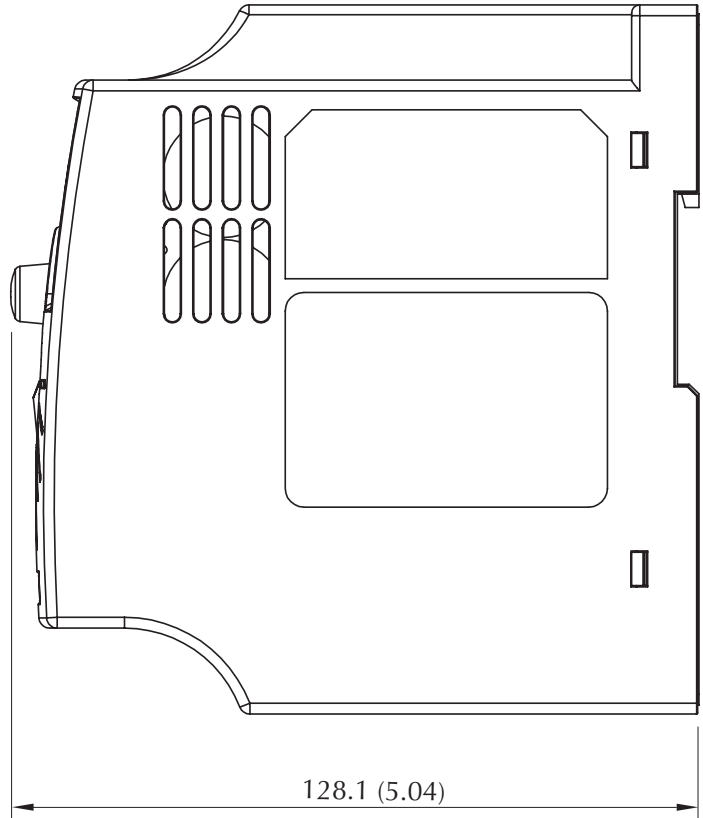
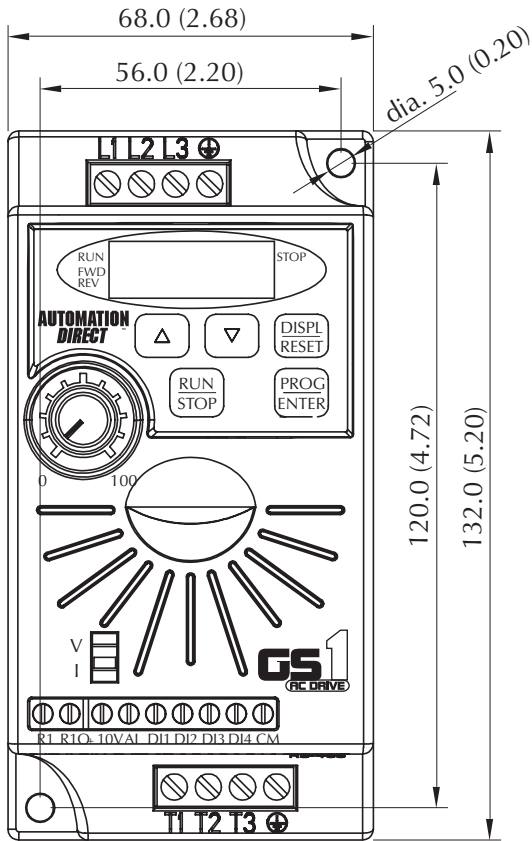

Unit: mm (in)

GS2 Series - Introduction



GS2 Series Drives									
Motor Rating	Hp	0.25	0.5	1	2	3	5	7.5	10
	kW	0.2	0.4	0.75	1.5	2.2	3.7	5.5	7.5
Single-Phase Input 115V Class		✓	✓	✓					
Single/Three-Phase Input 230V Class			✓	✓	✓	✓			
Three-Phase 230V Class							✓	✓	
Three-Phase 460V Class				✓	✓	✓	✓	✓	✓
Three-Phase 575V Class				✓	✓	✓	✓	✓	✓

Overview

The GS2 series of AC drives offers all of the features of our GS1 drive plus dynamic braking, PID and a removable keypad. The drive can be configured using the built-in digital keypad or with the standard RS-232/RS-485 serial communications port. The standard keypad allows you to configure the drive, set the speed, start and stop the drive, command forward and reverse direction of motor shaft, and monitor specific parameters during operation. Each GS2 features one analog and six programmable digital inputs, and one analog and two programmable relay outputs.

Features

- Simple Volts/Hertz control
- Sinusoidal Pulse Width Modulation (PWM)
- 1-12 kHz carrier frequency
- IGBT technology
- Starting torque: 125% at 0.5 Hz/150% at 5 Hz
- 150% rated current for one minute
- Electronic overload protection
- Stall prevention
- Adjustable accel and decel ramps
- S-curve settings for acceleration and deceleration
- Automatic torque compensation
- Automatic slip compensation
- Dynamic braking circuit
- DC braking
- Three skip frequencies
- Trip history
- Programmable jog speed
- Integral PID control
- Removable keypad with speed potentiometer
- Programmable analog input
- Programmable analog output
- Six programmable digital inputs
- Two programmable relay outputs
- RS-232/485 Modbus communications up to 38.4 Kbps.
- Optional Ethernet communications
- Two-year warranty
- UL/cUL/CE* listed
* GS2-5xxx 575V drives NOT CE compliant

Accessories

- AC line reactors
- EMI filters
- RF filter
- Braking resistors
- Fuse kits and replacement fuses
- DIN rail mounting adapter (see "Accessories" table for applicability)
- Replacement keypads
- Keypad cables in 1, 3, and 5-meter lengths
- Ethernet interface
- Four and eight-port serial communication breakout boards
- KEPDirect I/O or OPC Server
- Serial communication cables available for creating plug and play RS-232/RS-485 networks with AutomationDirect PLCs. See the comm cable matrix on page 92
- GSoft drive configuration software
- USB-485M – USB to RS-485 PC adapter (see "Communications Products" chapter for detailed information)

Detailed descriptions and specifications for GS accessories are available in the "GS/DURAPULSE Accessories" section.

Typical Applications

- Conveyors
- Fans
- Pumps
- Compressors
- HVAC
- Material handling
- Mixing
- Shop tools

GS2 series part numbering system

GS2- 4 7P5

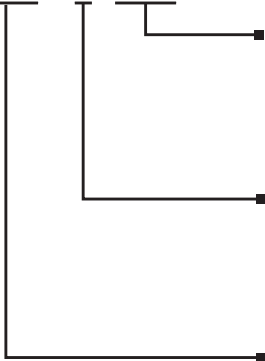

Applicable Motor Capacity

0P2: 0.25HP 0P5: 0.5HP
 1P0: 1.0HP 2P0: 2.0HP
 3P0: 3.0HP 5P0: 5.0HP
 7P5: 7.5HP 010: 10HP

Input Voltage

1: 100-120VAC
 2: 200-240VAC
 4: 380-480VAC
 5: 500-600VAC

Series Name

GS2 Series Specifications

115V CLASS GS2 SERIES				
Model		GS2-10P2	GS2-10P5	GS2-11P0
Price		\$156.00	\$166.00	\$186.00
Motor Rating	HP	1/4hp	1/2hp	1hp
	kW	0.2kW	0.4kW	0.75kW
Rated Output Capacity (kVA)		0.6	1.0	1.6
Rated Input Voltage		Single-phase : 100 to 120 VAC \pm 10% 50/60 Hz \pm 5%		
Rated Output Voltage		Three-phase, two times proportion to input voltage		
Rated Input Current (A)		6	9	16
Rated Output Current (A)		1.6	2.5	4.2
DC Braking		Frequency 60–0 Hz, 0–100% rated current, start time 0.0–5.0 seconds, Stop Time 0.0–25.0 seconds		
Watt Loss @ 100% I (W)		24	34	46
Weight (lb)		3.5	3.6	3.7
Dimensions*** (HxWxD) (mm [in])		151.0 x 100.0 x 140.5 [5.94 x 3.94 x 5.53]		
Accessories				
Line Reactor	Input side of drive (1 Phase)*	LR-10P2-1PH	LR-10P5-1PH	LR-11P0-1PH
	Output side of drive (3 Phase)*	LR-20P5		LR-21P0
Braking Resistor		GS-20P5-BR	GS-20P5-BR	GS-21P0-BR
EMI Filter		20DRT1W3S		
RF Filter		RF220X00A		
Fuse Kit	Single Phase**	GS-10P2-FKIT-1P	GS-10P5-FKIT-1P	GS-11P0-FKIT-1P
Replacement Fuses	Single Phase**	GS-10P2-FUSE-1P	GS-10P5-FUSE-1P	GS-11P0-FUSE-1P
DIN Rail Mounting Adapter		GS2-DR02		
Spare Keypad, GS2 Series Drive		GS2-KPD		
Keypad Cable, GS2 Series, 1 meter		GS-CBL2-1L		
Keypad Cable, GS2 Series, 3 meter		GS-CBL2-3L		
Keypad Cable, GS2 Series, 5 meter		GS-CBL2-5L		
Ethernet Communications module for GS Series Drives (DIN rail mounted)		GS-EDRV100		
USB to RS232 PC Communication Adapter		USB-RS232		
RS-232 Serial Cable, GS2 Drive to DL05/06, CLICK, D2-250/260, D4-450, P3-550		GS-RJ12-CBL-2		
USB to RS-485 PC Communication Adapter		USB-485M		
RS-485 Communication Distribution Module (for creating plug and play RS-485 networks)		ZL-CDM-RJ12X4 / ZL-CDM-RJ12X10		
RS-485 Serial Cable, GS Drive to DL06/D2-260		GS-485HD15-CBL-2		
RS-485 Serial Cable, GS Drive to ZIPLink CDM Module		GS-485RJ12-CBL-2		
Software		GSoft / KEP Direct		
OPC Server		KEP Direct		
*Note: GS2-1xxx drives require 115V class input line reactors and 230V class output line reactors.				
**Note: Single phase fuse kits and fuses are used only with GS2-1xxx drives.				
***Note: Height dimension does not include external ground terminal, which adds 10 to 15 mm. Refer to dimensional drawings for details.				

GS2 Series Specifications

230V CLASS GS2 SERIES							
Model		GS2-20P5	GS2-21P0	GS2-22P0	GS2-23P0	GS2-25P0	GS2-27P5
Price		\$158.00	\$177.00	\$251.00	\$309.00	\$363.00	\$465.00
Motor Rating	HP	1/2hp	1hp	2hp	3hp	5hp	7.5hp
	kW	0.4kW	0.75kW	1.5kW	2.2kW	3.7kW	5.5kW
Rated Output Capacity (kVA)		1.0	1.9	2.7	3.8	6.5	9.5
Rated Input Voltage		Single/Three-phase : 200/208/220/230/240 VAC ±10%; 50/60Hz ±5%				Three-phase : 200/208/220/230/240 VAC ±10%; 50/60 Hz ±5%	
Rated Output Voltage		Three-phase : Corresponds to input voltage					
Rated Input Current (A)		6.3/2.9	11.5/6.3	15.7/8.8	27.0/12.5	19.6	28
Rated Output Current (A)		2.5	5.0	7.0	10	17	25
DC Braking		Frequency 60–0 Hz, 0–100% rated current, start time 0.0–5.0 seconds, Stop Time 0.0–25.0 seconds					
Watt Loss @ 100% I (W)		34	57	77	111	185	255
Weight (lb)		3.5	3.6	3.7	8.5	8.5	8.5
Dimensions* (HxWxD) (mm [in])		151.0 x 100.0 x 140.5 [5.94 x 3.94 x 5.53]			220.0 x 125.0 x 189.5 [8.66 x 4.92 x 7.46]		
Accessories							
Line Reactor	Single-Phase	LR-20P5-1PH	LR-21P0-1PH	LR-22P0-1PH	LR-23P0-1PH	n/a	n/a
	Three-Phase	LR-20P5	LR-21P0	LR-22P0	LR-23P0	LR-25P0	LR-27P5
Braking Resistor		GS-20P5-BR	GS-21P0-BR	GS-22P0-BR	GS-23P0-BR	GS-25P0-BR	GS-27P5-BR
EMI Filter (single phase input)		20DRT1W3S			32DRT1W3C	40TDS4W4B	
RF Filter		RF220X00A					
Fuse Kit	Single-Phase	GS-20P5-FKIT-1P	GS-21P0-FKIT-1P	GS-22P0-FKIT-1P	GS-23P0-FKIT-1P	N/A	N/A
	Three-Phase	GS-20P5-FKIT-3P	GS-21P0-FKIT-3P	GS-22P0-FKIT-3P	GS-23P0-FKIT-3P	GS-25P0-FKIT-3P	GS-27P5-FKIT
Replacement Fuses	Single-Phase	GS-20P5-FUSE-1P	GS-21P0-FUSE-1P	GS-22P0-FUSE-1P	GS-23P0-FUSE-1P	N/A	N/A
	Three-Phase	GS-20P5-FUSE-3P	GS-21P0-FUSE-3P	GS-22P0-FUSE-3P	GS-23P0-FUSE-3P	GS-25P0-FUSE	GS-27P5-FUSE
DIN Rail Mounting Adapter		GS2-DR02			n/a		
Spare Keypad, GS2 Series Drive						GS2-KPD	
Keypad Cable, GS2 Series, 1 meter						GS-CBL2-1L	
Keypad Cable, GS2 Series, 3 meter						GS-CBL2-3L	
Keypad Cable, GS2 Series, 5 meter						GS-CBL2-5L	
Ethernet Communications module for GS Series Drives (DIN rail mounted)						GS-EDRV100	
USB to RS232 PC Communication Adapter						USB-RS232	
RS-232 Serial Cable, GS2 Drive to DL05/06, CLICK, D2-250/260, D4-450, P3-550						GS-RJ12-CBL-2	
USB to RS-485 PC Communication Adapter						USB-485M	
RS-485 Communication Distribution Module (for creating plug and play RS-485 networks)						ZL-CDM-RJ12X4 / ZL-CDM-RJ12X10	
RS-485 Serial Cable, GS Drive to DL06/D2-260						GS-485HD15-CBL-2	
RS-485 Serial Cable, GS Drive to ZIPLink CDM Module						GS-485RJ12-CBL-2	
Software						GSoft / KEPDirect	
OPC Server						KEPDirect	
<i>*Note: Height dimension does not include external ground terminal, which adds 10 to 15 mm. Refer to dimensional drawings for details.</i>							

GS2 Series Specifications

460V CLASS GS2 SERIES							
Model	GS2-41P0	GS2-42P0	GS2-43P0	GS2-45P0	GS2-47P5	GS2-4010	
Price	\$261.00	\$303.00	\$357.00	\$410.00	\$586.00	\$725.00	
Motor Rating	HP	1hp	2hp	3hp	5hp	7.5hp	10hp
	kW	0.8kW	1.5kW	2.2kW	4kW	5.5kW	7.5kW
Rated Output Capacity (kVA)	2.3	3.1	3.8	6.2	9.9	13.7	
Rated Input Voltage	Three-phase: 380/400/415/440/460/480 VAC \pm 10%; 50/60 Hz \pm 5%						
Rated Output Voltage	Corresponds to input voltage						
Rated Input Current (A)	4.2	5.7	6.0	8.5	14	23	
Rated Output Current (A)	3.0	4.0	5.0	8.2	13	18	
DC Braking	Frequency 60–0 Hz, 0–100% rated current, Start Time 0.0–5.0 seconds, Stop Time 0.0–25.0 seconds						
Watt Loss @ 100% I (W)	73	86	102	170	240	255	
Weight (lb)	3.5	3.6	3.7	8.5	8.5	8.5	
Dimensions* (HxWxD) (mm [in])	151.0 x 100.0 x 140.5 [5.94 x 3.94 x 5.53]			220.0 x 125.0 x 189.5 [8.66 x 4.92 x 7.46]			
Accessories							
Line Reactor	LR-41P0	LR-42P0	LR-43P0	LR-45P0	LR-47P5	LR-4010	
Braking Resistor	GS-41P0-BR	GS-42P0-BR	GS-43P0-BR	GS-45P0-BR	GS-47P5-BR	GS-4010-BR	
EMI Filter	11TDT1W4S			17TDT1W44		26TDT1W4B4	
RF Filter	RF220X00A						
Fuse Kit	GS-41P0-FKIT	GS-42P0-FKIT	GS-43P0-FKIT	GS-45P0-FKIT	GS-47P5-FKIT	GS-4010-FKIT	
Replacement Fuses	GS-41P0-FUSE	GS-42P0-FUSE	GS-43P0-FUSE	GS-45P0-FUSE	GS-47P5-FUSE	GS-4010-FUSE	
DIN Rail Mounting Adapter	GS2-DR02			n/a			
Spare Keypad, GS2 Series Microdrive	GS2-KPD						
Keypad Cable, GS2 Series, 1 meter	GS-CBL2-1L						
Keypad Cable, GS2 Series, 3 meter	GS-CBL2-3L						
Keypad Cable, GS2 Series, 5 meter	GS-CBL2-5L						
Ethernet Communications Module for GS Series Drives (DIN rail mounted)	GS-EDRV100						
USB to RS232 PC Communication Adapter	USB-RS232						
RS-232 Serial Cable, GS2 Drive to DL05/06, CLICK, D2-250/260, D4-450, P3-550	GS-RJ12-CBL-2						
USB to RS-485 PC Communication Adapter	USB-485M						
RS-485 Communication Distribution Module (for creating plug and play RS-485 networks)	ZL-CDM-RJ12X4 / ZL-CDM-RJ12X10						
RS-485 Serial Cable, GS Drive to DL06/D2-260	GS-485HD15-CBL-2						
RS-485 Serial Cable, GS Drive to ZIPLink CDM Module	GS-485RJ12-CBL-2						
Software	GSoft / KEP Direct						
OPC Server	KEP Direct						
<i>*Note: Height dimension does not include external ground terminal, which adds 10 to 15 mm. Refer to dimensional drawings for details.</i>							

GS2 Series Specifications

575V CLASS GS2 SERIES							
Model		GS2-51P0	GS2-52P0	GS2-53P0	GS2-55P0	GS2-57P5	GS2-5010
Price		\$279.00	\$319.00	\$378.00	\$491.00	\$721.00	\$812.00
Motor Rating	HP	1hp	2hp	3hp	5hp	7.5hp	10hp
	kW	0.75kW	1.5kW	2.2kW	3.7kW	5.5kW	7.5kW
Rated Output Capacity (kVA)		1.7	3.0	4.2	6.6	9.9	12.2
Rated Input Voltage		Three-phase: 500 to 600 VAC -15/+10%; 50/60 Hz ±5%					
Rated Output Voltage		Corresponds to input voltage					
Rated Input Current (A)		2.4	4.2	5.9	7.0	10.5	12.9
Rated Output Current (A)		1.7	3.0	4.2	6.6	9.9	12.2
DC Braking		Frequency 60-0 Hz, 0-100% rated current, Start Time 0.0-5.0 seconds, Stop Time 0.0-25.0 seconds					
Watt Loss @ 100% I (W)		30	58	83	132	191	211
Weight (lb)		3.3	3.3	4.4	7.0	7.0	7.3
Dimensions* (HxWxD) (mm [in])		151.0 x 100.0 x 140.5 [5.94 x 3.94 x 5.53]			220.0 x 125.0 x 189.5 [8.66 x 4.92 x 7.46]		
Accessories							
Line Reactor		LR-51P0	LR-52P0	LR-53P0	LR-55P0	LR-5010	
Braking Resistor		GS-42P0-BR		GS-42P0-BR x (2) in parallel			GS-4010-BR x (2) in series
EMI Filter		not available					
RF Filter		RF220X00A					
Fuse Block (Edison 3-pole part #)		BC6033PQ or CHCC3D or CHCC3DI					
Replacement Fuses (Edison Fuse part #)		HCLR6 (10 fuses per pack)	HCLR10 (10 fuses per pack)	HCLR15 (10 fuses per pack)		HCLR20 (10 fuses per pack)	HCLR30 (10 fuses per pack)
DIN Rail Mounting Adapter		GS2-DR02			n/a		
Spare Keypad, GS2 Series Microdrive		GS2-KPD					
Keypad Cable, GS2 Series, 1 meter		GS-CBL2-1L					
Keypad Cable, GS2 Series, 3 meter		GS-CBL2-3L					
Keypad Cable, GS2 Series, 5 meter		GS-CBL2-5L					
Ethernet Communications Module for GS Series Drives (DIN rail mounted)		GS-EDRV100					
USB to RS232 PC Communication Adapter		USB-RS232					
RS-232 Serial Cable, GS2 Drive to DL05/06, CLICK, D2-250/260, D4-450, P3-550		GS-RJ12-CBL-2					
USB to RS-485 PC Communication Adapter		USB-485M					
RS-485 Communication Distribution Module (for creating plug and play RS-485 networks)		ZL-CDM-RJ12X4 / ZL-CDM-RJ12X10					
RS-485 Serial Cable, GS Drive to DL06/D2-260		GS-485HD15-CBL-2					
RS-485 Serial Cable, GS Drive to ZIPLink CDM Module		GS-485RJ12-CBL-2					
Software		GSoft / KEPDirect					
OPC Server		KEPDirect					
*Note: Height dimension does not include external ground terminal, which adds 10 to 15 mm. Refer to dimensional drawings for details.							

GS2 Series — General Specifications

General Specifications			
Control Characteristics			
Control System	Sinusoidal Pulse Width Modulation, carrier frequency 1kHz–12kHz		
Output Frequency Resolution	0.1 Hz		
Overload Capacity	150% of rated current for 1 minute		
Torque Characteristics	Includes auto-torque boost, auto-slip compensation, starting torque 125% @ 0.5Hz/150% @ 5.0Hz		
Braking Torque	20% without dynamic braking resistor, 125% with optional braking resistor		
DC Braking	Operation frequency 60–0 Hz, 0–100% rated current. Start time 0.0–5.0 seconds. Stop time 0.0–0.25.0 seconds		
Acceleration/Deceleration Time	0.1 to 600 seconds (linear or non-linear acceleration/deceleration), second acceleration/deceleration available		
Voltage/Frequency Pattern	V/F pattern adjustable. Settings available for Constant Torque - low and high starting torque, Variable Torque - low and high starting torque, and user configured		
Stall Prevention Level	20 to 200% or rated current		
Operation Specifications			
Inputs	Frequency Setting	Keypad	Setting by <UP> or <DOWN> buttons or potentiometer
		External Signal	Potentiometer - 3k to 5k Ω /2W, 0 to 10VDC (input impedance 10k Ω), 0 to 20mA / 4 to 20 mA (input impedance 250 Ω), Multi-speed inputs 1 to 3, Serial Communication RS232 and RS485 (Modbus RTU)
	Operation Setting	Keypad	Setting by <RUN>, <STOP> buttons
		External Signal	Forward/Stop, Reverse/Stop (run/stop, fwd/rev), 3-wire control, Serial Communication RS232 and RS485 (Modbus RTU)
Input Terminals	Digital	6 user-programmable: FWD/STOP, REV/STOP, RUN/STOP, REV/FWD, Run momentary (N.O.), STOP momentary (N.C.), External Fault (N.O./N.C.), External Reset, Multi-Speed Bit (1–3), Jog, External Base Block (N.O./N.C.), Second Accel/Decel Time, Speed Hold, Increase Speed, Decrease Speed, Reset Speed to Zero, PID Disable (N.O.), PID Disable (N.C.), Input Disable	
	Analog	1 user-configurable, 0 to 10VDC (input impedance 10k Ω) or 0 to 20mA / 4 to 20mA (input impedance 250 Ω), 10 bit resolution Frequency setpoint or PID process variable PV	
Outputs	Output Terminals	Digital	2 user-programmable: Inverter Running, Inverter Fault, At Speed, Zero Speed, Above Desired Frequency, Below Desired Frequency, At Maximum Speed, Over Torque Detected, Above Desired Current, Below Desired Current, PID Deviation Alarm
		Analog	1 user-programmable: 0 to 10VDC (max load 2mA), 8 bit resolution frequency, current, process variable PV
	Operating Functions	Automatic voltage regulation, voltage/frequency characteristics selection, non-linear acceleration/deceleration, upper and lower frequency limiters, 7-stage speed operation, adjustable carrier frequency (1 to 12 kHz), PID control, skip frequencies, analog gain & bias adjustment, jog, electronic thermal relay, automatic torque boost, trip history, software protection	
Protective Functions			Electronic Thermal, Overload Relay, Auto Restart after Fault, Momentary Power Loss, Reverse Operation Inhibit, Auto Voltage Regulation, Over-Voltage Trip Prevention, Auto Adjustable Accel/Decel, Over-Torque Detection Mode, Over-Torque Detection Level, Over-Torque Detection Time, Over-Current Stall Prevention during Acceleration, Over-Current Stall Prevention during Operation
Operator Interface	Operator Devices		8-key, 4-digit, 7-segment LED, 14 status LEDs, potentiometer
	Programming		Parameter values for setup and review, fault codes
	Status Display		Actual Operating Frequency, RPM, Scaled Frequency, Amps, % Load, Output Voltage, DC Bus Voltage, Process Variable, Set-point Frequency
	Key Functions		RUN, STOP/RESET, FWD/REV, PROGRAM, DISPLAY, <UP>, <DOWN>, ENTER
Environment	Enclosure Rating		Protected chassis, IP20
	Ambient Temperature		-10° to 50°C (14°F to 122°F) -10° to 40°C (14°F to 104°F) For models 7.5 hp (5.5 kW) and higher
	Storage Temperature		-20° to 60 °C (-4°F to 140°F) - during short-term transportation period
	Ambient Humidity		20 to 90% RH (non-condensing)
	Vibration		9.8 m/s ² (1G), less than 10Hz; 5.9 m/s ² (0.6G) 10 to 60 Hz
Installation Location		Altitude 1000m or lower above sea level, keep from corrosive gas, liquid and dust	
Options			Noise filter, input AC reactor, output AC reactor, cable for remote operator, programming software (GSOFT), Dynamic braking resistor, input fuses, ethernet interface (GS-EDRV100), EMI filters

GS2 Specifications — Installation

Understanding the installation requirements for your GS2 drive will help to ensure that it operates within its environmental and electrical limits.

Note: Never use only this catalog for installation instructions or operation of equipment; refer to the user manual, GS2-M.

Environmental Specifications	
Protective Structure ¹	IP20
Ambient Operating Temperature ²	-10 to 50°C (14°F to 122°F) -10 to 40°C (14°F to 104°F) for models 7.5HP and higher
Storage Temperature ³	-20 to 60°C (-4°F to 140°F)
Humidity	To 90% (no condensation)
Vibration ⁴	5.9 m/s ² (0.6g), 10 to 55 Hz
Location	Altitude 1,000 m or less, indoors (no corrosive gases or dust)

1: Protective structure is based upon EN60529

2: The ambient temperature must be in the range of -10° to 40° C. If the range will be up to 50° C, you will need to set the carrier frequency to 2.1 kHz or less and derate the output current to 80% or less. See our Web site for derating curves.

3: The storage temperature refers to the short-term temperature during transport.

4: Conforms to the test method specified in JIS C0911 (1984)

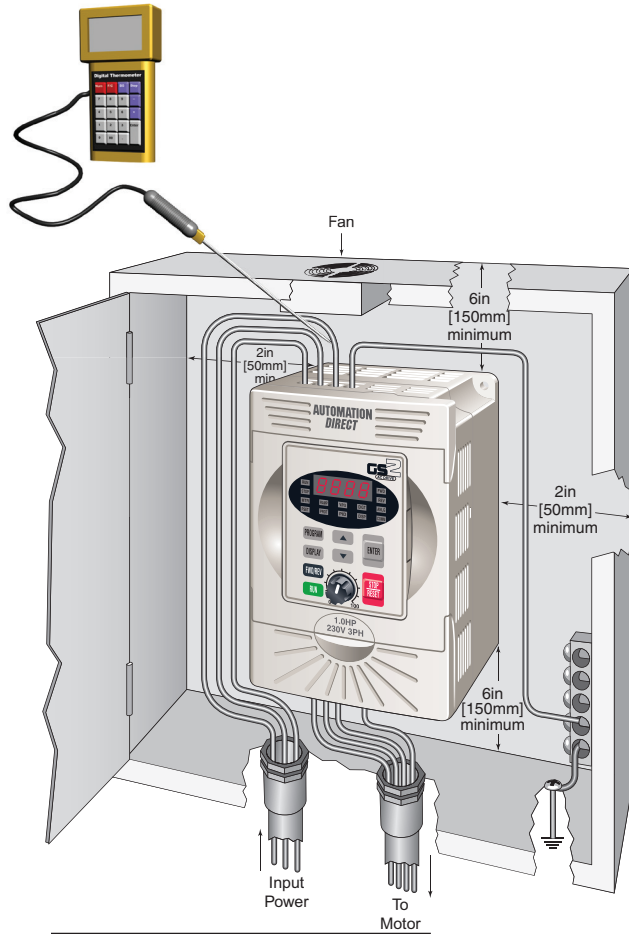

Warning: Maximum ambient temperatures must not exceed 50°C (122°F), or 40°C (104°F) for models 7.5 hp (5.5 kW) and higher!

Watt-loss Chart	
GS2 Drive Model	At full load
GS2-10P2	24
GS2-10P5	34
GS2-11P0	46
GS2-20P5	34
GS2-21P0	57
GS2-22P0	77
GS2-23P0	111
GS2-25P0	185
GS2-27P5	255
GS2-41P0	73
GS2-42P0	86
GS2-43P0	102
GS2-45P0	170
GS2-47P5	240
GS2-4010	255
GS2-51P0	30
GS2-52P0	58
GS2-53P0	83
GS2-55P0	132
GS2-57P5	191
GS2-5010	211



Warning: AC drives generate a large amount of heat which may damage the AC drive. Auxiliary cooling methods are typically required in order not to exceed maximum ambient temperatures.

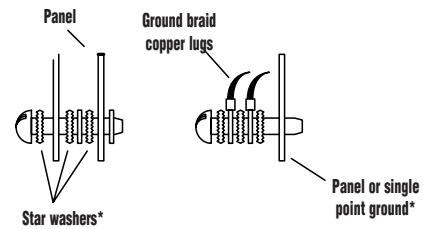

*** FOR PAINTED SUB-PANELS, SCRAPE THE PAINT FROM UNDERNEATH THE STAR WASHERS BEFORE TIGHTENING THEM.**

GS2 Specifications — Terminals

Main Circuit Wiring	
Terminal	Description
L1, L2, L3	Input power
T1, T2, T3	AC drive output
B1, B2	DB resistor input
	Ground

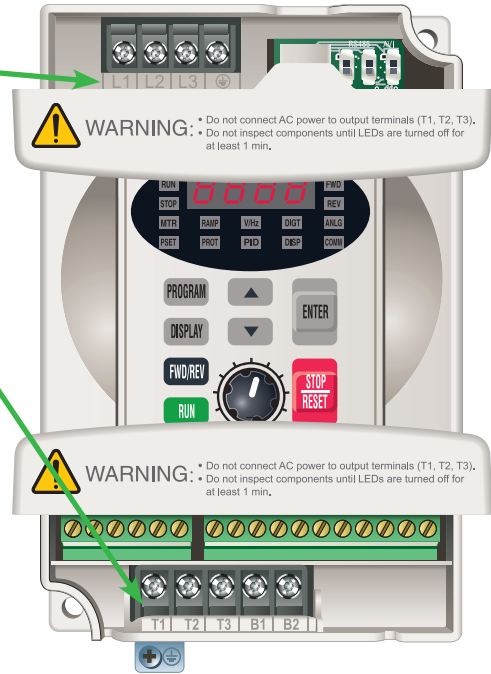
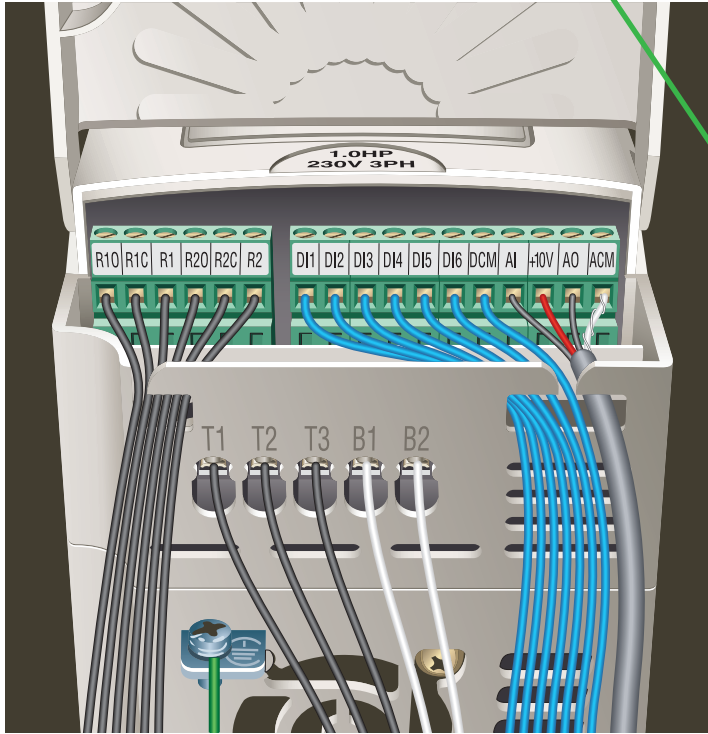

Control Circuit Terminals	
Terminal Symbol	Description
R10	Relay output 1 normally open
R1C	Relay output 1 normally closed
R1	Relay output 1 common
R20	Relay output 2 normally open
R2C	Relay output 2 normally closed
R2	Relay output 2 common
DI1	Digital input 1
DI2	Digital input 2
DI3	Digital input 3
DI4	Digital input 4
DI5	Digital input 5
DI6	Digital input 6
DCM	Digital common
AI	Analog input
+10V	Internal power supply (DC 10V) @ 10 mA
AO	Analog output
ACM	Analog common

Note: Use twisted-shielded, twisted-pair or shielded-lead wires for the control signal wiring. It is recommended to run all signal wiring in a separate steel conduit. The shield wire should only be connected at the drive. Do not connect shield wire on both ends.

GS2 Specifications — Basic Wiring Diagram

Company Information

Drives

Soft Starters

Motors

Power Transmission

Motion: Servos and Steppers

Motor Controls

Sensors: Proximity

Sensors: Photoelectric

Sensors: Encoders

Sensors: Limit Switches

Sensors: Current

Sensors: Pressure

Sensors: Temperature

Sensors: Level

Sensors: Flow

Pushbuttons and Lights

Stacklights

Signal Devices

Process

Relays and Timers

Pneumatics: Air Prep

Pneumatics: Directional Control Valves

Pneumatics: Cylinders

Pneumatics: Tubing

Pneumatics: Air Fittings

Appendix Book 2

Terms and Conditions

Note: Users MUST connect wiring according to the circuit diagram shown below. (Refer to user manual GS2-M for additional specific wiring information.)

Note: Please refer to the following catalog pages in the Drives section* of our catalog for explanations and information regarding line reactors, braking resistors, EMI and RF filters, and fuses: 49, 68, 73, 79, 80.

Power Source*

- 100-120V ±10%
- 200-240V ±10%
- 380-480V ±10%
- 500-600V -15%;+10%
- (50,60Hz ±5%)

* Use terminals L1, L2 for 115V 1-phase models; use any two of L1, L2, L3 for 230V 1-phase models.

Grounding resistance less than 0.1Ω

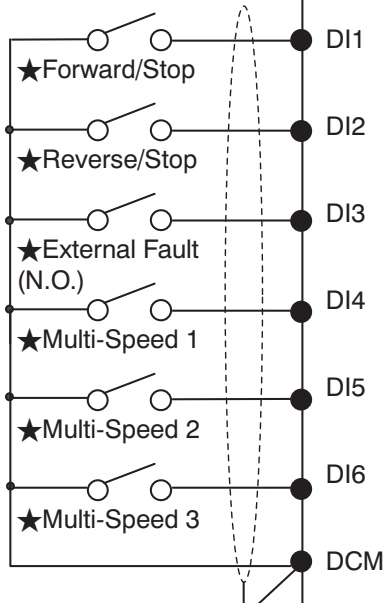

- Analog voltage 0-10 VDC
- Potentiometer 3-5 kΩ
- Analog current 0-20 mA
- 4-20 mA

GS2-xxxx

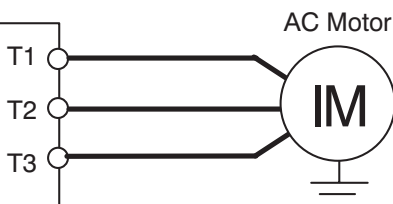

B1, B2 terminals connected to a Braking resistor (optional).

R1, R1C, R1O terminals: Multi-function output contacts 120VAC/24VDC @5A, 230VAC @2.5A. R1O is Inverter Running.

R2, R2C, R2O terminals: Multi-function output contacts 120VAC/24VDC @5A, 230VAC @2.5A. R2O is Inverter Fault.

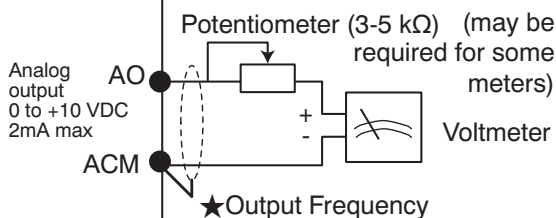

RJ-12 (6P4C)

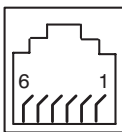

RJ-12 Serial Comm Port* Interface (See Warning)

RS-485	RS-232
2: GND	2: GND
3: SG-	3: RXD
4: SG+	4: TXD
5: +5V	5: +5V

- ★ Factory default setting
- ★★ Factory default source of frequency command is via the keypad potentiometer
- Main circuit (power) terminals ● Control circuit terminal ⊕ Shielded leads

*Optional ZIPLink serial communication cables available for plug and play connectivity to AutomationDirect PLCs. See the comm cable selection matrix on page 92.



WARNING: Do not plug a modem or telephone into the GS2 RJ-12 Serial Comm Port, or permanent damage may result. Terminals 2 and 5 should not be used as a power source for your communication connection.

*The Drives section is in Book 2 of current version of our catalog, or you can download PDF of section here.

GS2 Specifications — Dimensions

**GS2-10P2, GS2-10P5, GS2-11P0; GS2-20P5, GS2-21P0, GS2-22P0;
GS2-41P0, GS2-42P0, GS2-43P0; GS2-51P0, GS2-52P0, GS2-53P0**

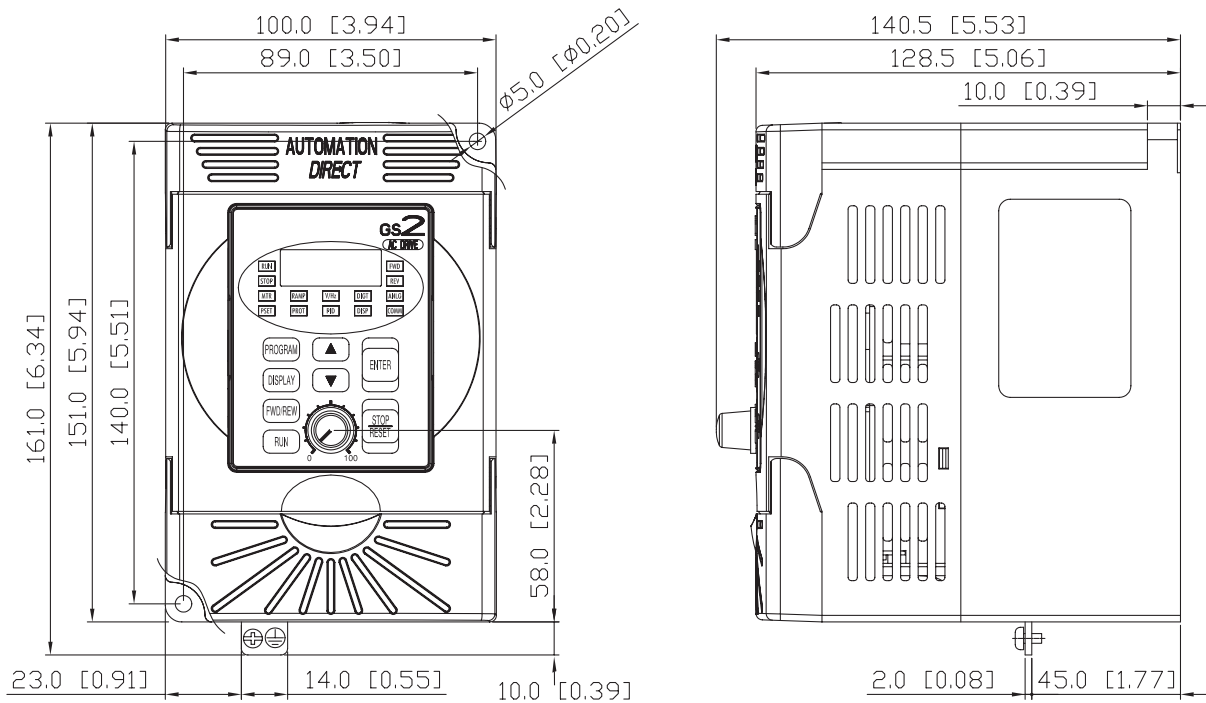

**GS2-23P0, GS2-25P0, GS2-27P5;
GS2-45P0, GS2-47P5, GS2-4010; GS2-55P0, GS2-57P5, GS2-5010**

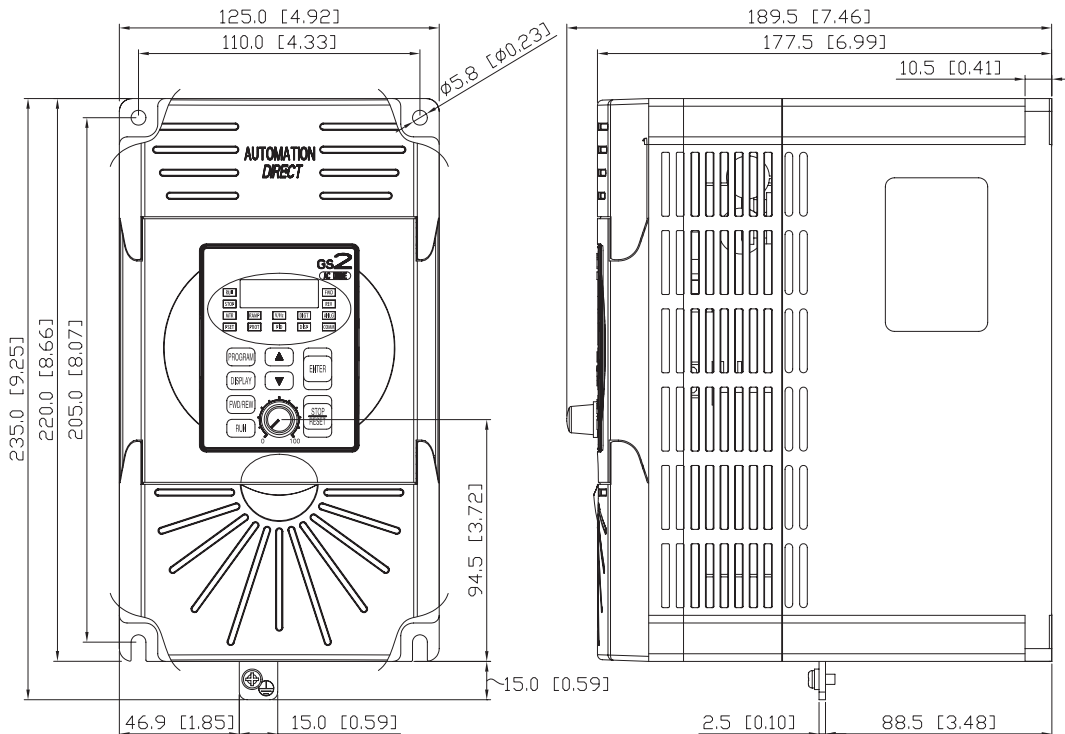

DURAPULSE AC Drives – Introduction



Overview

The *DURAPULSE* series of AC drives offers all of the features of our GS2 series of drives including dynamic braking, PID, removable keypad and RS-485 Modbus communication. The *DURAPULSE* AC drive also offers sensorless vector control with the option of encoder feedback for enhanced speed control. The standard **smart** keypad (or Human Interface Module) is designed with defaults for the North American customer and allows you to configure the drive, set the speed, start and stop the drive, and monitor critical parameters for your application. In addition, this keypad has internal memory that allows **four** complete programs to be stored and transferred to any *DURAPULSE* drive. The *DURAPULSE* series offers three analog inputs, eleven digital inputs, and one SPDT relay output.

DURApulse Drives																
Motor Rating	Hp	1	2	3	5	7.5	10	15	20	25	30	40	50	60	75	100
	kW	.75	1.5	2.2	3.7	5.5	7.5	11	15	18.5	22	30	37	45	55	75
Single/Three-Phase Input 230V		✓	✓	✓												
Three-Phase 230V Class					✓	✓	✓	✓	✓	✓	✓	✓	✓			
Three-Phase 460V Class		✓	✓	✓	✓	✓	✓	✓	✓	✓	✓	✓	✓	✓	✓	✓

Features

- Simple Volts/Hertz control
- Sensorless vector control with autotune
- Sensorless vector control with optional encoder feedback card, for better speed control
- Sinusoidal pulse width modulation (PWM)
- Variable carrier frequency, depending on model
- IGBT technology
- Starting torque: 125% @ 0.5 Hz/150% @ 1Hz
- 150% rated current for one minute
- Electronic overload protection
- Stall prevention
- Adjustable accel and decel ramps with linear and S-curve settings
- Automatic torque and slip compensation
- Internal dynamic braking circuit for models under 20 hp; optional baking units available for models 20 hp and above
- DC braking
- Five skip frequencies
- Trip history
- Programmable jog speed
- Integral PID control
- Removable **smart** keypad with parameter upload/download
- Keypad with memory to store up to four programs of any *DURAPULSE* drive
- Eleven programmable digital inputs
- Three programmable analog inputs
- Three digital and one SPDT relay programmable outputs
- One programmable analog output

- One digital frequency output
- RS-485 Modbus communications
- Ethernet communication optional
- Two-year warranty
- UL/cUL/CE listed

Accessories

- AC line reactors
- EMI filters
- RF filter
- Braking resistors
- Braking units (for models 20 hp and above)
- Fuse kits and replacement fuses
- Replacement cooling fans
- Remote panel adapter
- Replacement keypad
- Keypad cables in 1, 3, and 5-meter lengths
- Ethernet interface
- Four and eight-port RS-485 multi-drop termination boards
- KEPDirect I/O or OPC Server
- GSoft drive configuration software
- GS3-FB – feedback card
- GS-485HD15-CBL – **ZIPLink** RS485 communication cable for connection to the DL06 and D2-260 15-pin ports
- USB-485M – USB to RS-485 PC adapter (see “Communications Products” chapter for detailed information)

Detailed descriptions and specifications for GS accessories are available in the “GS/DURAPULSE Accessories” section.

Typical Applications

- Conveyors
- Fans
- Pumps
- Compressors
- HVAC
- Material handling
- Mixing
- Shop tools
- Extruding
- Grinding

DURAPULSE part numbering system

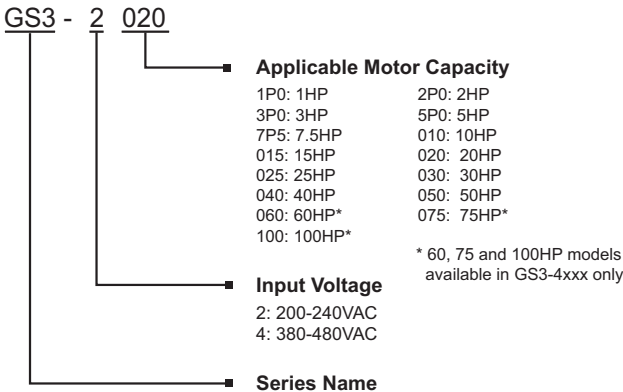

DURAPULSE AC Drives Specifications

230V Class														
Model Name: GS3-xxx		21P0	22P0	23P0	25P0	27P5	2010	2015	2020	2025	2030	2040	2050	
Price		\$242.00	\$293.00	\$347.00	\$400.00	\$549.00	\$698.00	\$889.00	\$1,104.00	\$1,298.00	\$1,486.00	\$2,177.00	\$2,637.00	
Output Rating	Maximum Motor Output	HP kW	1.0	2.0	3.0	5.0	7.5	10	15	20	25	30	40	50
	Rated Output Current (A)		.75	1.5	2.2	3.7	5.5	7.5	11	15	18.5	22	30	37
	Maximum Output Voltage	Three-phase 200 to 240V (proportional to input voltage)												
	Rated Frequency	0.1 to 400 Hz												
* Input Rating	Rated Voltage/Frequency	Single/Three-phase				Three-phase								
	Rated Input Current (A)	11.9 / 5.7	15.3 / 7.6	22 / 15.5	20.6	26	34	50	60	75	90	110	142	
Voltage/Frequency Tolerance		Voltage: ± 10% Frequency: ± 5%												
Watt Loss @ 100% I (W)		60	82	130	194	301	380	660	750	920	1300	1340	1430	
Weight (lb [kg])		4.5 [2.034]	4.5 [2.034]	9.4 [4.24]	9.4 [4.24]	13.3 [6.031]	13.3 [6.031]	14.3 [6.487]	26.5 [12]	26.5 [12]	26.5 [12]	77.2 [35]	77.2 [35]	
<p><i>* All 3-phase power sources must be symmetrical. Do not connect any DURApulse drives to grounded, center-tapped delta transformers (which are typically used for lighting circuits).</i></p>														

460V Class – Three-Phase																	
Model Name: GS3-xxx		41P0	42P0	43P0	45P0	47P5	4010	4015	4020	4025	4030	4040	4050	4060	4075	4100	
Price		\$323.00	\$360.00	\$385.00	\$427.00	\$613.00	\$734.00	\$957.00	\$1,165.00	\$1,383.00	\$1,570.00	\$2,001.00	\$2,436.00	\$2,788.00	\$3,130.00	\$3,498.00	
Output Rating	Maximum Motor Output	HP kW	1	2	3	5	7.5	10	15	20	25	30	40	50	60	75	100
	Rated Output Current (A)		.75	1.5	2.2	3.7	5.5	7.5	11	15	18.5	22	30	37	45	55	75
	Maximum Output Voltage	Three-phase 380 to 480V (proportional to input voltage)															
	Rated Frequency	0.1 to 400 Hz															
* Input Rating	Rated Voltage/Frequency	Three-phase, 380/400/415/440/460/480VAC, 50/60Hz															
	Rated Input Current (A)	3.2	4.3	5.9	11.2	14	19	25	32	39	49	60	63	90	130	160	
Voltage/Frequency Tolerance		Voltage: ± 10% Frequency: ± 5%															
Watt Loss @ 100% I (W)		70	102	132	176	250	345	445	620	788	1290	1420	1680	2020	2910	3840	
Weight (lb [kg])		3.9 [1.759]	4.4 [1.994]	4.1 [1.857]	9.4 [4.24]	13.2 [6.002]	13.5 [6.106]	14.4 [6.525]	26.5 [12]	26.5 [12]	26.5 [12]	77.2 [35]	77.2 [35]	77.2 [35]	116.8 [53]	116.8 [53]	
<p><i>* All 3-phase power sources must be symmetrical. Do not connect any DURApulse drives to grounded, center-tapped delta transformers (which are typically used for lighting circuits).</i></p>																	

DURAPULSE AC Drives General Specifications

General Specifications			
Control Characteristics			
Control System	Pulse Width Modulation, Carrier frequency adjustable from 1k–15kHz depending on the model. This system determines the control methods of the AC drive. 00: V/Hz open loop control 01: V/Hz closed loop control 02: Sensorless Vector 03: Sensorless Vector with external feedback		
Rated Output Frequency	0.1 to 400.0 Hz		
Output Frequency Resolution	0.1 Hz		
Overload Capacity	150% of rated current for 1 minute		
Torque Characteristics	Includes auto-torque boost, auto-slip compensation, starting torque 125% @ 0.5 Hz / 150% @ 1.0 Hz		
Braking Torque	20% without braking resistor, 125% with optional braking resistor (braking circuit built-in only for units under 20 hp)		
DC Braking	Operation frequency 60–0 Hz, 0–100% rated current, Start time 0.0–5.0 seconds, Stop time 0.0–25.0 seconds		
Acceleration/Deceleration Time	0.1 to 600 seconds (linear or non-linear acceleration/deceleration), second acceleration/deceleration available		
Voltage/Frequency Pattern	Settings available for Constant Torque - low & high starting torque, Variable Torque - low & high starting torque, and user configured		
Stall Prevention Level	20 to 200% of rated current		
Operation Specifications			
Inputs	Frequency Setting	Keypad	Setting by <UP> or <DOWN> buttons
		External Signal	Potentiometer - 3 to 5 kΩ, 0 to 10 VDC (input impedance 10 kΩ), -10 to +10 VDC, 4 to 20 mA (input impedance 250Ω), 0 to 20 mA; Multi-Speed Inputs 1 to 4, RS-232C/RS-485 communication interface
	Operation Setting	Keypad	Setting by <RUN>, <STOP>, <JOG>, <FWD>, <REV> buttons
		External Signal	Forward/Stop, Reverse/Stop (run/stop, fwd/rev), 3-wire control, Serial Communication RS-232C & RS-485 (Modbus RTU)
	Input Terminals	Digital Sink/Source Selectable	11 user-programmable: FWD/STOP, REV/STOP, RUN/STOP, REV/FWD, RUN momentary (N.O.), STOP momentary (N.C.), External Fault (N.O./N.C.), External Reset, Multi-Speed Bit (1-4), Manual Keyboard Control, Jog, External Base Block (N.O./N.C.), Second Accel/Decel Time, Speed Hold, Increase Speed, Decrease Speed, Reset Speed to Zero, PID Disable (N.O.), PID Disable (N.C.), Input Disable
		Analog	3 user-configurable, 0 to 10V (input impedance 10 kΩ), 0 to 20 mA, 4 to 20 mA (input impedance 250Ω), 10 bit resolution -10V to +10V, 10 bit resolution
Outputs	Output Terminals	Digital 3 transistors 1 relay	4 user-programmable: Inverter Running, Inverter Fault, At Speed, Zero Speed, Above Desired Frequency, Below Desired Frequency, At Maximum Speed, Over Torque Detected, Above Desired Current, Below Desired Current, PID Deviation Alarm, Heatsink Overheat Warning (OH), Soft Braking Signal, Above desired Frequency 2, Below desired Frequency 2, Encoder Loss
		Digital Square Wave	One digital square wave output representing drive frequency
		Analog	1 user-programmable, 0 to 10V, 8 bit resolution frequency, current, process variable PV
Operating Functions		Automatic voltage regulation, voltage/frequency characteristics selection, non-linear acceleration/deceleration, upper and lower frequency limiters, 15-stage speed operation, adjustable carrier frequency (1 to 15 kHz), PID control, 5 skip frequencies, analog gain & bias adjustment, jog, electronic thermal relay, automatic torque boost, trip history, software protection	
Protective Functions		Electronic Thermal, Overload Relay, Auto Restart after Fault, Momentary Power Loss, Reverse Operation Inhibit, Auto Voltage Regulation, Over-Voltage Stall Prevention, Auto Adjustable Accel/Decel, Over-Torque Detection Mode, Over-Torque Detection Level, Over-Torque Detection Time, Over-Current Stall Prevention during Acceleration, Over-Current Stall Prevention during Operation	
Operator Interface	Operator Devices		9-key, 2 line x 16 character LCD display, 5 status LEDs
	Programming		Parameter values for setup and review, fault codes
	Status Display		Output Frequency, Motor Speed, Scaled Frequency, Output Current, Motor Load, Output Voltage, DC Bus Voltage, PID Setpoint, PID Feedback, Frequency Setpoint
	Key Functions		RUN, STOP/RESET, FWD/REV, PROGRAM, DISPLAY, <UP>, <DOWN>, ENTER
Environment	Enclosure Rating		Protected Chassis, IP20
	Ambient Temperature		-10°C to 40°C (14°F to 104°F)
	Storage Temperature		-20°C to 60°C (-4°F to 140°F) – during short term transportation period
	Ambient Humidity		20 to 90% RH (non-condensing)
	Vibration		9.8 m/s ² (1G) less than 10 Hz; 5.9 m/s ² (0.6G) 10 to 60 Hz
	Installation Location		Altitude 1000m or lower above sea level, keep from corrosive gas, liquid and dust
Options		Noise filter, input AC reactor, output AC reactor, cable for remote operator, programming software, dynamic braking resistor, dynamic braking unit; RF filter; remote panel adapter; Ethernet interface; four and eight port RS-485 multi-drop termination boards, replacement keypads, fuse kits and replacement fuses	

DURAPULSE Drives Specifications – Installation

Understanding the installation requirements for your *DURAPULSE* AC drive will help to ensure that it operates within its environmental and electrical limits.

Note: Never use only this catalog for installation instructions or operation of equipment; refer to the user manual, GS3-M.

Environmental Specifications	
Protective Structure ¹	IP20
Ambient Operating Temperature ²	-10 to 40°C (14°F to 104°F) f
Storage Temperature ³	-20 to 60°C (-4°F to 140°F)
Humidity	To 90% (no condensation)
Vibration ⁴	9.8 m/s ² (1g), less than 10 Hz 5.9 m/s ² (0.6g), 10 to 60 Hz
Location	Altitude 1,000 m or less, indoors (no corrosive gases, liquids or dust)
<p>1: Protective structure is based upon EN60529</p> <p>2: The ambient temperature must be in the range of -10° to 40°C. If the range will be up to 50°C, you will need to set the carrier frequency to 2.1 kHz or less and derate the output current to 80% or less.</p> <p>3: The storage temperature refers to the short-term temperature during transport.</p> <p>4: Conforms to the test method specified in JIS C0911 (1984)</p>	

Watt-loss Chart	
GS3 Drive Model	At full load
GS3-21P0	60
GS3-22P0	82
GS3-23P0	130
GS3-25P0	194
GS3-27P5	301
GS3-2010	380
GS3-2015	660
GS3-2020	750
GS3-2025	920
GS3-2030	1300
GS3-2040	1340
GS3-2050	1430
GS3-41P0	70
GS3-42P0	102
GS3-43P0	132
GS3-45P0	176
GS3-47P5	250
GS3-4010	345
GS3-4015	445
GS3-4020	620
GS3-4025	788
GS3-4030	1290
GS3-4040	1420
GS3-4050	1680
GS3-4060	2020
GS3-4075	2910
GS3-4100	3840

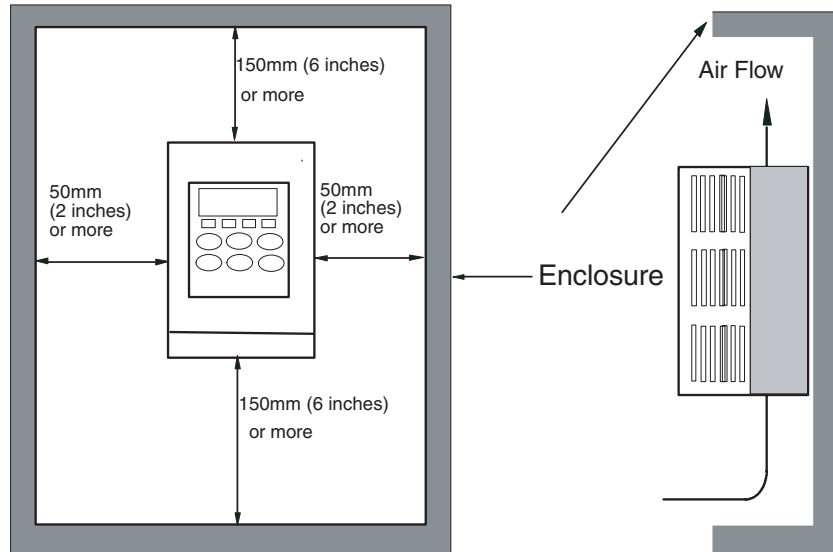

Minimum Clearances and Air Flow



Warning: AC drives generate a large amount of heat which may damage the AC drive. Auxiliary cooling methods are typically required in order not to exceed maximum ambient temperatures.



Warning: Maximum ambient temperatures must not exceed 50°C (122°F), or 40°C (104°F) for models 7.5 hp (5.5 kW) and higher!

DURAPULSE AC Drives Specifications

— Terminals



GS3-4030 shown

Main Circuit Terminals	
Terminal	Description
L1, L2, L3	Input Power
T1, T2, T3	AC Drive Output
B1, B2	Braking Resistor Connection (Under 20HP)
+2, - (negative)	External Dynamic Brake Unit (20HP & Over)
⏏	Ground

Control Circuit Terminals		
Terminal Symbol	Description	Remarks
+24V	DC Voltage Source	(+24V, 20mA), used only for AC drive digital inputs wired for source mode operation
DI1	Digital Input 1	Input Voltage: Internally Supplied (see Warning below) Sink Mode: Low active, $V_{inL} Min = 0V$, $V_{inL} Max = 15V$, $I_{in} Min = 2.1mA$, $I_{in} Max = 7.0mA$ Source Mode: High active, $V_{inH} Min = 8.5V$, $V_{inH} Max = 24V$, $I_{in} Min = 2.1mA$, $I_{in} Max = 7.0mA$ Input response: 12–15 msec Also see "Basic Wiring Diagram" on the next pages.
DI2	Digital Input 2	
DI3	Digital Input 3	
DI4	Digital Input 4	
DI5	Digital Input 5	
DI6	Digital Input 6	
DI7	Digital Input 7	
DI8	Digital Input 8	
DI9	Digital Input 9	
DI10	Digital Input 10	
DI11	Digital Input 11	
DCM	Digital Common	
+10V	Internal Power Supply	+10VDC (10mA maximum load)
AI1	Analog Input	0 to +10 V input only
AI2	Analog Input	0 to 20mA / 4 to 20mA input
AI3	Analog Input	-10 to +10 V input only
ACM	Analog Common	
R10	Relay Output 1 Normally Open	Resistor Load: 240VAC - 5A (N.O.) / 3A (N.C.) 24VDC - 5A (N.O.) / 3A (N.C.) Inductive Load: 240VAC - 1.5A (N.O.) / 0.5A (N.C.) 24VDC - 1.5A (N.O.) / 0.5A (N.C.) See P 3.01 to P 3.03
R1C	Relay Output 1 Normally Closed	
R1	Relay Output 1 Common	
DO1	Photocoupled digital output	Maximum 48VDC, 50mA
DO2	Photocoupled digital output	
DO3	Photocoupled digital output	
DOC	Digital Output Common	
AO	Analog Output	0 to +10 V 2mA Output
FO	Digital Frequency Output	Square wave pulse train output



WARNING: Do NOT connect external voltage sources to the digital inputs. Permanent damage may result.



NOTE: Use TWISTED-SHIELDED, TWISTED-PAIR OR SHIELDED-LEAD WIRES FOR THE CONTROL SIGNAL WIRING. IT IS RECOMMENDED TO RUN ALL SIGNAL WIRING IN A SEPARATE STEEL CONDUIT. THE SHIELD WIRE SHOULD ONLY BE CONNECTED AT THE AC DRIVE. DO NOT CONNECT SHIELD WIRE ON BOTH ENDS.

DURAPULSE AC Drives – Basic Wiring Diagram

Power Wiring Diagram - drives under 20 hp

Note: Users MUST connect wiring according to the circuit diagram shown below. (Refer to user manual GS3-M for additional specific wiring information.)

Note: Please refer to the following catalog pages in the Drives section* of our catalog for explanations and information regarding feedback cards, line reactors, braking resistors, EMI and RF filters, and fuses: 47, 49, 68, 73, 79, 80.

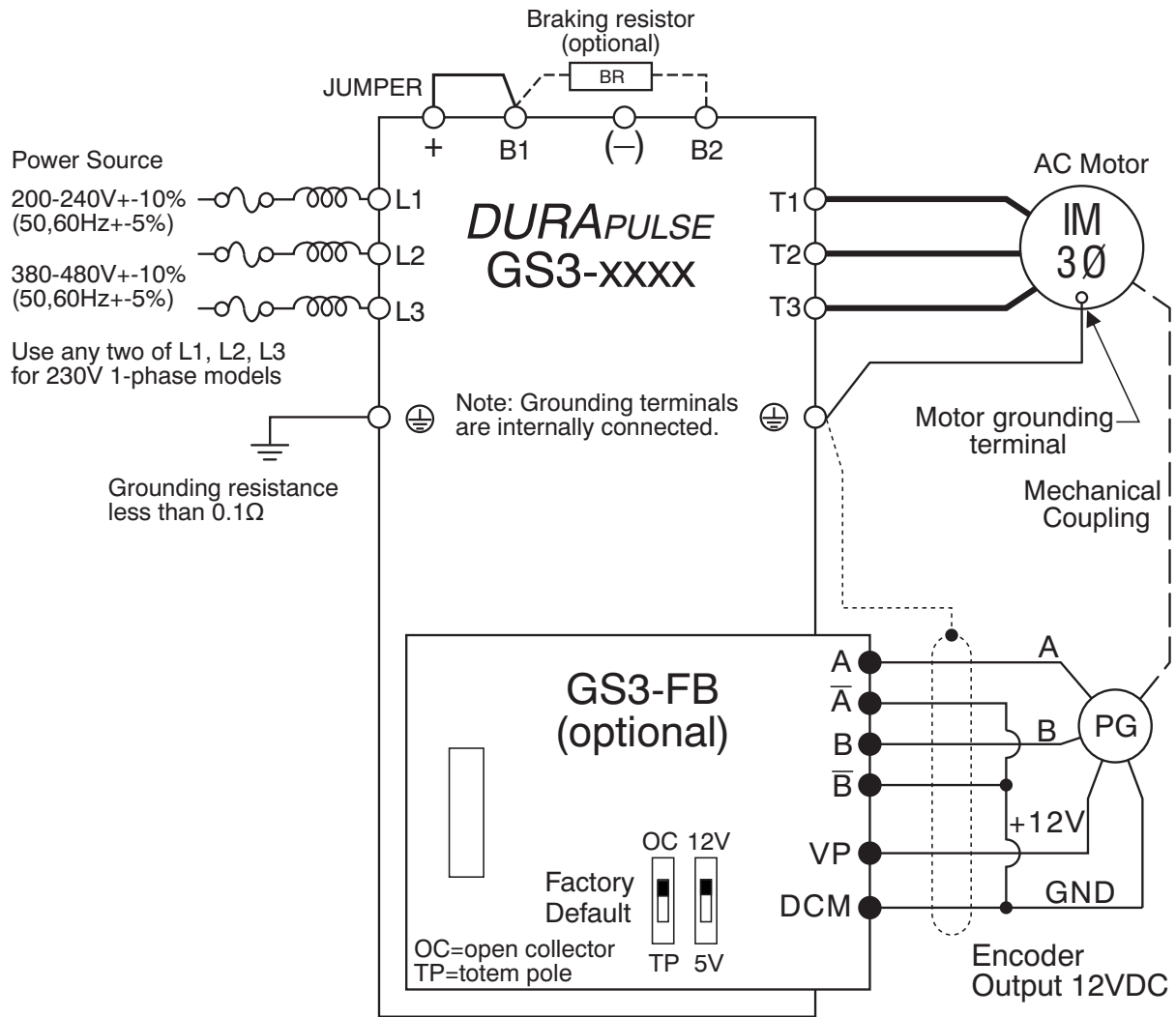

○ Main circuit (power) terminals ● Control circuit terminal ⊕ Shielded leads



WARNING: Do not plug a modem or telephone into the GS3/DURAPULSE RJ-12 Serial Comm Port, or permanent damage may result. Terminals 2 and 5 should not be used as a power source for your communication connection.

*The Drives section is in Book 2 of current version of our catalog, or you can download PDF of section here.

DURAPULSE AC Drives – Basic Wiring Diagram

Power Wiring Diagram – 20 to 30 hp (230 VAC) & 20 to 60 hp (460 VAC)

Note: Users MUST connect wiring according to the circuit diagram shown below. (Refer to user manual GS3-M for additional specific wiring information.)

Note: Please refer to the following catalog pages in the Drives section* of our catalog for explanations and information regarding feedback cards, line reactors, braking units and resistors, EMI and RF filters, and fuses: 47, 49, 66, 68, 73, 79, 80.

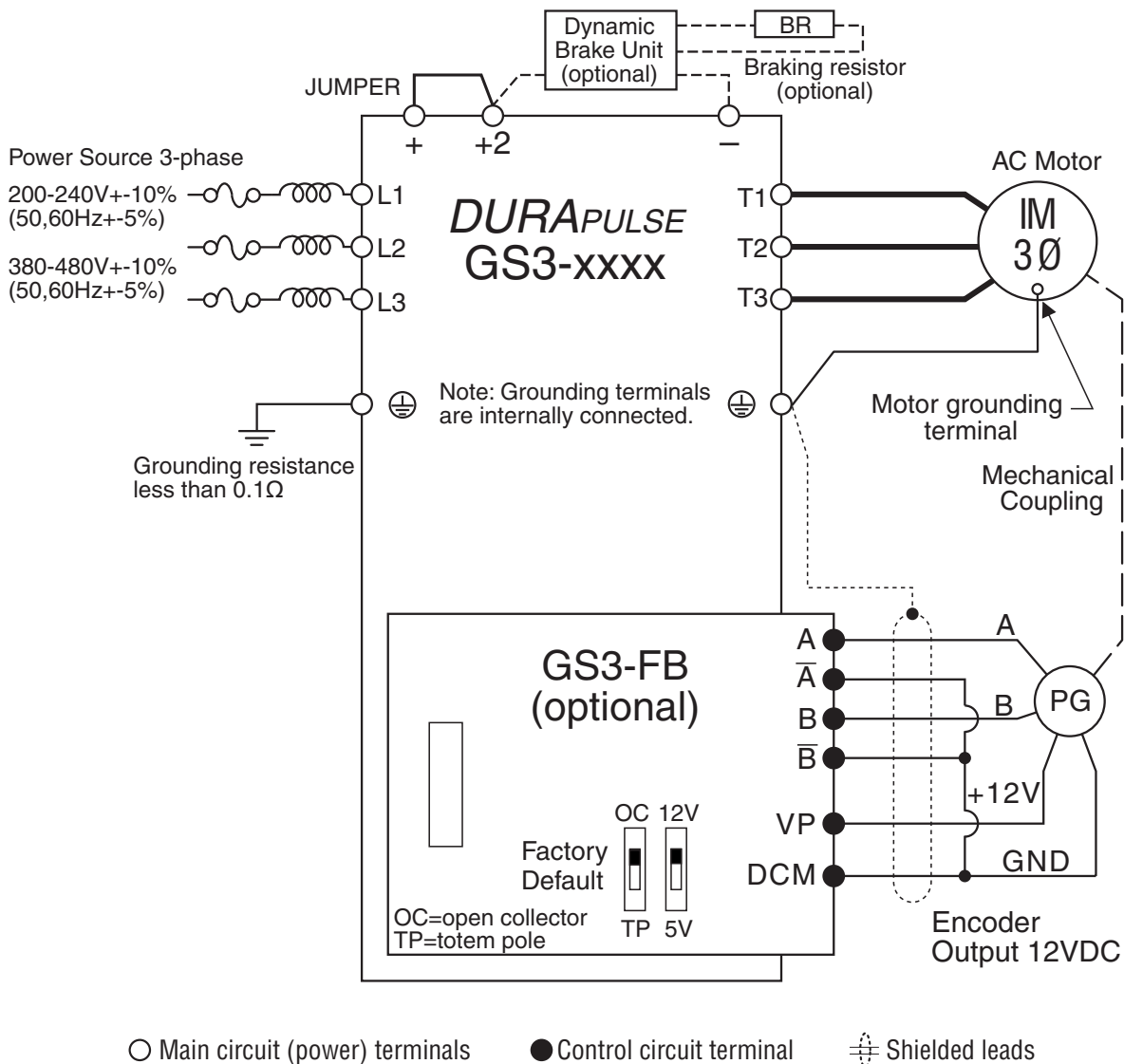

WARNING: Do not plug a modem or telephone into the GS3/DURAPULSE RJ-12 Serial Comm Port, or permanent damage may result. Terminals 2 and 5 should not be used as a power source for your communication connection.

*The Drives section is in Book 2 of current version of our catalog, or you can download PDF of section here.

DURAPULSE AC Drives – Basic Wiring Diagram

Power Wiring Diagram - 40 to 50 hp (230 VAC) & 75 to 100 hp (460 VAC)

Note: Users MUST connect wiring according to the circuit diagram shown below. (Refer to user manual GS3-M for additional specific wiring information.)

Note: Please refer to the following catalog pages in the Drives section* of our catalog for explanations and information regarding feedback cards, line reactors, braking units and resistors, EMI and RF filters, and fuses: 47, 49, 66, 68, 73, 79, 80.

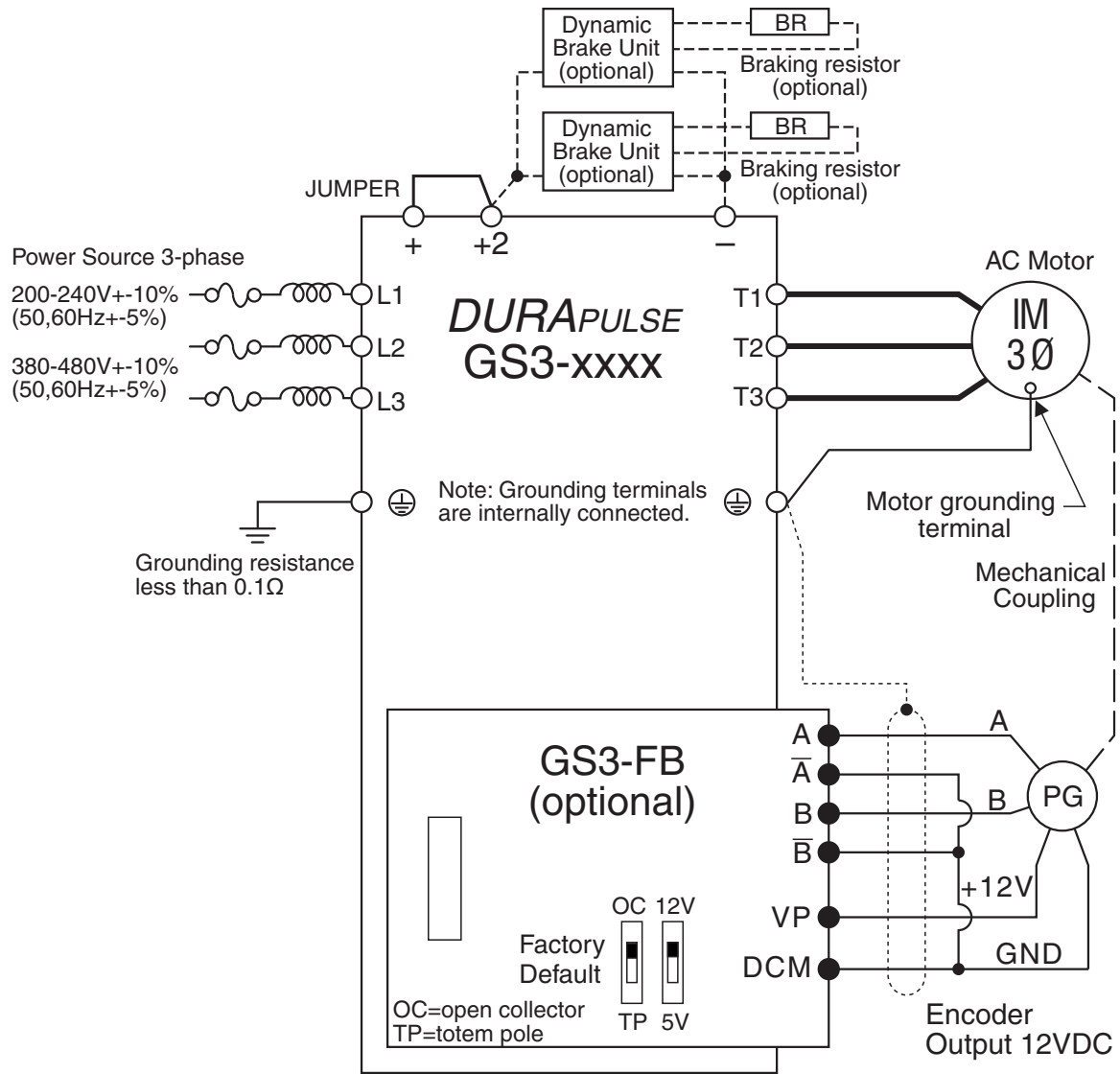

○ Main circuit (power) terminals ● Control circuit terminal ⊕ Shielded leads



WARNING: Do not plug a modem or telephone into the GS3/DURAPULSE RJ-12 Serial Comm Port, or permanent damage may result. Terminals 2 and 5 should not be used as a power source for your communication connection.

*The Drives section is in Book 2 of current version of our catalog, or you can download PDF of section here.

DURAPULSE AC Drives – Control Wiring Diagram – DI Connection to Sinking Outputs

Control Wiring Diagram - Digital Input Connections to Sinking Output Devices



NOTE: USERS MUST CONNECT WIRING ACCORDING TO THE CIRCUIT DIAGRAM SHOWN BELOW.

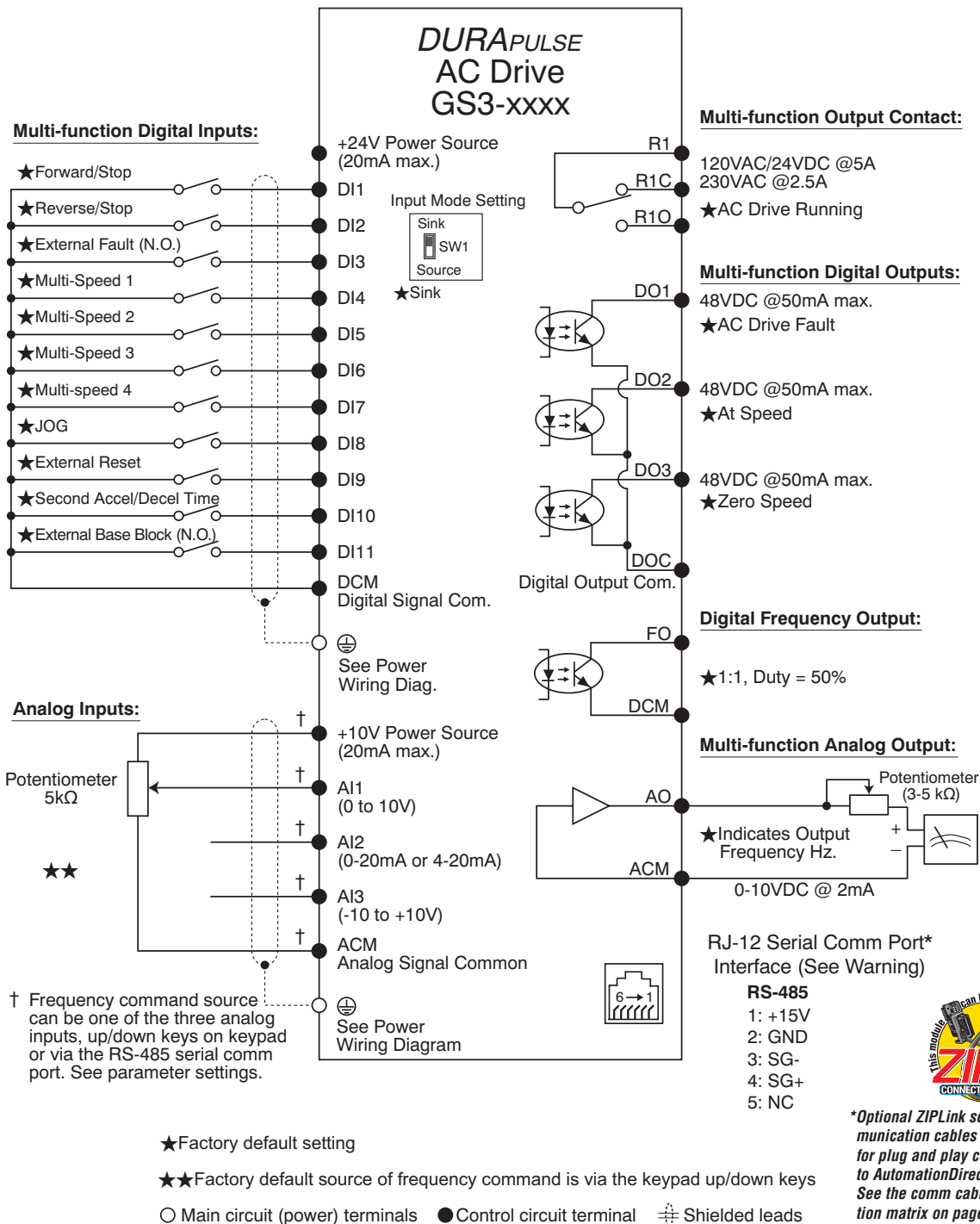

**Optional ZIPLink serial communication cables available for plug and play connectivity to AutomationDirect PLCs. See the comm cable selection matrix on page 92.*



WARNING: Do not plug a modem or telephone into the DURAPULSE RJ-12 Serial Comm Port, or permanent damage may result.

DURAPULSE AC Drives – Control Wiring Diagram – DI Connections to Sourcing Outputs

Control Wiring Diagram - Digital Input Connections to Sourcing Output Devices



NOTE: USERS MUST CONNECT WIRING ACCORDING TO THE CIRCUIT DIAGRAM SHOWN BELOW.

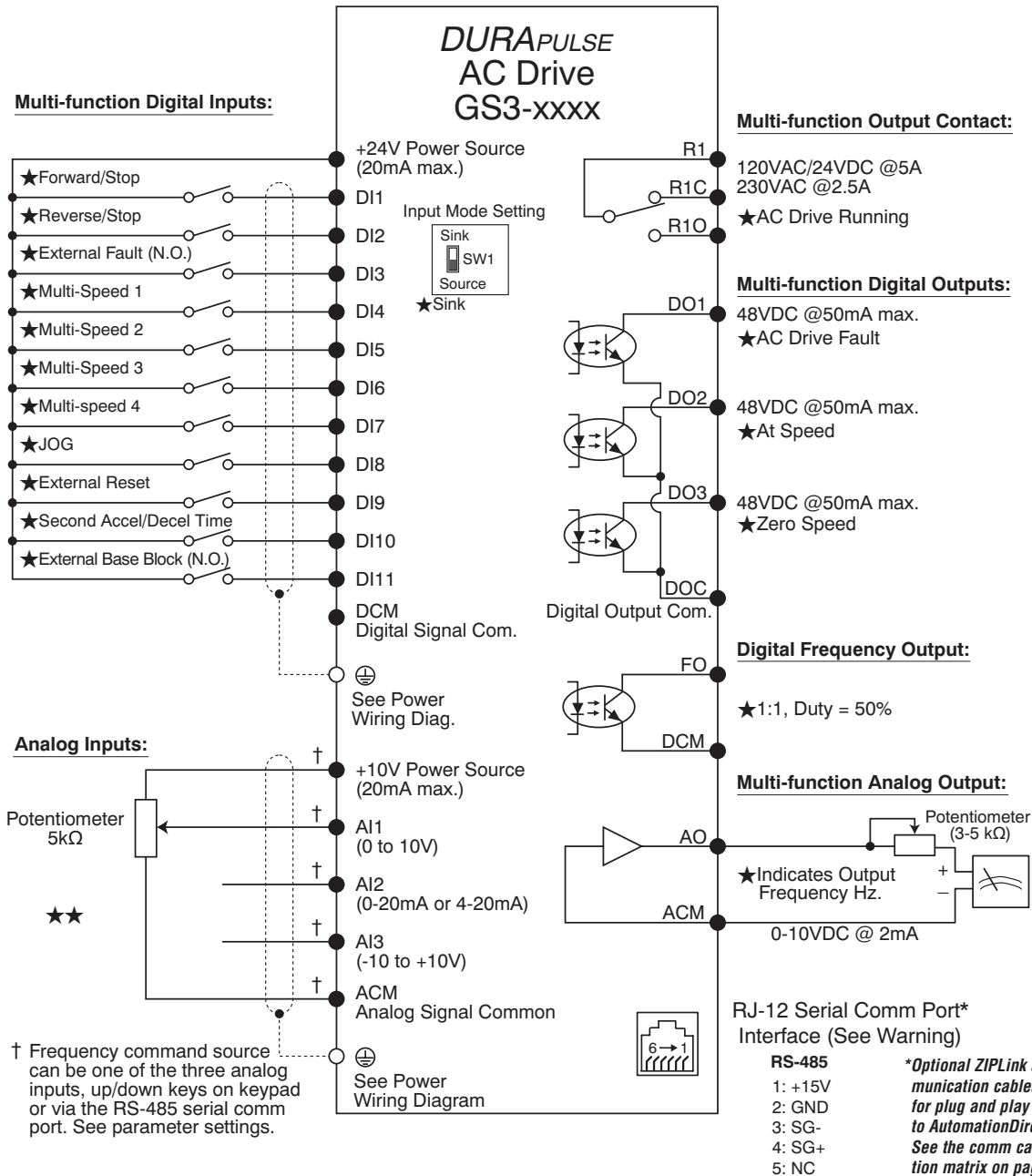

★ Factory default setting

★★ Factory default source of frequency command is via the keypad up/down keys

○ Main circuit (power) terminals ● Control circuit terminal ⏏ Shielded leads



WARNING: Do not plug a modem or telephone into the DURAPULSE RJ-12 Serial Comm Port, or permanent damage may result.



DURAPULSE AC Drives — Dimensions

GS3-21P0, GS3-22P0, GS3-41P0, GS3-42P0

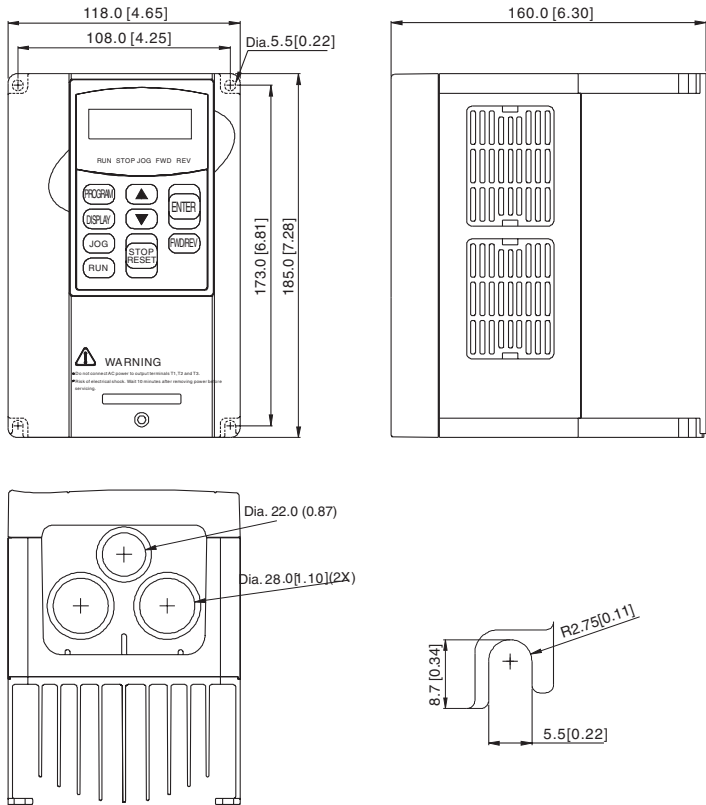

GS3-43P0

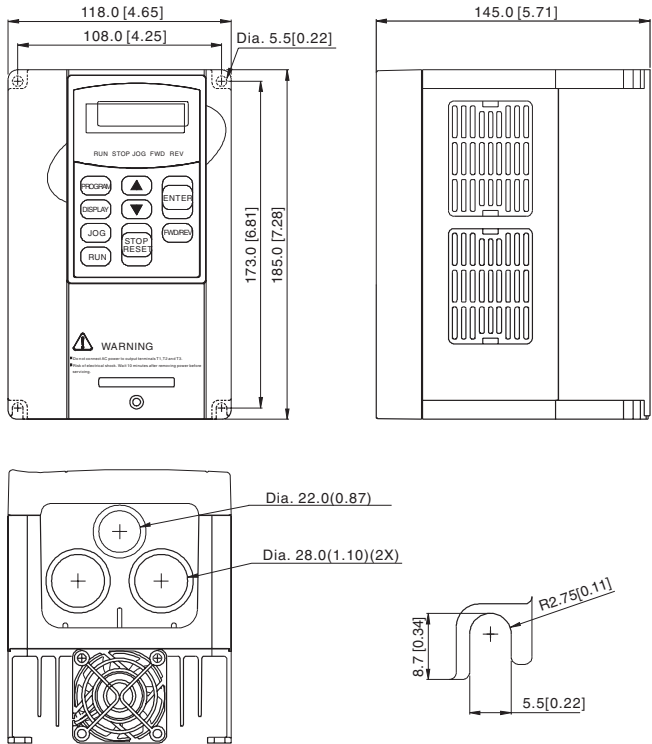

unit: mm(in)

DURAPULSE AC Drives — Dimensions

GS3-23P0, GS3-25P0, GS3-45P0

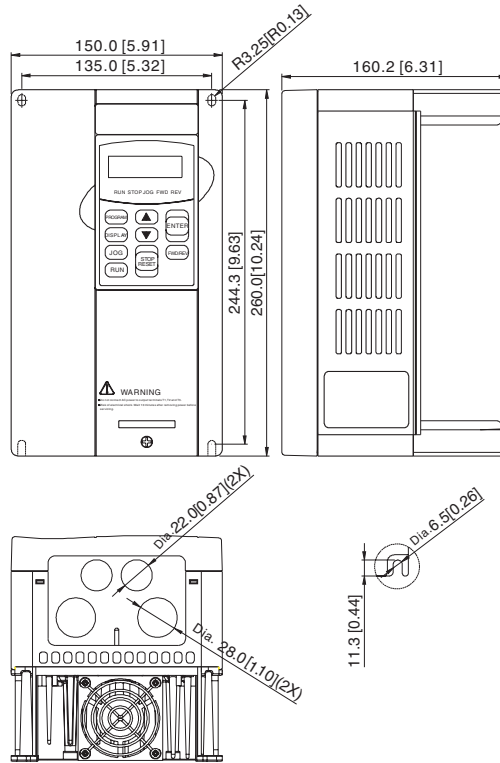

GS3-27P5, GS3-2010, GS3-2015, GS3-47P5, GS3-4010, GS3-4015

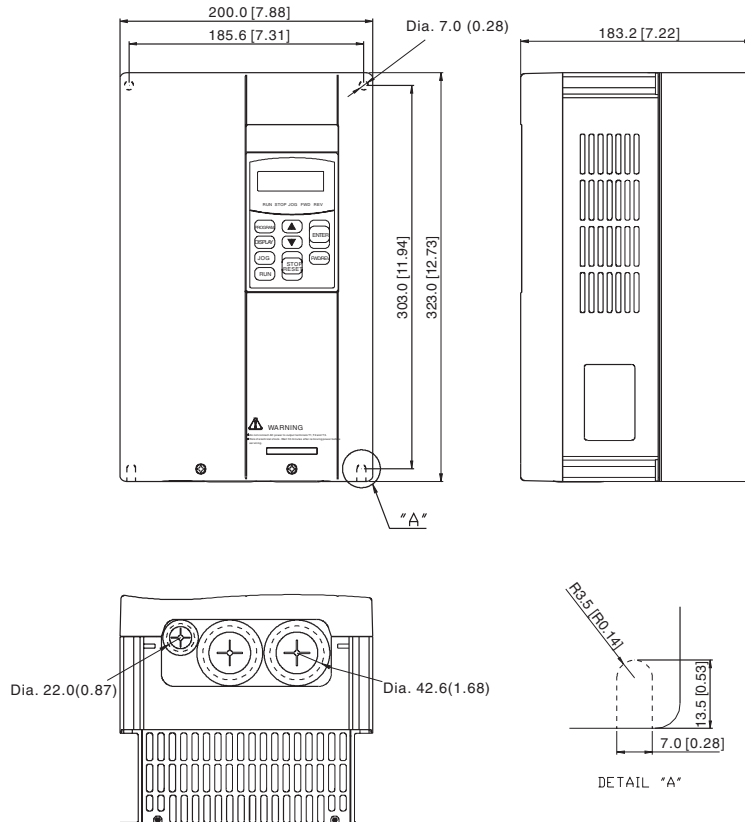

unit: mm(in)

DURAPULSE AC Drives — Dimensions

GS3-2020, GS3-2025, GS3-2030, GS3-4020, GS3-4025, GS3-4030

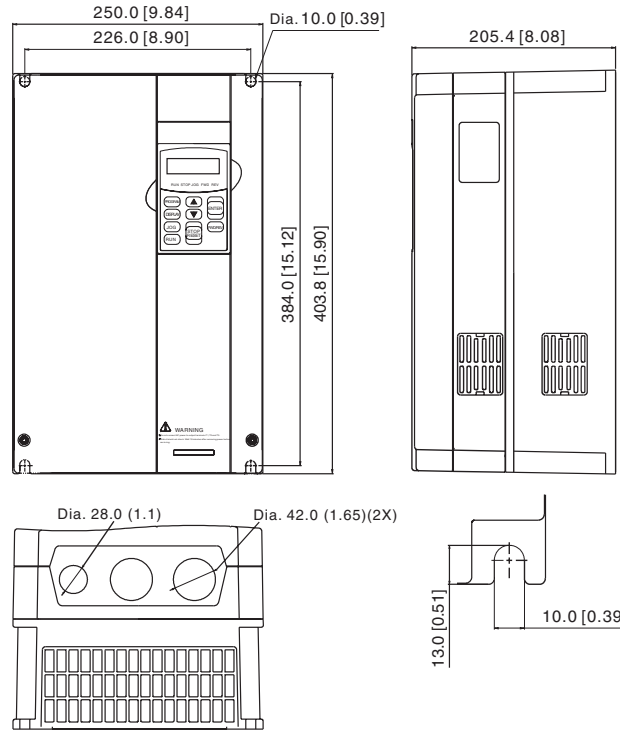

GS3-2040, GS3-2050, GS3-4040, GS3-4050, GS3-4060

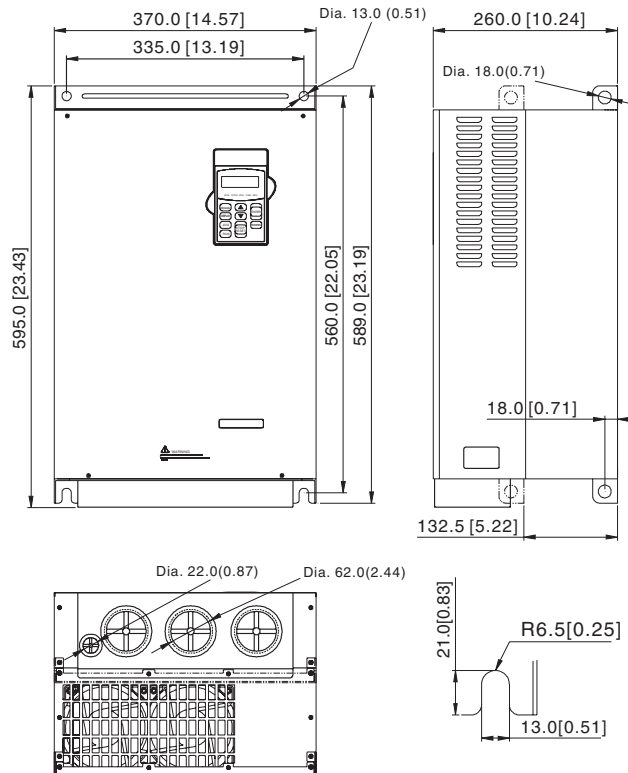

unit: mm(in)

DURAPULSE AC Drives — Dimensions

GS3-4075, GS3-4100

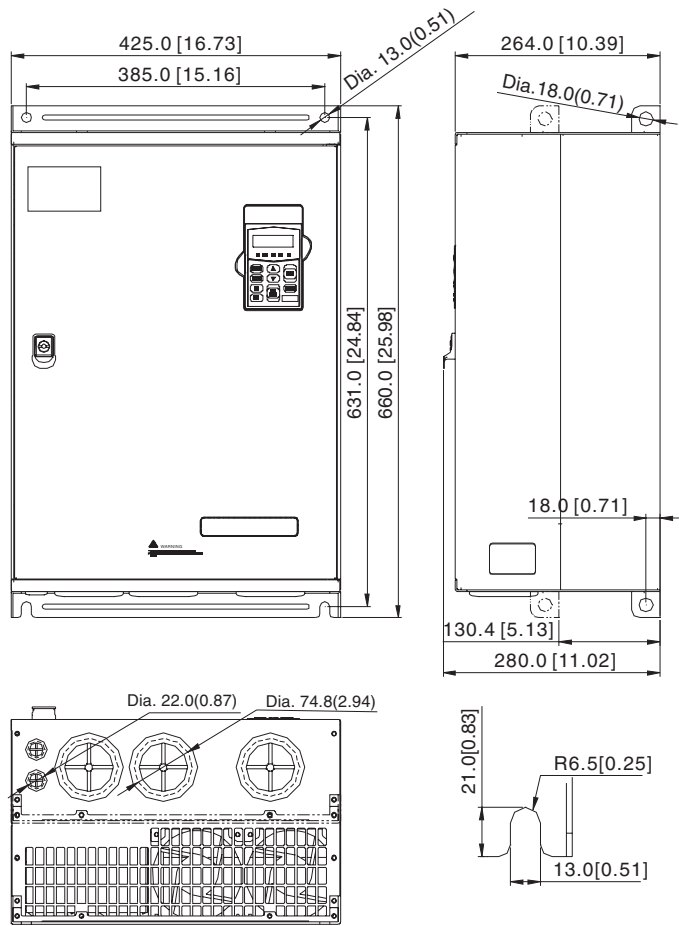

unit: mm(in)

GS/DURAPULSE Accessories – Overview

Accessories – Part numbering system

Note: With the exception of the EMI filters, RF filters, and LR series line reactors, each accessory part number begins with GS, followed by the AC Drive rating, and then the relevant accessory code. Following the accessory code, you will find a description code when applicable. The diagram at right shows the accessory part numbering system.

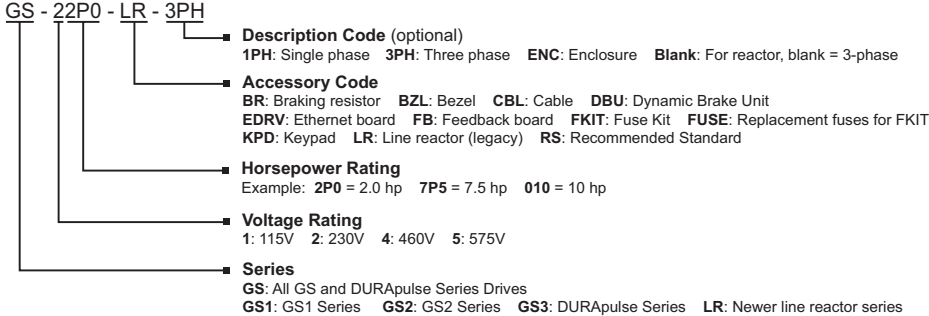

Under 20hp

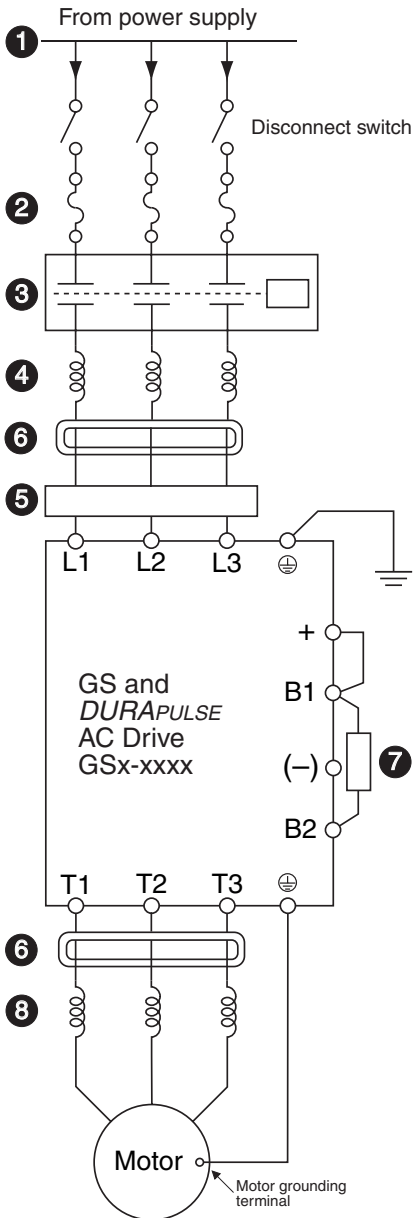

GS/DURAPULSE Accessories – Overview

20hp & Over (DURAPULSE only)

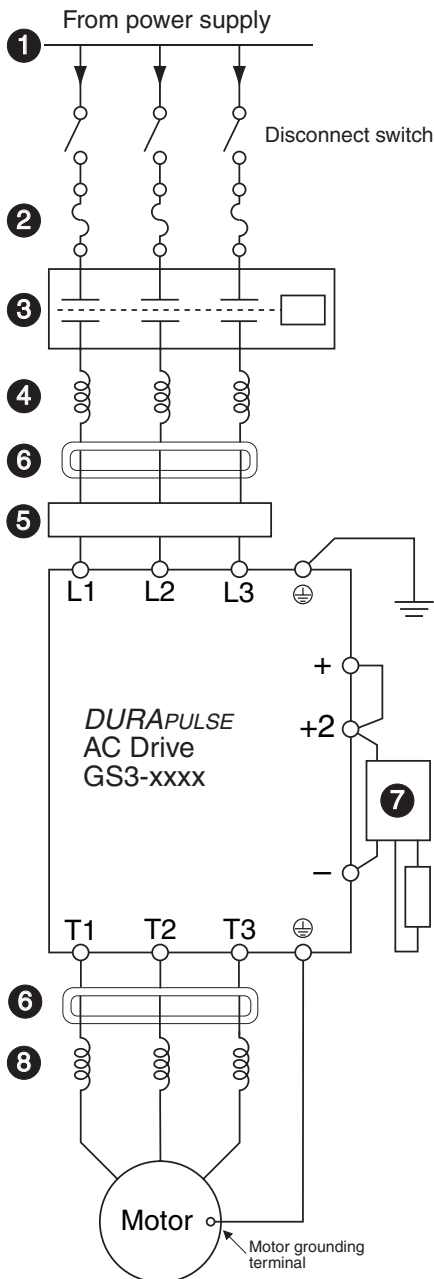

1 Power Supply

Please follow the specific power supply requirements shown in Chapter 1 of the *DURAPULSE* AC Drives User Manual.

2 Fuses

(Please refer to catalog page 80 in the Drives section* of our catalog.)

Input fuses protect the AC drive from excessive input current due to line surges, short circuits, and ground faults. They are recommended for all installations and may be required for UL-listed installations.

3 Contactor (Optional)

(Refer to the Motor Controls section.)

Do not use a contactor or disconnect switch for run/stop control of the AC drive and motor. This will reduce the operating life cycle of the AC drive. Cycling a power circuit switching device while the AC drive is in run mode should be done only in emergency situations.

4 Input Line Reactor (Optional)

(Please refer to catalog page 49 in the Drives section* of our catalog.)

Input line reactors protect the AC drive from transient overvoltage conditions, typically caused by utility capacitor switching. The input line reactor also reduces the harmonics associated with AC drives. Input line reactors are recommended for all installations.

5 EMI filter (Optional)

(Please refer to catalog page 73 in the Drives section* of our catalog.)

Input EMI filters reduce electromagnetic interference or noise on the input side of the AC drive. They are required for CE compliance and recommended for installations prone to or sensitive to electromagnetic interference.

6 RF filter (Optional)

(Please refer to catalog page 79 in the Drives section* of our catalog.)

RF filters reduce the radio frequency interference or noise on the input or output side of the inverter.

7 Braking Unit & Braking Resistor (Optional)

(Please refer to catalog page 66 in the Drives section* of our catalog.)

Dynamic braking allows the AC drive to produce additional braking (stopping) torque. AC drives can typically produce between 15% & 20% braking torque without the addition of any external components. The addition of optional braking may be required for applications that require rapid deceleration or high inertia loads.

8 Output Line Reactor (Optional)

(Please refer to catalog page 49 in the Drives section* of our catalog.)

Output line reactors protect the motor insulation against AC drive short circuits and IGBT reflective wave damage, and also “smooth” the motor current waveform, allowing the motor to run cooler. They are **recommended** for operating “non-inverter-duty” motors and when the length of wiring between the AC drive and motor exceeds 75 feet.

**The Drives section is in Book 2 of current version of our catalog, or you can download PDF of section here.*

GS/DURAPULSE Accessories – Feedback Card

Feedback Card for DURAPULSE AC Drives		
Part Number	Price	Drive Model
GS3-FB	\$58.00	GS3-xxxx
The GS3-FB feedback card is for use only with DURApulse AC drives.		

Description

The GS3-FB card is used to add another layer of precision control to the already precise control algorithm utilized in the DURAPULSE drive series. This added control is activated by selecting control modes V/Hz closed loop control or sensorless vector with external feedback. The feedback mechanism uses pulses generated by an external encoder or pulse generator. Unlike other feedback types, the GS3-FB accommodates the four most common encoder signal types: output voltage, open collector, line driver, and complimentary.

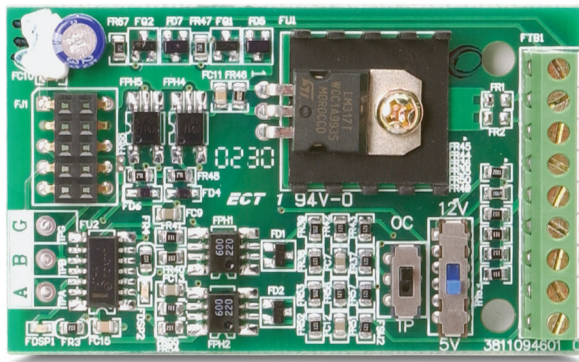

Closed Loop Diagram

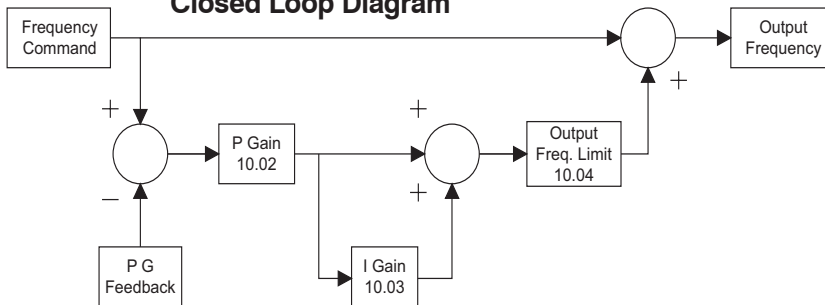

Types of Encoders		SW1 and SW2 switches	
		5V	12V
Output Voltage			
Open collector			
Line driver			
Complimentary			

GS/DURAPULSE Accessories – Feedback Card

Wiring Diagrams

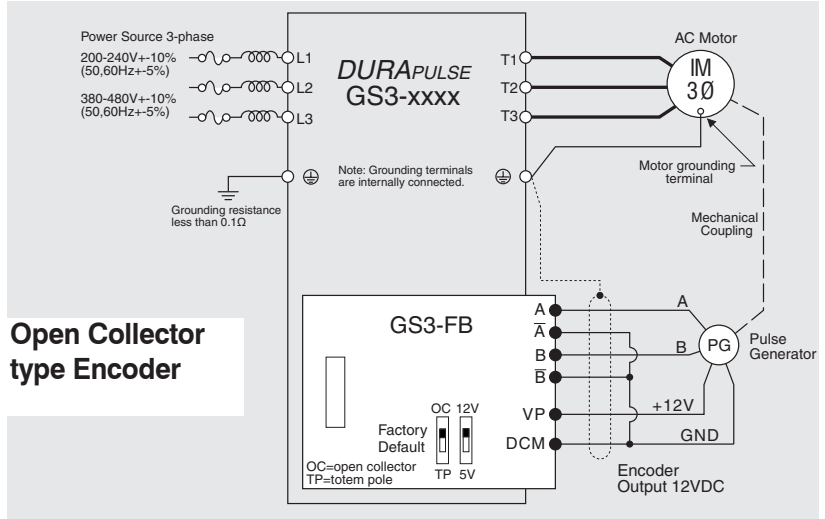

Terminal Symbols	Description
VP	Power source of GS3-FB (SW1 can be switched to 12V or 5V) Output Voltage: (+12VDC ±5% 200mA) or (+5VDC ±2% 400mA)
DCM	Power source (VP) and input signal (A, B) common
A, NOT A, B, NOT B	Input signal from Encoder. Input type is selected by SW2; Maximum 500kp/sec
A/O, B/O	GS3-FB output signal for use with RPM Meter. (Open Collector) Maximum DC24V 100mA
COM	GS3-FB output signal (A/O, B/O) common

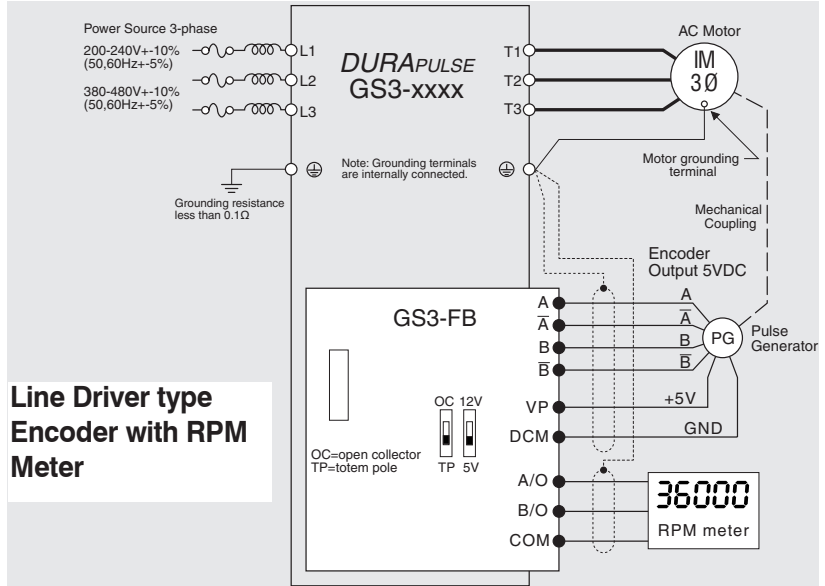

Control Terminals Block Designations

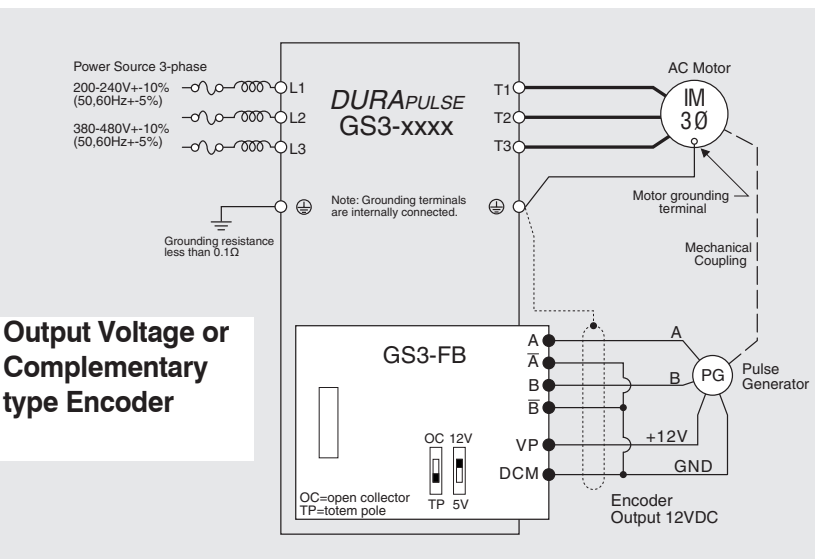
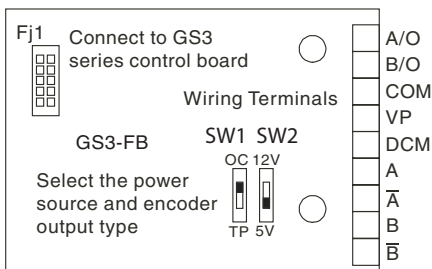

GS/DURAPULSE Drives Accessories

– Line Reactors

LR Series Line Reactors

Input line reactors protect the AC drive from transient overvoltage conditions typically caused by utility capacitor switching. Input line reactors also reduce the harmonics associated with AC drives, and are recommended for all installations.

Output line (load) reactors protect the motor insulation against AC drive short circuits and IGBT reflective wave damage, and also allow the motor to run cooler by “smoothing” the motor current waveform. They are recommended for operating “non-inverter-duty” motors, and for any motors where the length of wiring between the AC drive and motor exceeds 75 feet.

Features:

- Universal mounting feet with multiple mounting slots; can replace most reactors using existing mounting holes.
- 10-year warranty

Agency Approvals:

- cUL_{US} listed (E197592)
- CE marked
- RoHS

Line Reactors – LR Series									
Part Number	Price	Rated Amps	Impedance	Inductance	Watt Loss	System Voltage	Phase – Use (1)	GS Drive Model	Drive hp
LR-10P2-1PH (2)	\$59.00	5.8	3%	1.58 mH	8.0	120	1 – In 1 – In	GS1-10P2 GS2-10P2	0.25 0.25
LR-10P5-1PH (2)	\$70.00	9.8		0.93 mH	11.7		1 – In 1 – In	GS1-10P5 GS2-10P5	0.5 0.5
LR-11P0-1PH (2)	\$87.00	16		0.57 mH	17.4		1 – In	GS2-11P0	1
LR-20P5-1PH (2)	\$59.00	4.9		3.74 mH	11.2	240	1 – In 1 – In 1 – In	GS1-20P2 GS1-20P5 GS2-20P5	0.25 0.5 0.5
LR-20P5	\$57.00	2.4		4.2 mH	7	208/240	3 – Out 3 – Out 3 – Out 3 – Out 3 – I/O 3 – I/O 3 – I/O	GS1-10P2 GS1-10P5 GS2-10P2 GS2-10P5 GS1-20P2 GS1-20P5 GS2-20P5	0.25 0.5 0.25 0.5 0.25 0.5 0.5
LR-21P0-1PH (2)	\$62.00	8		2.29 mH	15.9	240	1 – In 1 – In 1 – In	GS1-21P0 GS2-21P0 GS3-21P0	1 1 1
LR-21P0	\$63.00	4.6		2.46 mH	11	208/240	3 – I/O 3 – I/O 3 – I/O 3 – Out	GS1-21P0 GS2-21P0 GS3-21P0 GS2-11P0	1 1 1 1
LR-22P0-1PH (2)	\$71.00	12		1.53 mH	24.3	240	1 – In 1 – In 1 – In	GS1-22P0 GS2-22P0 GS3-22P0	2 2 2
LR-22P0	\$68.00	7.5		1.35 mH	21	208/240	3 – I/O 3 – I/O 3 – I/O	GS1-22P0 GS2-22P0 GS3-22P0	2 2 2
LR-23P0-1PH (2)	\$90.00	17		1.08 mH	27.3	240	1 – In 1 – In	GS2-23P0 GS3-23P0	3 3
LR-23P0	\$75.00	10.6		0.97 mH	38	208/240	3 – I/O 3 – I/O	GS2-23P0 GS3-23P0	3 3
LR-25P0	\$99.00	16.7		0.626 mH	48		3 – I/O 3 – I/O	GS3-25P0 GS2-25P0	5 5
LR-27P5	\$106.00	24.2		0.434 mH	65		3 – I/O 3 – I/O	GS2-27P5 GS3-27P5	7.5 7.5

1) Use (side of drive): In = input only; Out = output only; I/O = input or output.
 2) Single-phase line reactors should NOT be installed on the output side of AC drives.

*** TABLE CONTINUED NEXT PAGE ***

GS/DURAPULSE Drives Accessories

– Line Reactors

*** TABLE CONTINUED FROM PREVIOUS PAGE ***

Line Reactors – LR Series									
Part Number	Price	Rated Amps	Impedance	Inductance	Watt Loss	System Voltage	Phase – Use ⁽¹⁾	GS Drive Model	Drive hp
LR-2010	\$117.00	30.8		0.342 mH	96	208/240		GS3-2010	10
LR-2015	\$147.00	46.2		0.22 mH	64			GS3-2015	15
LR-2020	\$157.00	59.4		0.172 mH	85			GS3-2020	20
LR-2025	\$238.00	74.8		0.138 mH	94			GS3-2025	25
LR-2030	\$253.00	88		0.116 mH	135			GS3-2030	30
LR-2040	\$356.00	114		0.0886 mH	149			GS3-2040	40
LR-2050	\$415.00	143		0.0699 mH	154			GS3-2050	50
LR-41P0	\$62.00	2.1	3%	8.927 mH	10.4	480	3 – I/O	GS2-41P0 GS3-41P0	1 1
LR-42P0	\$65.00	3.4		5.79 mH	19			GS2-42P0 GS3-42P0	2 2
LR-43P0	\$72.00	4.8		4.27 mH	23			GS2-43P0 GS3-43P0	3 3
LR-45P0	\$75.00	7.6		2.77 mH	49			GS2-45P0 GS3-45P0	5 5
LR-47P5	\$84.00	11		1.68 mH	40			GS2-47P5 GS3-47P5	7.5 7.5
LR-4010	\$106.00	14		1.29 mH	64			GS2-4010 GS3-4010	10 10
LR-4015	\$123.00	21		0.912 mH	65			GS3-4015	15
LR-4020	\$135.00	27		0.694 mH	79			GS3-4020	20
LR-4025	\$143.00	34		0.569 mH	96			GS3-4025	25
LR-4030	\$179.00	40		0.469 mH	105			GS3-4030	30
LR-4040	\$198.00	52		0.387 mH	114			GS3-4040	40
LR-4050	\$232.00	65		0.295 mH	114			GS3-4050	50
LR-4060	\$239.00	77		0.227 mH	169			GS3-4060	60
LR-4075	\$362.00	96		0.196 mH	193			GS3-4075	75
LR-4100	\$410.00	124		0.152 mH	225			GS3-4100	100
LR-4125	\$497.00	156		0.117 mH	254			–	125
LR-4150	\$576.00	180	0.103 mH	299	150				
LR-4200	\$767.00	240	0.0839 mH	280	200				
LR-4250	\$826.00	302	0.0654 mH	337	250				
LR-4300	\$843.00	361	0.0565 mH	381	300				
LR-51P0	\$71.00	1.7		15.9 mH	12	575/600		GS2-51P0	1
LR-52P0	\$75.00	2.7		9.29 mH	22			GS2-52P0	2
LR-53P0	\$78.00	3.9		6.74 mH	23.3			GS2-53P0	3
LR-55P0	\$81.00	6.1		4.51 mH	34.7			GS2-55P0	5
LR-5010	\$107.00	11		2.47 mH	43.8			GS2-57P5	7.5

1) Use (side of drive): In = input only; Out = output only; I/O = input or output.

GS/DURAPULSE Drives Accessories

- Line Reactors

Line Reactors – LR Series – Additional Specifications						
Part Number	Product Weight	Wire Range	Terminal Torque	Temperature Range		Environment
				Operating	Storage	
LR-10P2-1PH	2.6 lb [1.2 kg]	#12-#18 AWG	10 lb-in	-40 – 104 °F [-40 – 40 °C]	-40 – 149 °F [-40 – 65 °C]	NEMA: open IP00 no corrosive gases
LR-10P5-1PH	2.7 lb [1.2 kg]	#12-#18 AWG	10 lb-in			
LR-11P0-1PH	4.2 lb [1.9 kg]	#12-#18 AWG	20 lb-in			
LR-20P5-1PH	2.8 lb [1.3 kg]	#12-#18 AWG	10 lb-in			
LR-20P5	4.0 lb [1.8 kg]	#12-#18 AWG	10 lb-in			
LR-21P0-1PH	2.8 lb [1.3 kg]	#12-#18 AWG	10 lb-in			
LR-21P0	4.0 lb [1.8 kg]	#12-#18 AWG	10 lb-in			
LR-22P0-1PH	4.3 lb [2.0 kg]	#12-#18 AWG	20 lb-in			
LR-22P0	4.0 lb [1.8 kg]	#12-#18 AWG	10 lb-in			
LR-23P0-1PH	4.3 lb [2.0 kg]	#12-#18 AWG	20 lb-in			
LR-23P0	4.0 lb [1.8 kg]	#12-#18 AWG	10 lb-in			
LR-25P0	8.0 lb [3.6 kg]	#18-#4 AWG	20 lb-in			
LR-27P5	8.0 lb [3.6 kg]	#18-#4 AWG	20 lb-in			
LR-2010	12 lb [5.4 kg]	#18-#4 AWG	20 lb-in			
LR-2015	12 lb [5.4 kg]	#18-#4 AWG	20 lb-in			
LR-2020	12 lb [5.4 kg]	#18-#4 AWG	20 lb-in			
LR-2025	15 lb [6.8 kg]	#18-#4 AWG	#18-#16 AWG: 25 lb-in #14-#6 AWG: 30 lb-in #4 AWG: 35 lb-in			
LR-2030	33 lb [15 kg]	2/0 – #6AWG (AL or CU)	120			
LR-2040	33 lb [15 kg]	2/0 – #6AWG (AL or CU)	120			
LR-2050	36 lb [16 kg]	250kcmil – #6AWG (AL or CU)	275			
LR-41P0	4.0 lb [1.8 kg]	#12-#18 AWG	10 lb-in			
LR-42P0	4.0 lb [1.8 kg]	#12-#18 AWG	10 lb-in			
LR-43P0	4.0 lb [1.8 kg]	#12-#18 AWG	10 lb-in			
LR-45P0	4.0 lb [1.8 kg]	#12-#18 AWG	10 lb-in			
LR-47P5	4.0 lb [1.8 kg]	#12-#18 AWG	10 lb-in			
LR-4010	4.0 lb [1.8 kg]	#12-#18 AWG	10 lb-in			
LR-4015	8.0 lb [3.6 kg]	#18-#4 AWG	20 lb-in			
LR-4020	8.0 lb [3.6 kg]	#18-#4 AWG	20 lb-in			
LR-4025	10 lb [4.5 kg]	#18-#4 AWG	20 lb-in			
LR-4030	10 lb [4.5 kg]	#18-#4 AWG	20 lb-in			
LR-4040	15 lb [6.8 kg]	#18-#4 AWG	20 lb-in			
LR-4050	25 lb [11 kg]	#22-#4 AWG	#22-#16 AWG: 25 lb-in #14-#6 AWG: 30 lb-in #4 AWG: 35 lb-in			
LR-4060						
LR-4075	33 lb [15 kg]	2/0 – #6AWG (AL or CU)	120 lb-in			
LR-4100	46 lb [21 kg]	250kcmil – #6AWG (AL or CU)	275 lb-in			
LR-4125	46 lb [21 kg]	250kcmil – #6AWG (AL or CU)	275 lb-in			
LR-4150	46 lb [21 kg]	250kcmil – #6AWG (AL or CU)	275 lb-in			
LR-4200	74 lb [34 kg]	(1) 600kcmil – #4 AWG (2) 250kcmil – 1/0	500 lb-in			
LR-4250	74 lb [34 kg]	(2)* 350kcmil – #4 AWG (AL or CU)	275 lb-in			
LR-4300	74 lb [34 kg]	(2)* 350kcmil – #4 AWG (AL or CU)	275 lb-in			
LR-51P0	4.0 lb [1.8 kg]	#12-#18 AWG	10 lb-in			
LR-52P0						
LR-53P0						
LR-55P0						
LR-5010						

* LR-4250 & LR-4300 have dual-connector lugs, and will require multiple conductors per phase of the appropriate size to fit the lugs.

GS/DURAPULSE Drives Accessories

- Line Reactors

Line Reactor Part Number Cross Reference

Line Reactors – LR Series – Part Number Cross Reference					
<i>AutomationDirect LR Series</i>	<i>AutomationDirect GS Series (legacy)</i>	<i>AB-1321</i>	<i>Hammond</i>	<i>MTE-RL</i>	<i>MTE-RLW</i>
LR-10P2-1PH	GS-10P2-LR	NA	NA	NA	NA
LR-10P5-1PH	GS-10P5-LR	NA	NA	NA	NA
LR-11P0-1PH	GS-11P0-LR	NA	NA	NA	NA
LR-20P5-1PH	GS-20P5-LR-1PH	NA	NA	NA	NA
LR-20P5	GS-20P5-LR-3PH	NA	NA	NA	NA
LR-21P0-1PH	GS-21P0-LR-1PH	NA	NA	NA	NA
LR-21P0	GS-21P0-LR-3PH	1321-3R4-A	RM0004N30	RL-00401	RLW-04P801
LR-22P0-1PH	GS-22P0-LR-1PH	NA	NA	NA	NA
LR-22P0	GS-22P0-LR-3PH	1321-3R8-A	RM0008N15	RL-00801	RLW-07P601
LR-23P0-1PH	GS-23P0-LR-1PH	NA	NA	NA	NA
LR-23P0	GS-23P0-LR-3PH	1321-3R12-A	RM0012N13	RL-01201	RLW-001101
LR-25P0	GS-25P0-LR	1321-3R18-A	RM0018P80	RL-01801	RLW-001401
LR-27P5	GS-27P5-LR	1321-3R25-A	RM0025P50	RL-02501	RLW-002101
LR-2010	GS-2010-LR	1321-3R35-A	RM0035P40	RL-03501	RLW-003501
LR-2015	GS-2015-LR	1321-3R45-A	RM0045P30	RL-04501	RLW-004601
LR-2020	GS-2020-LR	1321-3R55-A	RM0055P25	RL-05501	RLW-005501
LR-2025	GS-2025-LR	1321-3R80-A	RM0080P20	RL-08001	RLW-008301
LR-2030	GS-2030-LR	1321-3R100-A	RM0080P20	RL-10001	RLW-010401
LR-2040	GS-2040-LR	1321-3R130-A	RM0130P10	RL-13001	RLW-013001
LR-2050	GS-2050-LR	1321-3R130-A	RM0130P10	RL-13001	RLW-013001
LR-41P0	GS-41P0-LR	1321-3R1-B	RM0002M12	RL-00201	RLW-02P103
LR-42P0	GS-42P0-LR	1321-3R4-B	RM0004N65	RL-00402	RLW-04P805
LR-43P0	GS-43P0-LR	1321-3R4-B	RM0008N50	RL-00402	RLW-04P805
LR-45P0	GS-45P0-LR	1321-3R8-B	RM0008N30	RL-00802	RLW-07P603
LR-47P5	GS-47P5-LR	1321-3R12-B	RM0012N25	RL-01202	RLW-001103
LR-4010	GS-4010-LR	1321-3R18-B	RM0018N15	RL-01802	RLW-001403
LR-4015	GS-4015-LR	1321-3R25-B	RM0025N12	RL-02502	RLW-002103
LR-4020	GS-4020-LR	1321-3R35-B	RM0035P80	RL-03502	RLW-003503
LR-4025	GS-4025-LR	1321-3R35-B	RM0035P80	RL-03502	RLW-003503
LR-4030	GS-4030-LR	1321-3R45-B	RM0045P70	RL-04502	RLW-004603
LR-4040	GS-4040-LR	1321-3R55-B	RM0055P50	RL-05502	RLW-005503
LR-4050	GS-4050-LR	1321-3R80-B	RM0080P40	RL-08002	RLW-008305
LR-4060	GS-4060-LR	1321-3R80-B	RM0080P40	RL-08002	RLW-008305
LR-4075	GS-4075-LR	1321-3R100-B	RM0110P30	RL-10002	RLW-010403
LR-4100	GS-4100-LR	1321-3R130-B	RM0130P20	RL-13002	RLW-013003
LR-51P0	GS-51P0-LR	1321-3R2-B	RM0002M20	RL-00202	RLW-02P105
LR-52P0	GS-52P0-LR	1321-3R4-C	RM0004M12	RL-00403	RLW-04P806
LR-53P0	N/A	1321-3R4-C	RM0004N91	RL-00403	RLW-04P806
LR-55P0	N/A	1321-3R8-C	RM0008N50	RL-00803	RLW-07P605
LR-5010	N/A	1321-3R12-B	RM0012N25	RL-01202	RLW-001103
LR-4125	N/A	1321-3R160-B	RM0160P15	RL-16002	RLW-016003
LR-4150	N/A	1321-3R200-B	RM0200P11	RL-20002B14	RLW-020003
LR-4200	N/A	1321-3RB250-B	RM0250U90	RL-25002B14	RLW-025003
LR-4250	N/A	1321-3RB320-B	RM0320U75	RL-32002B14	RLW-032203
LR-4300	N/A	1321-3RB400-B	RM0400U61	RL-40002B14	RLW-041403

GS/DURAPULSE Drives Accessories – Line Reactors

Input side of the drive

When installed on the input side of the AC drive, line reactors will reduce line notching, and limit current and voltage spikes and surges from the incoming line. The line reactor will also reduce harmonic distortion from the drive onto the line. Units are installed in front of the AC drive as shown.

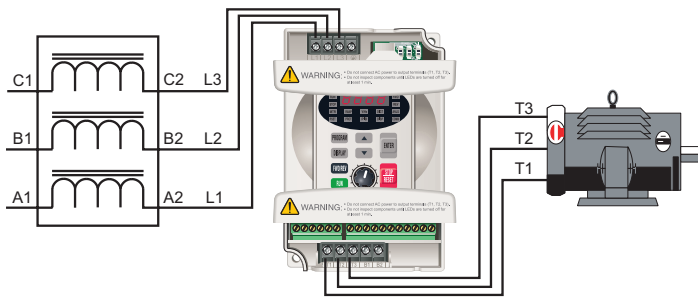

Note: Single phase line reactors should NOT be installed on the output of the AC drive. Use only three-phase reactors on drive outputs, and only for three-phase motors.

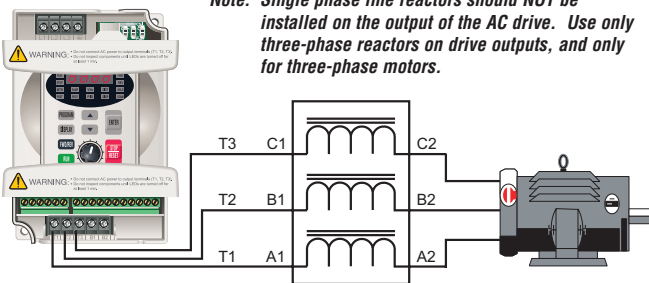

Output side of the drive

When installed on the output side of the drive, line reactors protect the drive from short circuits at the load. Voltage and current waveforms from the drive are enhanced, reducing motor overheating and noise emissions.

Note: If installing a line reactor on the output side of the drive, especially with motor lead lengths in excess of 75 feet, lower the drive PWM output carrier frequency to 4kHz in order to protect the line reactor from excess heating and possible damage.

Multiple drives

Individual line reactors are recommended when installing multiple drives on the same power line. Individual line reactors eliminate crosstalk between multiple drives and provide isolated protection for each drive for its own specific load.

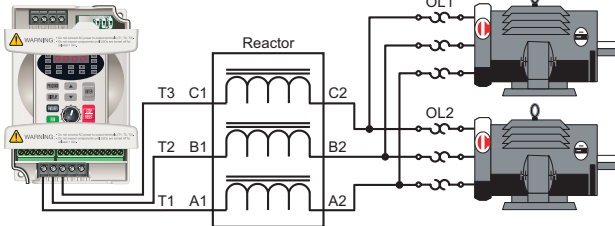
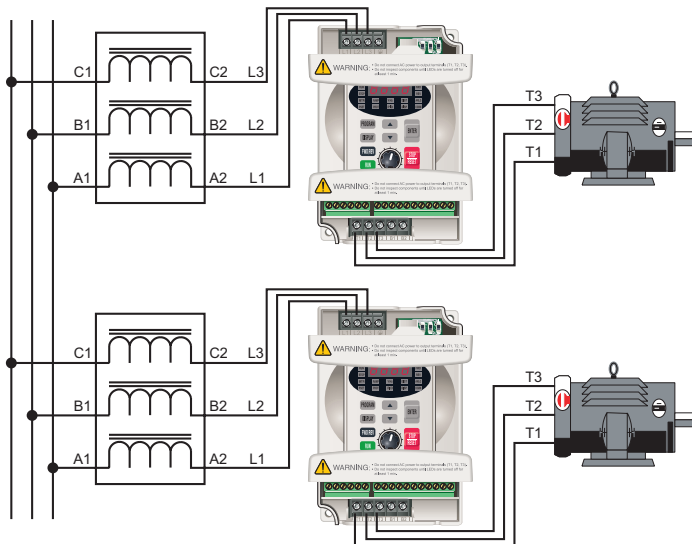

Multiple motors

A single reactor can be used for multiple motors on the same drive, if the motors operate simultaneously. Size the reactor based upon the total horsepower of all the motors. Select a reactor with a current rating greater than the sum of the motor full-load currents. Overload relays are recommended for use in multi-motor applications.

Note: A single reactor should be used with multiple motors only when the motors will always operate simultaneously.

Single phase applications

Some of the line reactors are listed for use with single-phase input power. Make sure that terminals B1 and B2, if present, are properly insulated before any connections are made.



WARNING: Please ensure that terminals B1 and B2 are properly insulated before making any connections to single-phase power.

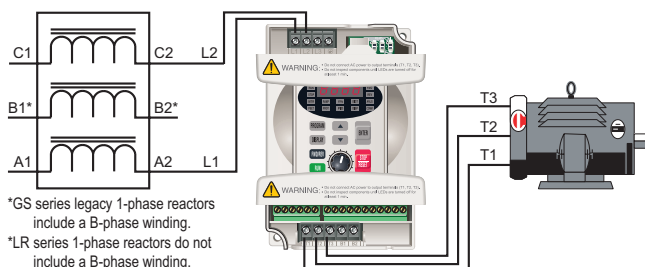

*GS series legacy 1-phase reactors include a B-phase winding.
*LR series 1-phase reactors do not include a B-phase winding.

GS/DURAPULSE Drives Accessories

– Line Reactors

Line Reactor Dimensions

LR-10P2-1PH, LR-10P5-1PH, LR-20P5-1PH, LR-21P0-1PH

LR series reactors have universal mounting feet with multiple mounting slots, and they can replace most reactors using the existing mounting holes. Use four bolts to mount the reactors to the mounting panel.

(Units = inches [mm])

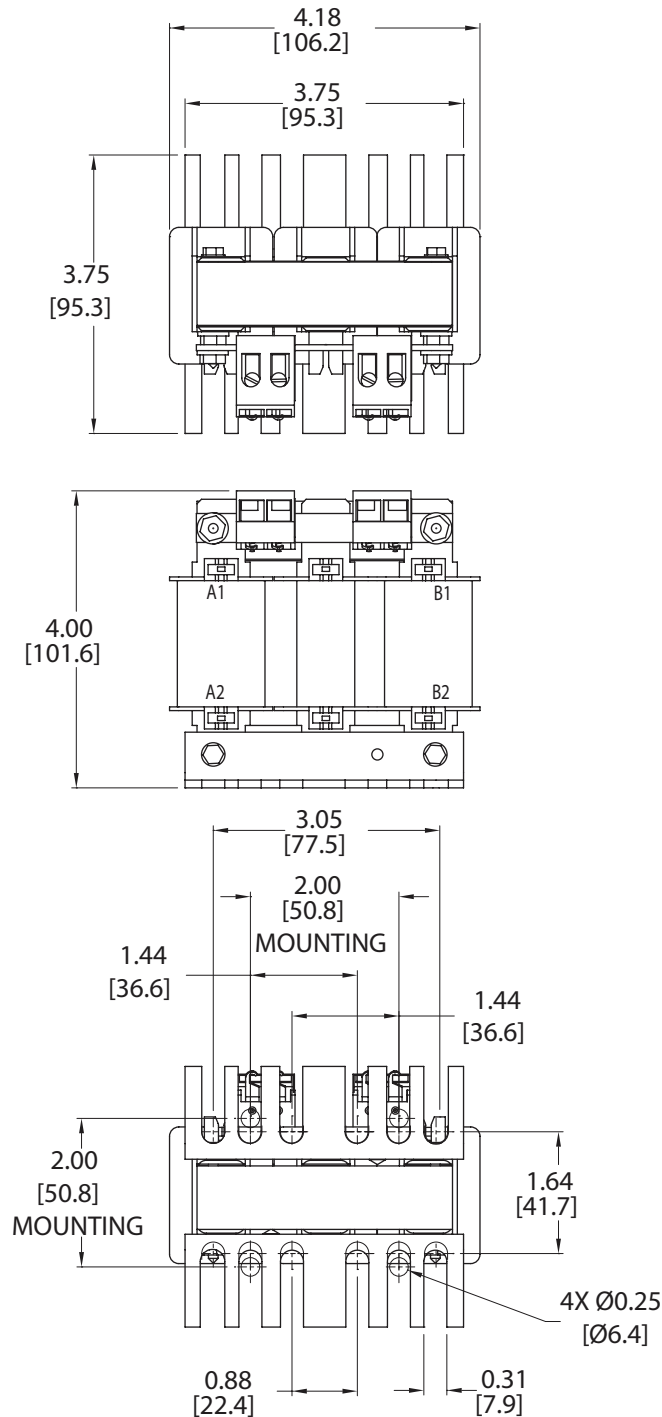

GS/DURAPULSE Drives Accessories

– Line Reactors

Line Reactor Dimensions

LR-11P0-1PH, LR-22P0-1PH, LR-23P0-1PH

LR series reactors have universal mounting feet with multiple mounting slots, and they can replace most reactors using the existing mounting holes. Use four bolts to mount the reactors to the mounting panel.

(Units = inches [mm])

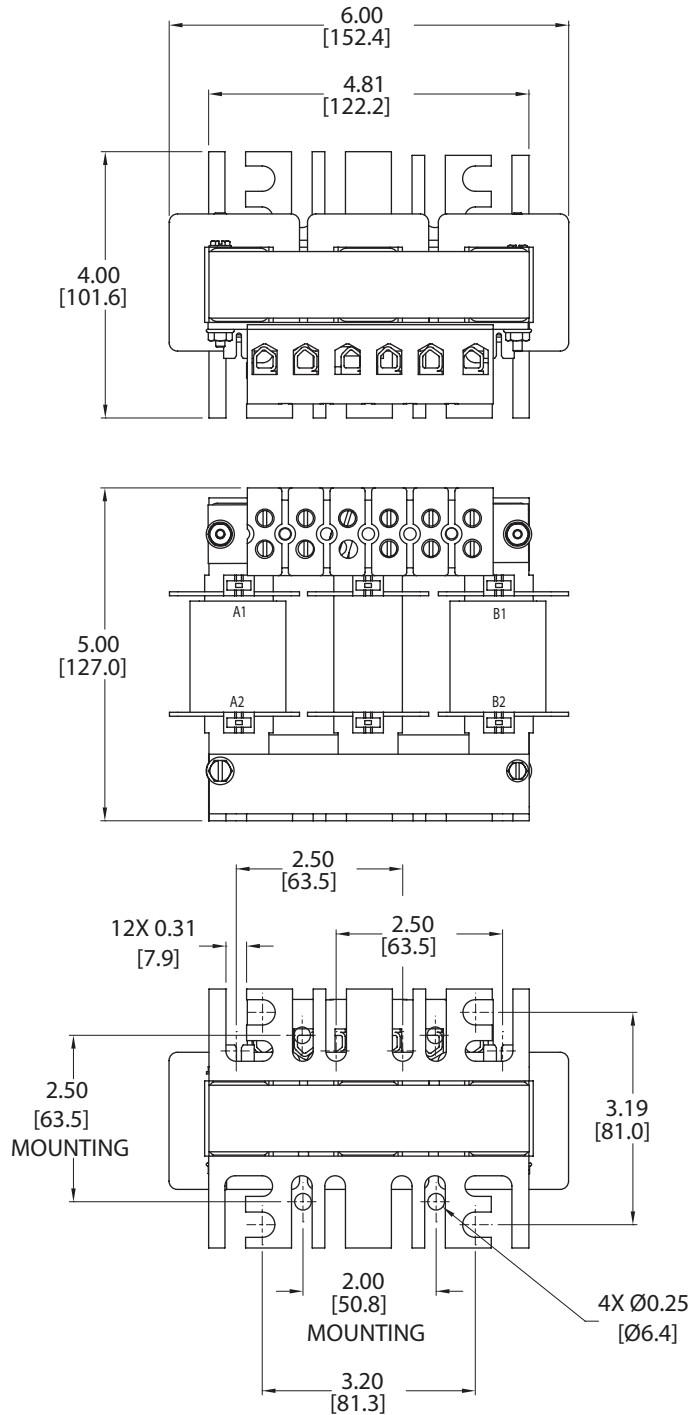

GS/DURAPULSE Drives Accessories

– Line Reactors

Line Reactor Dimensions

LR-20P5, LR-21P0, LR-22P0, LR-23P0, LR-41P0, LR-42P0, LR-43P0, LR-45P0, LR-47P5, LR-4010, LR-51P0, LR-52P0, LR-53P0, LR-55P0, LR-5010

LR series reactors have universal mounting feet with multiple mounting slots, and they can replace most reactors using the existing mounting holes. Use four bolts to mount the reactors to the mounting panel.

(Units = inches [mm])

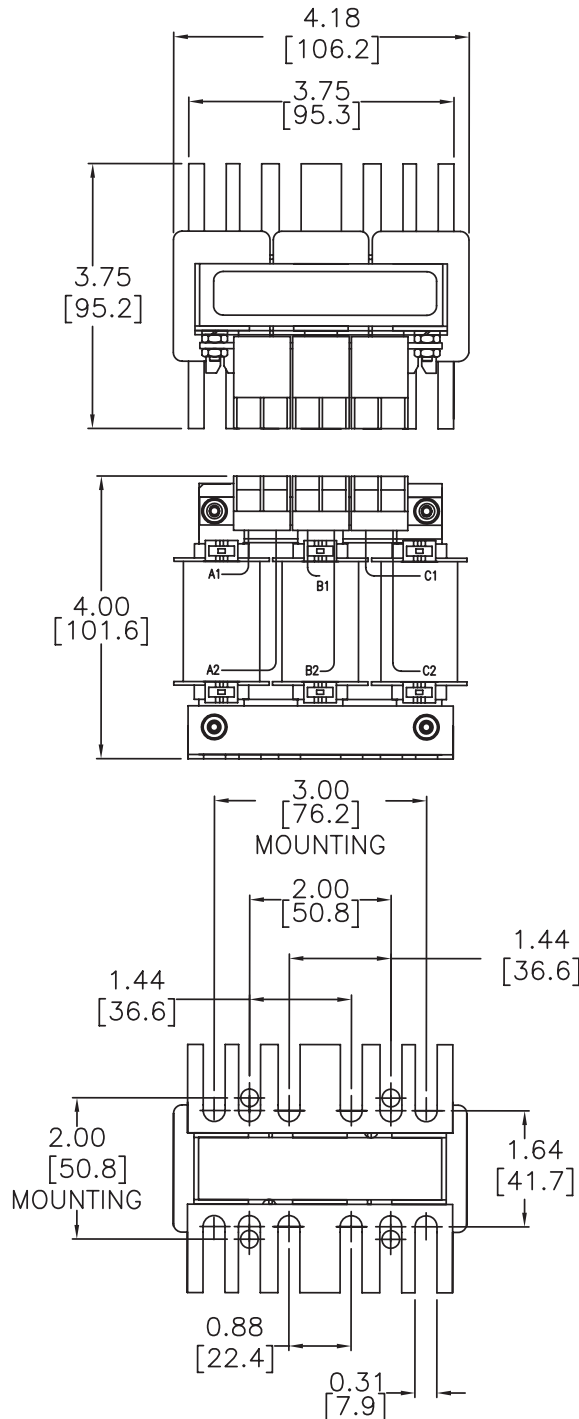

GS/DURAPULSE Drives Accessories

– Line Reactors

Line Reactor Dimensions

LR-25P0, LR-27P5, LR-4015, LR-4020

LR series reactors have universal mounting feet with multiple mounting slots, and they can replace most reactors using the existing mounting holes. Use four bolts to mount the reactors to the mounting panel.

(Units = inches [mm])

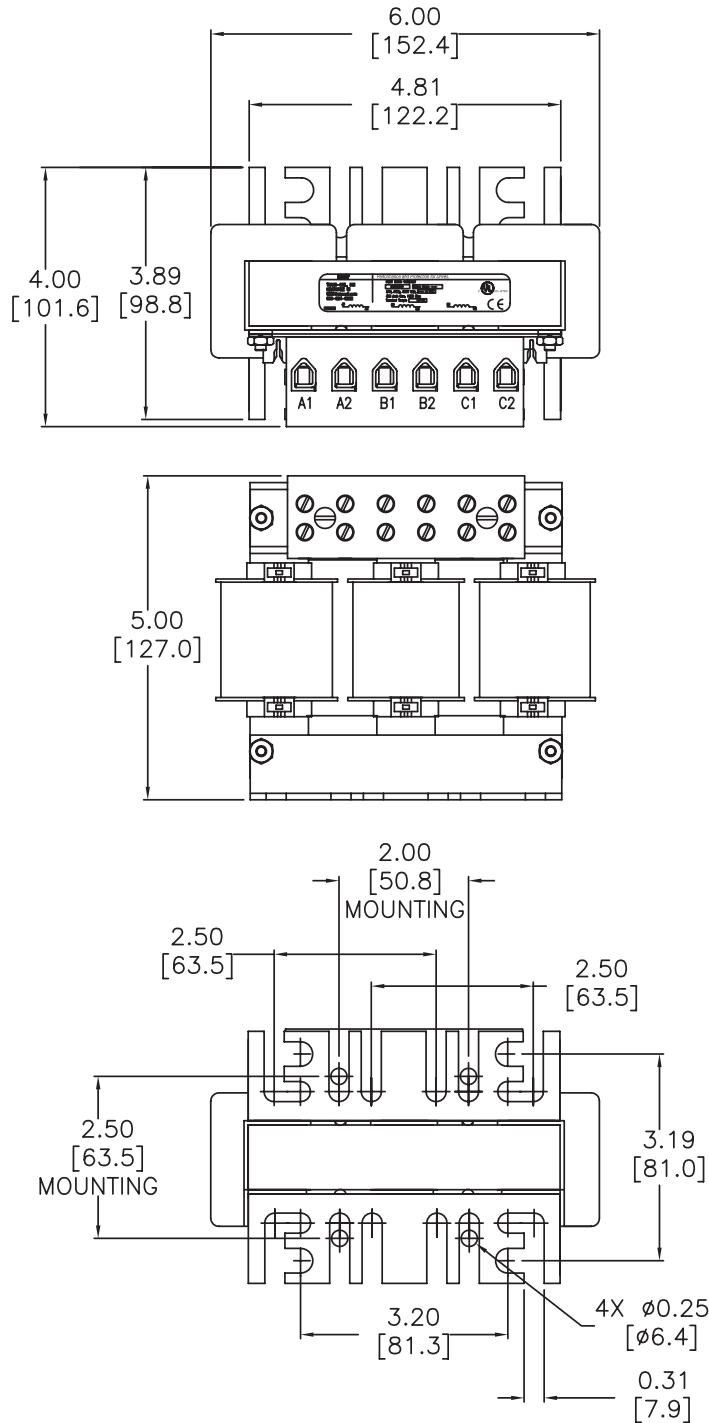

GS/DURAPULSE Drives Accessories

- Line Reactors

Line Reactor Dimensions

LR-2010, LR-2015, LR-2020, LR-4025, LR-4030

LR series reactors have universal mounting feet with multiple mounting slots, and they can replace most reactors using the existing mounting holes. Use four bolts to mount the reactors to the mounting panel.

(Units = inches [mm])

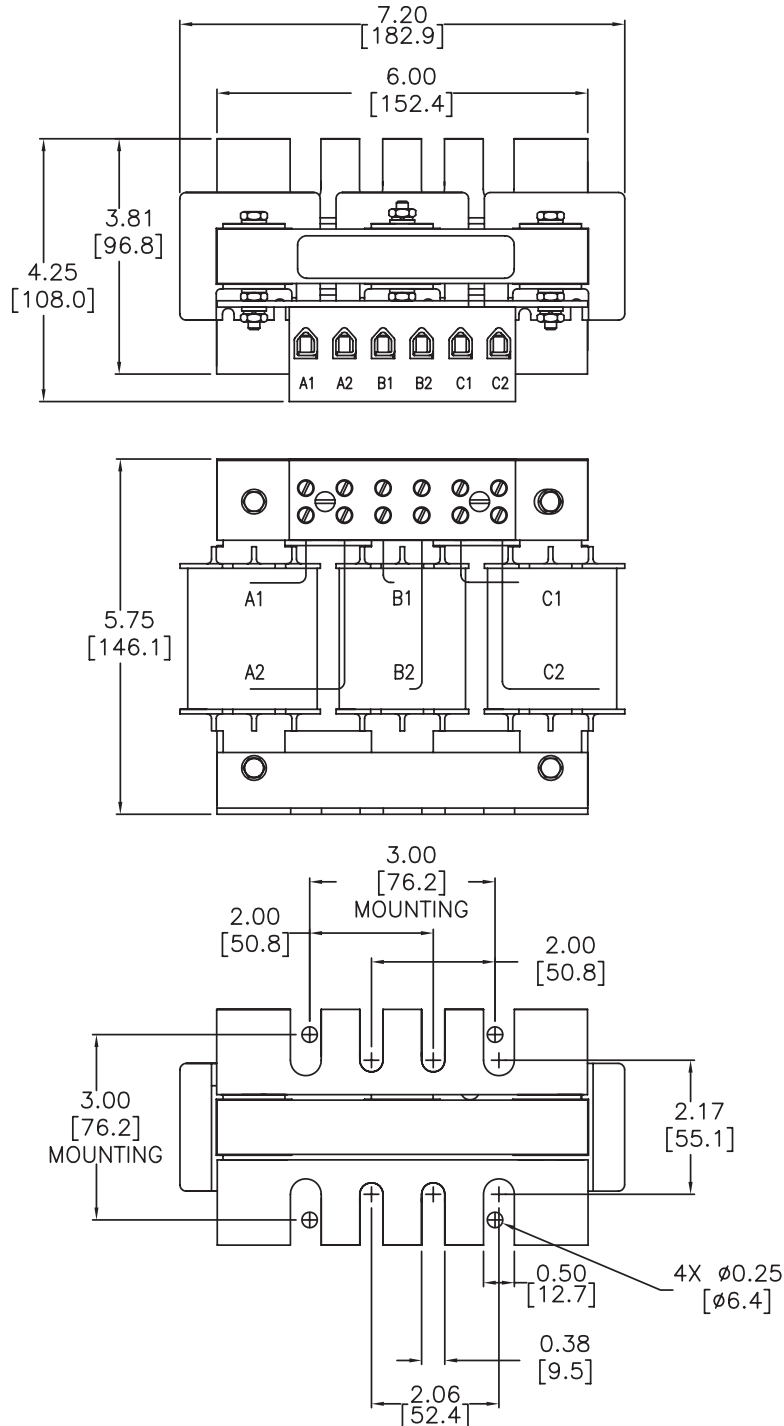

GS/DURAPULSE Drives Accessories

– Line Reactors

Line Reactor Dimensions

LR-2025, LR-4040

LR series reactors have universal mounting feet with multiple mounting slots, and they can replace most reactors using the existing mounting holes. Use four bolts to mount the reactors to the mounting panel.

(Units = inches [mm])

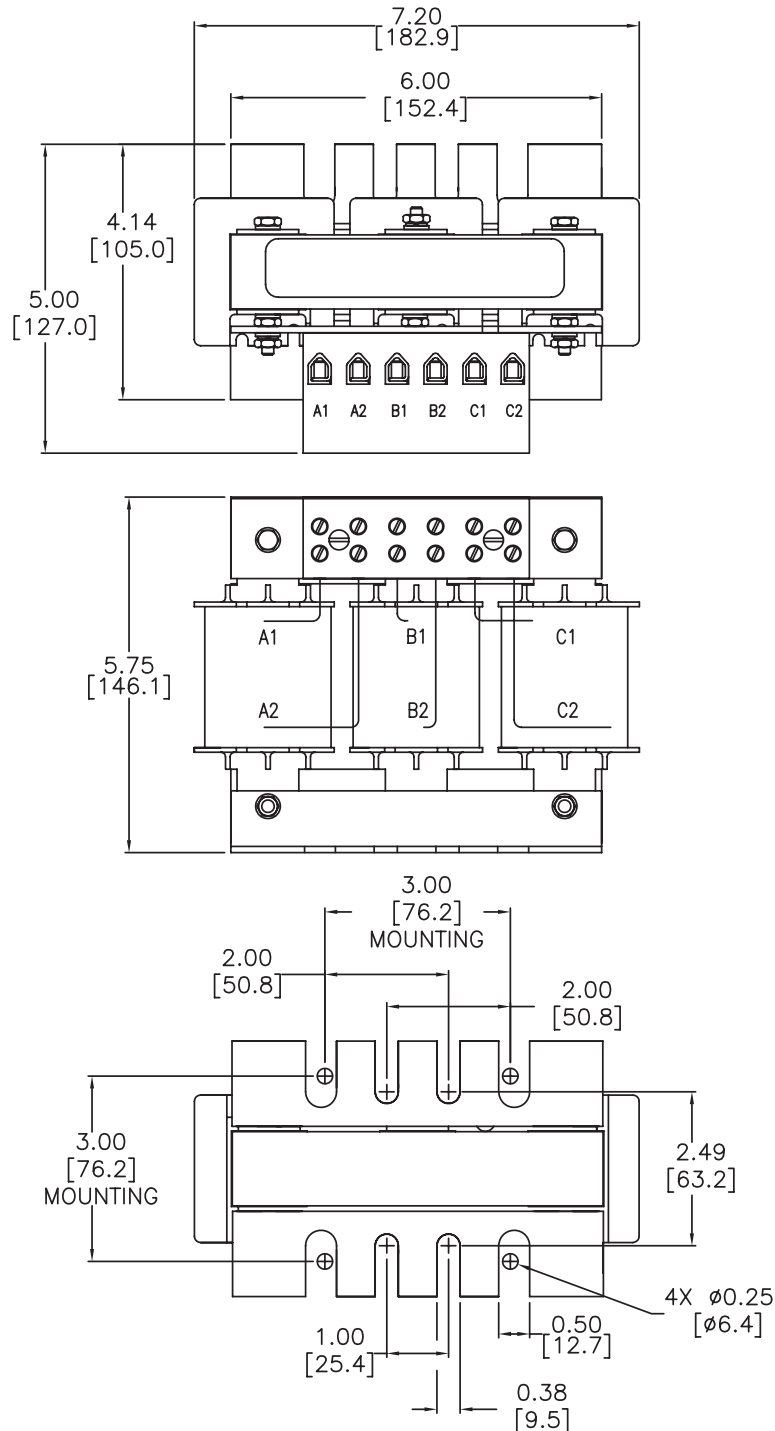

GS/DURAPULSE Drives Accessories

- Line Reactors

Line Reactor Dimensions

LR-2030, LR-2040, LR-4075

LR series reactors have universal mounting feet with multiple mounting slots, and they can replace most reactors using the existing mounting holes. Use four bolts to mount the reactors to the mounting panel.

(Units = inches [mm])

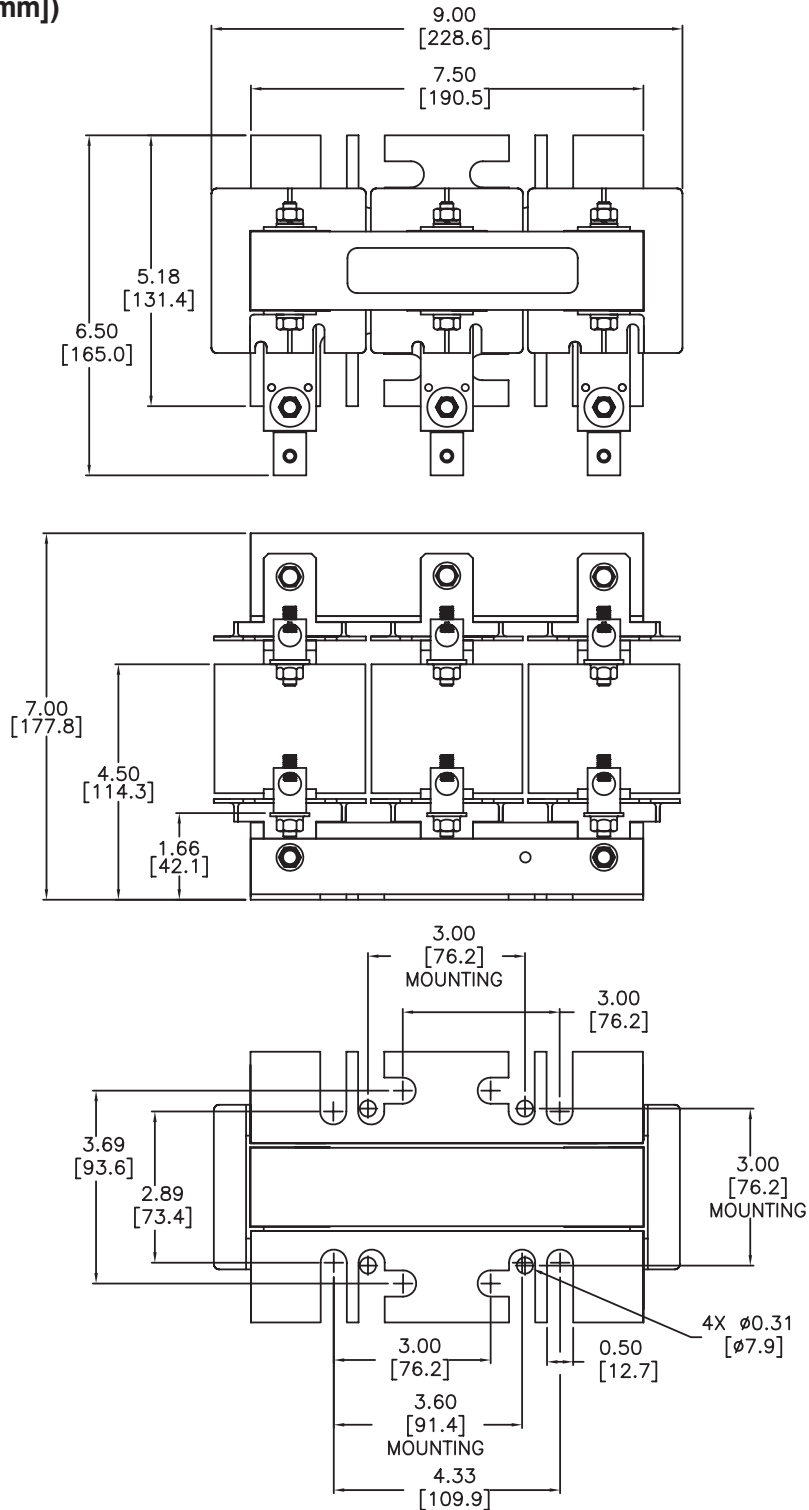

GS/DURAPULSE Drives Accessories

– Line Reactors

Line Reactor Dimensions

LR-4050, LR-4060

LR series reactors have universal mounting feet with multiple mounting slots, and they can replace most reactors using the existing mounting holes. Use four bolts to mount the reactors to the mounting panel.

(Units = inches [mm])

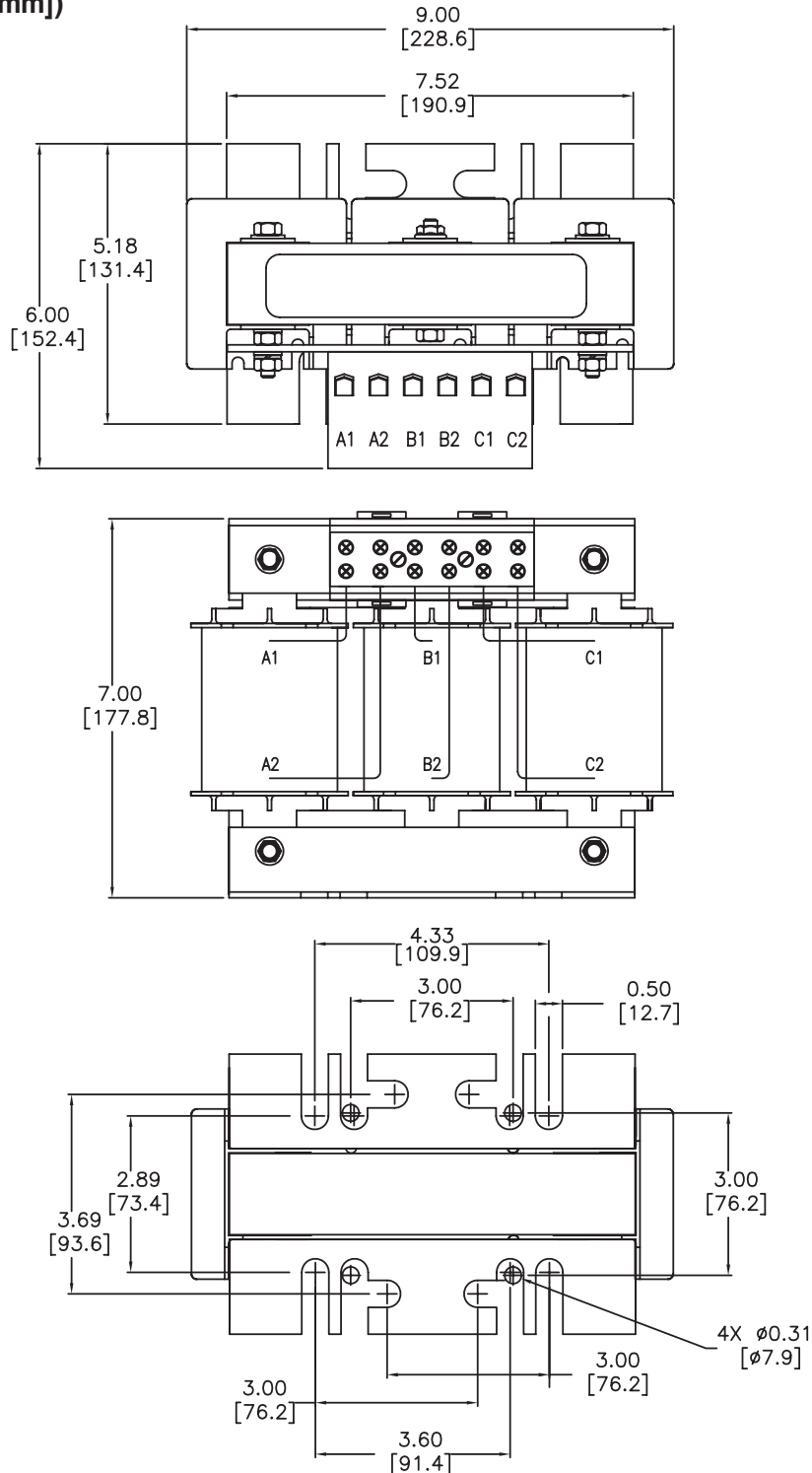

GS/DURAPULSE Drives Accessories

– Line Reactors

Line Reactor Dimensions

LR-4100, LR-4125, LR-4150

LR series reactors have universal mounting feet with multiple mounting slots, and they can replace most reactors using the existing mounting holes. Use four bolts to mount the reactors to the mounting panel.

(Units = inches [mm])

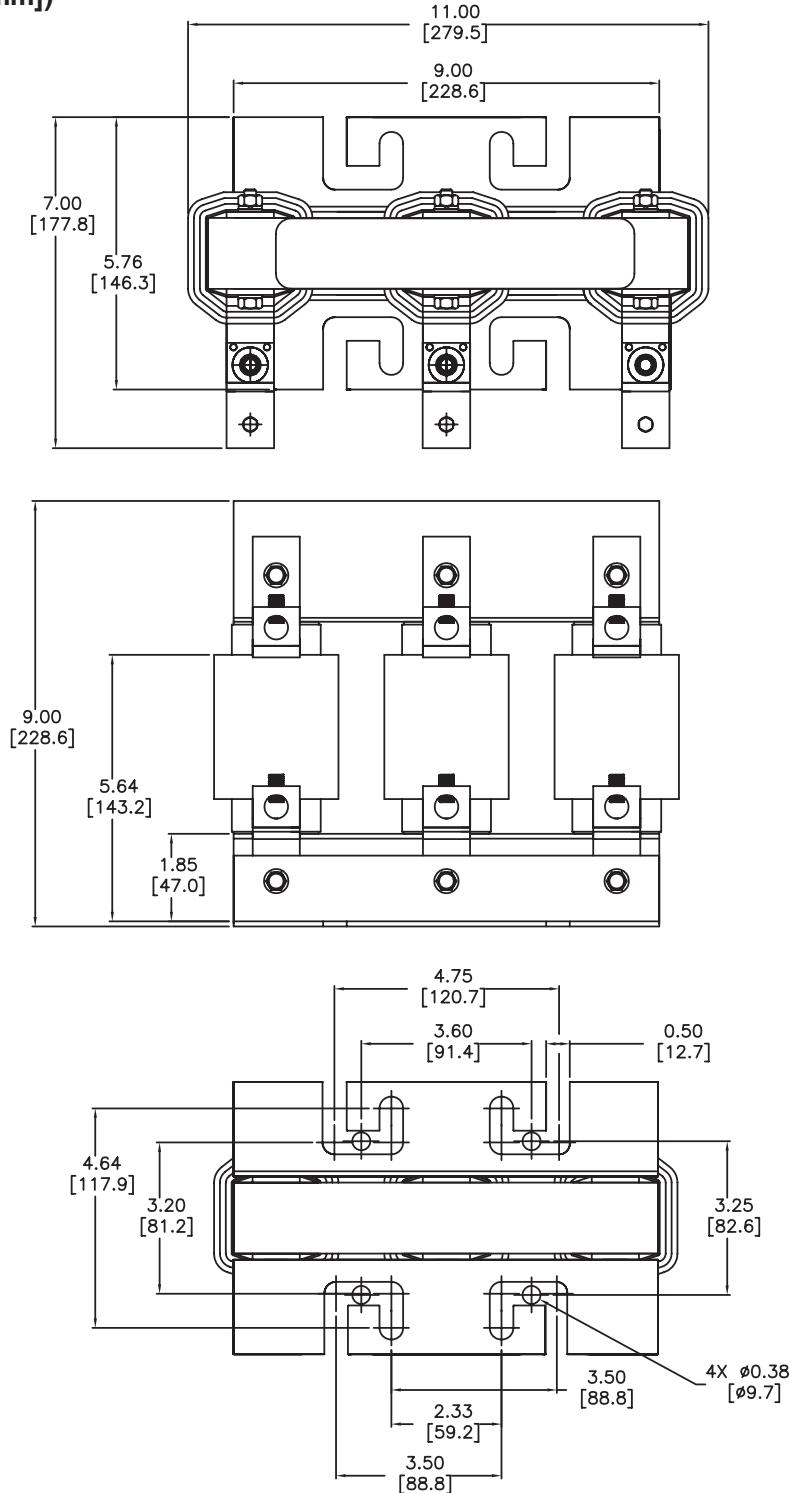

GS/DURAPULSE Drives Accessories

– Line Reactors

Line Reactor Dimensions

LR-4200

LR series reactors have universal mounting feet with multiple mounting slots, and they can replace most reactors using the existing mounting holes. Use four bolts to mount the reactors to the mounting panel.

(Units = inches [mm])

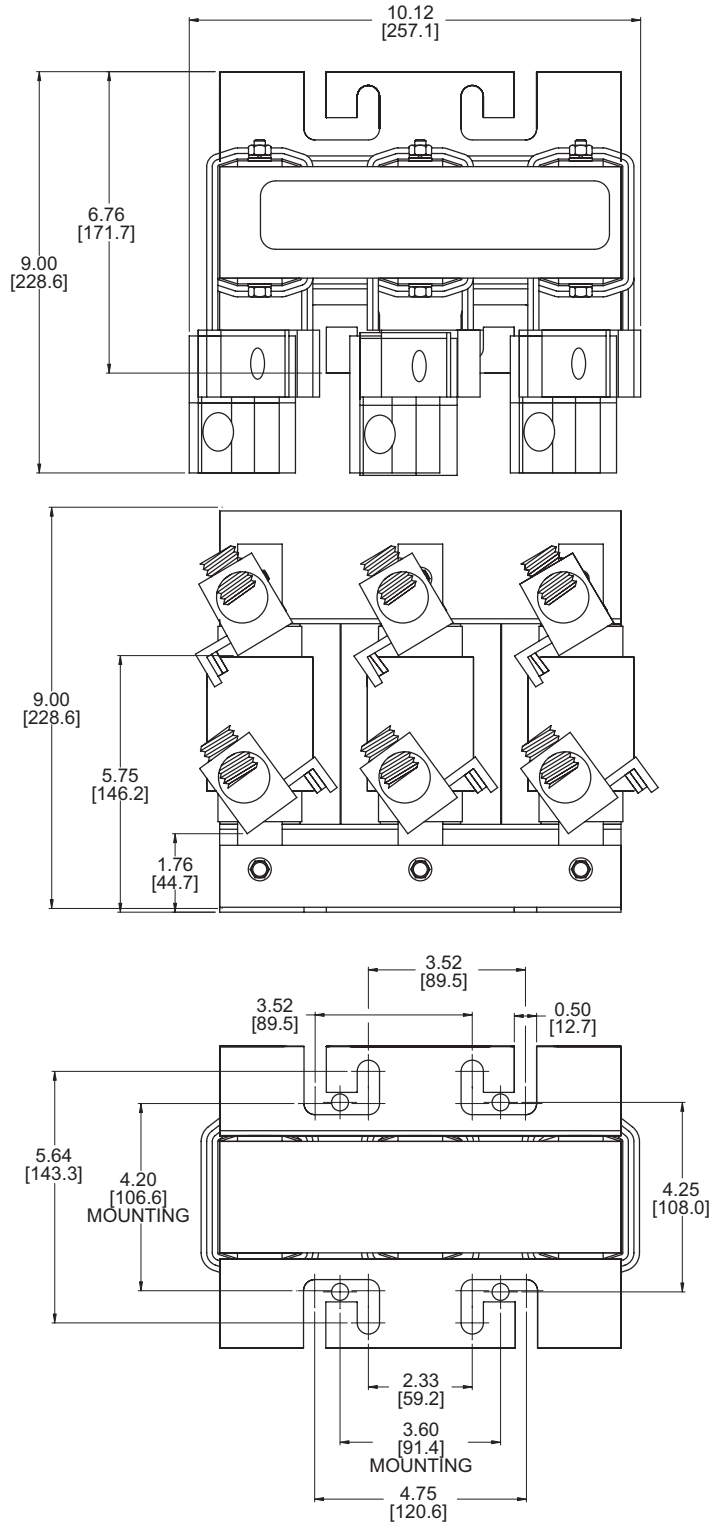

GS/DURAPULSE Drives Accessories

– Line Reactors

Line Reactor Dimensions

LR-4250, LR-4300

LR series reactors have universal mounting feet with multiple mounting slots, and they can replace most reactors using the existing mounting holes. Use four bolts to mount the reactors to the mounting panel.

(Units = inches [mm])

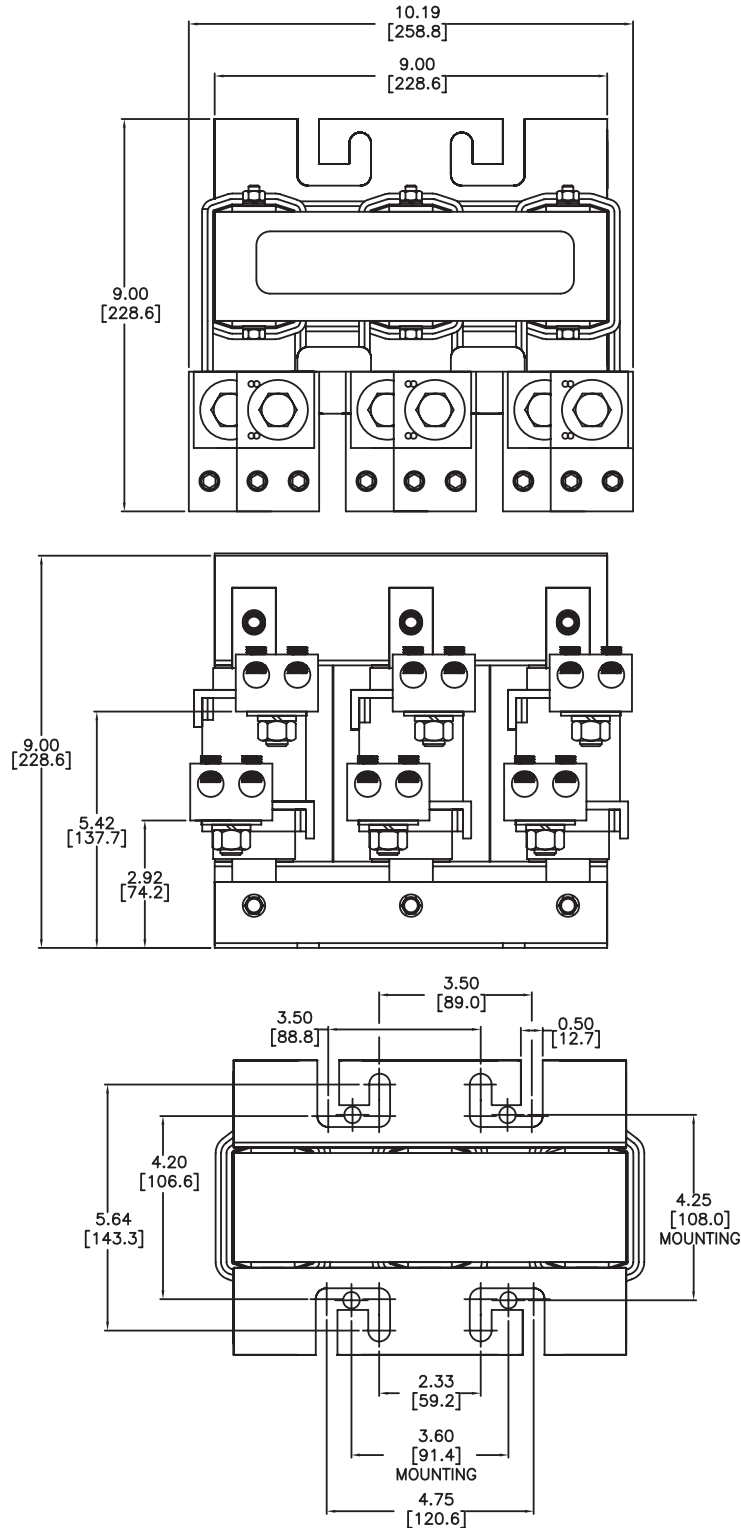

GS/DURAPULSE Drives Accessories

- Braking Units

Overview



BRAKING UNITS ARE AVAILABLE ONLY FOR DURAPULSE DRIVES.

Braking units are applied to absorb the motor regeneration energy when the three-phase induction motor stops by deceleration.

GS-2DBU and GS-4DBU, used with GS series braking resistors, provide optimum braking performance.



To avoid injury or mechanical damage, please refer to user manual GS3-DB-M before wiring.



DURApulse AC Drive Braking Units									
AC Drive		Brake Unit			Braking Resistor			Braking Torque 10% Duty Cycle	Typical Thermal Overload Relay Value
Voltage	AC Drive Part No.	QTY	Brake Unit Part No.	Price	QTY	Resistor Part No.	Resistor Specification for Each Braking Unit		
230V	GS3-2020	1	GS-2DBU	\$200.00	1	GS-2020-BR-ENC	3000 W / 10Ω	125%	30A
	GS3-2025	1			1	GS-2025-BR-ENC	4800 W / 8Ω	125%	35A
	GS3-2030	1			1	GS-2030-BR-ENC	4800 W / 6.8Ω	125%	40A
	GS3-2040	2			2	GS-2040-BR-ENC	3000 W / 10Ω	125%	30A
	GS3-2050	2			2	GS-2050-BR-ENC	3000 W / 10Ω	100%	30A
460V	GS3-4020	1	GS-4DBU	\$321.00	1	GS-4020-BR-ENC	1500 W / 40Ω	125%	15A
	GS3-4025	1			1	GS-4025-BR-ENC	4800 W / 32Ω	125%	15A
	GS3-4030	1			1	GS-4030-BR-ENC	4800 W / 27.2Ω	125%	20A
	GS3-4040	1			1	GS-4040-BR-ENC	6000 W / 20Ω	125%	30A
	GS3-4050	1			1	GS-4050-BR-ENC	9600 W / 16Ω	125%	40A
	GS3-4060	1			1	GS-4060-BR-ENC	9600 W / 13.6Ω	125%	50A
	GS3-4075	2			2	GS-4075-BR-ENC	6000 W / 20Ω	125%	30A
	GS3-4100	2			2	GS-4100-BR-ENC	9600 W / 13.6Ω	125%	50A

GS/DURAPULSE Drives Accessories

- Braking Units

Wiring Diagram (DURApulse only)

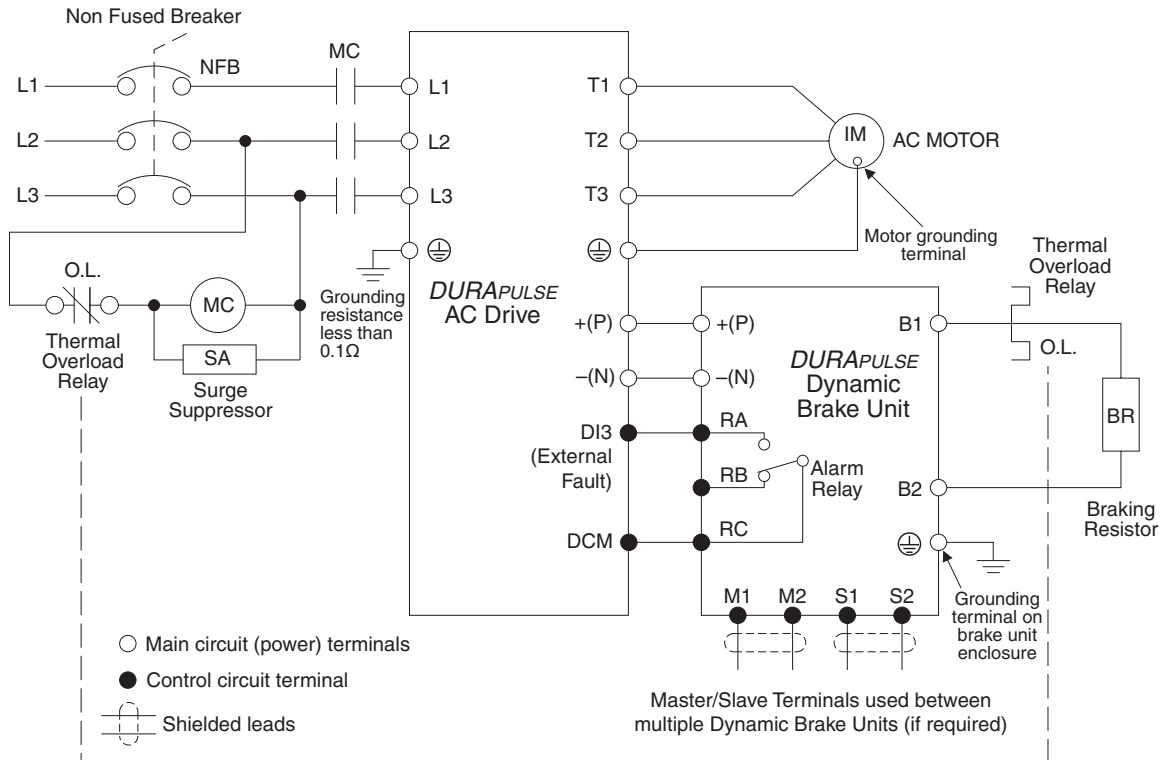

Dimensions

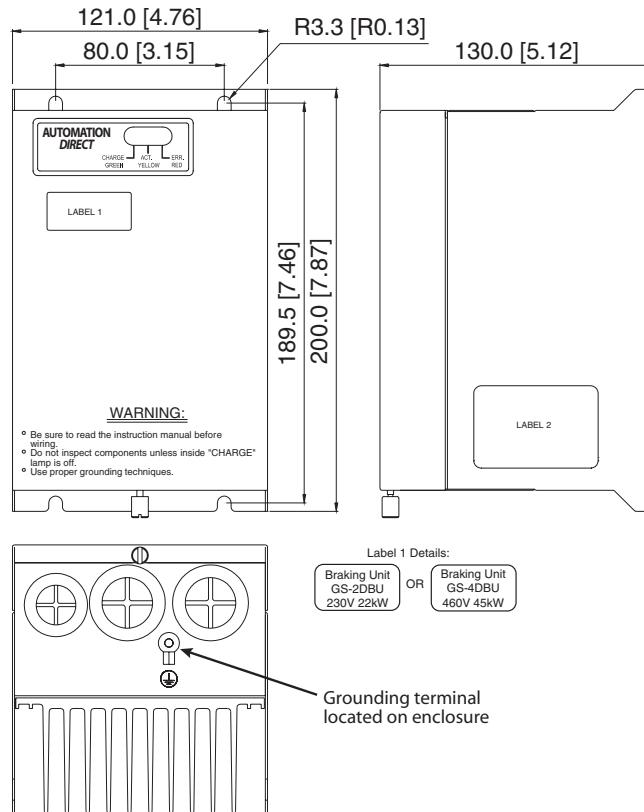

units: mm(in)

GS/DURAPULSE Accessories – Braking Resistors

Overview

Braking resistors are used to increase the control torque of the AC drive, for frequently repeated ON-OFF cycles of the AC drive, or for decelerating a load with large inertia.



FOR DURAPULSE DRIVE MODELS 20 HP AND ABOVE, A DYNAMIC BRAKING UNIT MUST BE USED IN CONJUNCTION WITH THE BRAKING RESISTOR, AS SHOWN IN THE DURAPULSE AC DRIVE BRAKING UNITS TABLE.



GS-25P0-BR



GS-27P5-BR

For additional information, please refer to the dynamic braking manual, GS3-DB-M.



GS-2020-BR-ENC



GS-2020-BR-ENC without Cover

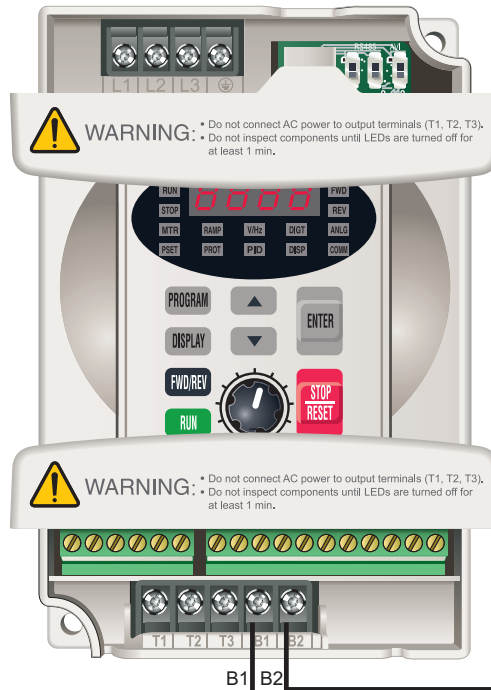

GS2 braking resistor connection;

Refer to user manuals GS3-M and GS3-DB-M for DURAPULSE resistor connection information.

GS/DURAPULSE Accessories

- Braking Resistors

Dynamic Braking Resistors								
Part Number	Quantity Required and Wiring	Price Each	Drive Model	Motor V / hp	Braking Torque ED 10%	Resistance (Ω)	Power (W)	Duty Cycle
GS-20P5-BR	1	\$42.50	GS2-10P2 GS2-10P5 GS2-20P5	115 / 0.25 115 / 0.5 230 / 0.5	270%	200Ω	80	10%
GS-21P0-BR	1	\$58.00	GS2-11P0 GS2/3-21P0	115 / 1 230 / 1	125%	200Ω	80	10%
GS-22P0-BR	1	\$65.00	GS2/3-22P0	230 / 2	125%	100Ω	300	10%
GS-23P0-BR	1	\$76.00	GS2/3-23P0	230 / 3	125%	70Ω	300	10%
GS-25P0-BR *	1	\$75.00	GS2/3-25P0	230 / 5	125%	40Ω	400	10%
GS-27P5-BR	1	\$71.00	GS2/3-27P5	230 / 7.5	125%	30Ω	500	10%
GS-2010-BR-ENC	1	\$223.00	GS3-2010	230 / 10	125%	20Ω	1000	10%
GS-2015-BR-ENC	1	\$391.00	GS3-2015	230 / 15	125%	13.6Ω	2400	10%
GS-2020-BR-ENC	1 (also 1 DBU)	\$435.00	GS3-2020	230 / 20	125%	10Ω	3000	10%
GS-2025-BR-ENC	1 (also 1 DBU)	\$525.00	GS3-2025	230 / 25	125%	8Ω	4800	10%
GS-2030-BR-ENC	1 (also 1 DBU)	\$525.00	GS3-2030	230 / 30	125%	6.8Ω	4800	10%
GS-2040-BR-ENC	2 (also 2 DBU)	\$435.00	GS3-2040	230 / 40	125%	10Ω x 2	3000 x 2	10%
GS-2050-BR-ENC	2 (also 2 DBU)	\$525.00	GS3-2050	230 / 50	125%	8Ω x 2	4800 x 2	10%
GS-41P0-BR	1	\$42.50	GS2/3-41P0	460 / 1	125%	750Ω	80	10%
GS-42P0-BR	1	\$64.00	GS2/3-42P0 GS2-51P0 GS2-52P0	460 / 2 575 / 1 575 / 2	125%	400Ω	300	10%
	2 / parallel		GS2-53P0 GS2-55P0 GS2-57P5	575 / 3 575 / 5 575 / 7.5				
GS-43P0-BR	1	\$64.00	GS2/3-43P0	460 / 3	125%	250Ω	300	10%
GS-45P0-BR	1	\$64.00	GS2/3-45P0	460 / 5	125%	150Ω	400	10%
GS-47P5-BR	1	\$95.00	GS2/3-47P5	460 / 7.5	125%	100Ω	500	10%
GS-4010-BR	1	\$139.00	GS2/3-4010	460 / 10	125%	75Ω	1000	10%
	2 / series		GS2-5010	575 / 10				
GS-4015-BR-ENC	1	\$223.00	GS3-4015	460 / 15	125%	50Ω	1000	10%
GS-4020-BR-ENC	1 (also 1 DBU)	\$279.00	GS3-4020	460 / 20	125%	40Ω	1500	10%
GS-4025-BR-ENC	1 (also 1 DBU)	\$659.00	GS3-4025	460 / 25	125%	32Ω	4800	10%
GS-4030-BR-ENC	1 (also 1 DBU)	\$659.00	GS3-4030	460 / 30	125%	27.2Ω	4800	10%
GS-4040-BR-ENC	1 (also 1 DBU)	\$659.00	GS3-4040	460 / 40	125%	20Ω	6000	10%
GS-4050-BR-ENC	1 (also 1 DBU)	\$783.00	GS3-4050	460 / 50	125%	16Ω	9600	10%
GS-4060-BR-ENC	1 (also 1 DBU)	\$783.00	GS3-4060	460 / 60	125%	13.6Ω	9600	10%
GS-4075-BR-ENC	2 (also 2 DBU)	\$659.00	GS3-4075	460 / 75	125%	20Ω x 2	6000 x 2	10%
GS-4100-BR-ENC	2 (also 2 DBU)	\$783.00	GS3-4100	460 / 100	125%	13.6Ω x 2	9600 x 2	10%

NOTE: Dynamic braking resistors not available for GS1 series AC drives.

NOTE: The use of dynamic braking resistors with GS2 series AC drives requires no parameter setup. The AC drive will automatically sense the presence of a braking resistor.

NOTE: For DURAPULSE GS3 series AC drives 20 hp and above, dynamic braking units must be used in conjunction with braking resistors.

* GS-25P0-BR can be also be used with SureServo AC Servo Drive # SVA-2040.

GS/DURAPULSE Accessories

– Braking Resistors

Dimensions

Braking Resistors Dimensions								
Part Number	Enclosure	Figure	Weight (g)	L1 (mm)	L2 (mm)	H (mm)	D (mm)	W (mm)
GS-20P5-BR	none	1	160	140	125	20	5.3	40
GS-21P0-BR			160	140	125	20	5.3	60
GS-22P0-BR			750	215	200	30	5.3	60
GS-23P0-BR			750	215	200	30	5.3	60
GS-25P0-BR			930	265	250	30	5.3	60
GS-27P5-BR		2	1100	335	320	30	53	60
GS-2010-BR-ENC *	GCE3	3	dimensions shown in diagram					
GS-2015-BR-ENC	GCE6	4						
GS-2020-BR-ENC	GCE9	5						
GS-2025-BR-ENC								
GS-2030-BR-ENC	GCE6	4						
GS-2040-BR-ENC	GCE9	5						
GS-2050-BR-ENC								
GS-41P0-BR	none	1	160	140	125	20	5.3	60
GS-42P0-BR			750	215	200	30	5.3	60
GS-43P0-BR			750	215	200	30	5.3	60
GS-45P0-BR			930	265	250	30	5.3	60
GS-47P5-BR		2	1100	335	320	30	5.3	60
GS-4010-BR								
GS-4015-BR-ENC	GCE3	3	dimensions shown in diagram					
GS-4020-BR-ENC	GCE4	6						
GS-4025-BR-ENC	GCE12	7						
GS-4030-BR-ENC								
GS-4040-BR-ENC	GCE15	8						
GS-4050-BR-ENC								
GS-4060-BR-ENC	GCE12	7						
GS-4075-BR-ENC	GCE15	8						
GS-4100-BR-ENC								

Note: For DURAPULSE drive models 20HP and above, a dynamic braking unit must be used in conjunction with the braking resistor, as shown in the Braking Units and Braking Resistors tables. For additional information, refer to the dynamic braking manual, GS3-DB-M.

** GS-2010-BR-ENC can be also be used with SureServo AC Servo Drive #s SVA-2100 & SVA-2300.*

GS/DURAPULSE Accessories

– Braking Resistors

Figure 1

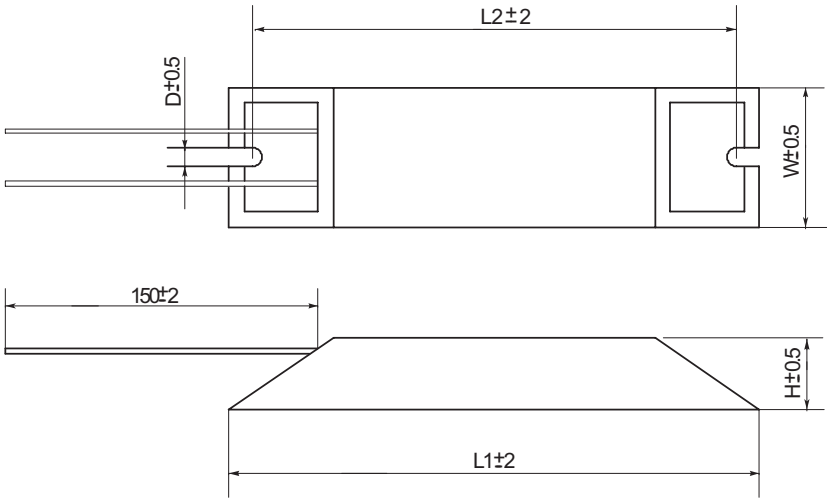

Figure 2

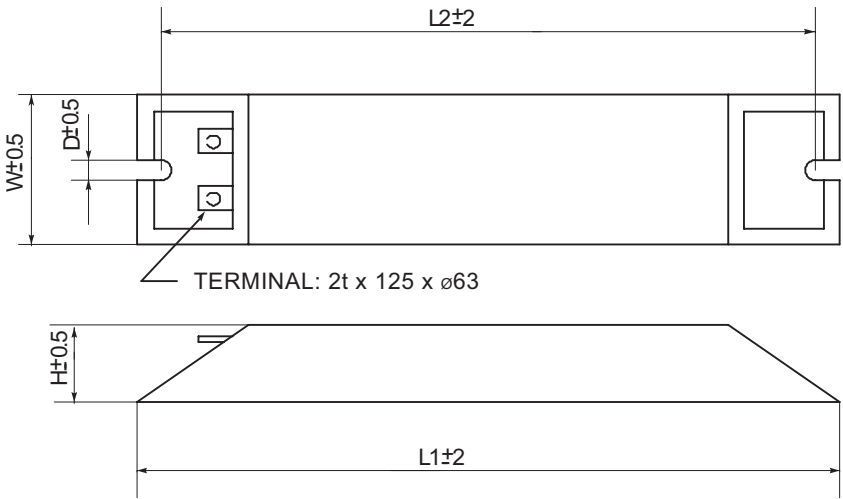

Figure 3

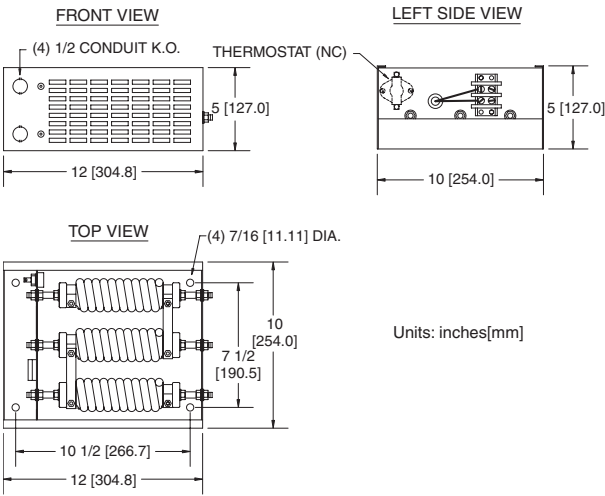
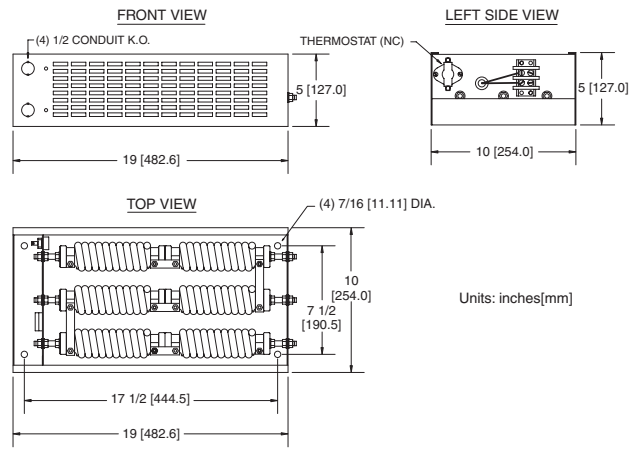

Figure 4



Units: inches[mm]

GS/DURAPULSE Accessories

– Braking Resistors

Figure 5

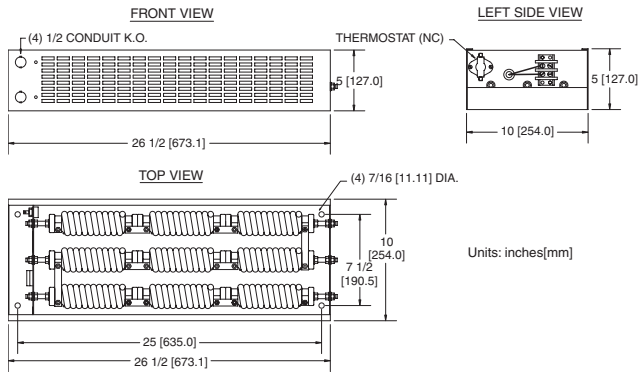

Figure 6

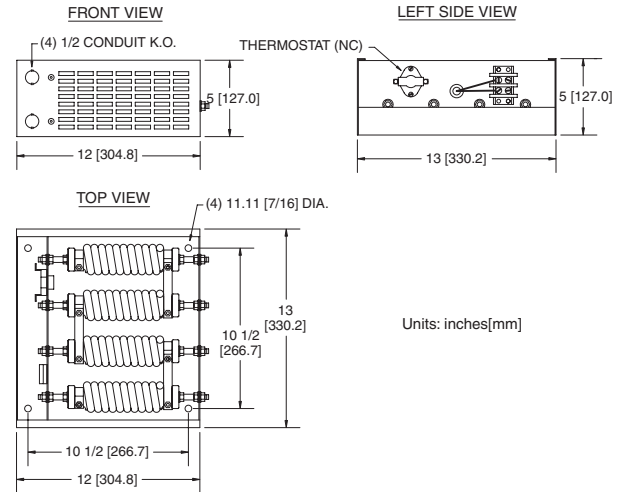

Figure 7

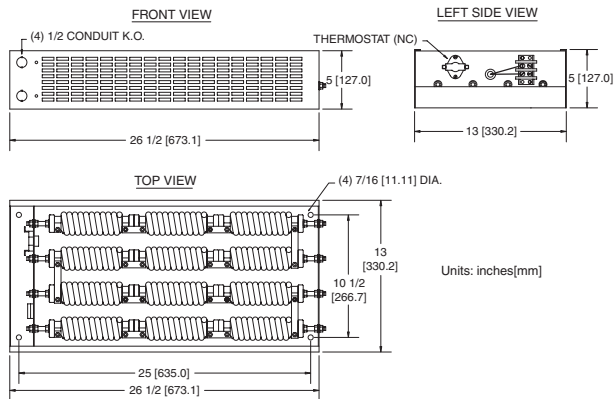
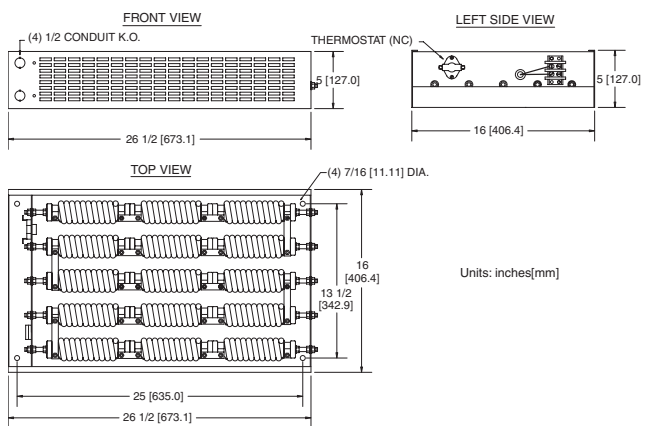

Figure 8



GS/DURAPULSE Accessories – EMI Filters

Overview

The CE Declaration of Conformity for the GS2 and DURAPULSE AC drives was completed in conjunction with the EMI filters listed. Use the following table to specify the corresponding EMI filter for each AC drive model.

CE compliance requires the use of EMI filters for GS2 and DURAPULSE AC drives. GS1 AC drives have internal EMI filtering, and do not require separate filters.

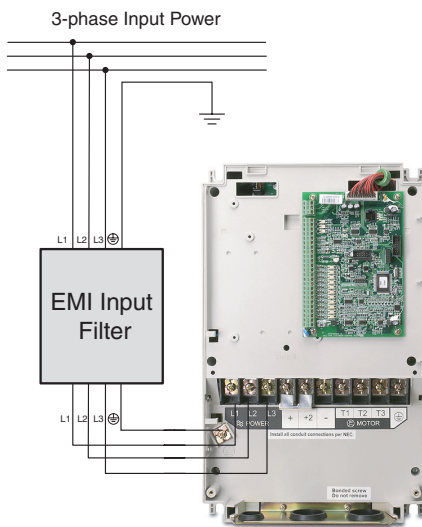

GS3-4030 shown

EMI Input Filter Specifications						
GS AC Drive 115V / 230V	GS AC Drive 460V / 575V	AC Servo Drive	EMI Filter	Price	Input Power	Dimen-sions
GS2-1xxx	-	SVA-2040 (1-ph) *	20DRT1W3S	\$76.00	1-phase, 20A	Figure 1
GS2-20P5 (1-ph)		SVA-2100 (1-ph) *				
GS2-21P0 (1-ph)						
GS2-22P0 (1-ph)						
GS2-21P0 (1-ph)						
GS3-22P0 (1-ph)						
GS2-23P0 (1-ph)	-	-	32DRT1W3C	\$98.00	1-phase, 32A	Figure 2
GS3-23P0 (1-ph)						
GS2-25P0	-	-	40TDS4W4B	\$103.00	3-phase, 40A	Figure 3
GS2-27P5						
-	GS2-41P0	-	11TDT1W4S	\$103.00	3-phase, 11A	Figure 4
-	GS2-42P0					
-	GS2-43P0					
-	GS2-45P0	-	17TDT1W44	\$103.00	3-phase, 17A	Figure 5
-	GS2-47P5					
-	GS2-4010	-	26TDT1W4B4	\$123.00	3-phase, 26A	Figure 6
GS2-20P5 (3-ph)	GS2-5xxx	-	not available	n/a		
GS2-21P0 (3-ph) *	-	SVA-2040 (3-ph) *	10TDT1W4C	\$81.00	3-phase, 10A	Figure 7
GS2-22P0 (3-ph) *		SVA-2100 (3-ph) *				
GS3-21P0						
GS3-22P0						
GS2-23P0 (3-ph) *	-	SVA-2300 (3-ph) *	26TDT1W4C	\$113.00	3-phase, 26A	Figure 8
GS3-23P0						
GS3-25P0						
GS3-27P5	GS3-4020	-	50TDS4W4C	\$173.00	3-phase, 50A	Figure 9
GS3-2010	GS3-4025					
GS3-2015	GS3-4030					
GS3-2020	GS3-4040	-	100TDS84C	\$272.00	3-phase, 100A	Figure 10
-	GS3-4050					
GS3-2025	GS3-4060					
GS3-2030	-	-	150TDS84C	\$306.00	3-phase, 150A	Figure 11
GS3-2040						
GS3-2050	-	-	180TDS84C	\$310.00	3-phase, 180A	Figure 12
-	GS3-41P0	-	RF022B43AA	\$77.00	3-phase, 5.9A	Figure 13
-	GS3-42P0					
-	GS3-43P0					
-	GS3-45P0	-	RF037B43BA	\$111.00	3-phase, 11.2A	Figure 14
-	GS3-47P5	-	RF110B43CA	\$156.00	3-phase, 25A	Figure 15
-	GS3-4010					
-	GS3-4015					
-	GS3-4075	-	200TDDS84C	\$967.00	3-phase, 200A	Figure 16
-	GS3-4100					

* EMI filters 10TDT1W4C and 26TDT1W4C mount underneath DURApulse drives, but do NOT mount underneath GS2 drives. They also do NOT mount underneath SureServo AC Servo drives.

GS/DURAPULSE Accessories – EMI Filters

Dimensions

Figure 1 [units = mm]

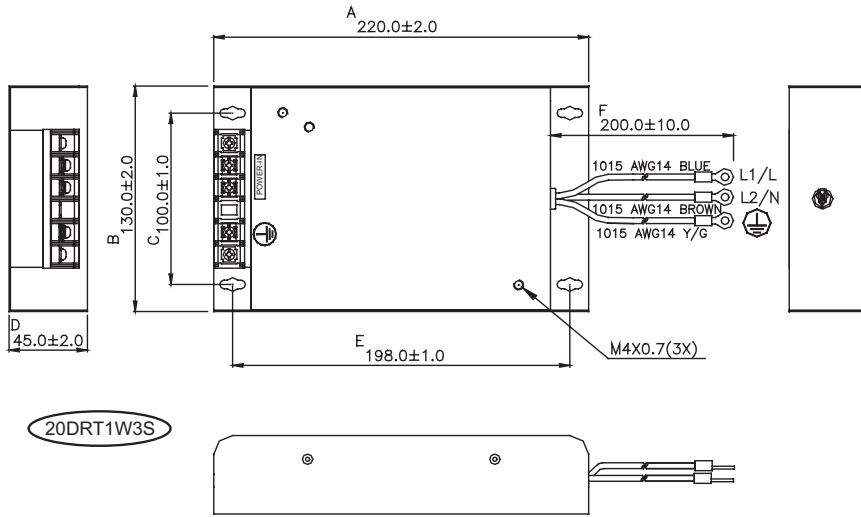

Figure 2 [units = mm]

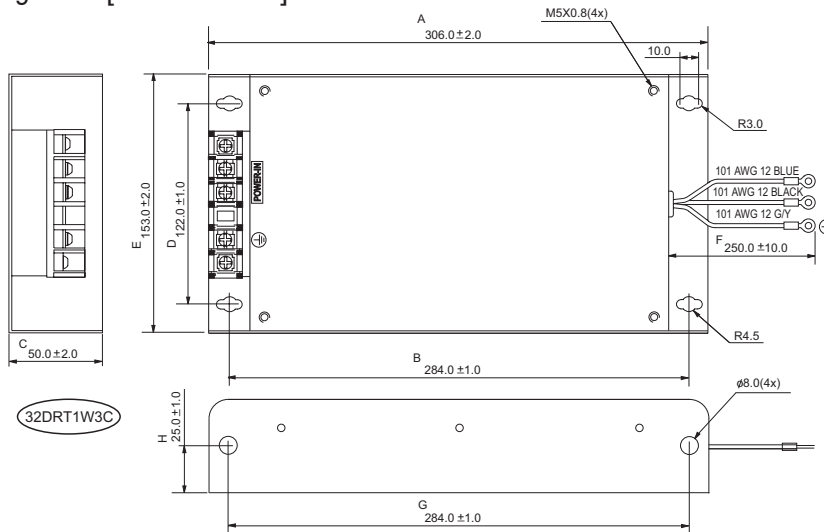
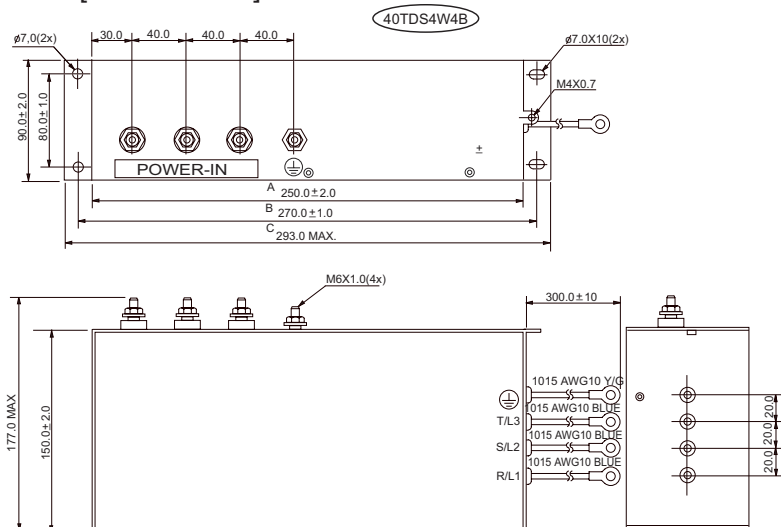

Figure 3 [units = mm]



GS/DURAPULSE Accessories – EMI Filters

Figure 4 [units = mm]

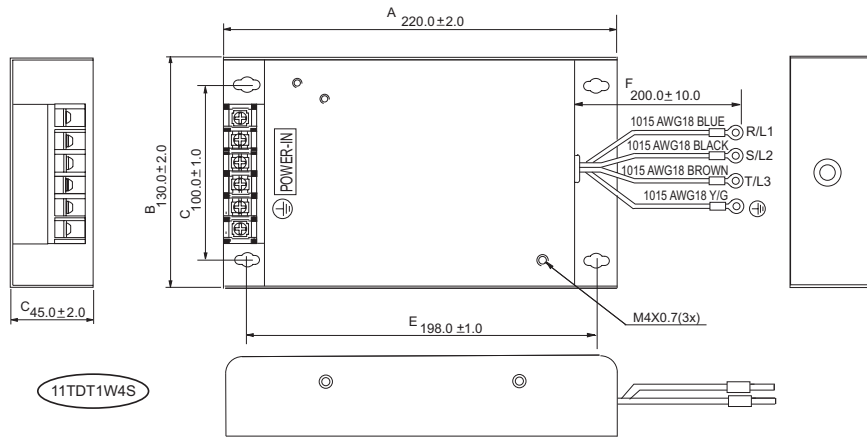

Figure 5 [units = mm]

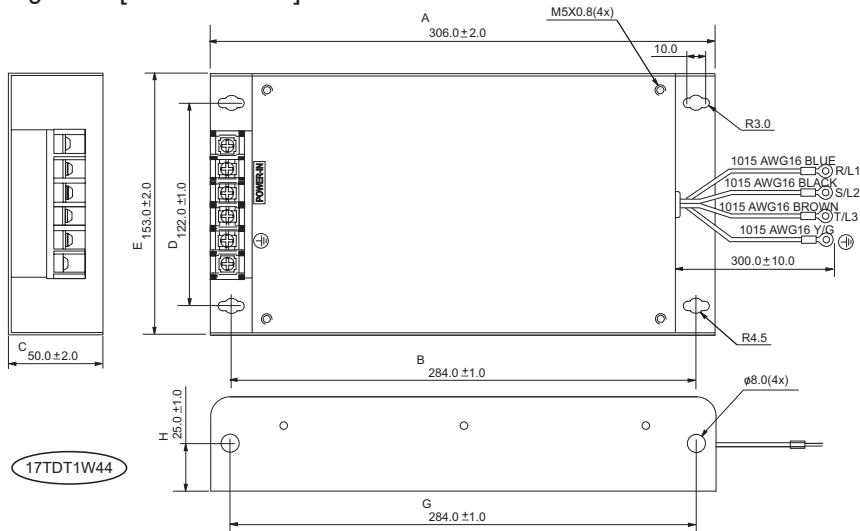
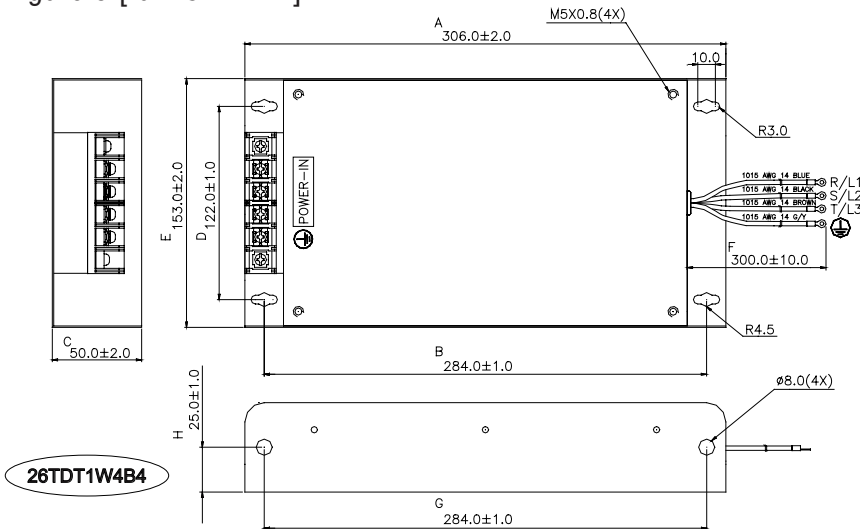

Figure 6 [units = mm]



GS/DURAPULSE Accessories – EMI Filters

Figure 7 [units = mm (in)]

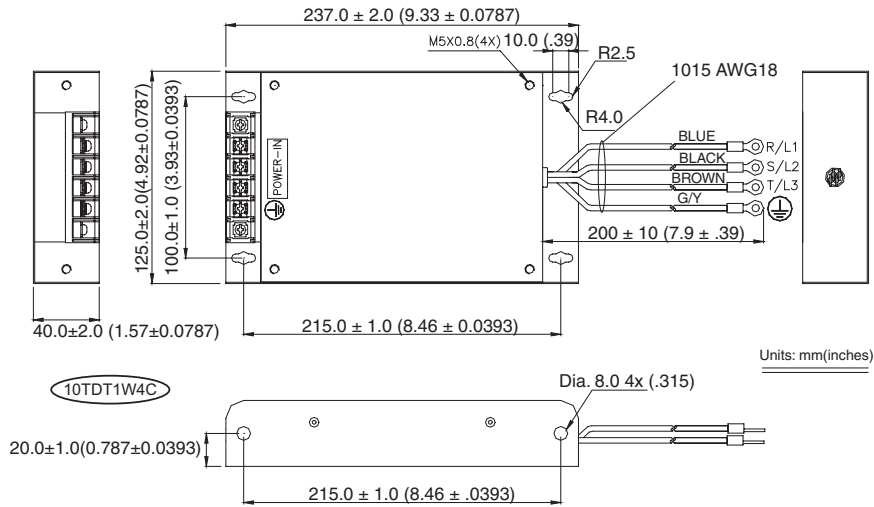

Figure 8 [units = mm (in)]

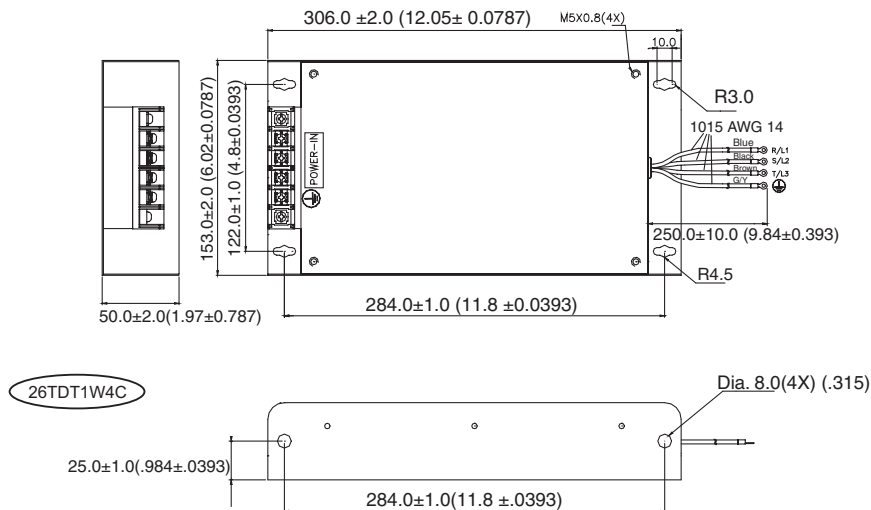
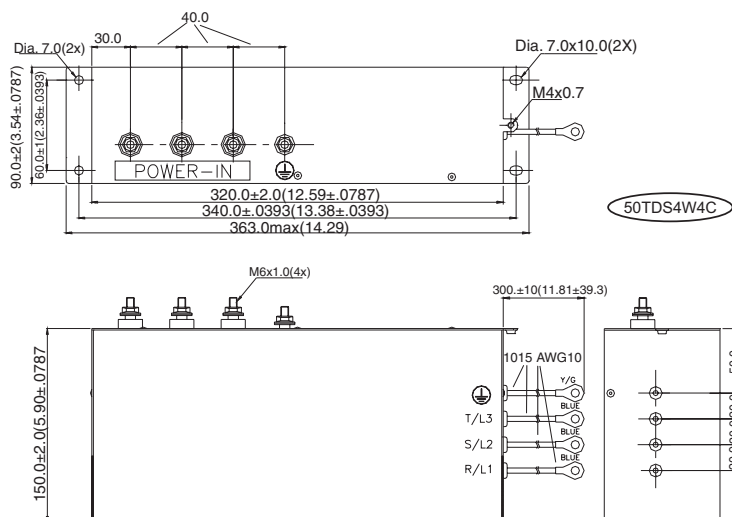

Figure 9 [units = mm (in)]



GS/DURAPULSE Accessories – EMI Filters

Figure 10 [units = mm (in)]

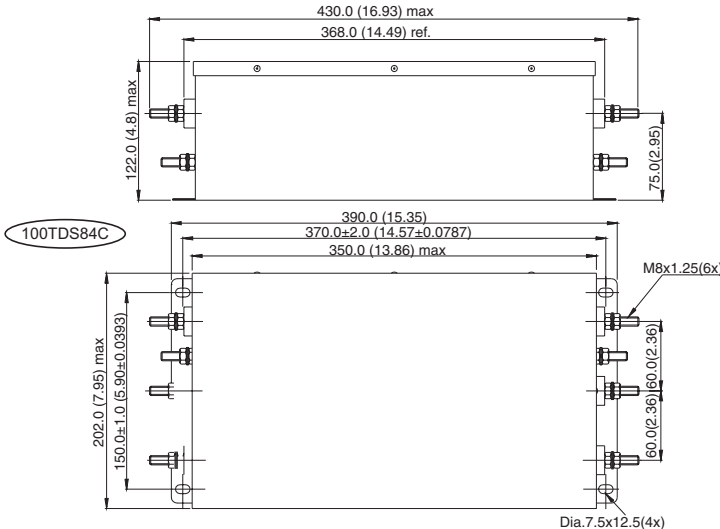

Figure 11 [units = mm (in)]

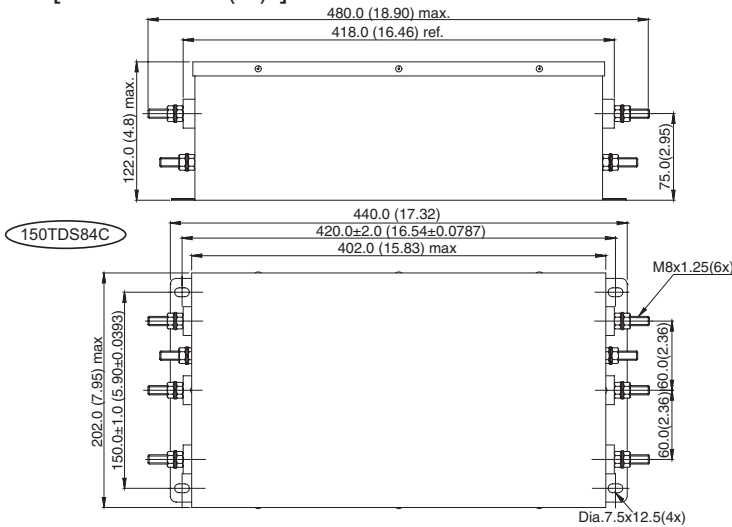
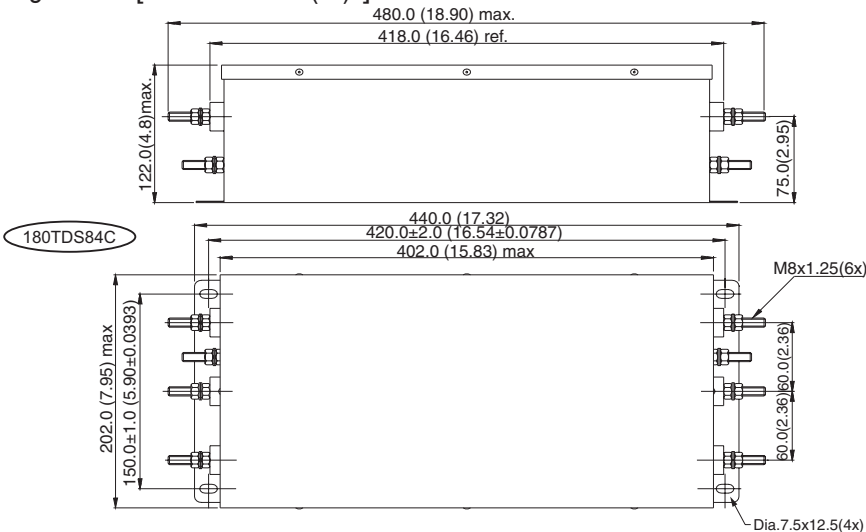

Figure 12 [units = mm (in)]



GS/DURAPULSE Accessories – EMI Filters

Figure 13 [units = mm (in)]

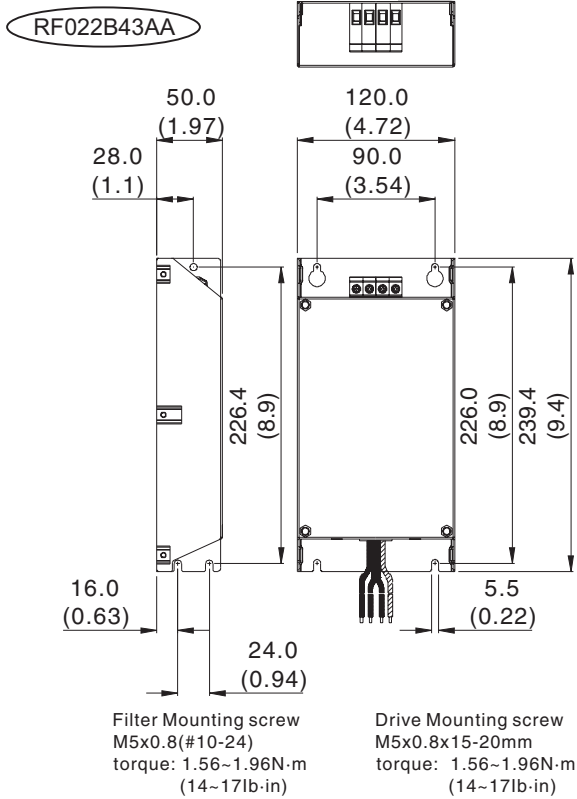

Figure 14 [units = mm (in)]

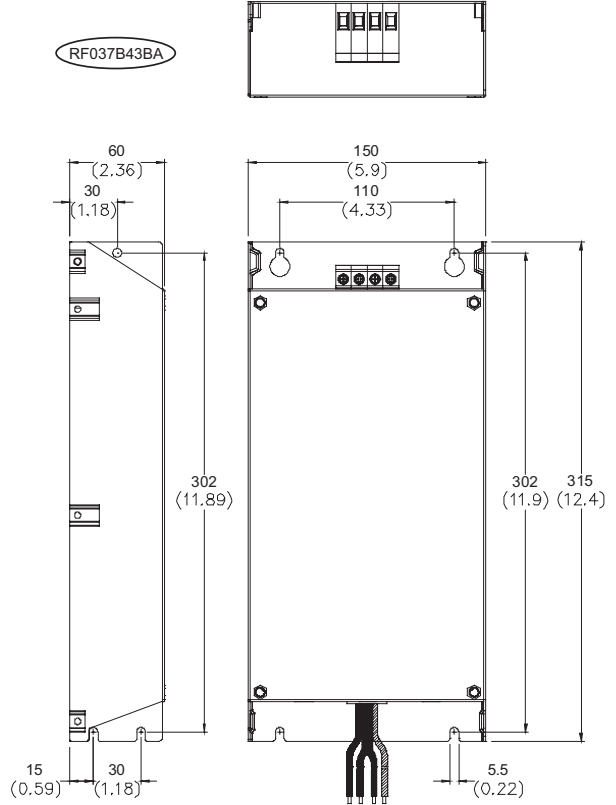

Figure 15 [units = mm (in)]

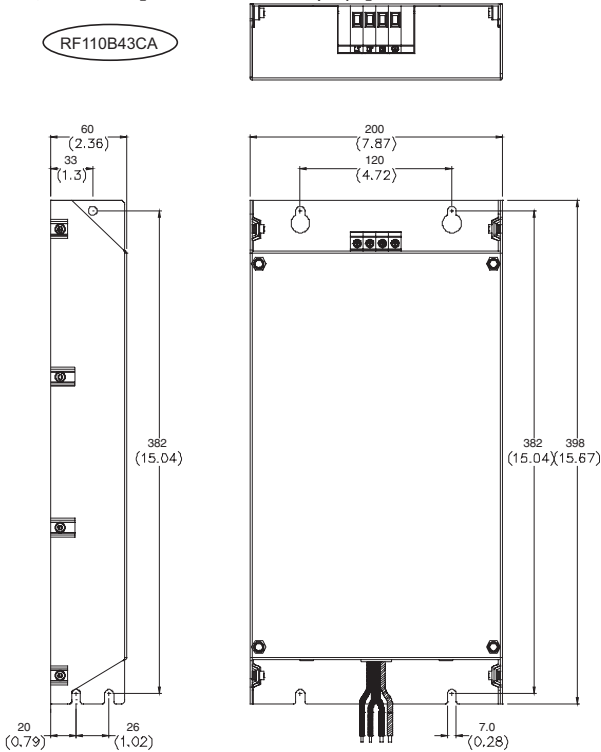
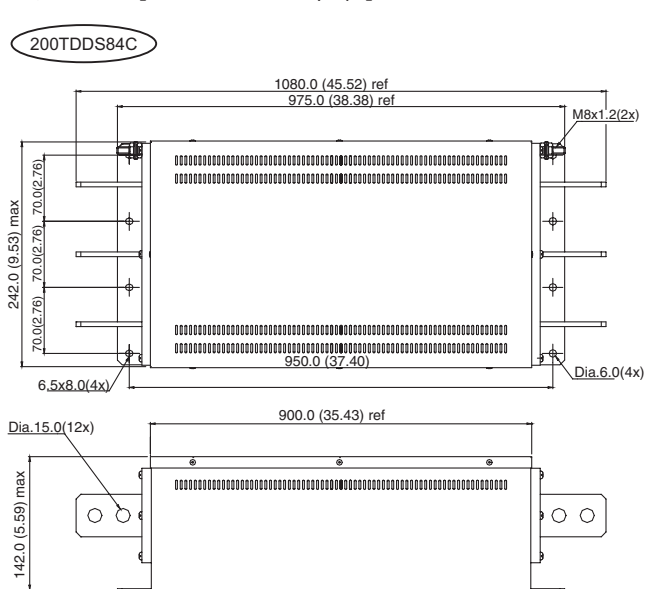

Figure 16 [units = mm (in)]



GS/DURAPULSE Accessories – RF Filter

RF Filter for GS/DURAPULSE AC Drives		
Part Number	Price	Drive Model
RF220X00A	\$26.00	GSx-xxxx
Can be used with all series GS/DURAPULSE AC drives		

Description

Zero phase reactors, (aka RF noise filters) help reduce radiated noise from the inverter wiring. The wiring must go through the opening to reduce the RF component of the electrical noise. Loop the wires three times (four turns) to attain the full RF filtering effect. For larger wire sizes, place multiple zero-phase reactors (up to four) side by side for a greater filtering effect. These are effective for noise reduction on both the input and output sides of the inverter. Attenuation quality is good in a wide range from AM band to 10 Mhz.

Wiring Method

Wind each wire four times around the core, as shown in diagram A to the right. The reactor must be put at inverter side as closely as possible.

If you are unable to wire as above due to wire size or another aspect of your application, put all wires through four cores in series without winding, as in diagram B to the right.

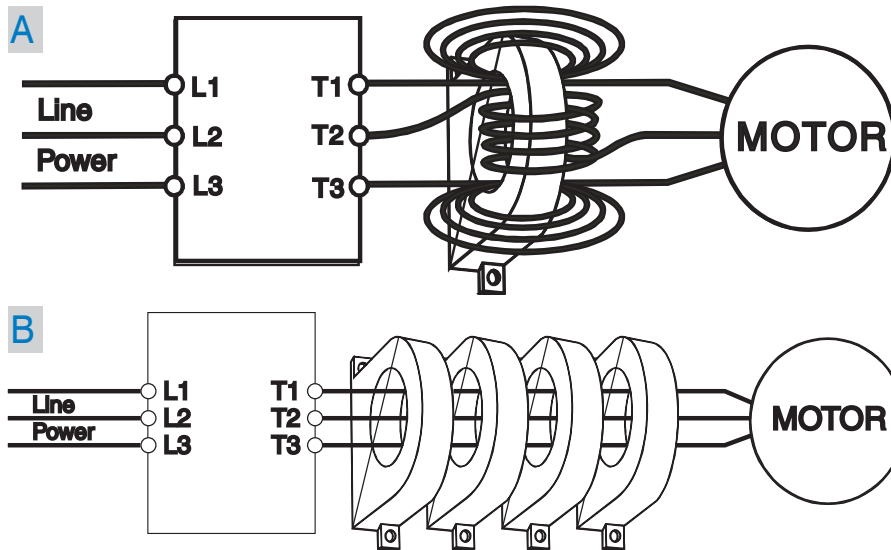
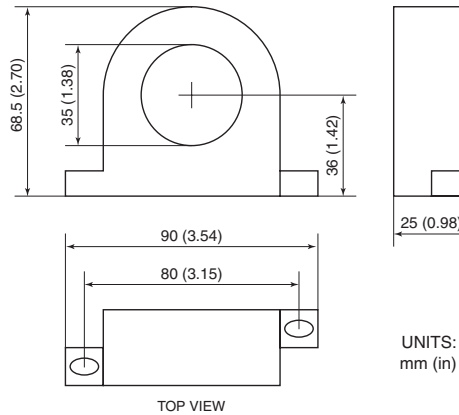

GS/DURAPULSE Accessories – Fusing

Fusing Overview

Circuit protection devices are essential to prevent costly damage to your AC drive application equipment. Fuses and fuse kits are available from AUTOMATIONDIRECT for the GS2 and DURAPULSE AC drives. (AutomationDirect GS style fuses and fuse kits are NOT available for GS1 drives at this time.)

The fuse specifications are shown in the table below. Each fuse kit consists of one fuse block and fuses sized to handle the inrush current while providing superior protection for the corresponding GS2 or DURAPULSE AC drive. The larger drives in the DURAPULSE family require three fuse kits (one per phase). Their part numbers are marked in the

table with a double asterisk.

Replacement fuses are also available, and listed in the table next to their companion fuse kits.

Fuse Kit Specifications for GS2 and DURAPULSE 115–460V Drives											
Fuse Kit	Price	Fuse Block Type	Wire Range	Fuse Type	Fuse Block Dimensions	Fuse Rating	SCCR	Replacement Fuses (5 fuses per package)	Price		
GS-10P2-FKIT-1P*	\$35.00	Two-pole	Al/Cu #2-14	A3T	Figure 1	300V@20A	200 kA	GS-10P2-FUSE-1P	\$44.00		
GS-10P5-FKIT-1P*	\$35.00					300V@30A		GS-10P5-FUSE-1P	\$41.50		
GS-11P0-FKIT-1P*	\$35.00					300V@50A		GS-11P0-FUSE-1P	\$44.00		
GS-20P2-FKIT-1P	\$35.00					300V@15A		GS-20P2-FUSE-1P	\$38.00		
GS-20P2-FKIT-3P	\$36.00	Three-pole			Al/Cu #2-14	A3T		Figure 2	300V@10A	GS-20P2-FUSE-3P	\$44.00
GS-20P5-FKIT-1P	\$35.00	Two-pole						Figure 1	300V@20A	GS-20P5-FUSE-1P	\$44.00
GS-20P5-FKIT-3P	\$36.00	Three-pole						Figure 2	300V@10A	GS-20P5-FUSE-3P	\$41.50
GS-21P0-FKIT-1P	\$35.00	Two-pole						Figure 1	300V@30A	GS-21P0-FUSE-1P	\$44.00
GS-21P0-FKIT-3P	\$36.00	Three-pole						Figure 2	300V@20A	GS-21P0-FUSE-3P	\$41.50
GS-22P0-FKIT-1P	\$35.00	Two-pole						Figure 1	300V@45A	GS-22P0-FUSE-1P	\$44.00
GS-22P0-FKIT-3P	\$41.50	Three-pole						Figure 2	300V@25A	GS-22P0-FUSE-3P	\$41.50
GS-23P0-FKIT-1P	\$35.00	Two-pole						Al/Cu 2/0-#6	A6T	Figure 1	300V@60A
GS-23P0-FKIT-3P	\$46.00	Three-pole	Figure 2	300V@40A			GS-23P0-FUSE-3P			\$44.00	
GS-25P0-FKIT	\$49.00		300V@60A	GS-25P0-FUSE			\$33.00				
GS-27P5-FKIT	\$81.00		Figure 9	300V@100A			GS-27P5-FUSE			\$46.00	
- †			Figure 4	300V@125A			GS-2010-FUSE			\$54.00	
- †		300V@175A		GS-2015-FUSE	\$54.00						
GS-2020-FKIT	\$208.00	Figure 5		300V@250A	GS-2020-FUSE	\$111.00					
GS-2025-FKIT	\$221.00			300V@300A	GS-2025-FUSE	\$111.00					
GS-2030-FKIT	\$221.00		300V@350A	GS-2030-FUSE	\$105.00						
GS-2040-FKIT**	\$231.00	One-pole	Figure 6 **	300V@450A	GS-2040-FUSE	\$57.00					
GS-2050-FKIT**	\$243.00	One-pole		300V@500A	GS-2050-FUSE	\$150.00					
GS-41P0-FKIT	\$36.00	Three-pole	Al/Cu #2-14	A6T	Figure 7	600V@10A	GS-41P0-FUSE			\$39.50	
GS-42P0-FKIT	\$38.00					600V@15A	GS-42P0-FUSE	\$33.00			
GS-43P0-FKIT	\$41.50					600V@20A	GS-43P0-FUSE	\$53.00			
GS-45P0-FKIT	\$44.00				600V@30A	GS-45P0-FUSE	\$50.00				
GS-47P5-FKIT	\$53.00				Figure 8	600V@50A	GS-47P5-FUSE	\$60.00			
GS-4010-FKIT	\$91.00					Figure 9	600V@70A	GS-4010-FUSE	\$65.00		
GS-4015-FKIT	\$97.00		600V@90A				GS-4015-FUSE	\$32.00			
GS-4020-FKIT	\$115.00		Cu 2/0-#12		A6T	Figure 10	600V@125A	GS-4020-FUSE	\$65.00		
GS-4025-FKIT	\$115.00						600V@150A	GS-4025-FUSE	\$71.00		
GS-4030-FKIT	\$115.00						600V@175A	GS-4030-FUSE	\$69.00		
GS-4040-FKIT**	\$208.00					Figure 11 **	600V@225A	GS-4040-FUSE	\$166.00		
GS-4050-FKIT**	\$208.00						600V@250A	GS-4050-FUSE	\$162.00		
GS-4060-FKIT**	\$221.00	600V@350A		GS-4060-FUSE			\$174.00				
GS-4075-FKIT**	\$221.00	One-pole	Al/Cu 2/0-#6	Figure 11 **	600V@400A	GS-4075-FUSE	\$170.00				
GS-4100-FKIT**	\$441.00				600V@600A	GS-4100-FUSE	\$385.00				
Figure 12 **					600V@600A						

NOTES:
 * – Single phase 115V fuse kits are for use only with GS1 and GS2 drives.
 ** – Kit includes three single-pole fuse blocks and three fuses.
 † – GS-2010-FKIT and GS-2015-FKIT are no longer available. Please use GS-27P5-FKIT instead.

GS/DURAPULSE Accessories – Fusing

Fuse Specifications for GS2 575V Drives						
GS2 Drive Model	Edison Fuse Block	Fuse Block Type	Fuse Class	Fuse Rating	SCCR	Edison Fuses (10 fuses per pack)
GS2-51P0	BC6033PQ or CHCC3D or CHCC3DI	3-pole or 3-pole modular or 3-pole modular indicating	CC	6A@600V	200 kA	HCLR6
GS2-52P0				10A@600V		HCLR10
GS2-53P0				15A@600V		HCLR15
GS2-55P0				20A@600V		HCLR20
GS2-57P5				30A@600V		HCLR30
GS2-5010						

NOTE:
Refer to the Edison Fuses section of this catalog for pricing, specifications, and dimensions.

Fuse Block Dimensions

Units = inches

Figure 1

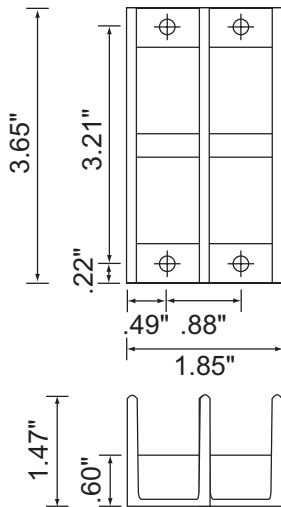

Figure 2

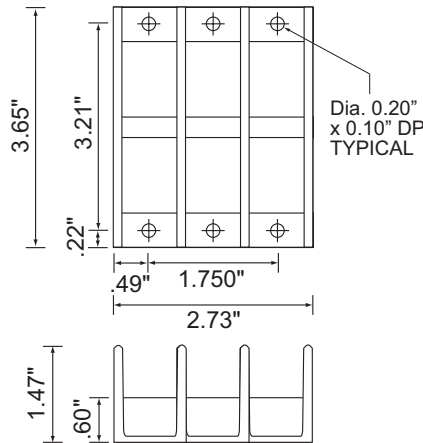

Figure 3

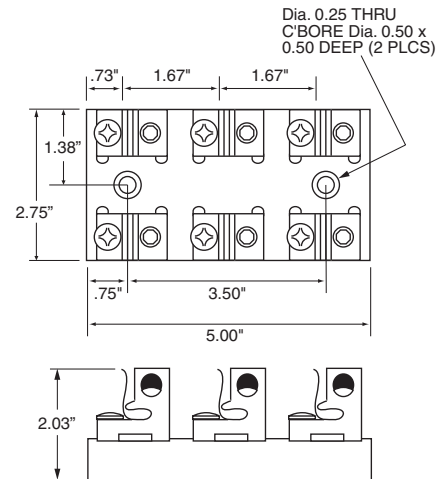

Figure 4

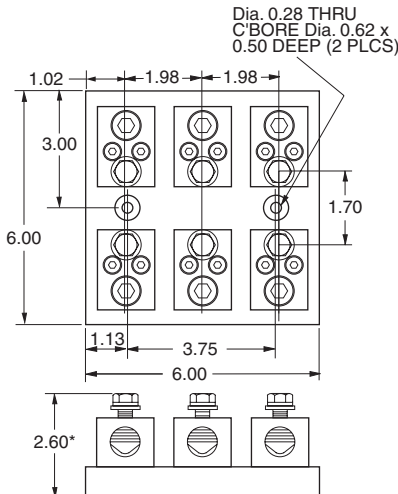

Figure 5

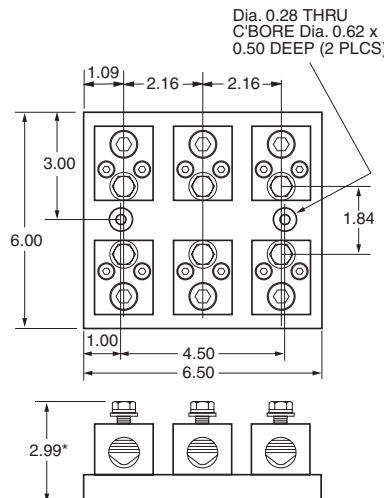
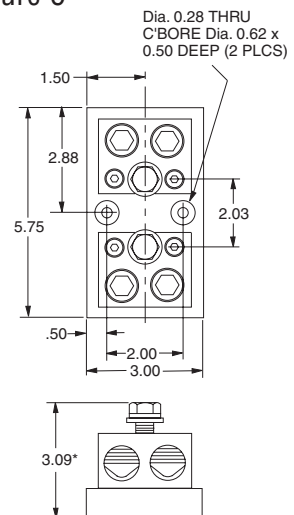

Figure 6



GS/DURAPULSE Accessories – Fusing

Fuse Block Dimensions

Units = inches

Figure 7

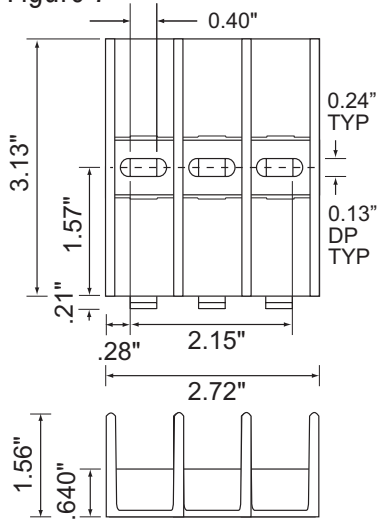

Figure 8

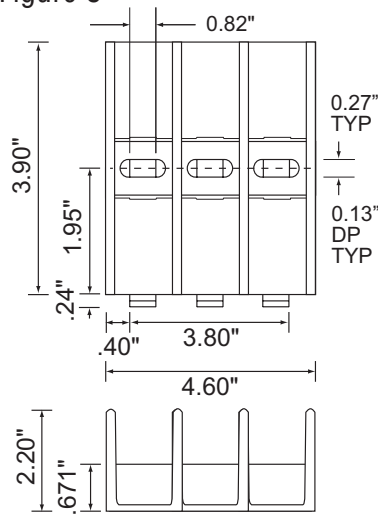

Figure 9

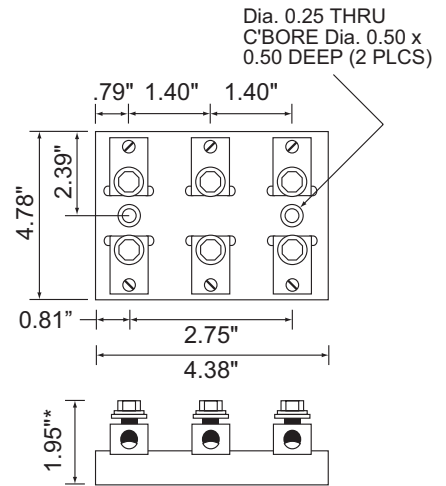

Figure 10

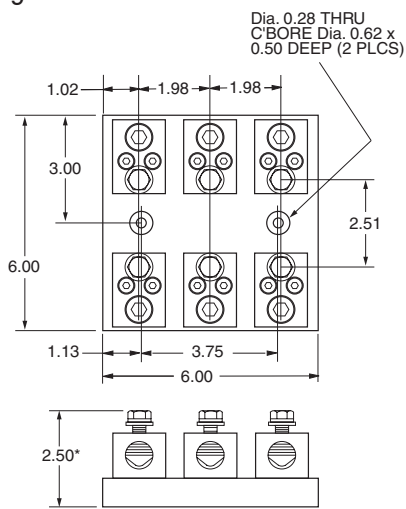

Figure 11

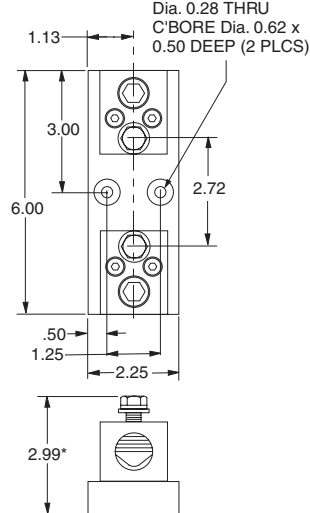
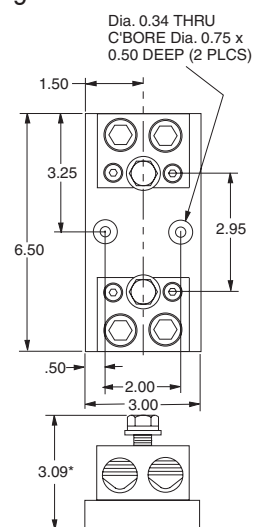

Figure 12



* Height includes nominal fuse blade thickness.

GS/DURAPULSE Accessories

– Ethernet Interface

GS-EDRV100 Overview

The GS-EDRV100 Ethernet interface provides a high-performance Ethernet link between a control system and any GS or DURAPULSE AC drive. The GS-EDRV100 processes signals to and from the drive, mounts on 35mm DIN rail, and connects the drive to an Ethernet hub or PC. It formats drive signals to conform with the Ethernet standard and transmits these signals to the H2-ERM or H4-ERM, Productivity3000, KEPDirect OPC Server, KEPDirect EBC I/O Server, or independent controller with a Modbus TCP/IP driver. This allows for greater connectivity to many control system architectures.

An additional feature is the built-in Web server which allows users to configure and control the drive from any Web browser via the IP address of the GS-EDRV100 card.

Note: The GS-EDRV100 requires an external 24 VDC power supply.

Automatic power shut-down

The GS series drives have a provision for shutting down control or power to the inverter in the event of a communications time-out. This function can be set up through the drive's parameter group 9.

Dimensions: inches[mm]

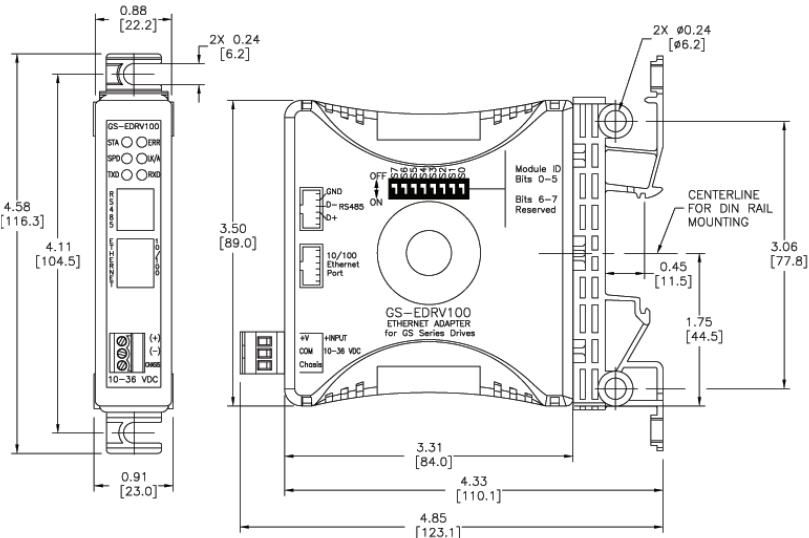

DURAPULSE Drive

DURAPULSE Drive

- LED Indicators**
- STA - Status
- SPD - 100Mbps
- TXD - Transmit
- ERR - Module Error
- LK/A - Link/Active
- RXD - Receive

Serial Port

Ethernet Port

Power Terminals (Class 2 power recommended)

- Positive connection (+) or +10-36VDC
- Negative connection (-) or 0VDC
- Chassis or system ground connection

DIP Switches (under cover)

Module ID Bits 0-5, Bits 6-7 Reserved

GS-EDRV100 Ethernet Adapter for GS Series Drives

Specifications	
Part Number	GS-EDRV100
Price	\$199.00
Approvals	cUL Listed, file number E185989
Input Voltage	10-36 VDC
Input Current	50-220 mA
NOTE: Can be used with all GS/DURApulse series AC drives.	
NOTE: Package includes 2-ft. serial communications cable.	
NOTE: Mounts on 35mm DIN rail.	

GS/DURAPULSE Accessories – Ethernet Interface

GS-EDRV Overview

Note: The GS-EDRV has been superseded by the GS-EDRV100. Use the GS-EDRV100 for all new applications.

The GS-EDRV Ethernet interface provides a high-performance Ethernet link between a control system and any GS or DURAPULSE AC drive. The GS-EDRV processes signals to and from the drive, mounts on a DIN rail, and connects the drive to an Ethernet hub or PC. It formats drive signals to conform with the Ethernet standard and transmits these signals to the H2-ERM or H4-ERM, Productivity3000, KEPDirect OPC Server, KEPDirect EBC I/O Server, or independent controller with a Modbus TCP/IP driver. This allows for greater connectivity to many control system architectures.

An additional feature is the built-in Web server which allows users to configure and control the drive from any Web browser via the IP address of the GS-EDRV card.

Note: The GS-EDRV requires an external 24 VDC power supply.

Automatic power shut-down

The GS series drives have a provision for shutting down control or power to the inverter in the event of a communications time-out. This function can be set up through the drive parameter group 9.

Dip Switches

Communication Ports

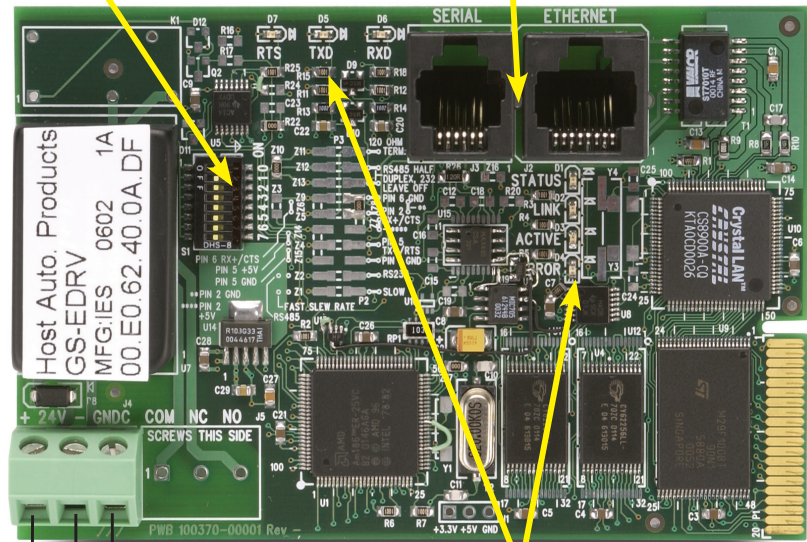

LED Indicators

Power Terminals

- Chassis or system ground connection
- Negative connection (-) or 0VDC
- Positive connection (+) or +24 VDC

Dimensions

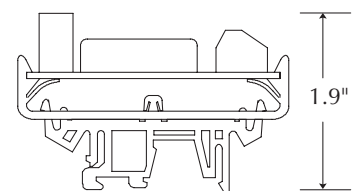
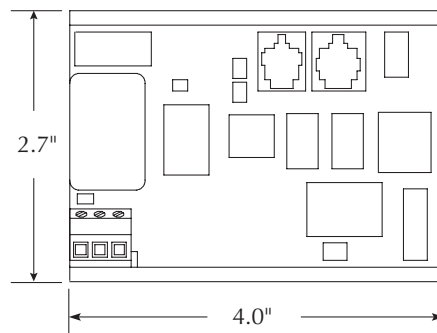

units: inches

Specifications	
Part Number	GS-EDRV
Price	Retired
Input Voltage	10–33 VDC
Input Current	90–135 mA
<i>Can be used with all series GS/DURAPULSE AC drives</i>	

GS/DURAPULSE Accessories – Software

KEPDirect Software Overview

The *KEPDirect* EBC I/O Server and the *KEPDirect* OPC Server are software packages that provide a way to connect your favorite Windows client software to **AUTOMATIONDIRECT** Ethernet I/O through our Ethernet base controllers. It provides GS/DURAPULSE series drive support via the GS-EDRV100 Ethernet interface, as shown in the diagram below. *KEPDirect* allows the user a direct line into the drive parameter group just like an Ethernet field I/O drop. The user can control or monitor from any OPC/DDE compliant third party software. For a complete description of *KEPDirect* software features, go to the Software section of this catalog. *Several application notes specific to the versatility of this software can be found on our web site at www.automationdirect.com.*

KEP Direct Software		
Part Number	Description	Price
PC-KEPOPC	Supports over 1024 GS-EDRV100 or EBC nodes	\$399.00

Can be used with all series GS/DURAPULSE AC drives; Requires GS-EDRV100 Ethernet interface.

CMMS and Condition Monitoring of Drives and Hardware Applications

Condition monitoring is usually the last part of CMMS (Computer Maintenance Management Software) implementation to be explored. It is expensive and difficult to use. Traditionally, the CMMS companies have used custom built data acquisition (DAQ) boards to monitor systems for values like vibration or temperature.

Technologies such as *KEPDirect*, GS/DURAPULSE drives, and Terminator field I/O are perfect matches to allow the user to dispose of expensive proprietary DAQ boards. In addition to the cost savings, the intuitive set-up will reduce implementation.

These will become the standard tools that monitor control loop performance on-line and in real time. These tools enable continuous monitoring of control loops, and instant notification of operational deviations as they occur. Using OPC to tie these systems into CMMS provides tracking and automatic evaluation of your soft and hard assets. It also enables easy tracking of true operational and maintenance costs associated with those assets. Personnel can focus on fixing the cause of the problem, and not just the symptom.

Larger Scale Asset Management Applications

On a larger scale, such as Asset Management Software, there is too much information to directly link to the software (many of them are OPC/DDE compliant). There must be a buffer of some type. Usually this buffer is a SCADA type package that handles distribution of information gathered by condition monitoring field devices. *KEPDirect* and Terminator field I/O can connect as easily to the SCADA software as to any OPC compliant software.

Major OPC Clients Supported

- Rockwell Software RSVIEW32®
- GE's Cimplicity®
- Iconics' Genesis32®
- Cutler Hammer's PanelMate PC Pro
- Think & Do Live!
- Think & Do Studio
- Wonderware's In Touch® and OPCLink®
- Intellution's Fix Dynamics® and OPC Power Tool®
- Siemens' WinCC®
- Kepware's OPC QuickClient
- BizWareDirect's DataNet OPC
- National Instrument's LabVIEW
- National Instrument's Lookout
- Lookout Direct

System Requirements

To run *KEPDirect* EBC I/O Server, your PC must meet the following requirements:

- Pentium CPU, 400 Mhz clock speed
- Windows 98, NT 4.0 SP5, 2000 or XP
- 64 MB free RAM and 10 MB free hard disk space

To run *KEPDirect* OPC Server, your PC must meet the following requirements:

- 2.0 GHz Processor
- Windows 2000 SP4, Server 2003 SP2, XP, Server 2008, Vista Business/Ultimate or 7 Pro/Ultimate
- 1 GB free RAM and 180 MB free hard disk space

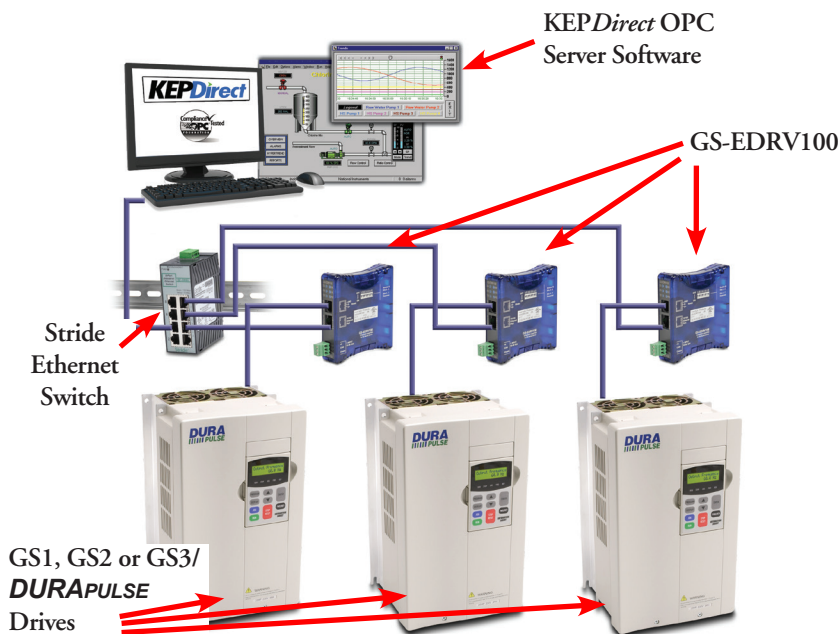

GS/DURAPULSE Accessories – Software



System Requirements

To run GSoft, your PC must meet the following requirements:

- Windows 95, 98, Me, NT, 2000, XP, or Windows 7
- Internet Explorer 4.0 or higher (for HTML help support)
- 24 Mb of available memory
- 8Mb hard drive space
- Available RS-232 serial port (or USB-RS232, USB-485M converters)

- Trend drive operation parameters in real time.
- Maintenance keypad will allow the user to commission the drive from the PC, check rotation, and run a basic cycle.
- Live PID tuning with active tuning control. Take the difficulty out of PID tuning with a real time trend.
- View drive faults.
- OPC client with KEPCON Direct EBC I/O or OPC Server over the Ethernet with the GS-EDRV100 option card
- Have a large system with KEPCON Direct already being used to supply information to your SCADA system? Now program online with drive changes.

Overview

GSoft, the configuration software for the GS/DURAPULSE drives, allows a personal computer to be directly connected to the drives via RS-232 or RS-485 (PC serial port, USB-RS232, USB-485M, or customer supplied converter required). You can perform a variety of functions to allow easy, intuitive, and secure set-up of any application that is required using GSoft.

GSOFT is available as a free download at: <http://support.automationdirect.com/products/gsoft.html>.
(CD can be purchased for \$9.00)

Features

- Create new drive configurations using one of three views:
 - Quick Start - Allows for just the basic set-up to get quick and simple applications up and running ASAP.
 - Detailed - The complete set-up of all parameters in the drive.
 - Schematic Views - Set up the drive using the interactive schematic view. Create a printable cad-like drawing at the same time for future documentation and maintenance-friendly activities.
- Upload/download drive configurations.
- Edit drive configuration.
- Archive/store multiple drive configurations on your PC.

GS/DURAPULSE AC Drive Software		
Part Number	Price	Description
GSOFT *	\$9.00	configuration software CD *
USB-485M	\$51.00	USB to RS-485 converter
GS-232CBL	\$15.00	RS-232 cable
USB-RS232	\$31.00	USB to RS232 converter

* GSOFT can be used with all series GS/DURAPULSE drives; USB-485M or FA-ISOCOM required for GS1 and DURAPULSE drives.
* GSOFT can be downloaded for free: www.automationdirect.com

GSoft offers three software configuration methods

Detailed Configuration

The Detailed Configuration method provides AC drive parameter access in a tabbed dialog format. Detailed Configuration can be used for new or existing configurations.

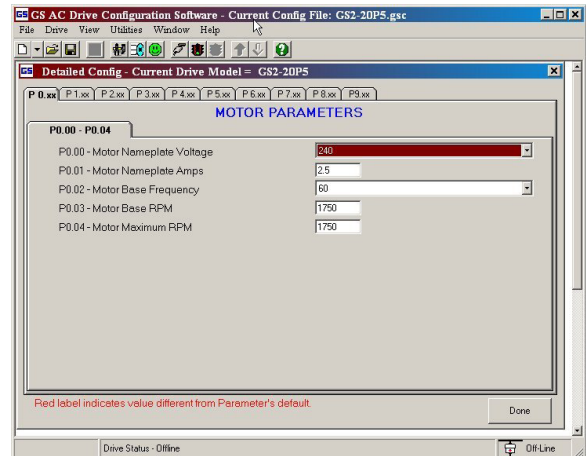

Schematic View Configuration

The Schematic View Configuration method uses a schematic picture of the AC drive and external connections to guide you through the setup of the AC drive. The Schematic View method can be used for new or existing configurations.

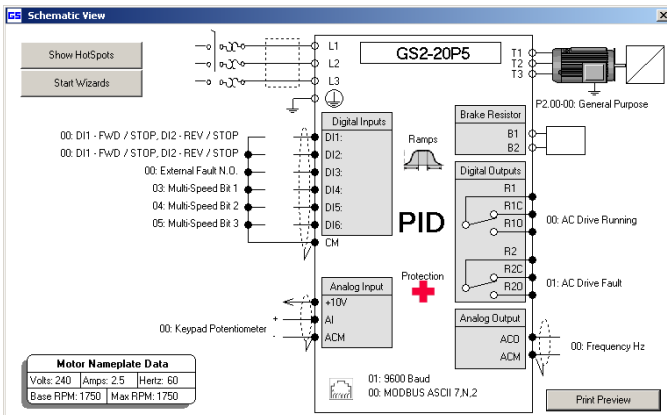

Quick Start Configuration

The Quick Start Configuration method guides you through the most commonly used AC drive parameters. Quick Start Configuration may ONLY be used to create a new configuration. Once created and saved, subsequent editing is done using the Detailed or Schematic View methods.

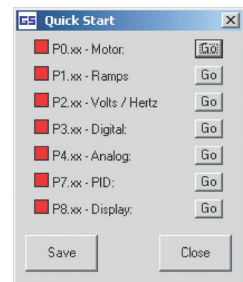

GS/DURAPULSE Accessories – Miscellaneous

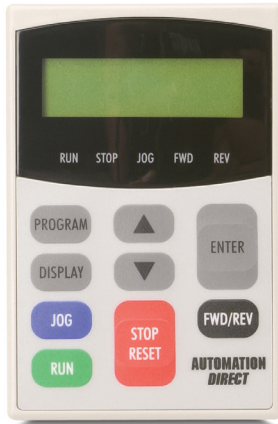

GS3-KPD



GS2-KPD



ZL-CDM-RJ12x4



ZL-CDM-RJ12x10

GS3-BZL

The GS3-BZL Flush Mount Bezel Kit allows remote mounting of the DURAPULSE removable keypad. The Bezel Kit has a Protected Chassis, IP20 enclosure rating. The thickness of the panel will determine required hole dimensions:

GS3-KPD

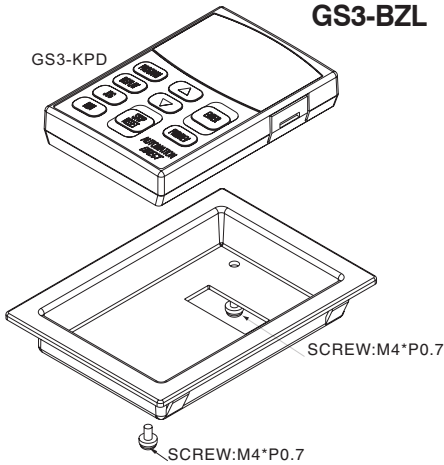

t = 1.0 (.0393) - 1.4 (.0551) t = 1.6 (.629) - 2.0 (.0787) t = 2.2 (.0866) - 3.0 (.1181)

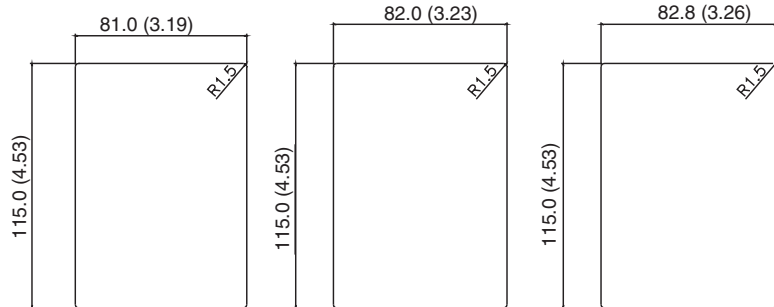

GS-CBL2-1L



GS-CBL2-3L



GS-CBL2-5L

GS/DURAPULSE Drives Miscellaneous Accessories

Part Number	Drive Model	Description	Price
GS-232CBL	GS1, GS2, GS3/DURApulse	Configuration Cable required for GSoft configuration software	\$15.00
GS-CBL2-1L	GS2, GS3/DURApulse	One meter keypad cable (installation screws included)	\$28.50
GS-CBL2-3L	GS2, GS3/DURApulse	Three meter keypad cable (installation screws included)	\$37.50
GS-CBL2-5L	GS2, GS3/DURApulse	Five meter keypad cable (installation screws included)	\$43.50
GS2-KPD	GS2	Spare or replacement keypad for GS2 AC drives	\$37.50
GS3-KPD	GS3/DURApulse	Spare or replacement keypad for DURApulse AC drives; great for maintenance or back-up programs	\$66.00
GS3-BZL	GS3/DURApulse	Flush Mount Bezel Kit for remote mounting of the DURApulse removable keypad	\$13.00
ZL-CDM-RJ12X4	GS1, GS2, GS3/DURApulse	ZIPLink 4-port communication distribution module, 4 RJ12 ports, and 1 screw terminal port	\$18.00
ZL-CDM-RJ12X10	GS1, GS2, GS3/DURApulse	ZIPLink 10-port communication distribution module, 10 RJ12 ports, and 1 screw terminal port	\$22.00

Optional ZipLink serial communication cables available for plug and play connectivity to AutomationDirect PLCs. See the comm cable selection matrix on page-93.

GS/DURAPULSE Accessories

- Miscellaneous

GS2 DIN Rail Adapter

Mounting plate adapter for mounting smaller-frame GS2 drives onto 35mm DIN rail. This adapter will fit all GS2 drives 2HP and below. The adapter will also fit 3HP GS2 drives that are 460V and 575V. Includes adapter, drive mounting screws, and installation instructions.

- RoHS compliant

GS2 DIN Rail Adapter			
Part Number	Price Each	Description	Drive Model (GS2)
GS2-DR02	\$8.00	DIN rail adapter plate for smaller GS2 drives; includes installation instructions & drive mounting screws & nuts [(4) M4-0.7x10mm screws, (2) M4-0.7x22mm screws, (2) M4x0.7 nuts]	GS2-10P2, GS2-10P5, GS2-11P0, GS2-20P5, GS2-21P0, GS2-22P0, GS2-41P0, GS2-42P0, GS2-43P0, GS2-51P0, GS2-52P0, GS2-53P0
<p>GS2-DR02 not required for GS1 drives (which have built-in DIN-rail mounting capability) GS2-DR02 not applicable for: Any GS2 drives not listed in this table, EMI filters mounted between drive and DIN rail adapter (mount filter separately, if required), Any GS3/DURApulse drives.</p>			

GS2-DR02

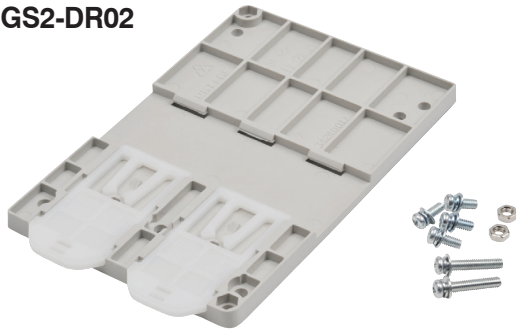

GS2-DR02 Mounting

Screw Torque ($\pm 10\%$):
15 kg•cm [13 lb•in]

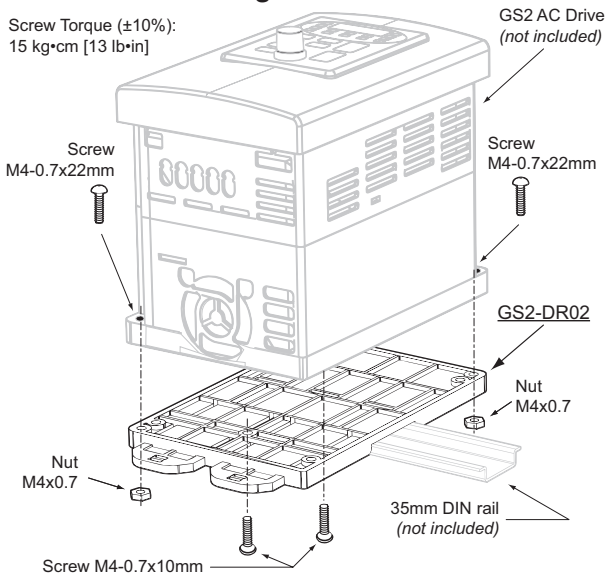

GS2-DR02 Dimensions

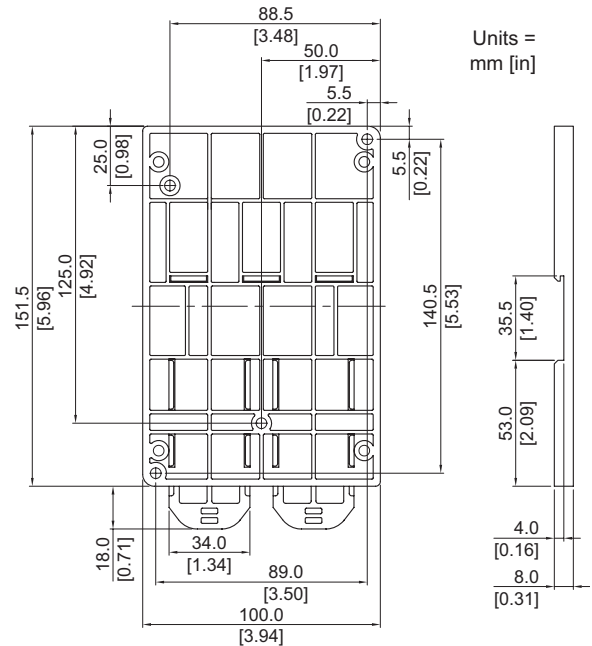

GS/DURAPULSE Accessories – Replacement Parts for DURAPULSE AC Drives

DURAPULSE AC drives 3 hp and larger have built-in cooling fans, and replacement fans are also available. These fans are direct replacements for the internal factory-installed fans.



Fan replacement should only be performed by personnel skilled in the disassembly and repair of variable frequency AC drives.



INSTALLATION INSTRUCTIONS ARE INCLUDED WITH THE FANS.

Replacement Fans for DURAPULSE (GS3 Series) AC Drives					
Part Number ⁽¹⁾	Price	Specifications ⁽²⁾	Fans / Drive ⁽³⁾	GS3 Drive Model ⁽⁴⁾	Drive V / HP
GS-FAN-1	\$24.00	50 mm, 12 VDC, 0.25A	1	GS3-43P0	460 / 3
GS-FAN-2	\$26.00	60 mm, 12 VDC, 0.25A	1	GS3-23P0 GS3-25P0 GS3-45P0	230 / 3 230 / 5 460 / 5
GS-FAN-3	\$26.00	80 mm, 12 VDC, 0.42A	2	GS3-27P5 GS3-2010 GS3-2015 GS3-47P5 GS3-4010 GS3-4015	230 / 7.5 230 / 10 230 / 15 460 / 7.5 460 / 10 460 / 15
GS-FAN-4	\$38.00	92 mm, 24 VDC, 0.30A	2	GS3-2020 GS3-2025 GS3-2030 GS3-4020 GS3-4025 GS3-4030	230 / 20 230 / 25 230 / 30 460 / 20 460 / 25 460 / 30
GS-FAN-5	\$96.00	120 mm, 24 VDC, 1.2A	2	GS3-2040 GS3-2050 GS3-4040 GS3-4050 GS3-4060 GS3-4075 GS3-4100	230 / 40 230 / 50 460 / 40 460 / 50 460 / 60 460 / 75 460 / 100
<p>1) One fan per part number. Includes connectorized electrical cable and installation instructions.</p> <p>2) Fans are replacements for the internal fans in GS3 drives, are dimensionally and electrically equivalent to the originals, and are not intended for other use. Fan electrical loading is included in the input amperage ratings of the drives, and DC voltage is internally provided by the drives.</p> <p>3) Some drives require multiple fans.</p> <p>4) Can be used only with applicable DURAPULSE AC drive.</p>					



Wiring Solutions

Wiring Solutions using the ZIPLink Wiring System

ZIPLinks eliminate the normally tedious process of wiring between devices by utilizing prewired cables and DIN rail mount connector modules. It's as simple as plugging in a cable connector at either end or terminating wires at only one end. Prewired cables keep installation clean and efficient, using half the space at a fraction of the cost of standard terminal blocks. There are several wiring solutions available when using the ZIPLink System ranging from

PLC I/O-to-ZIPLink Connector Modules that are ready for field termination, options for connecting to third party devices, GS, DuraPulse and SureServo Drives, and specialty relay, transorb and communications modules. Pre-printed I/O-specific adhesive label strips for quick marking of ZIPLink modules are provided with ZIPLink cables. See the following solutions to help determine the best ZIPLink system for your application.

Solution 1: DirectLOGIC, CLICK and Productivity3000 I/O Modules to ZIPLink Connector Modules

When looking for quick and easy I/O-to-field termination, a ZIPLink connector module used in conjunction with a prewired ZIPLink cable, consisting of an I/O terminal block at one end and a multi-pin connector at the other end, is the best solution.

Using the PLC I/O Modules to ZIPLink Connector Modules selector tables located in this section,

1. Locate your I/O module/PLC.
2. Select a ZIPLink Module.
3. Select a corresponding ZIPLink Cable.

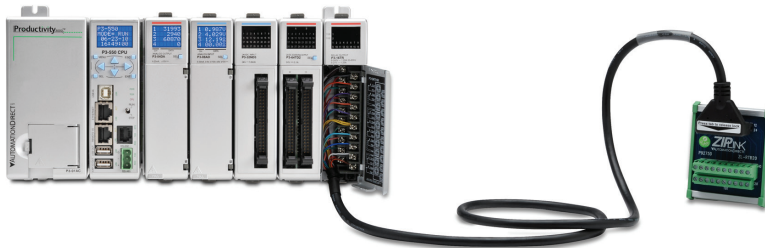

Solution 2: DirectLOGIC, CLICK and Productivity3000 I/O Modules to 3rd Party Devices

When wanting to connect I/O to another device within close proximity of the I/O modules, no extra terminal blocks are necessary when using the ZIPLink Pigtail Cables. ZIPLink Pigtail Cables are prewired to an I/O terminal block with color-coded pigtail with soldered-tip wires on the other end.

Using the I/O Modules to 3rd Party Devices selector tables located in this section,

1. Locate your PLC I/O module.
2. Select a ZIPLink Pigtail Cable that is compatible with your 3rd party device.



Solution 3: GS Series and DURAPULSE Drives Communication Cables

Need to communicate via Modbus RTU to a drive or a network of drives?

ZIPLink cables are available in a wide range of configurations for connecting to PLCs and SureServo, SureStep, Stellar Soft Starter and AC drives. Add a ZIPLink communications module to quickly and easily set up a multi-device network.

Using the Drives Communication selector tables located in this section,

1. Locate your Drive and type of communications.
2. Select a ZIPLink cable and other associated hardware.



Solution 4: Serial Communications Cables

ZIPLink offers communications cables for use with *Direct*LOGIC, CLICK, and Productivity3000 CPUs, that can also be used with other communications devices. Connections include a 6-pin RJ12 or 9-pin, 15-pin and 25-pin D-sub connectors which can be used in conjunction with the RJ12 or D-Sub Feedthrough modules.

Using the Serial Communications Cables selector table located in this section,

1. Locate your connector type
2. Select a cable.



Solution 5: Specialty ZIPLink Modules

For additional application solutions, ZIPLink modules are available in a variety of configurations including stand-alone relays, 24VDC and 120VAC transorb modules, D-sub and RJ12 feedthrough modules, communication port adapter and distribution modules, and SureServo 50-pin I/O interface connection.

Using the ZIPLink Specialty Modules selector table located in this section,

1. Locate the type of application.
2. Select a ZIPLink module.



Solution 6: ZIPLink Connector Modules to 3rd Party Devices

If you need a way to connect your device to terminal blocks without all that wiring time, then our pigtail cables with color-coded soldered-tip wires are a good solution. Used in conjunction with any compatible ZIPLink Connector Modules, a pigtail cable keeps wiring clean and easy and reduces troubleshooting time.

Using the Universal Connector Modules and Pigtail Cables table located in this section,

1. Select module type.
2. Select the number of pins.
3. Select cable.





Motor Controller Communication

Drive / Motor Controller (GS/DURAPulse/SureServo/SureStep/Stellar) ZIPLink Selector							
Drive / Motor Controller		Communications			ZIPLink Cable		
Controller	Comm Port Type	Network/Protocol	Connects to	Comm Port Type	Cable (2 meter length)	Cable Connectors	Other Hardware Required
GS1	RJ12	RS-485 Modbus RTU	DL06 PLCs	Port 2 (HD15)	GS-485HD15-CBL-2	RJ12 to HD15	—
			D2-260 CPU	Port 2 (HD15)	GS-485HD15-CBL-2	RJ12 to HD15	—
			GS-EDRV100	RJ12	GS-EDRV-CBL-2	RJ12 to RJ12	—
			ZL-CDM-RJ12Xxx*	RJ12	GS-485RJ12-CBL-2	RJ12 to RJ12	—
			FA-ISOCON	5-pin Connector	GS-ISOCON-CBL-2	RJ12 to 5-pin plug	—
GS2	RJ12	RS-232 Modbus RTU	CLICK PLCs	Port 2 (RJ12)	GS-RJ12-CBL-2	RJ12 to RJ12	—
			DL05 PLCs	Port 2 (RJ12)			—
			DL06 PLCs	Port 2 (RJ12)			—
			D2-250-1 CPU	Port 2 (HD15)			—
			D2-260 CPU	Port 2 (HD15)			—
			D4-450 CPU	Port 3 (25-pin)			—
		P3-550 CPU	Port 2 (RJ12)	—			
		RS-485 Modbus RTU	DL06 PLCs	Port 2 (HD15)	GS-485HD15-CBL-2	RJ12 to HD15	—
			D2-260 CPU	Port 2 (HD15)	GS-485HD15-CBL-2	RJ12 to HD15	—
			GS-EDRV100	RJ12	GS-EDRV-CBL-2	RJ12 to RJ12	—
ZL-CDM-RJ12Xxx*	RJ12		GS-485RJ12-CBL-2	RJ12 to RJ12	—		
FA-ISOCON	5-pin Connector	GS-ISOCON-CBL-2	RJ12 to 5-pin plug	—			
DuraPulse (GS3)	RJ12	RS-485 Modbus RTU	DL06 PLCs	Port 2 (HD15)	GS-485HD15-CBL-2	RJ12 to HD15	—
			D2-260 CPU	Port 2 (HD15)	GS-485HD15-CBL-2	RJ12 to HD15	—
			GS-EDRV100	RJ12	GS-EDRV-CBL-2	RJ12 to RJ12	—
			ZL-CDM-RJ12Xxx*	RJ12	GS-485RJ12-CBL-2	RJ12 to RJ12	—
			FA-ISOCON	5-pin Connector	GS-ISOCON-CBL-2	RJ12 to 5-pin plug	—
Stellar (Soft Starter) SR44 Series	RJ45**	RS-485 Modbus RTU	DL06 PLCs	Port 2 (HD15)	SR44-485HD15-CBL-2	RJ45 to HD15	SR44-RS485**
			D2-250-1 CPU	Port 2 (HD15)	SR44-485HD15-CBL-2	RJ45 to HD15	
			D2-260 CPU	Port 2 (HD15)	SR44-485HD15-CBL-2	RJ45 to HD15	
			ZL-CDM-RJ12Xxx*	RJ12	SR44-485RJ45-CBL-2	RJ45 to RJ12	
SureServo	IEEE1394 (CN3)	RS-232 Modbus RTU	CLICK PLCs	Port 2 (RJ12)	SVC-232RJ12-CBL-2	6-pin IEEE to RJ12	—
			DL05 PLCs	Port 2 (RJ12)			—
			DL06 PLCs	Port 2 (RJ12)			—
			D2-250-1 CPU	Port 2 (HD15)			—
			D2-260 CPU	Port 2 (HD15)			—
			D4-450 CPU	Port 3 (25-pin)			—
		P3-550 CPU	Port 2 (RJ12)	—			
		RS-485 Modbus RTU	DL06 PLCs	Port 2 (HD15)	SVC-485HD15-CBL-2	6-pin IEEE to HD15	—
			D2-260 CPU	Port 2 (HD15)	SVC-485HD15-CBL-2	6-pin IEEE to HD15	—
			ZL-CDM-RJ12Xxx*	RJ12	SVC-485RJ12-CBL-2	6-pin IEEE to RJ12	—
USB-485M	RJ45		SVC-485CFG-CBL-2	6-pin IEEE to RJ45	—		
SureStep	RJ12	RS-232 ASCII	DL06 PLCs	Port 2 (HD15)	STP-232HD15-CBL-2	HD15-pin to RJ12	—
			D2-250-1 CPU	Port 2 (HD15)			—
			D2-260 CPU (Port2)	Port 2 (HD15)			—
			DL05 PLCs	RJ12	STP-232RJ12-CBL-2	RJ12 to RJ12	—
			CLICK PLCs	RJ12			—
			Do-more PLC	Port 2 (Serial)			—
			Productivity Series	RS-232 Serial			—

* When using the ZL-CDM-RJ12Xxx ZIPLink Communication Distribution Module, replace the lowercase "xx" with the number of RJ12 ports, i.e. "4" for four ports, or "10" for ten ports. (ex: ZL-CDM-RJ12X4 or ZL-CDM-RJ12X10)

** The SR44-RS485 Communications Adapter must be installed for RS-485 communications with the Stellar soft starters.

Hitachi Drives Cross References

To find a suitable replacement for an SJ300 Hitachi drive, use the chart to the right to determine control mode(s) required, and the tables below to determine possible replacement part numbers. Suggested replacements do not necessarily have all control modes of the original, so appropriate drives will be application-dependent. Please call Tech Support if there are any replacement questions.

Drive Series	Volts/Hz	PID	Sensorless Vector	Full Flux Vector
L100	✓	✓		
SJ100	✓	✓	✓	
GS1	✓			
GS2	✓	✓		
DURAPULSE (GS3)	✓	✓	✓	
SJ300	✓	✓	✓	✓

Hitachi SJ300 Cross Reference

Hitachi SJ300 AC Drives			Possible Replacements					
	Part No.	Horsepower	GS1	Price	GS2	Price	DURAPULSE (GS3)	Price
	230V	SJ300-004LFU	0.5 hp	GS1-20P5	\$117.00	GS2-20P5	\$158.00	GS3-21P0 **
SJ300-007LFU		1.0 hp	GS1-21P0	\$134.00	GS2-21P0	\$177.00	GS3-21P0	\$242.00
SJ300-015LFU		2.0 hp	GS1-22P0 *	\$164.00	GS2-22P0	\$251.00	GS3-22P0	\$293.00
SJ300-022LFU		3.0 hp	-	-	GS2-23P0	\$309.00	GS3-23P0	\$347.00
SJ300-037LFU		5.0 hp	-	-	GS2-25P0 *	\$363.00	GS3-25P0 *	\$400.00
SJ300-055LFU		7.5 hp	-	-	GS2-27P5 *	\$465.00	GS3-27P5 *	\$549.00
SJ300-075LFU		10 hp	-	-	-	-	GS3-2010 *	\$698.00
SJ300-110LFU		15 hp	-	-	-	-	GS3-2015 *	\$889.00
SJ300-150LFU		20 hp	-	-	-	-	GS3-2020 *	\$1,104.00
SJ300-185LFU		25 hp	-	-	-	-	GS3-2025 *	\$1,298.00
SJ300-220LFU		30 hp	-	-	-	-	GS3-2030 *	\$1,486.00
460V	SJ300-007HFU	1.0 hp	-	-	GS2-41P0 *	\$261.00	GS3-41P0 *	\$323.00
	SJ300-015HFU	2.0 hp	-	-	GS2-42P0 *	\$303.00	GS3-42P0 *	\$360.00
	SJ300-022HFU	3.0 hp	-	-	GS2-43P0 *	\$357.00	GS3-43P0 *	\$385.00
	SJ300-040HFU	5.0 hp	-	-	GS2-45P0 *	\$410.00	GS3-45P0 *	\$427.00
	SJ300-055HFU	7.5 hp	-	-	GS2-47P5 *	\$586.00	GS3-47P5 *	\$613.00
	SJ300-075HFU	10 hp	-	-	GS2-4010 *	\$725.00	GS3-4010 *	\$734.00
	SJ300-110HFU	15 hp	-	-	-	-	GS3-4015 *	\$957.00
	SJ300-150HFU	20 hp	-	-	-	-	GS3-4020 *	\$1,165.00
	SJ300-185HFU	25 hp	-	-	-	-	GS3-4025 *	\$1,383.00
	SJ300-220HFU	30 hp	-	-	-	-	GS3-4030 *	\$1,570.00

Notes: Replacement drives do not necessarily have the same physical dimensions, mounting hole patterns or wiring terminal arrangements.

* All SJ300 drives are specified for use with 3-phase power (but can be installed in single-phase applications). Replacement drive requires 3-phase power. Ensure that the existing SJ application uses 3-phase input power, or that 3-phase power is available.

** Replacement drive is higher horsepower than existing drive. Output power of new drive can be parameter-limited to the smaller horsepower.

Hitachi Drives Cross References

To find a suitable replacement for an L100 or SJ100 Hitachi drive, use the chart to the right to determine control mode(s) required, and the tables below to determine possible replacement part numbers. Suggested replacements do not necessarily have all control modes of the original, so appropriate drives will be application-dependent. Please call Tech Support if there are any replacement questions.

Drive Series	Volts/Hz	PID	Sensorless Vector	Full Flux Vector
L100	✓	✓		
SJ100	✓	✓	✓	
GS1	✓			
GS2	✓	✓		
DURAPULSE	✓	✓	✓	
SJ300	✓	✓	✓	✓

Hitachi L100 Cross Reference

Hitachi L100 AC Drives			Possible Replacements					
	Part No.	Horsepower	GS1	Price	GS2	Price	DURAPULSE	Price
230V	L100-002NFU	0.25 hp	GS1-20P2	\$113.00	GS2-20P5 **	\$158.00	GS3-21P0 **	\$242.00
	L100-004NFU	0.5 hp	GS1-20P5	\$117.00	GS2-20P5	\$158.00	GS3-21P0 **	\$242.00
	L100-007NFU	1.0 hp	GS1-21P0	\$134.00	GS2-21P0	\$177.00	GS3-21P0	\$242.00
	L100-015NFU	2.0 hp	GS1-22P0 *	\$164.00	GS2-22P0	\$251.00	GS3-22P0	\$293.00
	L100-022NFU	3.0 hp	–	–	GS2-23P0	\$309.00	GS3-23P0	\$347.00
	L100-037LFU	5.0 hp	–	–	GS2-25P0 *	\$363.00	GS3-25P0 *	\$400.00
	L100-055LFU	7.5 hp	–	–	GS2-27P5 *	\$465.00	GS3-27P5 *	\$549.00
	L100-075LFU	10 hp	–	–	–	–	GS3-2010 *	\$698.00
460V	L100-004HFU	0.5 hp	–	–	GS2-41P0 * **	\$261.00	GS3-41P0 * **	\$323.00
	L100-007HFU	1.0 hp	–	–	GS2-41P0 *	\$261.00	GS3-41P0 *	\$323.00
	L100-015HFU	2.0 hp	–	–	GS2-42P0 *	\$303.00	GS3-42P0 *	\$360.00
	L100-022HFU	3.0 hp	–	–	GS2-43P0 *	\$357.00	GS3-43P0 *	\$385.00
	L100-040HFU	5.0 hp	–	–	GS2-45P0 *	\$410.00	GS3-45P0 *	\$427.00
	L100-055HFU	7.5 hp	–	–	GS2-47P5 *	\$586.00	GS3-47P5 *	\$613.00
	L100-075HFU	10 hp	–	–	GS2-4010 *	\$725.00	GS3-4010 *	\$734.00

Notes: Replacement drives do not necessarily have the same physical dimensions, mounting hole patterns or wiring terminal arrangements.
 * = Replacement drive requires 3-phase input power. Ensure that the existing application uses 3-phase input power, or that 3-phase power is available.
 ** = Replacement drive is higher horsepower than existing drive. Output power of new drive can be parameter-limited to the smaller horsepower.

Hitachi SJ100 Cross Reference

Hitachi SJ100 AC Drives			Possible Replacements					
	Part No.	Horsepower	GS1	Price	GS2	Price	DURAPULSE	Price
230V	SJ100-002NFU	0.25 hp	GS1-20P2	\$113.00	GS2-20P5 **	\$158.00	GS3-21P0 **	\$242.00
	SJ100-004NFU	0.5 hp	GS1-20P5	\$117.00	GS2-20P5	\$158.00	GS3-21P0 **	\$242.00
	SJ100-007NFU	1.0 hp	GS1-21P0	\$134.00	GS2-21P0	\$177.00	GS3-21P0	\$242.00
	SJ100-015NFU	2.0 hp	GS1-22P0 *	\$164.00	GS2-22P0	\$251.00	GS3-22P0	\$293.00
	SJ100-022NFU	3.0 hp	–	–	GS2-23P0	\$309.00	GS3-23P0	\$347.00
	SJ100-037LFU	5.0 hp	–	–	GS2-25P0 *	\$363.00	GS3-25P0 *	\$400.00
	SJ100-055LFU	7.5 hp	–	–	GS2-27P5 *	\$465.00	GS3-27P5 *	\$549.00
	SJ100-075LFU	10 hp	–	–	–	–	GS3-2010 *	\$698.00
460V	SJ100-004HFU	0.5 hp	–	–	GS2-41P0 * **	\$261.00	GS3-41P0 * **	\$323.00
	SJ100-007HFU	1.0 hp	–	–	GS2-41P0 *	\$261.00	GS3-41P0 *	\$323.00
	SJ100-015HFU	2.0 hp	–	–	GS2-42P0 *	\$303.00	GS3-42P0 *	\$360.00
	SJ100-022HFU	3.0 hp	–	–	GS2-43P0 *	\$357.00	GS3-43P0 *	\$385.00
	SJ100-040HFU	5.0 hp	–	–	GS2-45P0 *	\$410.00	GS3-45P0 *	\$427.00
	SJ100-055HFU	7.5 hp	–	–	GS2-47P5 *	\$586.00	GS3-47P5 *	\$613.00
	SJ100-075HFU	10 hp	–	–	GS2-4010 *	\$725.00	GS3-4010 *	\$734.00

Notes: Replacement drives do not necessarily have the same physical dimensions, mounting hole patterns or wiring terminal arrangements.
 * = Replacement drive requires 3-phase input power. Ensure that the existing application uses 3-phase input power, or that 3-phase power is available.
 ** = Replacement drive is higher horsepower than existing drive. Output power of new drive can be parameter-limited to the smaller horsepower.



IRONHORSE®

GSD Series DC Drives

Ironhorse DC drives that can accommodate DC motors
1/50HP @ 12VDC up to 3HP @ 240VAC

GSD1 Series

- Low Voltage PWM
- 12/24/36/48 VDC input
- Up to 20A output current



GSD1-48-10C



GSD1-48-10N4X



GSD1-48-20C

GSD3 Series

- Small, compact
- 12/24VAC, 120/240VAC input
- Up to 3A output current



GSD3-240-2CJ



GSD3-240-2CL



GSD3-240-3N4



GSD3-24A-2CJ



GSD3-24A-2CL



GSD3-24A-3N4

GSD4 Series

- Economical, general purpose
- 24/36VAC, 120/240VAC input
- Up to 10A output current



GSD4-240-10N4X



GSD4-240-1C



GSD4-240-5C



GSD4-24A-5C

GSD5 Series

- General purpose, many enclosed options
- 120/240VAC input
- Up to 10.8A output current



GSD5-240-10C



GSD5-240-10N4



GSD5-240-10N4-A



GSD5-240-10N4-R



GSD5-240-10N4-V

GSD6 Series

- Full featured, up to 3HP
- 120/240VAC input
- Up to 15A output current



GSD6-240-15C

GSDA-DP

Digital Potentiometer:

- Provides speed reference to drives
- Configurable for any unit
- Scalable, repeatable, simple
- Easy for operators to set precisely



GSD7 Series

- Reversing
- 120 or 240VAC input
- Up to 10A output current



GSD7-120-10CR30



GSD7-120-1CR3



GSD7-120-1CR30



GSD7-120-5CR3



GSD7-240-10CR30



GSD7-240-1CR3



GSD7-240-5CR3

Company Information

Drives

Soft Starters

Motors

Power Transmission

Motion: Servos and Steppers

Motor Controls

Sensors: Proximity

Sensors: Photoelectric

Sensors: Encoders

Sensors: Limit Switches

Sensors: Current

Sensors: Pressure

Sensors: Temperature

Sensors: Level

Sensors: Flow

Pushbuttons and Lights

Stacklights

Signal Devices

Process

Relays and Timers

Pneumatics: Air Prep

Pneumatics: Directional Control Valves

Pneumatics: Cylinders

Pneumatics: Tubing

Pneumatics: Air Fittings

Appendix Book 2

Terms and Conditions

Why choose a DC drive?

DC motors and drives provide several advantages and benefits over AC-powered devices:

- Inexpensive – DC drives are typically less expensive than AC drives
- Low speed performance – DC drives and motors provide excellent low speed control and stability
- Low speed power – DC motors provide exceptional low speed torque and power
- Simple – our DC drives are typically configured with potentiometers – no parameters or programming needed

Choose the DC drive you need below

Frame	Input Voltage	Amps	Motor HP	Part #	
Enclosed	12/24/36/48VDC	10	1/50 - 1/2	GSD1-48-10N4X	
	12/24VAC	3	1/50-1/25 (12V); 1/25-1/12 (24V)	GSD3-24A-3N4	
	120/240VAC	3	1/50-1/3 (90V); 1/25 - 2/3 (180V)	GSD3-240-3N4	
		10	1/8-1 (90V); 1/4-2 (180V)	GSD4-240-10N4X	
		10	1/8 - 1 (90V); 1/4 - 2 (180V)	GSD5-240-10N4	
		10	1/8 - 1 (90V); 1/4 - 2 (180V)	GSD5-240-10N4-R	
		10	1/8 - 1 (90V); 1/4 - 2 (180V)	GSD5-240-10N4-A	
		10	1/8 - 1 (90V); 1/4 - 2 (180V)	GSD5-240-10N4-V	
Open Frame	12/24/36/48VDC	10	1/50 - 1/2	GSD1-48-10C	
	12/24/36/48VDC	20	1/50 - 1	GSD1-48-20C	
	12/24VAC	2	1/50-1/40 (12V); 1/25-1/20 (24V)	GSD3-24A-2CL	
		2	1/50-1/40 (12V); 1/25-1/20 (24V)	GSD3-24A-2CJ	
	24/36VAC	.15 - 5.5	1/50-1/6	GSD4-24A-5C	
	120/240VAC	1.2	1/50-1/8 (90V); 1/25-1/4 (180V)	GSD4-240-1C	
		15	1/8-1.5 (90V); 1/4-3 (180V)	GSD6-240-15C	
		2	1/50-1/6 (90V); 1/25-1/3 (180V)	GSD3-240-2CL	
		2	1/50-1/6 (90V); 1/25-1/3 (180V)	GSD3-240-2CJ	
		5.5	1/8-1/2 (90V); 1/4-1(180V)	GSD4-240-5C	
		10	1/8 - 1 (90V); 1/4 - 2 (180V)	GSD5-240-10C	
	Auto Reversing	120VAC	1.2	1/15 to 1/8	GSD7-120-1CR3
			5.5	1/8 to 1/2	GSD7-120-5CR3
			1.2	1/15 to 1/8	GSD7-120-1CR30
			10	1/8 to 1	GSD7-120-10CR30
		240VAC	1.2	1/25 to 1/4	GSD7-240-1CR3
5.5			1/8 to 1	GSD7-240-5CR3	
		10	1/4 to 2	GSD7-240-10CR30	



money-back
30
day
guarantee



www.automationdirect.com
BUY
ONLINE



Order Today, Ships Today

IronHorse GSD Series DC Drives

GSD Series DC Drives Overview and Selection Guide



GSD DC Drives – Series Comparisons						
Series	GSD1	GSD3	GSD4	GSD5	GSD6	GSD7
Package Configurations Available	open frame NEMA 4X	open frame NEMA 4	open frame NEMA 4X	open frame NEMA 4/12	open frame	open frame
Power Quality Form Factor	1.05	1.4				
Input Voltages	12/24/36/48 VDC	12/24 VAC 120/240 VAC	24/36 VAC 120/240 VAC	120/240 VAC	115/230 VAC	120 VAC 240 VAC
Output Voltages	0–12 VDC 0–24/36 VDC 0–12/24/36/48 VDC	0–12/24 VDC 0–90/180 VDC	0–24/36 VDC 0–90/180 VDC	0–90/180 VDC	0–90/180 VDC	0–90/180 VDC
Shunt Field Voltages & (Currents)	–	10/20 VDC 100/200 VDC (0.75–1A)	20/30 VDC 100/200 VDC (0.5–1A)	100/200 VDC (1A)	100/200 VDC (1.5A)	100/200 VDC (1A)
Motor Ratings (hp)	1/50 – 1 hp	1/50 – 2/3 hp	1/50 – 2 hp	1/8 – 2 hp	1/8 – 3 hp	1/50 – 2 hp
Max Output Current (continuous)	10–20A (DC)	0.15–3A (DC)	1.2–10A (DC)	0.15–10.8A (DC)	15A (DC)	0.5–10A (DC)
Current Overload Capacity	150% for 60s	200% for 60s	200% for 60s	150% for 60s	200% for 60s	200% for 60s
Current Limit	adjustable 0–200%	none	adjustable 1–2.5A (DC) 1–15A (DC)	adjustable 1–15A (DC)	adjustable 2–30A (DC)	adjustable 0.3–18A (DC)
Transient Protection	none	Metal Oxide Varistor (MOV)				
I.R. Compensation	adjustable	adjustable	adjustable	adjustable	adjustable	adjustable
Speed Adjustment	5k Ω pot or 0–10VDC input signal	5k Ω pot	5k Ω pot or 0–5/10/250 VDC or 4–20mA input signal	5k Ω pot or 0–10 VDC input signal	5k Ω pot	5k Ω pot or 0–10 VDC input signal
Speed Range	30:1	25:1	50:1	50:1	50:1	50:1
Speed Regulation	±1% of base speed					
Maximum Speed	adjustable 50–100%	adjustable 40–120%	adjustable 60–100%	adjustable 66–110%	adjustable 60–120%	adjustable 60–110%
Minimum Speed	adjustable 0–30%					
Acceleration	adjustable 0–10s	0.5s (fixed)	0.5s (fixed)	adjustable 0.5–8s	adjustable 0.3–12s	0.5s (fixed)
Deceleration	0.5s (fixed)	n/a (follows ramp of the reference)	adjustable 0.5–8s	adjustable 0.06–80s	adjustable 0.6–12s	0.5s (fixed)
Plugging* / Dynamic Braking	no					yes
Operating Temperature	-10–45 °C [14–113 °F]	-10–45 °C [14–113 °F] -10–40 °C [14–104 °F]	-10–45 °C [14–113 °F] -10–40 °C [14–104 °F]	-10–45 °C [14–113 °F]	-10–45 °C [14–113 °F]	-10–45 °C [14–113 °F]

* Plugging is a method of rapidly changing motor direction by reversing motor armature polarity, while the motor is still running.

GSD1 Series DC Drives

GSD1 Introduction



GSD1-48-10N4X



GSD1-48-xxC

GSD1 Series DC Drives	
12VDC @ 10A	1/50 – 1/8 hp motor
24VDC @ 10A	1/50 – 1/4 hp motor
36VDC @ 10A	1/50 – 3/8 hp motor
48VDC @ 10A	1/50 – 1/2 hp motor
12VDC @ 20A	1/50 – 1/4 hp motor
24VDC @ 20A	1/50 – 1/2 hp motor
36VDC @ 20A	1/50 – 3/4 hp motor
48VDC @ 20A	1/50 – 1 hp motor

Overview

IronHorse GSD1 series DC drives are high-performance Pulse-Width-Modulated (PWM) controllers for 12 to 48 volt equipment providing smooth control with high-efficiency operation.

The advanced design permits a substantial increase in equipment running time between charges over conventional techniques.

Features include adjustable maximum speed, minimum speed, current limit, I.R. compensation, and acceleration. The adjustable current-limit feature protects the control, battery, and motor from sustained overloads.

GSD1 series DC drives are available in open-frame and NEMA 4X enclosed styles, and all come standard with a speed pot, knob, and dial plate.

GSD1 series DC drives are available in 10A and 20A versions. A jumper on the drive selects 12, 24, 36 or 48V operating voltage.

Features

- Provides smooth variable speed capability for mobile equipment
- Automatic compensation holds motor speed steady even if the load varies or battery voltage declines.
- Speed regulation is $\pm 1\%$ of base speed
- Adjustable maximum speed
- Adjustable minimum speed
- Adjustable IR compensation
- Adjustable current limit
- Adjustable acceleration speed
- 5k Ω speed pot with leads, knob and dial included
- Speed adjustment using 5k Ω speed pot or optional 0–10 VDC analog input signal
- Inhibit terminal permits optional start-stop without breaking battery / power line

Accessories

- Replacement speed potentiometer kit
- Digital speed potentiometer

Detailed descriptions and specifications for GSD accessories are available in the “GSD Series DC Drives Accessories” section.

Typical Applications

- Auger feeders
- Automated door actuators
- Commercial cooking equipment
- Commercial lift
- Food production
- Industrial pumping systems
- Measurement instruments
- Miniature lathes and mills
- Packaging / material-handling equipment
- Printing and labeling machines
- Small shop machine tools
- Spray / print reciprocating head

GSD1 Series DC Drives

GSD1 Selection and Specifications

GSD1 Series DC Drives – Selection & Specifications			
Model	GSD1-48-10C	GSD1-48-10N4X	GSD1-48-20C
Price	\$125.00	\$230.00	\$185.00
Package Configuration	open frame	NEMA 4X	open frame
Power Quality Form Factor	1.05		
Input Voltage **	12/24/36/48 VDC ±15% (jumper selectable)		
Output Voltage	0–12/24/36/48 VDC		
Motor Rating (hp)	1/50 – 1/2		1/50 – 1
Output Current (continuous)	10A (DC)		20A (DC)
Current Overload Capacity	200% for 10s; 150% for 60s		
Current Limit	adjustable to 200% of motor Full Load Current, up to 200% of control current rating		
Speed Adjustment	5k Ω potentiometer or 0–10 VDC input signal		
Speed Range	30:1		
Speed Regulation	1% of base speed via adjustable IR compensation trim pot		
Maximum Speed	adjustable from 50% to 100% of base speed		
Minimum Speed	0–30% of adjustable maximum speed		
Acceleration	adjustable from 0–10s		
Deceleration	0.5s (non-adjustable)		
Dynamic Braking	no		
Plugging Capability ***	no		
Internal Operating Frequency	18kHz		
Power Connections (P1)	Euro-style terminal block (14–28 AWG)		Euro-style terminal block (10–14 AWG)
Signal Connections (P2)	Euro-style terminal block (14–28 AWG)		
External Fusing Required	DC-rated @ 150% motor Full Load Current (up to 150% Continuous Output Current rating of drive)		
Operating Temperature	-30 to 65°C [-22 to 140°F] for Chassis -15 to 60°C [5 to 140°F] for Enclosed		
Thermal Protection	none		
Mounting Orientation	Can be mounted in any orientation		
Corrosive Gases	NOT compatible with any corrosive gases		
Package Configuration	Black anodized aluminum extrusion		
Weight	8oz [227g]	40oz [1049g]	8oz [227g]
Agency Approvals	RoHS		
Optional Accessories *			
Replacement Potentiometer	GSDA-5K		
Digital Potentiometer	GSDA-DP		
<p>* For accessories details, refer to the "GSD Series DC Drives Accessories" section. ** Input power supply must not exceed recommended voltage, or it may damage the GSD1 drive. Linear power supply can be sized per drive voltage and motor full load current. Switched power supply should be sized per drive voltage and double the motor full load current. *** Plugging is a method of rapidly changing motor direction by reversing motor armature polarity, while the motor is still running.</p>			

GSD1 Series DC Drives

GSD1 Wiring Diagrams

GSD1-48-xxC Basic Wiring Diagram – (refer to User Manual for more detailed wiring information)

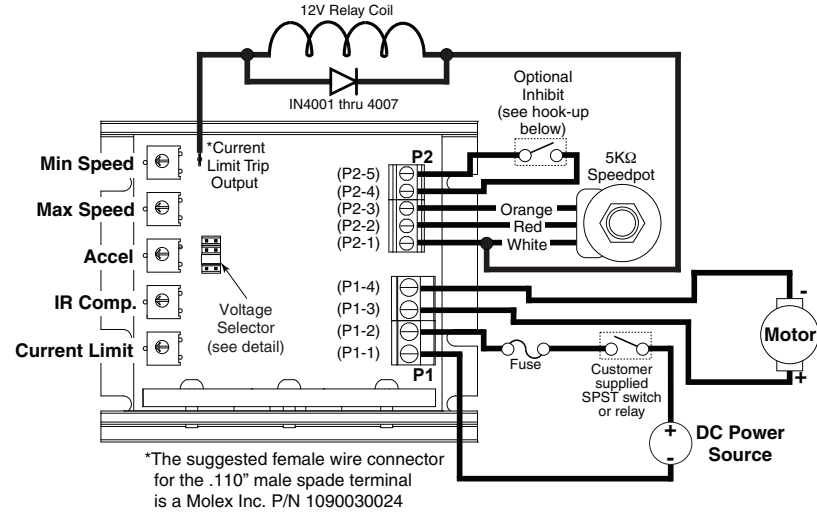

GSD1 Series Terminals		
Terminal Number	Description	Terminal Marking
P1-1	- Battery	(-B)
P1-2	+ Battery	(+B)
P1-3	+ Armature	(+A)
P1-4	- Armature	(-A)
P2-1	Potentiometer High	(HI)
P2-2	Potentiometer Wiper	(WP)
P2-3	Potentiometer Low	(LO)
P2-4	Common	(COM)
P2-5	Inhibit	(INH)

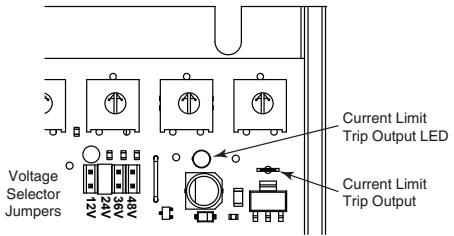

GSD1-48-10N4X Basic Wiring Diagram – (refer to User Manual for more detailed wiring information)

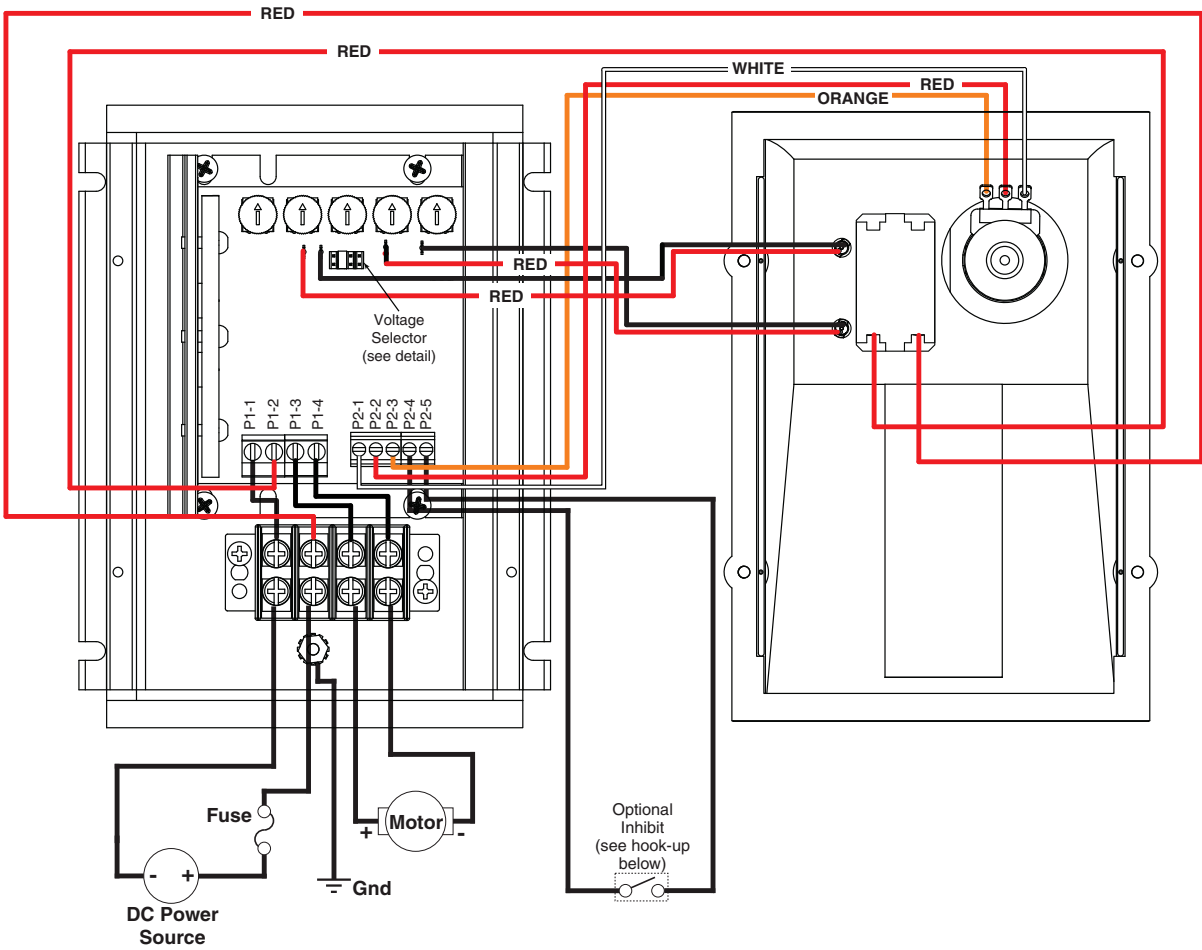

GSD1 Series DC Drives

GSD1 Dimensions – dimensions = in [mm]

GSD1-48-xxC Dimensions

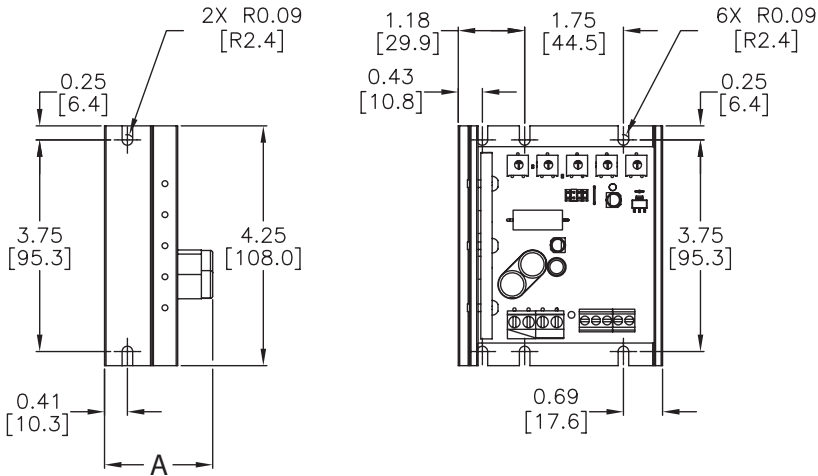

Model	A
GSD1-48-10C	1.70 [43.1]
GSD1-48-20C	1.92 [48.7]

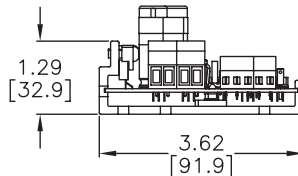

GSD1-48-10N4X Dimensions

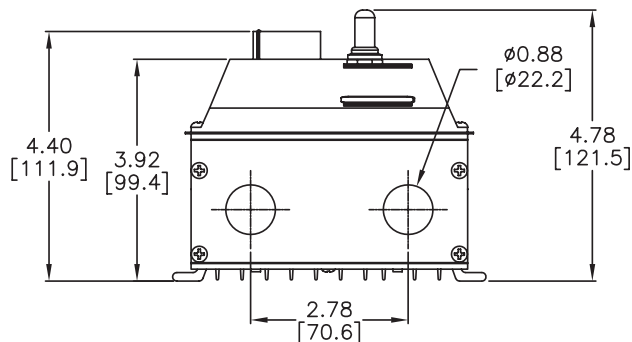
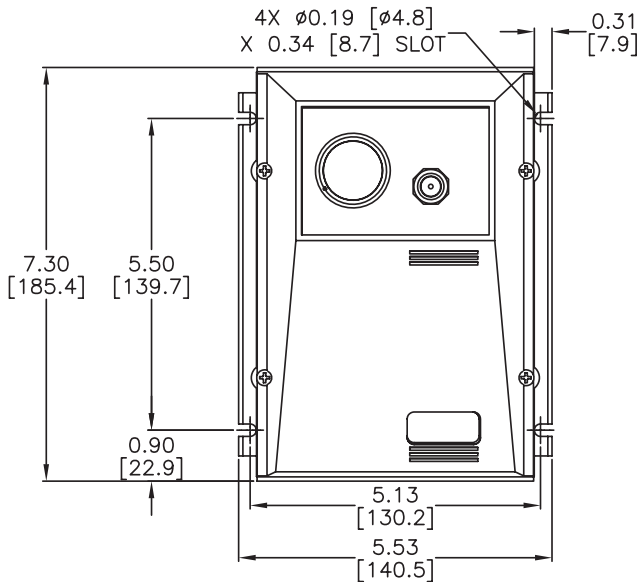

GSD3 Series DC Drives

GSD3 Introduction

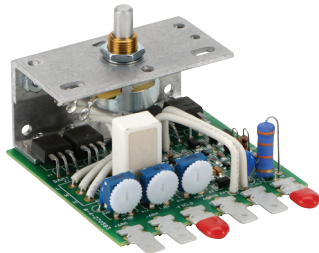

GSD3-xxx-2CJ

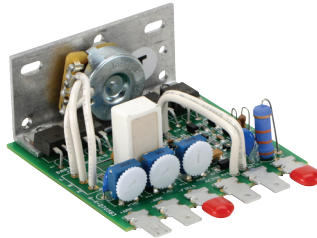

GSD3-xxx-2CL



GSD3-24x-3N4

GSD3 Series DC Drives	
Motor Rating Range @ 12/24 VAC_{IN}	1/50 – 1/12 hp
Motor Rating Range @ 120/240 VAC_{IN}	1/50 – 2/3 hp

Overview

IronHorse GSD3 series DC drives are general-purpose, economical variable-speed controllers for small DC and universal motor applications.

Models are offered with dual input voltages of 12/24 VAC or 120/240 VAC with a DC output current rating of 2 Amps, adjustable trim pot settings, and quick-connect terminal pins.

GSD3 series DC drives are available in two compact panel-mount styles – open-frame and NEMA 4 enclosed.

Features

- Dual input voltage models of 12/24 VAC or 120/240 VAC
- Full-wave bridge power supply
- Adjustable minimum speed
- Adjustable maximum speed
- Adjustable IR compensation
- Fixed acceleration (0.5 seconds)
- 5kΩ speed potentiometer with leads, knob and dial included
- 25:1 speed range
- 1% speed regulation
- Shunt field supply provided (1 Amp max):
 - 10V for 12VAC; 20V for 24VAC input,
 - 100V for 120VAC; 200V for 240VAC input
- Overload capacity of 200% for one minute
- Transient voltage protection
- Power on/off switch (enclosed models)
- AC line fuse (120–240 VAC NEMA 4 only)

Accessories

- Replacement speed potentiometer kit
- Detailed descriptions and specifications for GSD accessories are available in the “GSD Series DC Drives Accessories” section.**

Typical Applications

- Auger feeders
- Automated door actuators
- Commercial cooking equipment
- Commercial lift
- Food production
- Industrial pumping systems
- Measurement instruments
- Miniature lathes and mills
- Packaging / material-handling equipment
- PLC-controlled reversing
- Printing and labeling machines
- Small shop machine tools
- Spray / print reciprocating head

GSD3 Series DC Drives

GSD3 Selection and Specifications

GSD3 Series DC Drives – Selection & Specifications						
Model	GSD3-24A-2CJ	GSD3-24A-2CL	GSD3-24A-3N4	GSD3-240-2CJ	GSD3-240-2CL	GSD3-240-3N4
Price	\$62.00	\$62.00	\$119.00	\$59.00	\$60.00	\$114.00
Package Configuration	open frame		NEMA 4	open frame		NEMA 4
Power Quality Form Factor	1.4					
Input Voltage	12/24 VAC ±10% @ 50/60 Hz			120/240 VAC ±10% @ 50/60 Hz		
Output Voltage	0–12 or 0–24 VDC			0–90 or 0–180 VDC		
Shunt Field Voltage & Current	10 VDC @ 12 VAC 20 VDC @ 24 VAC (1A max)	10 VDC @ 12 VAC 20 VDC @ 24 VAC (0.75A max)	100 VDC @ 120 VAC 200 VDC @ 240 VAC (1A max)	100 VDC @ 120 VAC 200 VDC @ 240 VAC (0.75A max)		
Motor Rating (hp)	1/50 – 1/40 @ 11V 1/25 – 1/20 @ 22V	1/50 – 1/25 @ 11V 1/25 – 1/12 @ 22V	1/50 – 1/6 @ 90V 1/25 – 1/3 @ 180V	1/50 – 1/3 @ 90V 1/25 – 2/3 @ 180V		
Output Current (continuous)	150 mA to 2A (DC)	150 mA to 3A (DC)	150 mA to 2A (DC)	150 mA to 3A (DC)		
Current Overload Capacity	200% for 60s					
Current Limit	none					
Transient Protection	Metal Oxide Varistor (MOV)					
I.R. Compensation	adjustable – full range					
Speed Adjustment	5kΩ potentiometer					
Speed Range	25:1					
Speed Regulation	±1% of base speed					
Maximum Speed	adjustable from 40% to 120% of base speed					
Minimum Speed	adjustable from 0% to 30% of maximum speed					
Acceleration	0.5s (fixed)					
Deceleration	n/a (follows the ramp of the reference)					
Dynamic Braking	no					
Plugging Capability **	no					
Electrical Connections	spade-connector lugs					
External Fusing Required	Bussman ABC or Littelfuse 314 series ceramic fuses or equivalent GSD3-240-3N4 includes internal fusing adequate for 120 VAC line and neutral inputs Refer to wiring diagrams for external fusing requirements for other wiring configurations					
Operating Temperature	-10 to 45 °C [14 to 113 °F]	-10 to 40 °C [14 to 104 °F]	-10 to 45 °C [14 to 113 °F]	-10 to 40 °C [14 to 104 °F]		
Thermal Protection	none					
Mounting Orientation	can be mounted in any orientation					
Corrosive Gases	NOT compatible with any corrosive gases					
Weight	2.9 oz [83g]	2.6 oz [75g]	20.3 oz [575g]	2.9 oz [83g]	2.6 oz [75g]	20.3 oz [575g]
Agency Approvals	RoHS			cUL _{US} listed (E333109), RoHS		
Optional Accessories *						
Replacement Potentiometer	GSDA-5K					

* For accessories details, refer to the "GSD Series DC Drives Accessories" section.

** Plugging is a method of rapidly changing motor direction by reversing motor armature polarity, while the motor is still running.

GSD3 Series DC Drives

GSD3 Wiring Diagrams

GSD3-24x-xxx Basic Wiring Diagram – (refer to User Manual for more detailed wiring information)

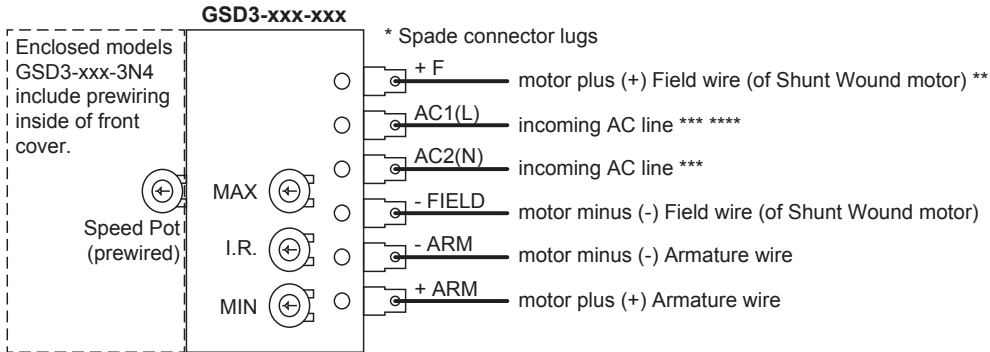

* For wiring connections, use customer-supplied Sta-Kon 0.25 in x 0.25 in spade connectors or similar.

** +F connection is only for Shunt Wound motor; NOT for Permanent Magnet motor.
For motors with dual voltage field, i.e. 50/100V or 100/200V, connect the highest value.

*** Use normal-blow fuses in series with all ungrounded (hot) AC inputs, rated to 125% of motor current.
NOTE: Fuse both AC input lines for 240 VAC input, where both lines are hot. For line-to-neutral circuits, fuse the hot input line and connect it to AC1.

**** GSD3-240-3N4 drives include a replaceable built-in fuse wired in line with AC1.
(Fuse is 250VAC, 6.3A Littlefuse 21606.30 or equivalent.)

GSD3 Dimensions – dimensions = in [mm]

GSD3-24x-2CJ Dimensions

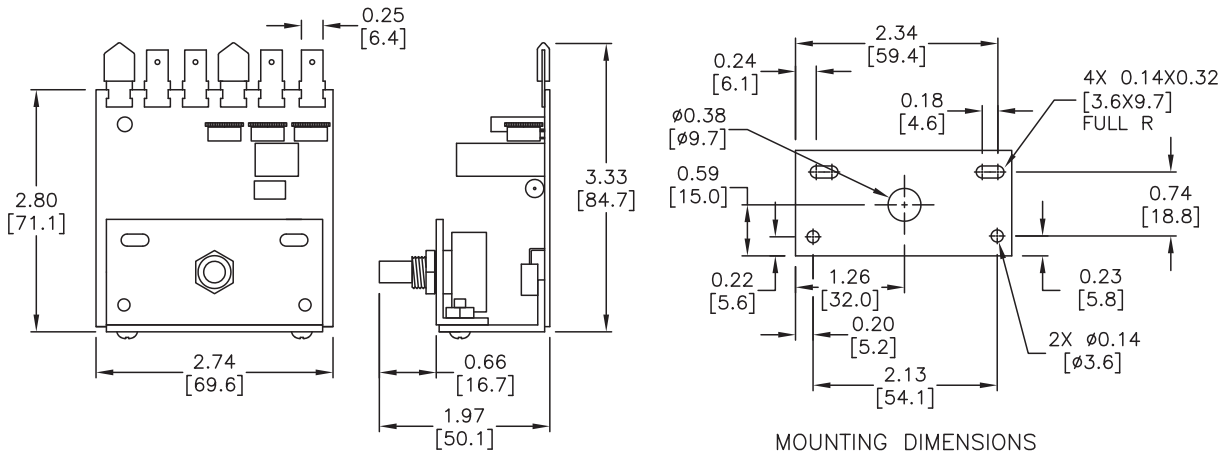

GSD3-24x-2CL Dimensions

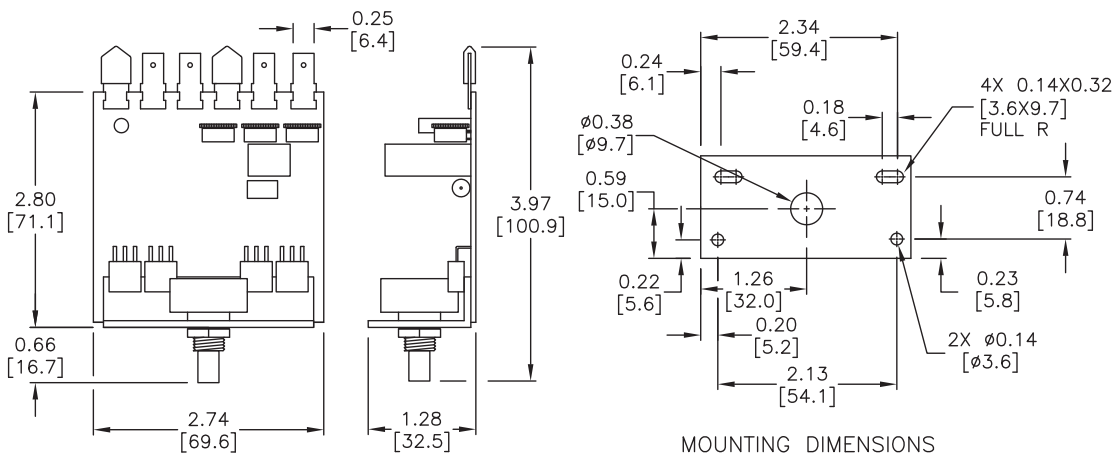

GSD3 Series DC Drives

GSD3 Dimensions — dimensions = in [mm]

GSD3-24x-3N4 Dimensions

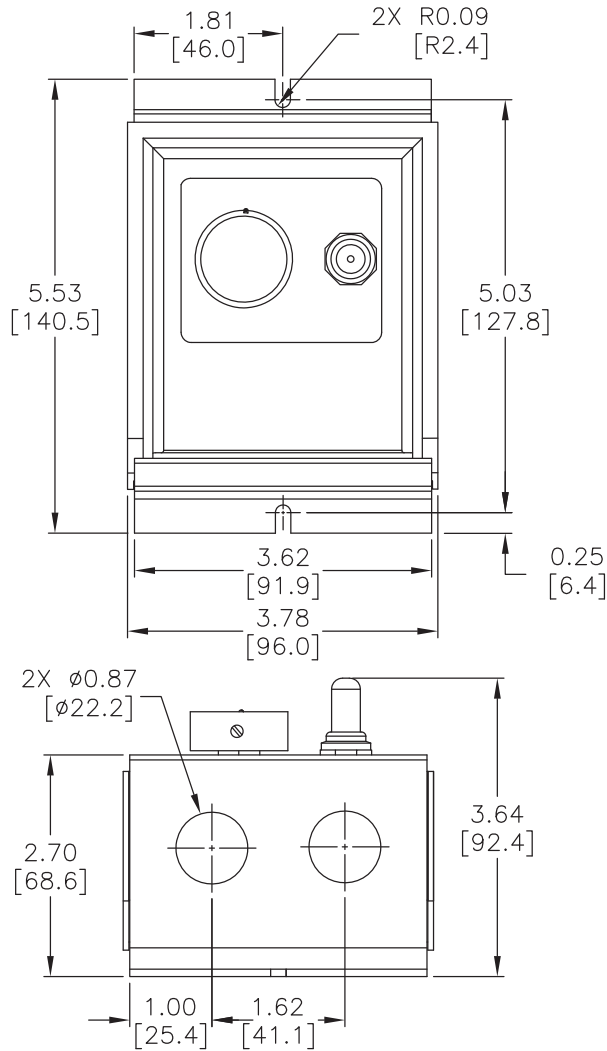

GSD4 Series DC Drives

GSD4 Introduction



GSD4-24x-xC



GSD4-240-10N4X

GSD4 Series DC Drives	
Motor Rating Range @ 24/36 VAC _{IN}	1/50 – 1/6 hp
Motor Rating Range @ 120/240 VAC _{IN}	1/50 – 2 hp

Overview

IronHorse GSD4 series DC drives provide cost efficient, reliable control for permanent magnet, shunt wound, and universal motors. The drives incorporate up-to-date design and engineering in a compact package.

Installation and field adjustments are facilitated using a barrier type terminal strip and large, easily adjustable trim pots to adjust horsepower ranges.

The GSD4-24A-5C model operates on a low input voltage of 24/36 VAC with an output of 1/50 – 1/6 hp.

Standard features include an inhibit circuit for start-stop operation, and 1% speed regulation over a 50:1 speed range. Dual voltage 120/240 VAC or 24/36 VAC models are available.

Long life and quality are assured by 100% full load testing.

Features

- Dual input voltage 120/240 VAC or 24/36 VAC, 50/60Hz
- Adjustable horsepower settings
- Barrier terminal strip
- Full-wave bridge supply
- 1% speed regulation with armature voltage feedback ($\pm 1/2\%$ with tach feedback)
- Adjustable minimum speed
- Adjustable maximum speed
- Adjustable IR compensation
- Adjustable current limit
- Adjustable acceleration and deceleration (enclosed model only)
- Line voltage compensation
- 5k Ω speed potentiometer with leads, dial and knob included
- 50:1 speed range
- Overload capacity: 200% for one minute
- Transient voltage protection
- Voltage following mode or DC tachometer follower by supplying ungrounded analog input signal
- DC tachometer feedback
- Inhibit circuit – permits start and stop without breaking AC lines
- Shunt field supply provided

Accessories

- Replacement speed potentiometer kit
- Digital potentiometer
- Manual reverse switch
- Accel/Decel adjustment card
- Analog current input card
- Analog voltage input card
- Heatsink

Detailed descriptions and specifications for GSD accessories are available in the “GSD Series DC Drives Accessories” section.

Typical Applications

- Auger feeders
- Automated door actuators
- Commercial cooking equipment
- Commercial lift
- Food production
- Industrial pumping systems
- Measurement instruments
- Miniature lathes and mills
- Packaging / material-handling equipment
- Printing and labeling machines
- Small shop machine tools
- Spray / print reciprocating head

GSD4 Series DC Drives

GSD4 Selection and Specifications

GSD4 Series DC Drives – Selection & Specifications				
Model	GSD4-24A-5C	GSD4-240-1C	GSD4-240-5C	GSD4-240-10N4X
Price	\$77.00	\$66.00	\$68.00	\$248.00
Package Configuration	open frame			NEMA 4X
Power Quality Form Factor	1.4			
Input Voltage (@50/60Hz)	24/36 VAC ±10%	120/240 VAC ±10%		
Output Voltage	0–24/36 VDC	0–90/180 VDC		
Shunt Field Voltage	20VDC @ 24VAC in 30VDC @ 36VAC in (1A max)	100VDC @ 120VAC in 200VDC @ 240VAC in (1A max)	100VDC @ 120VAC in 200VDC @ 240VAC in (0.5A max)	
Motor Rating @ Low V (hp) Motor Rating @ High V (hp)	1/50 – 1/6	1/50 – 1/8 1/25 – 1/4	1/8 – 1/2 1/4 – 1	1/8 – 1 1/4 – 2
Output Current (continuous) **	5.5A (DC)	1.2A (DC)	5.5A (DC)	10A (DC)
Current Overload Capacity	200% for 60s			
Current Limit (adjustable)	1–15A (DC)	0.3–2.5A (DC)	1–15A (DC)	
Transient Protection	none	Metal Oxide Varistor (MOV)		
I.R. Compensation	adjustable			
Speed Adjustment	5kΩ potentiometer or 0–10VDC isolated input signal			
		4–20mA	n/a	
	–	0–5VDC thru 0–250VDC		
Speed Range	50:1			
Speed Regulation	±1% of base speed			
Maximum Speed	adjustable from 60% to 110% of base speed			
Minimum Speed	0–30% of adjustable maximum speed			
Acceleration	0.5s (fixed)			
Deceleration				
Dynamic Braking	no			
Plugging Capability **	no			
Electrical Connections	8-position terminal strip; 22–14 AWG			
External Fusing Required	Bussman ABC or Littlefuse 314 series ceramic fuses or equivalent Refer to wiring diagrams for details			
Operating Temperature	-10 to 45 °C [14 to 113 °F]		-10 to 40 °C [14 to 104 °F]	
Thermal Protection	current limiting			
Mounting Orientation	can be mounted in any orientation			
Corrosive Gases	NOT compatible with any corrosive gases			
Weight	8.0 oz [203g]	37 oz [1049g]	10.5 oz [297g]	59.5 oz [1687g]
Agency Approvals	RoHS, CE	cUL _{US} listed (E198015), RoHS, CE		cUL _{US} listed (E198015), RoHS
Optional Accessories *				
Replacement Potentiometer	GSDA-5K			
Digital Potentiometer	GSDA-DP			
Manual Reverse Switch	GSDA-MREV			
Accel/Decel Adjustment Card	GSDA-ACCDEC-4			
Analog Current Input Card	GSDA-AI-A		–	
Analog Voltage Input Card	–	GSDA-AI-V4		–
Heatsink	GSDA-HTSNK-4			–

* For accessories details, refer to the "GSD Series DC Drives Accessories" section.

** Plugging is a method of rapidly changing motor direction by reversing motor armature polarity, while the motor is still running.

GSD4 Series DC Drives

GSD4 Wiring Diagrams

GSD4-24x-xC Basic Wiring Diagram – (refer to User Manual for more detailed wiring information)

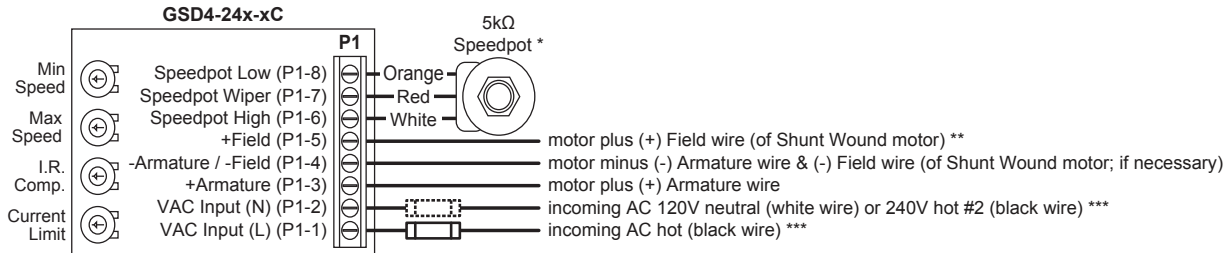

* P1-6 has internal +12V, and connects to Speedpot High (white wire). THIS INPUT MUST NOT BE GROUNDED!

For start-stop applications, the connection between P1-6 and Speedpot High can be opened and closed by a SPST switch.

* P1-7 connects to Speedpot Wiper (red wire). THIS INPUT MUST NOT BE GROUNDED!

For Voltage-Follower applications, THIS INPUT MUST NOT BE GREATER THAN +12V MAXIMUM!

* P1-8 connects to Speedpot Low, and is raised and lowered by the Min Speed trimpot. THIS INPUT MUST NOT BE GROUNDED!

Electronic speed input (voltage follower) may be referenced to this input if the Min Speed trimpot adjustments are to be active.

Otherwise, inputs may be referenced to -Armature, which will bypass the Min Speed trimpot.

** +F connection is only for Shunt Wound motor; NOT for Permanent Magnet motor.

For motors with dual voltage field, i.e. 50/100V or 100/200V, connect the highest value.

*** Fuse hot AC inputs only; refer to Fusing section for size and type. Fuse both AC lines for 240 VAC input. Do NOT fuse AC(N) on 120V systems.

Connect incoming AC ground (green wire) to GSD4 chassis.

GSD4-240-10N4X Basic Wiring Diagram – (refer to User Manual for more detailed wiring information)

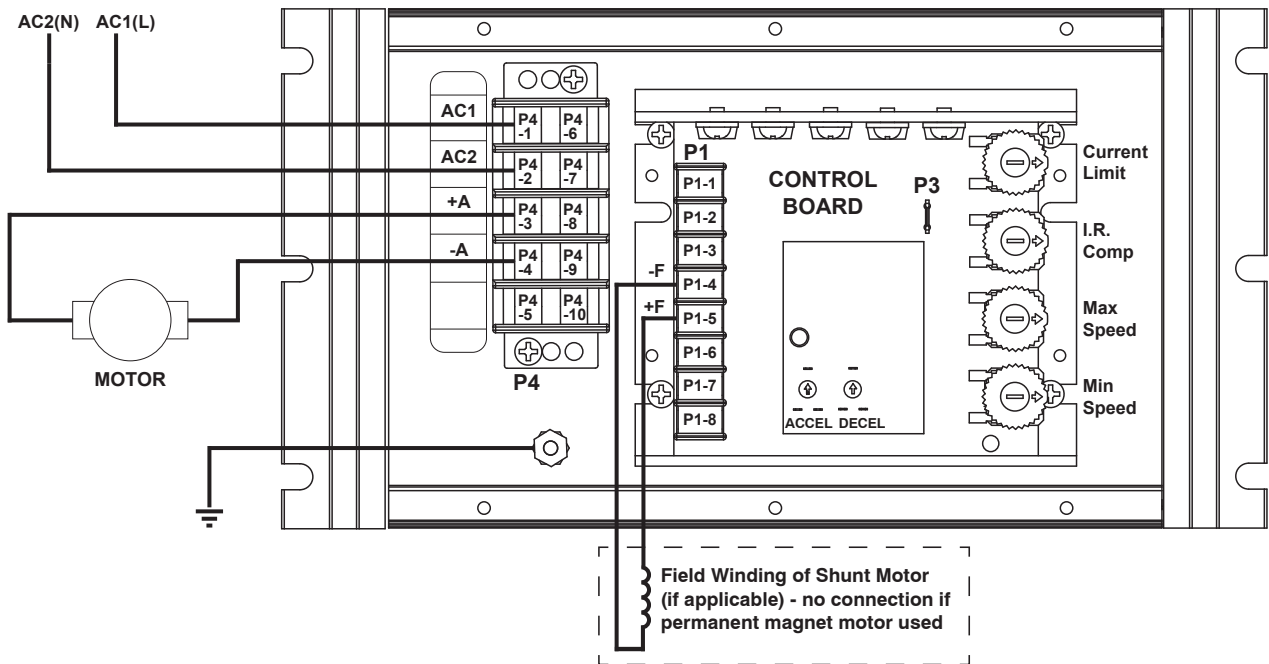

GSD4 Series DC Drives

GSD4 Dimensions – dimensions = in [mm]

GSD4-24x-xC Dimensions

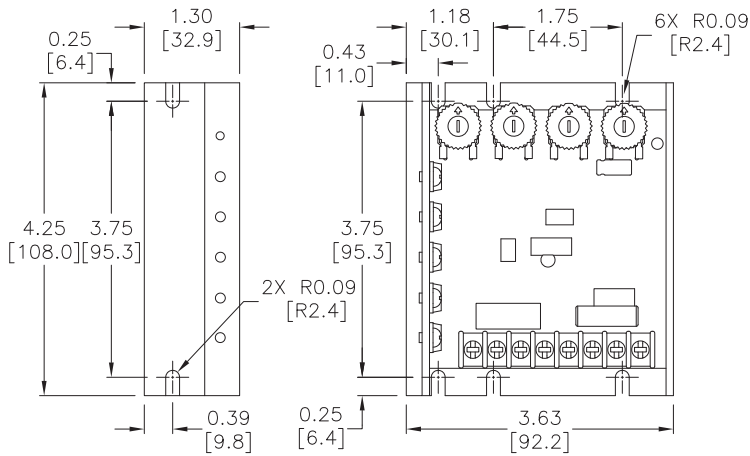

GSD4-240-10N4X Dimensions

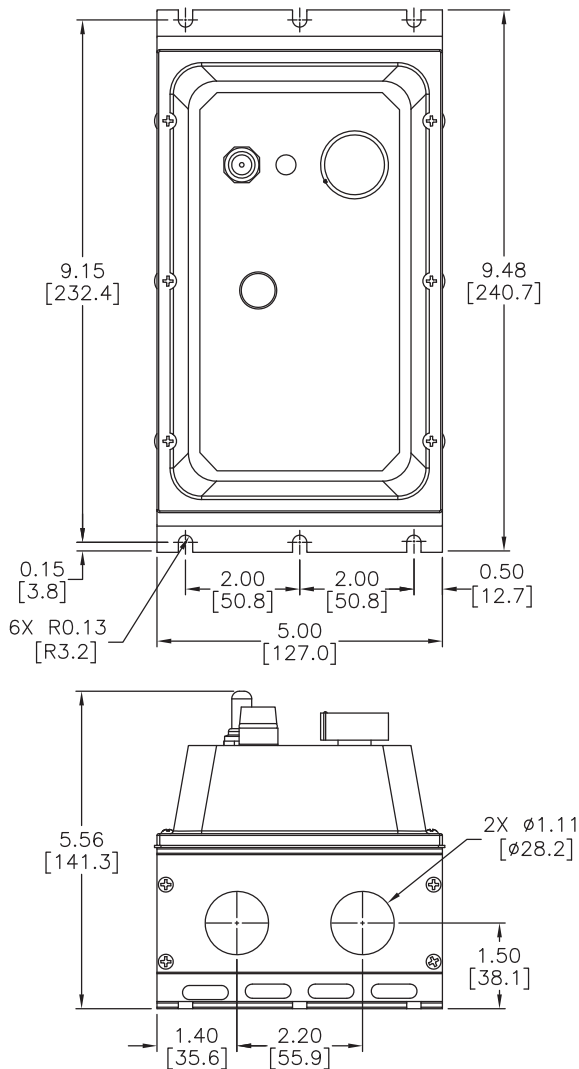

GSD5 Series DC Drives

GSD5 Introduction



GSD5-240-10C



GSD5-240-10N4-x

GSD5 Series DC Drives	
Motor Rating Range @ 120/240 VAC _{IN}	1/8 – 2 hp

Overview

IronHorse GSD5 series DC drives offer superb flexibility, reliability, and value. A general purpose, economical line of drives rated to 2 horsepower, it provides the ultimate in standard features and versatility, offered in open-frame and NEMA 4/12 enclosed models.

A logical, easily-accessible layout simplifies installation and adjustment. Clean design, quality components and careful assembly are trademarks of IronHorse GSD DC drives.

Features

- Dual input voltage – 120/240 VAC, 50/60Hz
- Adjustable horsepower settings
- Barrier terminal strip
- Packaged bridge supply (full wave)
- 1% speed regulation with armature voltage feedback ($\pm 1/2\%$ with tach feedback)
- Adjustable minimum speed
- Adjustable maximum speed
- Adjustable IR compensation
- Adjustable linear acceleration
- Adjustable current limit
- Line voltage compensation
- 5k Ω speed potentiometer with leads, knob, and dial included
- Power on/off switch (enclosed models)
- 50:1 speed range
- Overload capacity: 150% for one minute
- Transient voltage protection
- Voltage following mode or DC tachometer follower by supplying ungrounded analog input signal
- DC tachometer feedback
- Inhibit circuit – permits start and stop without breaking AC lines
- Remote start/stop via pot circuit or inhibit circuit
- Shunt field supply provided
- AC line fuse
- Enclosed models rated NEMA 4/12 with threaded conduit holes

Accessories

- Replacement speed potentiometer kit
- Digital potentiometer
- Manual reverse switch
- Analog current input card
- Analog voltage input card

Detailed descriptions and specifications for GSD accessories are available in the "GSD Series DC Drives Accessories" section.

Typical Applications

- Auger feeders
- Automated door actuators
- Commercial cooking equipment
- Commercial lift
- Food production
- Industrial pumping systems
- Measurement instruments
- Miniature lathes and mills
- Packaging / material-handling equipment
- Printing and labeling machines
- Small shop machine tools
- Spray / print reciprocating head

GSD5 Series DC Drives

GSD5 Selection and Specifications

GSD5 Series DC Drives – Selection & Specifications					
Model	GSD5-240-10C	GSD5-240-10N4	GSD5-240-10N4-A	GSD5-240-10N4-R	GSD5-240-10N4-V
Price	\$135.00	\$176.00	\$247.00	\$265.00	\$267.00
Package Configuration	open frame	NEMA 4/12			
Power Quality Form Factor	1.4				
Special Features	none		current follower	manual reversing	voltage follower
Input Voltage (@50/60Hz)	120/240 VAC ±10%				
Output Voltage	0–90/180 VDC				
Shunt Field Voltage	100VDC @ 120VAC input ; 200VDC @ 240VAC input ; (1A max)				
Motor Rating (hp)	1/8 – 1 hp @ 90VDC ; 1/4 – 2 hp @ 180VDC				
Output Current (continuous)	150mA – 10.8A (DC)				
Current Overload Capacity	150% for 60s				
Current Limit (adjustable)	1–15A (DC)				
Transient Protection	Metal Oxide Varistor (MOV)				
I.R. Compensation	adjustable				
Speed Adjustment	5kΩ 2W potentiometer or 0–10VDC isolated input signal				
Speed Range	50:1				
Speed Regulation	±1% of base speed (0.5% with tachometer feedback)				
Maximum Speed	adjustable from 66% to 110% of base speed				
Minimum Speed	linear ramp 0–30% of adjustable maximum speed				
Acceleration	linear ramp adjustable 0.5–8s				
Deceleration	adjustable 0.06–80s (dependent on acceleration time setting)				
Dynamic Braking	no				
Plugging Capability **	no				
Electrical Connections	barrier-type terminal strip; 26–12 AWG				
External Fusing Required	Bussman ABC or Littlefuse 314 series ceramic fuses or equivalent Refer to wiring diagrams for details				
Operating Temperature	-10 to 45 °C [14 to 113 °F]				
Thermal Protection	current limiting				
Mounting Orientation	can be mounted in any orientation				
Corrosive Gases	NOT compatible with any corrosive gases				
Weight	16.25 oz [413g]	25.50 oz [723g]			
Agency Approvals	cUL _{US} listed (E333109), RoHS				RoHS
Optional Accessories *					
Replacement Potentiometer	GSDA-5K				
Digital Potentiometer	GSDA-DP				
Manual Reverse Switch	GSDA-MREV	–	–	included	–
Analog Current Input Card	GSDA-AI-A	–	included	–	–
Analog Voltage Input Card	GSDA-AI-V5	–	–	–	included
* For accessories details, refer to the "GSD Series DC Drives Accessories" section.					
** Plugging is a method of rapidly changing motor direction by reversing motor armature polarity, while the motor is still running.					

GSD5 Series DC Drives

GSD5 Wiring Diagrams

GSD5-240-10C Basic Wiring Diagram – (refer to User Manual for more detailed wiring information)

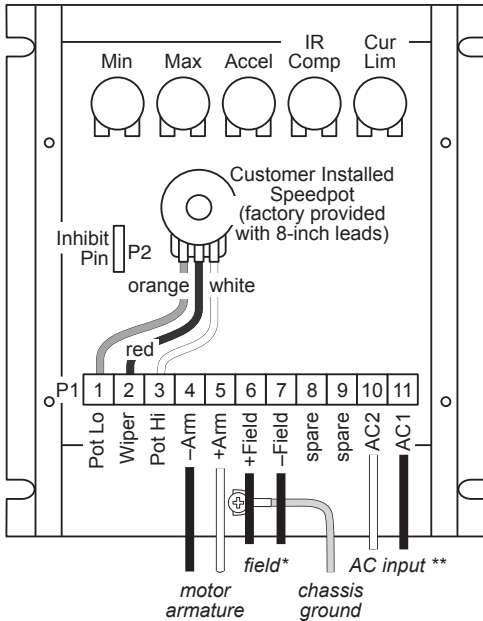

* Field terminals are used for shunt-wound motors only!
Do not connect these terminals when using permanent-magnet motors.

** AC1 terminal is internally fused; AC2 terminal is NOT internally fused.
Add external fuse for AC2 if it is connected to a hot AC line.

GSD5-240-10N4 Basic Wiring Diagram – (refer to User Manual for more detailed wiring information)

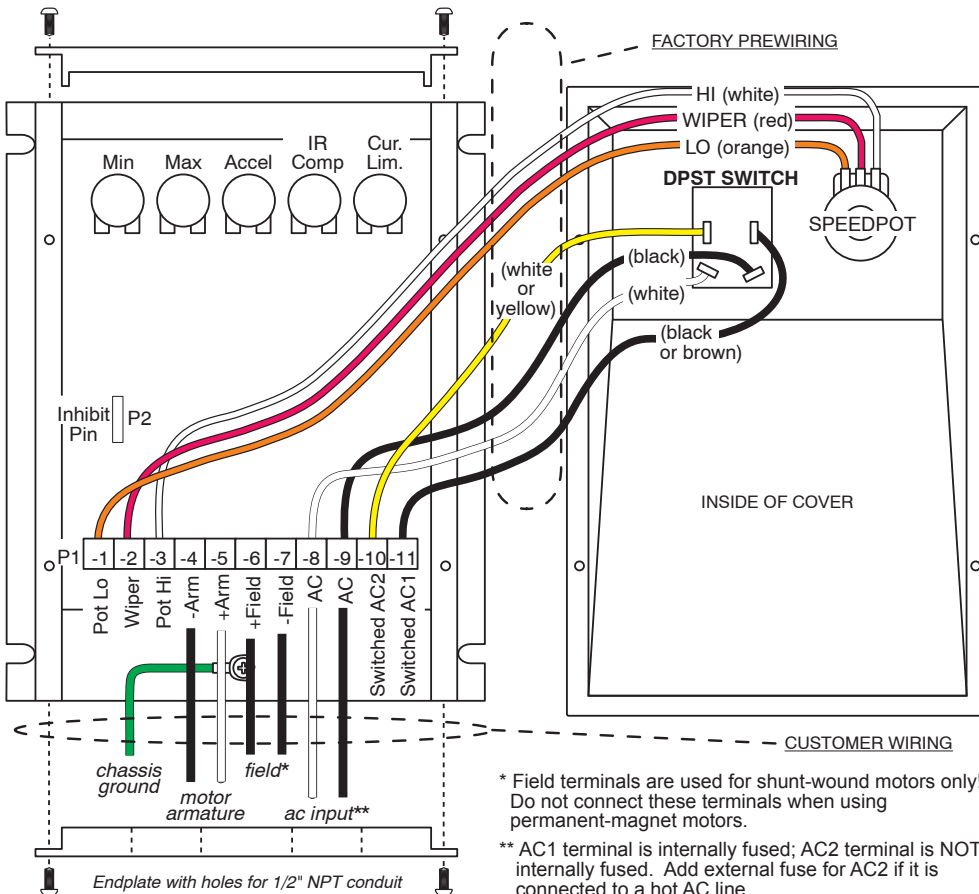

* Field terminals are used for shunt-wound motors only!
Do not connect these terminals when using permanent-magnet motors.

** AC1 terminal is internally fused; AC2 terminal is NOT internally fused.
Add external fuse for AC2 if it is connected to a hot AC line.

GSD5 Series DC Drives

GSD5 Wiring Diagrams

GSD5-240-10N4-A Basic Wiring Diagram – (refer to User Manual for more detailed wiring information)

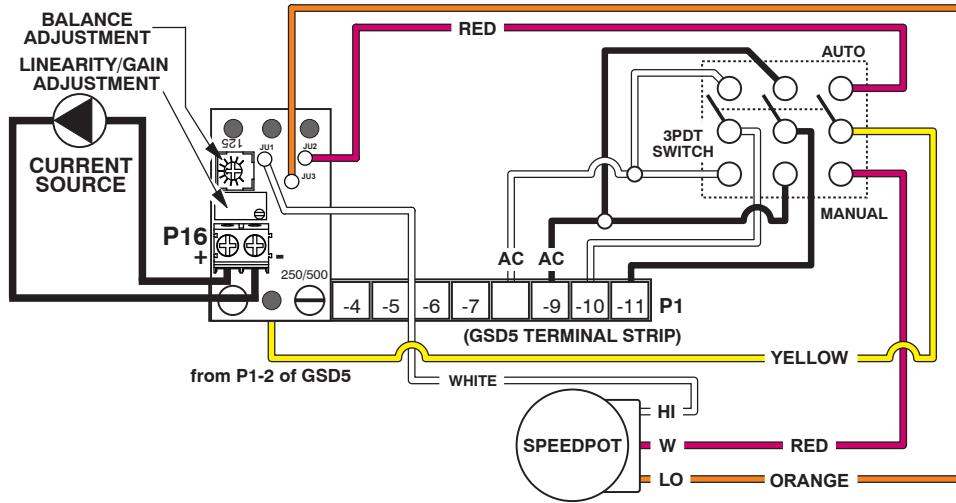

GSD5-240-10N4-V Basic Wiring Diagram – (refer to User Manual for more detailed wiring information)

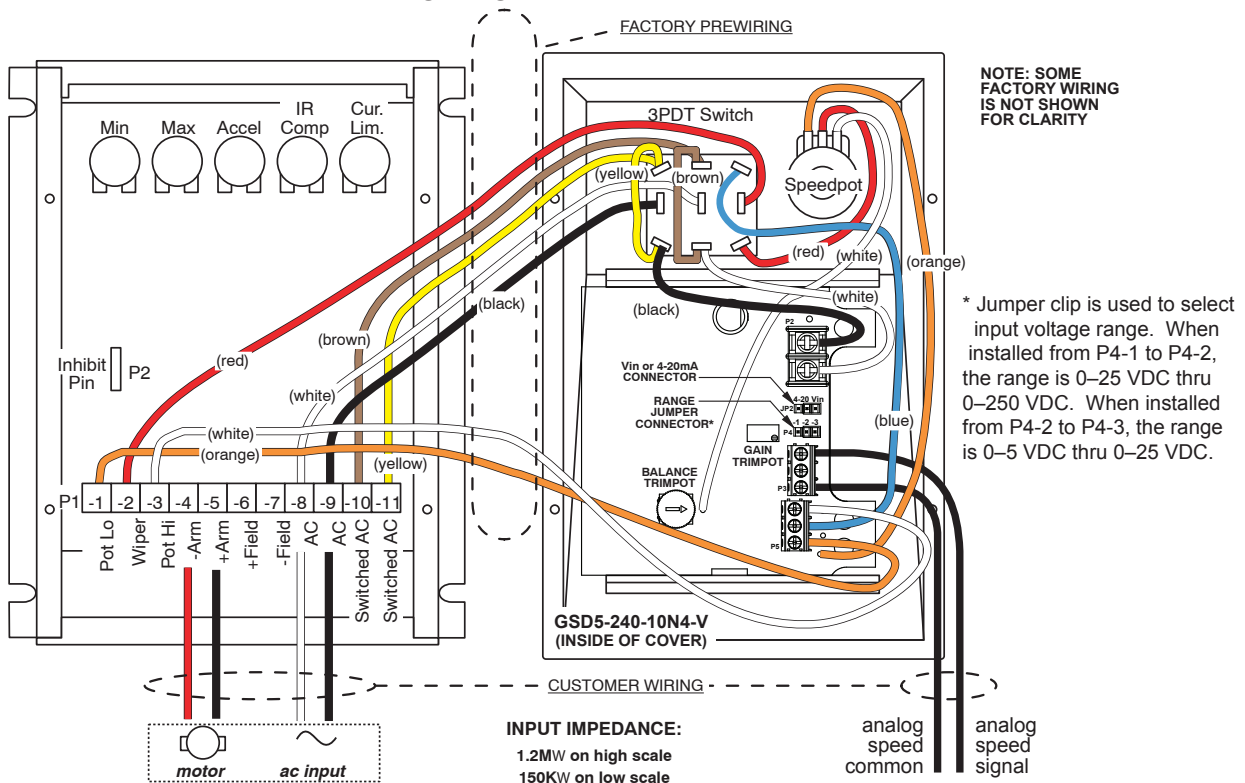

GSD5 Series DC Drives

GSD5 Dimensions – dimensions = in [mm]

GSD5-240-10C Dimensions

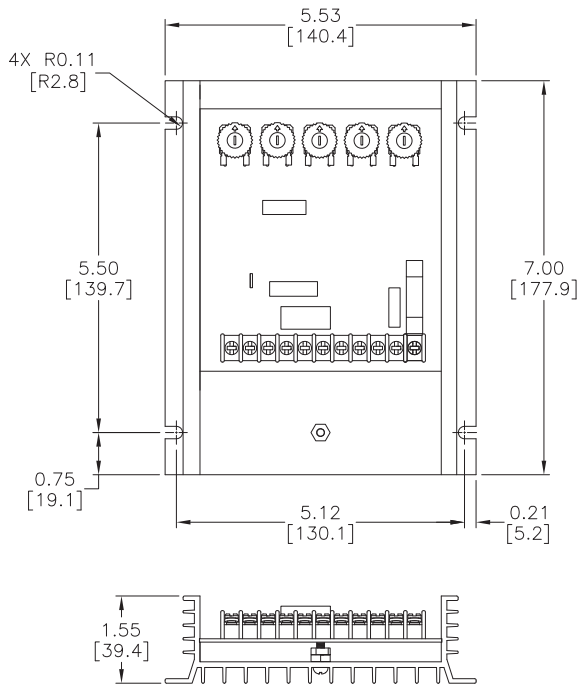

GSD5-240-10N4-x Dimensions

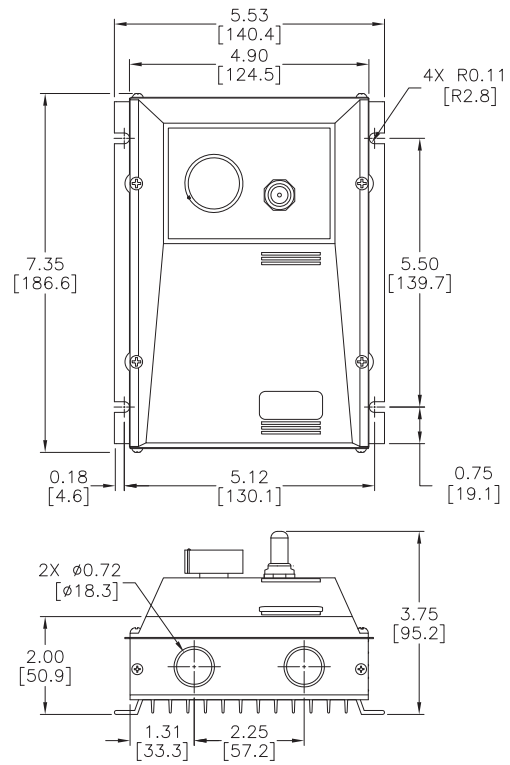

GSD6 Series DC Drives

GSD6 Introduction



GSD6-240-15C

GSD6 Series DC Drives

Motor Rating Range @ 115/230 VAC_{IN}

1/8 – 3 hp

Overview

The reliable, versatile, and economical GSD6 DC drive is the most fully-featured IronHorse analog DC drive.

It provides many standard features typically offered as options by other DC drives.

By combining advanced engineering design, quality component selection, and rigorous quality control, the GSD6 DC drive offers an excellent off-the-shelf SCR control device. Its dependable, time-proven circuitry offers performance characteristics previously available only in more costly drives.

Features

- Dual input voltage 115/230 VAC, 50/60 Hz via slide selector switch
- Adjustable horsepower settings
- Barrier terminal strip
- Packaged bridge supply (full wave)
- 1% speed regulation with armature voltage feedback ($\pm 1/2\%$ with tach feedback)
- Adjustable minimum speed
- Adjustable maximum speed
- Adjustable IR compensation
- Adjustable linear acceleration
- Adjustable linear deceleration
- Adjustable current limit
- Line voltage compensation
- 5k Ω speed potentiometer with leads, dial, and knob included
- 50:1 speed range
- Overload capacity: 200% for one minute
- Transient voltage protection
- Voltage following mode or DC tachometer follower by supplying ungrounded analog input signal
- DC tachometer feedback (jumper selectable)
- Inhibit circuit – permits start and stop without breaking AC lines
- Shunt field supply provided
- AC line fuses
- +12 VDC, 12mA power supply, user accessible

Accessories

- Replacement speed potentiometer kit
- Digital potentiometer
- Analog current input card

Detailed descriptions and specifications for GSD accessories are available in the “GSD Series DC Drives Accessories” section.

Typical Applications

- Auger feeders
- Automated door actuators
- Commercial cooking equipment
- Commercial lift
- Food production
- Industrial pumping systems
- Measurement instruments
- Miniature lathes and mills
- Packaging / material-handling equipment
- Printing and labeling machines
- Small shop machine tools
- Spray / print reciprocating head

GSD6 Series DC Drives

GSD6 Selection and Specifications

GSD6 Series DC Drives – Selection & Specifications	
Model	GSD6-240-15C
Price	\$333.00
Package Configuration	open frame
Power Quality Form Factor	1.4
Input Voltage (@50/60Hz)	115/230 VAC ±10%
Output Voltage	0–90/180 VDC
Shunt Field Voltage	100VDC @ 115VAC input ; 200VDC @ 230VAC input ; (1.5A max)
Motor Rating (hp)	1/8 – 1.5 hp @ 90VDC ; 1/4 – 3 hp @ 180VDC
Output Current (continuous)	15A (DC)
Current Overload Capacity	200% for 60s
Current Limit (adjustable)	2–30A (DC)
Transient Protection	Metal Oxide Varistor (MOV)
I.R. Compensation	adjustable
Speed Adjustment	5k Ω 2W potentiometer
Speed Range	50:1
Speed Regulation	±1% of base speed
Maximum Speed	adjustable from 60% to 120% of base speed
Minimum Speed	linear ramp 0–30% of adjustable maximum speed
Acceleration	linear ramp adjustable 0.3–12s
Deceleration	adjustable 0.6–12s
Dynamic Braking	no
Plugging Capability **	no
Electrical Connections	barrier-type terminal strip; 26–12 AWG
Fusing	(2) 20A fuses included (Bussman ABC-20 or Littelfuse 314020 ceramic fuses or equivalent)
Operating Temperature	-10 to 45 °C [14 to 113 °F]
Thermal Protection	not available
Mounting Orientation	can be mounted in any orientation
Corrosive Gases	NOT compatible with any corrosive gases
Weight	40 oz [1134g]
Agency Approvals	RoHS
Optional Accessories *	
Replacement Potentiometer	GSDA-5K
Digital Potentiometer	GSDA-DP
Analog Current Input Card	GSDA-AI-A
* For accessories details, refer to the "GSD Series DC Drives Accessories" section.	
** Plugging is a method of rapidly changing motor direction by reversing motor armature polarity, while the motor is still running.	

GSD6 Series DC Drives

GSD6 Wiring Diagrams

GSD6-240-15C Basic Wiring Diagram – (refer to User Manual for more detailed wiring information)

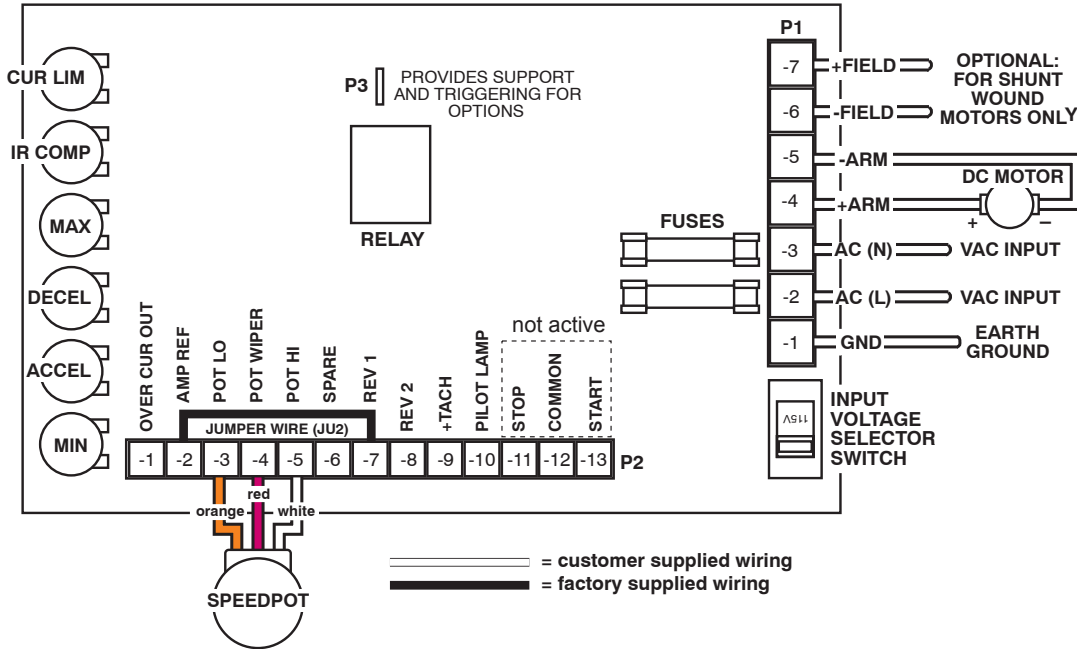

GSD6 Dimensions – dimensions = in [mm]

GSD6-240-15C Dimensions

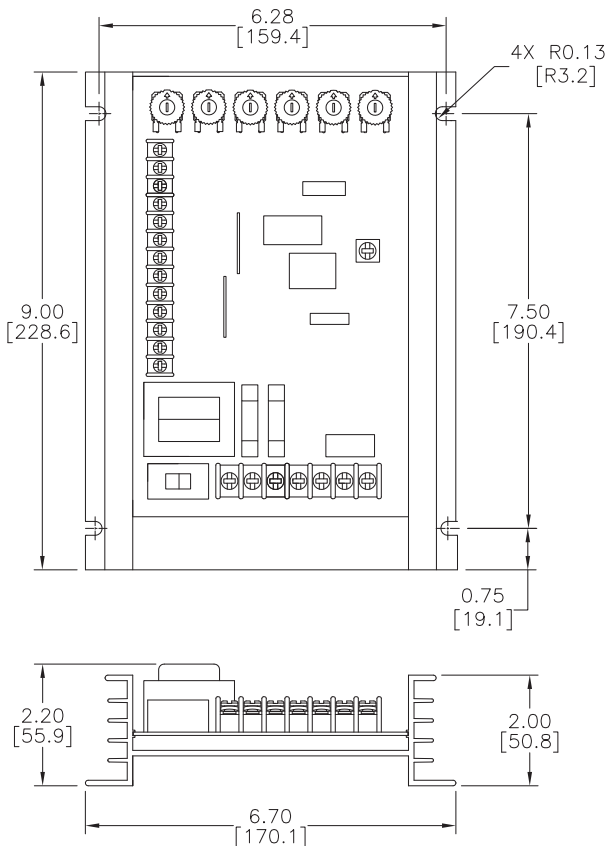

GSD7 Series DC Drives

GSD7 Introduction



GSD7-xxx-xCR3



GSD7-xxx-xCR30

GSD7 Series DC Drives	
Motor Rating Range @ 120 VAC _{IN}	1/50 – 1 hp
Motor Rating Range @ 240 VAC _{IN}	1/25 – 2 hp

Overview

Instant reversing, quick stopping, rapid cycling... The IronHorse GSD7 series DC drives outperform other dynamic braking and reversing drives by utilizing unique zero-speed detect and dynamic braking circuits.

These circuits eliminate the contact arcing and failed braking problems associated with other reversing and dynamic braking drives. The GSD7 zero-speed detect circuit also eliminates motor plug reversing problems.

In the event of a power loss or emergency stop condition, the GSD7 Series DC drives will drop into a dynamic brake condition to safely and quickly bring the motor to a stop.

Features

- Adjustable horsepower settings
- Barrier terminal blocks
- Full-wave bridge supply
- Adjustable minimum speed
- Adjustable maximum speed
- Adjustable IR compensation
- Adjustable current limit
- Fixed acceleration (0.5 sec)
- Line voltage compensation
- 5kΩ pot with leads, dial, and knob included
- 50:1 speed range
- Overload capacity: 200% for one minute
- Transient voltage protection
- Shunt field supply provided
- Onboard dynamic brake resistor
- Automatic dynamic braking on power loss
- 1% speed regulation with armature voltage feedback

Accessories

- Replacement speed potentiometer kit
- Digital potentiometer

Detailed descriptions and specifications for GSD accessories are available in the "GSD Series DC Drives Accessories" section.

Typical Applications

- Auger feeders
- Automated door actuators
- Commercial cooking equipment
- Commercial lift
- Food production
- Industrial pumping systems
- Measurement instruments
- Miniature lathes and mills
- Packaging / material-handling equipment
- PLC-controlled reversing
- Printing and labeling machines
- Small shop machine tools
- Spray / print reciprocating head

GSD7 Series DC Drives

GSD7 Selection and Specifications

Company Information

Drives

Soft Starters

Motors

Power Transmission

Motion: Servos and Steppers

Motor Controls

Sensors: Proximity

Sensors: Photoelectric

Sensors: Encoders

Sensors: Limit Switches

Sensors: Current

Sensors: Pressure

Sensors: Temperature

Sensors: Level

Sensors: Flow

Pushbuttons and Lights

Stacklights

Signal Devices

Process

Relays and Timers

Pneumatics: Air Prep

Pneumatics: Directional Control Valves

Pneumatics: Cylinders

Pneumatics: Tubing

Pneumatics: Air Fittings

Appendix Book 2

Terms and Conditions

GSD7 Series DC Drives – Selection & Specifications							
Model	GSD7-120-1CR3	GSD7-120-1CR30	GSD7-120-5CR3	GSD7-120-10CR30	GSD7-240-1CR3	GSD7-240-5CR3	GSD7-240-10CR30
Price	\$162.00	\$192.00	\$162.00	\$192.00	\$166.00	\$168.00	\$198.00
Package Configuration	open frame						
Power Quality Form Factor	1.4						
Input Voltage (@50/60Hz)	120 VAC ±10%				240 VAC ±10%		
Output Voltage	0–90 VDC				0–180 VDC		
Shunt Field Voltage	100 VDC (1A max)				200 VDC (1A max)		
Motor Rating (hp)	1/15 – 1/8		1/8 – 1/2	1/8 – 1	1/25 – 1/4	1/4 – 1	1/4 – 2
Output Current (continuous)	500mA–1.2A (DC)		500mA–5.5A (DC)	500mA–10A (DC)	500mA–1.2A (DC)	500mA–5.5A (DC)	500mA–10A (DC)
Current Overload Capacity	200% for 60s						
Current Limit (adjustable)	0.3–3A (DC)		1–18A (DC)		0.3–3A (DC)	1–18A (DC)	
Cycling Rate (cycles/min)	3	30	3	30	3	3	30
Transient Protection	Metal Oxide Varistor (MOV)						
I.R. Compensation	adjustable						
Speed Adjustment	5kΩ 0.5W potentiometer or 0–10VDC isolated input signal						
Speed Range	50:1						
Speed Regulation	±1% of base speed						
Maximum Speed	adjustable from 60% to 110% of base speed						
Minimum Speed	linear ramp 0–30% of adjustable maximum speed						
Acceleration	0.5s fixed						
Deceleration	0.5s fixed						
Dynamic Braking	yes						
Plugging Capability **	yes						
Electrical Connections	barrier-type terminal blocks; 22–14 AWG						
External Fusing Required	Bussman ABC or Littlefuse 314 series ceramic fuses or equivalent Refer to "Installation and Wiring" section of user manual for details						
Operating Temperature	-10 to 45 °C [14 to 113 °F]						
Thermal Protection	current limiting						
Mounting Orientation	can be mounted in any orientation						
Corrosive Gases	NOT compatible with any corrosive gases						
Weight	1.1 lb [490g]	3.3 lb [1497g]	1.1 lb [490g]	3.3 lb [1497g]	1.1 lb [490g]	1.1 lb [490g]	3.3 lb [1497g]
Agency Approvals	cUL _{US} (E333109), RoHS						
Optional Accessories *							
Replacement Potentiometer	GSDA-5K						
Digital Potentiometer	GSDA-DP						
* For accessories details, refer to the "GSD Series DC Drives Accessories" section.							
** Plugging is a method of rapidly changing motor direction by reversing motor armature polarity, while the motor is still running.							

GSD7 Series DC Drives

GSD7 Wiring Diagrams

GSD7-xxx-xxxxx Basic Wiring Diagram – (refer to User Manual for more detailed wiring information)

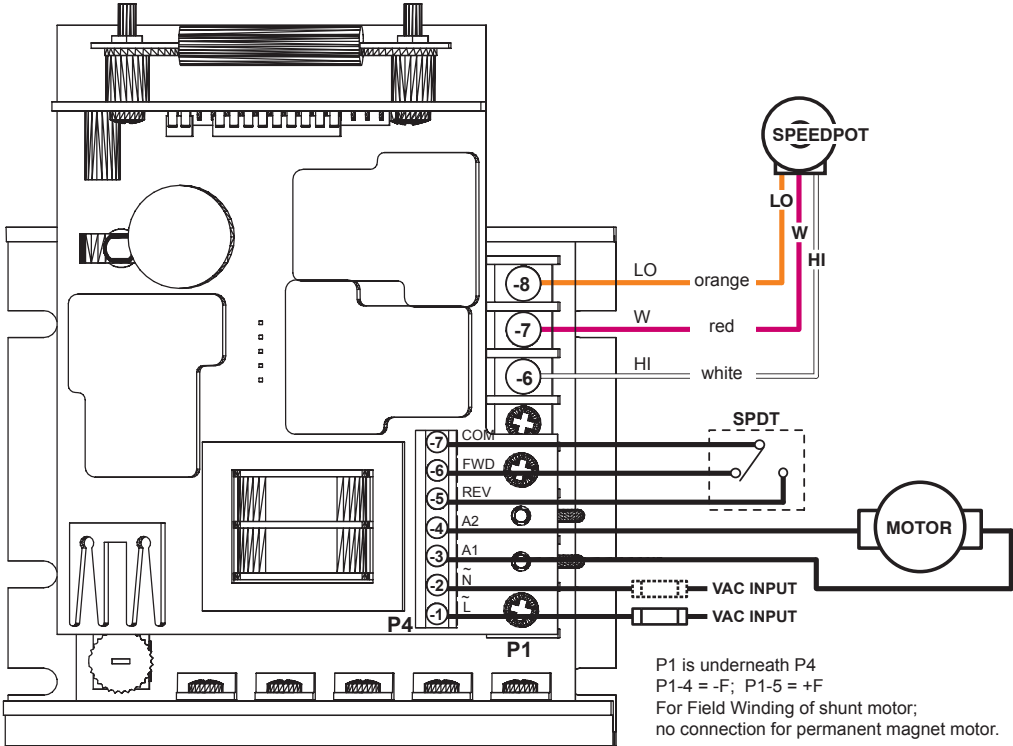

GSD7 Series DC Drives

GSD7 Dimensions – dimensions = in [mm]

GSD7-xxx-xCR3 Dimensions

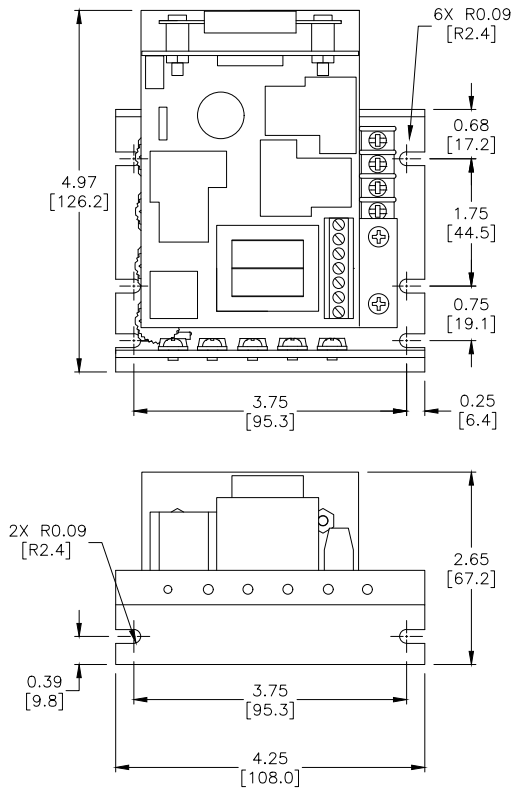

GSD7-xxx-xCR30 Dimensions

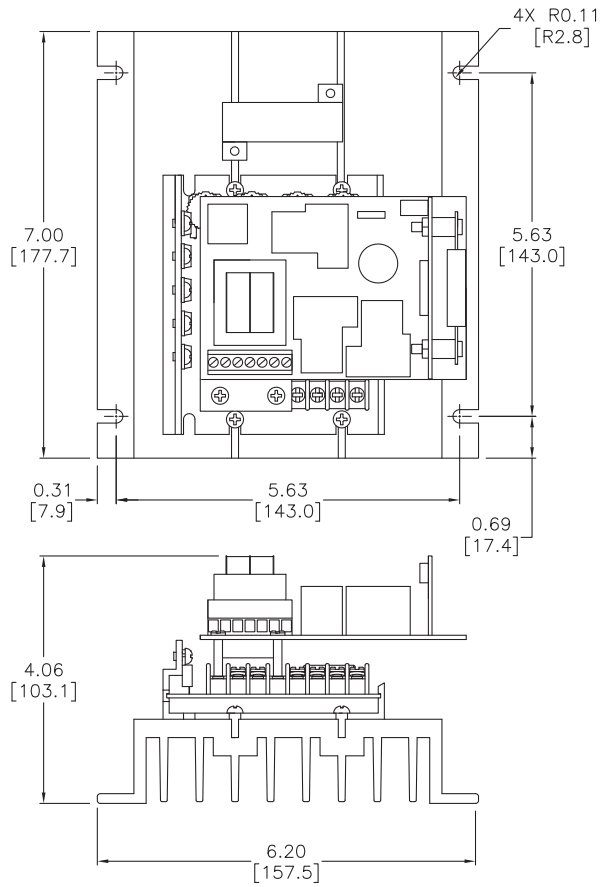

GSD Series DC Drives Accessories

GSDA Accessories for GSD Series DC Drives – Selection & Specifications

GSDA Accessories for GSD Series DC Drives			
Model	Price	Description	For Use With
GSDA-5K	\$14.00	Speed Potentiometer Kit. 5k Ω accessory/replacement. Includes adjustment knob and 0-100% speed dial.	GSD - all
GSDA-ACCDEC-4	\$12.00	Independent Accel/Decel Adjustment Card. Field installable.	GSD4 - all
GSDA-AI-A	\$36.00	Isolated Analog Current Signal Input Card. Range: 4–20mA. Field installable for open-frame drives as shown.	GSD4-24x-xC (open-frame) GSD5-240-10C (open-frame) GSD6 (open-frame)
GSDA-AI-V4	\$81.00	Isolated Analog Voltage Signal Input Card. Range: 0–10V or 0–250V. Field installable for open-frame drives as shown.	GSD4-240-xC (240V open-frame)
GSDA-AI-V5	\$81.00	Isolated Analog Voltage Signal Input Card. Range: 0–10V or 0–250V. Field installable for open-frame drives as shown.	GSD5-240-10C (open-frame)
GSDA-DP	\$221.00	Digital Potentiometer. 120–240 VAC input. Programmable. Outputs any unipolar or bipolar voltage range (based on input voltage) up to 24VDC ($\pm 12V$, $\pm 10V$, 0–5V, 0–24V, etc.). NEMA 4X enclosure fits 1/8 DIN cutout. Replaces analog potentiometers where vibration, repeatability, or precision is a concern.	GSD1 - all GSD4 - all GSD5 - all GSD6 - all GSD7 - all
GSDA-MREV	\$78.00	Manual Reverse Switch. 4PDT rated at 10A. Allows reversing by switching DC motor armature leads. Center-blocking prevents motor leads from reversing when motor is still turning in the previous direction.	GSD4 - all GSD5-240-10C (open-frame)
GSDA-HTSNK-4	\$25.00	Heatsink. Increases the drive's output current rating.	GSD4-24x-xC (open-frame)

NOTE: All GSDA Accessories are RoHS compliant.

GSDA-5K

For use with all GSD series DC drives

The GSDA-5K is a replacement potentiometer kit that can be used with IronHorse GSD series DC drives to control the speed of a DC motor.

(All GSD series DC drives include a speed potentiometer.)

The kit includes:

- (1) 5k Ω potentiometer
- (3) pigtail wiring leads (8-1/2 in; 20 AWG)
- (1) adjustment knob
- (1) 0–100% dial
- (1) mounting nut and lock washer

Wiring Connections

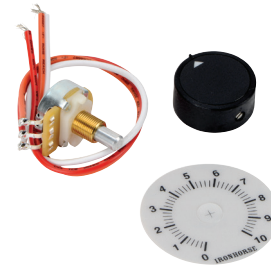
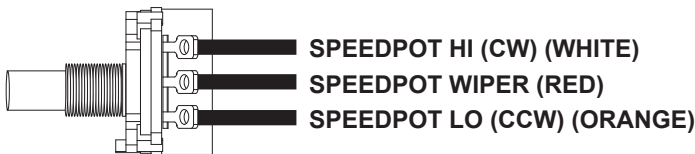

Dimensions (in [mm])

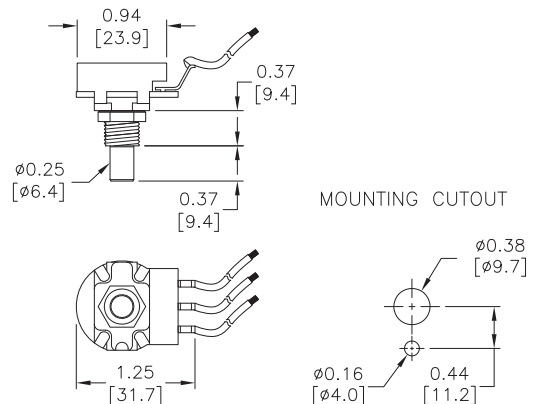

GSD Series DC Drives Accessories

GSDA-ACCDEC-4

For use with all GSD4 DC drives

The GSDA-ACCDEC-4 option card overrides the fixed accel ramp built into the GSD4 drive, providing independently adjustable linear acceleration and deceleration from 0.5 to 8.0 seconds. Adjustments are made via two separate trim pots.

This option card plugs into the expansion connector on the GSD4 main circuit board.

GSDA-ACCDEC-4 installation and wiring information is included in the GSD4 DC Drives User Manual.



GSDA-AI-A

For use with DC drives: GSD4-24x-xC, GSD5-240-10C, GSD6-all (open-frame)

This option card is a 4–20 mA isolated analog current signal card that can replace the speed pot as a speed input signal to certain GSD series drives. The 4–20 mA signal input can be either grounded or ungrounded. The board sets on spacers screwed to the potentiometer HI, Wiper, and LO terminals on the main GSD drive board using screws (included).

GSDA-AI-A installation and wiring information is included in the GSDA-AI-A DC Drives Accessory Data Sheet.

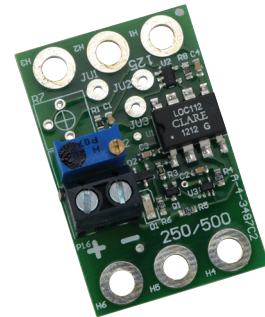

GSDA-AI-V4

For use with GSD4-240-xC (120–240V open-frame) DC drives

This option card allows for the use of either a grounded or non-grounded remote DC signal such as 0–5 VDC through 0–250 VDC, 4–20mA current, or a remote speed pot. The DC input signal type can be selected for voltage (Vin) or current (4–20mA), and there is a GAIN trim pot to set full linear output in reference to the input signal range. The output of this remote signal isolation board is a linear signal that is proportional to the remote input signal being supplied.

GSDA-AI-V4 installation and wiring information is included in the GSD4 DC Drives User Manual.

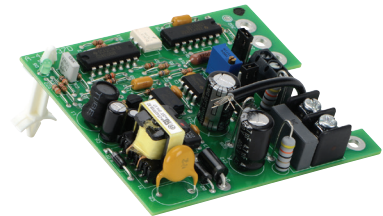

GSDA-AI-V5

For use with GSD5-240-10C (open-frame) DC drives

This option card allows for the use of either a grounded or non-grounded remote DC signal such as 0–5 VDC through 0–250 VDC, 4–20mA, or a remote speed potentiometer. The DC input signal type can be selected for voltage (Vin) or current (4–20mA), and there is a Hi/Lo range selection to select the voltage ranges. The GAIN trim pot is used to set full linear output in reference to the input signal range. The output of this remote signal isolation board is a linear signal that is proportional to the remote input signal being supplied.

GSDA-AI-V5 installation and wiring information is included in the GSD5 DC Drives User Manual.



Company
Information

Drives

Soft Starters

Motors

Power
Transmission

Motion: Servos
and Steppers

Motor Controls

Sensors:
Proximity

Sensors:
Photoelectric

Sensors:
Encoders

Sensors:
Limit Switches

Sensors:
Current

Sensors:
Pressure

Sensors:
Temperature

Sensors:
Level

Sensors:
Flow

Pushbuttons
and Lights

Stacklights

Signal
Devices

Process

Relays and
Timers

Pneumatics:
Air Prep

Pneumatics:
Directional Control
Valves

Pneumatics:
Cylinders

Pneumatics:
Tubing

Pneumatics:
Air Fittings

Appendix
Book 2

Terms and
Conditions

GSD Series DC Drives Accessories

GSDA-MREV

For use with DC drives: GSD3 - all, GSD4 - all, GSD5-240-10C (open-frame)

The GSDA-MREV Manual Reversing Switch is a 4PDT 10A-rated center-blocked manual switch that can be used with IronHorse GSD series DC drives to manually reverse the direction of a DC motor. When switched between the Forward and Reverse positions, the blocked center position causes a delay which protects the DC drive from any voltage that may be on the motor armature terminals. The center position is OFF/NEUTRAL, and is not connected to a wiring terminal.

Use the GSDA-MREV switch to manually reverse a DC motor without damaging the drive.

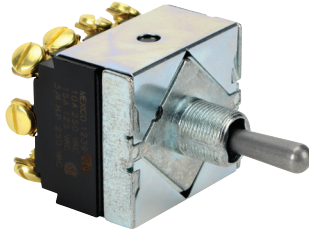

Dimensions (in [mm])

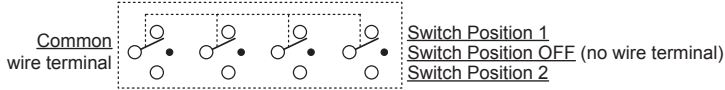
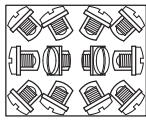
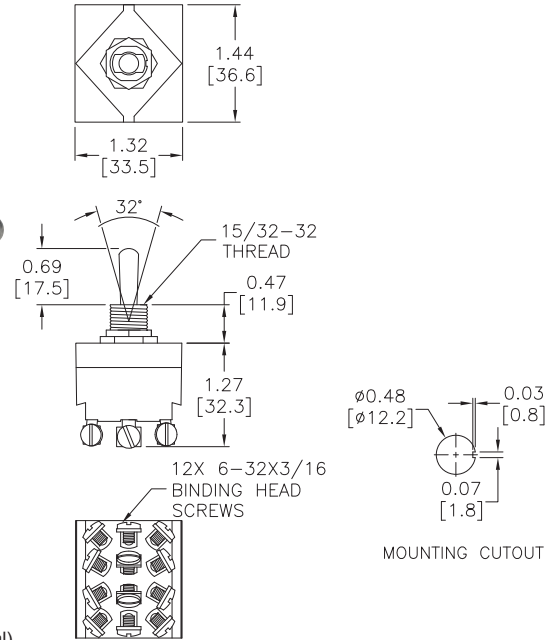

GSDA-HTSNK-4

For use with GSD4-xxx-xC (open-frame) DC drives

Optional heatsink for open-frame GSD4-xxx-1C and GSD4-xxx-5C DC drives only.

Increases the output current capability of GSD4-240-5C drives to 10A (non-UL applications only).



Dimensions (in [mm])

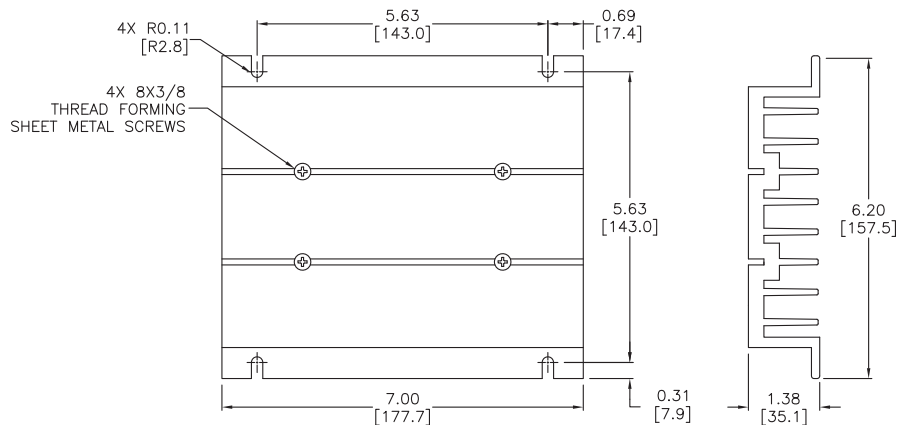

GSD Series DC Drives Accessories

GSDA-DP

For use with DC drives: *GSD1 - all, GSD3-24A-xxx (12–24V), GSD4 - all, GSD5 - all, GSD6 - all, GSD7 - all*

The GSDA-DP digital potentiometer is a compact, microprocessor-based unit capable of being either field or factory configured for a number of industrial user interface / control signal needs. The GSDA-DP allows the user to adjust the displayed value via the front-panel push buttons. As the displayed value is raised or lowered, the output signal from the GSDA-DP follows proportionally according to the unit's configuration. These units support both unipolar and bipolar output and are capable of automatically inverting, scaling, and offsetting the output as needed. The GSDA-DP series is ideal for volume OEM applications requiring specialized inputs and outputs.

The GSDA-DP durable 1/8 DIN aluminum housings can be easily mounted in a panel or control cabinet.



Standard Features

- Microprocessor-based design combines the ultimate in responsiveness and accuracy in one package
- Non-volatile memory stores adjustable parameters even when power has been removed
- Adjustable parameters include display range, output range, output polarity, alarm options, etc.
- Internal program-enable jumper selectively prevents tampering with unit's configuration
- Universal power supply accepts line voltages inputs from 85–265 VAC @ 50–60Hz without switches or jumpers. The unit automatically adjusts as needed.
- Transient voltage protection prolongs unit's life in harsh industrial environments
- Self-contained power supply for external sensor, limited to 5V @ 50mA
- 1/8 DIN durable aluminum housing for panel mounting
- Large 4-digit, 1/2" LED display
- G.E. Lexan membrane and gasket (which are included) meet NEMA 4X standards when used with NEMA 4X enclosures
- Wide operating ambient temperature range of -10 °C to 45 °C (14 °F to 113 °F)
- Multiple operating modes including:
 - Rate Mode* – Displays in rate and non-rate units such as rpm, gallons per second, and percent
 - Time Mode* – Displays in time units such as HH:MM, MM:SS, SS:TT, or other units
 - Rate and Time Modes operate inversely from each other

GSDA-DP – Specifications

Electrical	Line Input Voltage	85–265 VAC
	Line Input Frequency	48–62 Hz
	Display Range	0.001 – 9999
	Units of Operation	User Programmable, any Unit
	Onboard Power Supply (externally accessible)	5V @ 50mA
	Pot Lo/Hi Supply VDC Range (external supply)	0–2 VDC through 0–24 VDC
	Pot Wiper VDC Range	Pot Lo +50mV through Pot Hi -50mV
	Pot Circuit Current Draw	2mA @ 12V
	Pot Circuit Isolation	>500 MΩ
	Isolated Alarm Relay Output Ratings	250VAC @ 5A; Form C
	Resolution of D-A Converter	10 bits
Analog Output	Any unipolar or bipolar voltage range (based on input voltage) up to 24VDC	
Mechanical	Display Type	LED, Red, 4-Digit, 1/2 in Height
	Housing Type (with supplied gasket in NEMA 4X panel)	1/8 DIN NEMA 4X
	Connector Style	12-position 5mm European Style
	Terminal Block Torque Setting	4.4 lb-in Max [0.5 N-m]
	Faceplate Material	Polycarbonate with GE Lexan Overlay
	Housing Material	Aluminum
	Weight	14.4 oz [408.22g]
Environmental	Operating Temperature Range	-10 °C to 45 °C [14 °F to 113 °F]
	Operating Humidity Range	95% non-condensing
Regulatory	Agency Approvals	RoHS

GSD Series DC Drives Accessories

GSDA-DP

GSDA-DP Mounting

GSDA-DP Operation Modes

Rate and Time mode cycle times operate inversely from each other.

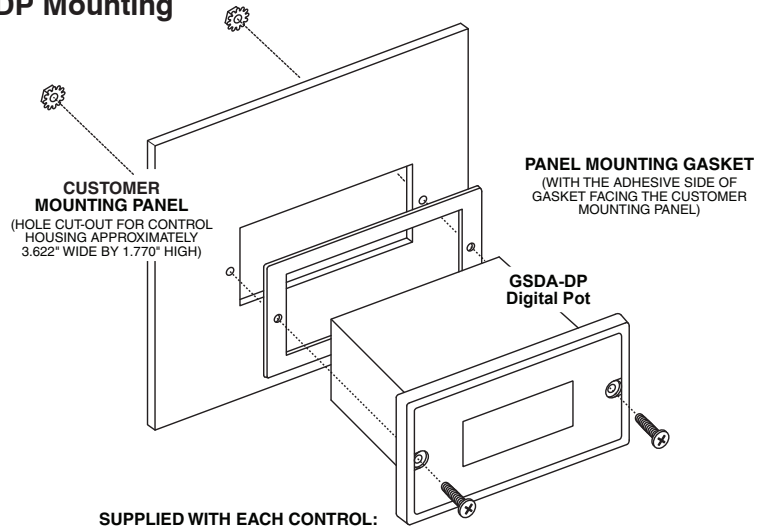
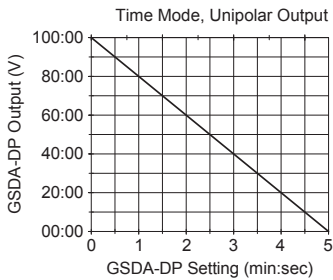
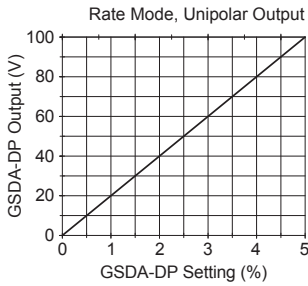

- SUPPLIED WITH EACH CONTROL:**
- 1) GASKET
 - 2) (2) 6-32 X 3/4 PANHEAD BLACK OXIDE STAINLESS SCREWS
 - 3) (2) #6 NUT WITH LOCKWASHER

GSDA-DP Wiring

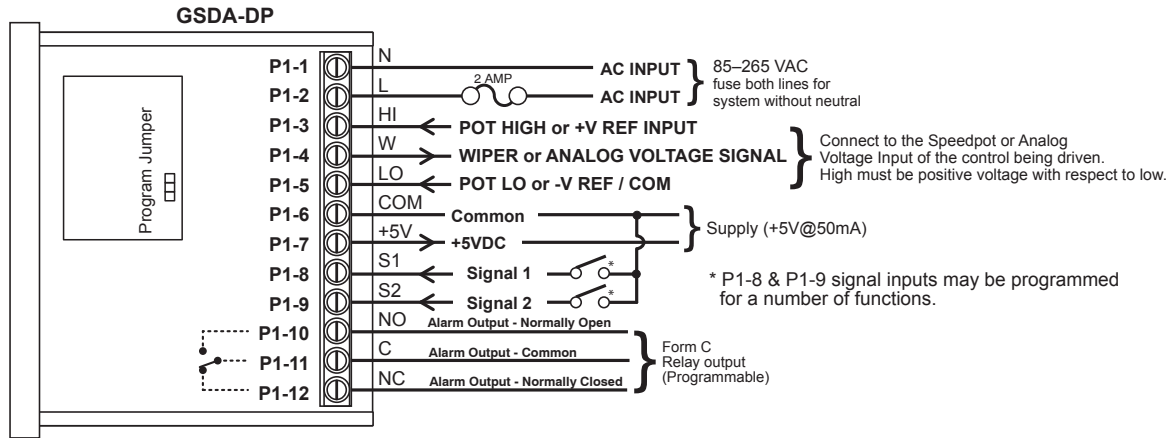

GSDA-DP Dimensions (in [mm])

