

AUTOMATIONDIRECT.com

Direct LOGIC / Koyo

DL05 and DL06 Programmable Logic Controllers (PLC)

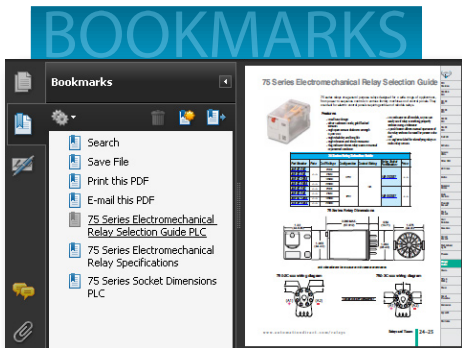

In this interactive PDF you can:

- Use bookmarks to navigate by product category
- Use bookmarks to save, search, print or e-mail the catalog section
- Click on part #s to link directly to our online store for current pricing, specs, stocking information and more

Up-to-date price list:

www.automationdirect.com/pricelist

FREE Technical Support:

www.automationdirect.com/support

FREE Videos:

www.automationdirect.com/videos

FREE Documentation:

www.automationdirect.com/documentation

FREE CAD drawings:

www.automationdirect.com/cad

Company Information

Control Systems Overview

CLICK PLC

Do-More PLCs Overview

Do-More H2 PLC

Do-More T1H PLC

Direct LOGIC PLCs Overview

Direct LOGIC DL05/06

Direct LOGIC DL105

Direct LOGIC DL205

Direct LOGIC DL305

Direct LOGIC DL405

Productivity Controller Overview

Productivity 3000

Universal Field I/O

Software

C-More HMI

C-More Micro HMI

ViewMarq Industrial Marquees

Other HMI

Communications

Appendix Book 1

Terms and Conditions



Micro PLCs With Incredible Features At Affordable Prices

DL06
starting at
\$251.00

The DL05 and DL06 are a family of micro PLCs designed to be versatile and fit most applications with ease.



Starting with the DL05 at 8 inputs/6 outputs, all the way up to the fully expanded 100 I/O DL06, these PLCs are a standard that can grow with the changing needs of your machine or process control application.

Both the DL05 and DL06 feature:

Discrete on/off control

- AC, DC sink/source and relay I/O available
- 17 models total, in both AC and DC- powered units
- Panel mount and DIN-rail mounting for all unit
- Removable terminal blocks (standard)
- Built-in high-speed I/O for simple single axis motion applications (not available on all models)

Analog control

- 13 choices of analog I/O option modules compatible with both DL05 and DL06, including high-resolution models
- PID with auto-tune (standard on all models)
- Analog I/O is jumper range selectable
- Removable terminal blocks for easy wiring and setup
- Temperature inputs (thermocouple and RTD)

Communication and specialty modules

- Two built-in serial communication ports (standard on all models)
- Modbus RTU master/slave (standard on Port 2 of all models)
- Two-port serial communication module with *DirectNET* and Modbus RTU
- Triple-port BASIC CoProcessor module
- Ethernet, DeviceNet™, PROFIBUS™ option modules —compatible with all models
- 1-channel in/1-channel out high speed counter/pulse output module

The DL06 includes 36 integrated discrete I/O points (20 inputs/16 outputs). Four option module slots support up to 24 analog channels or up to 64 additional discrete points. It also includes high-speed counting, pulse output and RS-232/422/485 communication on Modbus RTU master/slave, or use the powerful ASCII In/Out instructions, eight PID loops, and more.

The DL05 includes 14 integrated discrete I/O points (8 inputs/6 outputs). One option module slot can support an analog module, discrete module, memory cartridge or DeviceNet Slave module. It also includes integrated features like high-speed counting, pulse output, two communication ports for Modbus master/slave, four PID loops, and more.

Option modules expand your I/O count and your choices

The DL05 can expand up to 30 I/O points and the DL06 up to 100 I/O points.

DL05
starting at
\$125.00



Discrete modules

I/O
modules work
in both
DL06 & DL05

- Discrete I/O modules: DC in, AC in, DC out, DC in/out, relay out
- Analog I/O modules: four channel current in, four channel voltage in, eight channel voltage or current in (high-res), two channel in/two channel voltage out, four channel in/two channel current out, four channel in/two channel voltage out, four channel voltage or current out (high-res), eight channel voltage or current out (high-res) thermocouple, and RTD inputs
- All modules have removable terminal blocks
- 16-point modules are ZIPLink compatible

Analog modules

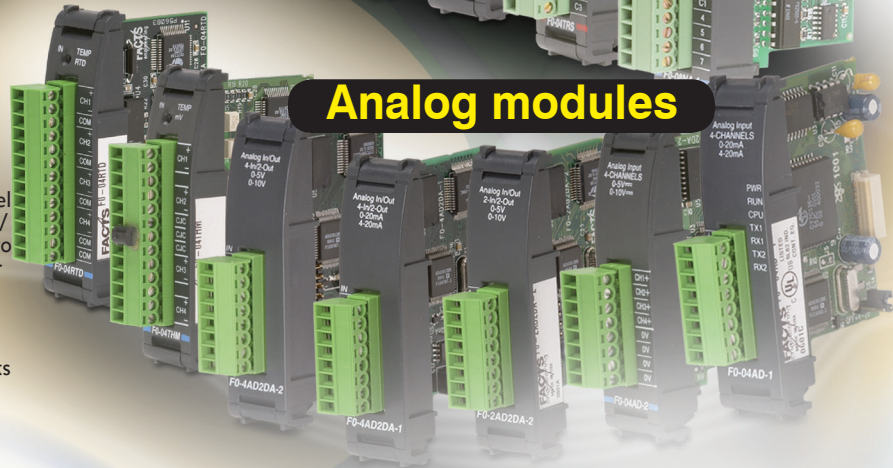

Specialty modules



See ZIPLinks, our "five-second wiring solution" in the Wiring Solutions section

Company Information

Control Systems Overview

CLICK PLC

Do-More PLCs Overview

Do-More H2 PLC

Do-More T1H PLC

Direct.LOIC PLCs Overview

Direct.LOIC DL05/06

Direct.LOIC DL105

Direct.LOIC DL205

Direct.LOIC DL305

Direct.LOIC DL405

Productivity Controller Overview

Productivity 3000

Universal Field I/O

Software

C-More HMI

C-More Micro HMI

ViewMarq Industrial Marquees

Other HMI

Communications

Appendix Book 1

Terms and Conditions

DL05: Powerful and Only \$125.00

Top eight reasons to choose a DL05 micro PLC for discrete control applications (and we've even added a little motion control!)

What is it?

For small I/O applications, the DL05 can do the job of some of our larger PLCs.

What's it got?

- Eight inputs and six outputs (integrated)
- Six I/O models of AC, DC and relay I/O
- 2K program memory
- 4K data memory
- Over 250 instructions, including four PID loops
- Powerful functions like FOR/NEXT loops, subroutines, and drum sequencers
- Removable terminal block

What discrete control can I perform with it?

- Control a small material positioning machine using built-in high-speed counting or pulse output I/O for cut-to-length, pick-and-place, speed monitoring, and more.
- Create a sequence controller using the drum instruction and discrete I/O for piece counting, sortation, stamping, filling, level control, and more.
- Build an events recorder using sensors and discrete I/O with the real-time clock option module installed.
- Use the 10-30 VDC-powered units in remote locations for data monitoring and control.

1 Low prices, starting at \$125.00

The DL05 micro PLC offers incredible features at a disposable price.

2 Practical communications

Two RS-232 serial communication ports are included on all models. This allows connectivity to an operator interface and networking with an AC drive or another PLC at the same time. The DL05 also supports industry standard Modbus RTU protocol (both master and slave on Port 2 up to 38.4K baud). Or, if you need additional ports, check out the D0-DCM module with connection speed up to 115.2 Kbps.



Two built-in RS-232 serial communication ports. Port 2 configurable up to 38.4K baud and supports master/slave on DirectNET and Modbus RTU.

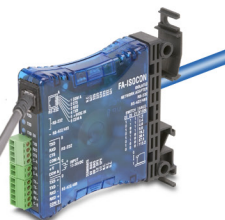

FA-ISOCON



Built-in high-speed counting and pulse output I/O

3 Simple high-speed counting or pulse output built in (on specific models)

The DL05 includes built-in configurable high-speed I/O. There's no need to purchase a separate motion controller or programmable limit switch (PLS) if your application only includes one simple motion requirement. For motion control on a budget, consider one of these options already included in the DL05:

- 5 kHz max. inputs for two up-only counters or one quadrature encoder
- One external interrupt input or pulse catch input (minimum pulse width 100 μSec)
- One 7 kHz maximum pulse output (step and direction or clockwise and counter clockwise pulse outputs selectable)

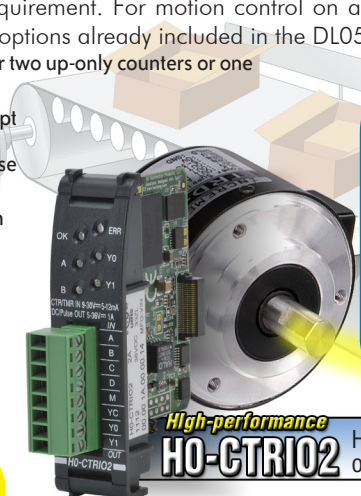

For higher resolution, use an HO-CTRIO2 option module:

- Inputs for two up or down counters, or one quadrature encoder (250 kHz max)
- Two high-speed inputs for edge timing, pulse catch, count reset/inhibit/capture or home search
- Two configurable high-speed outputs or one channel pulse output control (20 Hz-250 kHz)

\$199.00

High-performance HO-CTRIO2 High-speed counter option module



Modbus RTU master/slave communication to GS1 AC drive

FREE Software - PC-DS100 Simple programming for your applications

5 Our *DirectSOFT* (version 6.0) PLC programming software offers our traditional full package version, which will program every CPU in the *DirectLOGIC* series of PLCs for only \$395.00. The free PC-DS100 package has all the features of the full package, but restricts you to a 100-word program download. Many of our DL05, DL105 and DL06 customers are able to take advantage of the free programming software with its great features, like IBox instructions, configurable tool bars, dockable and floatable windows and more.

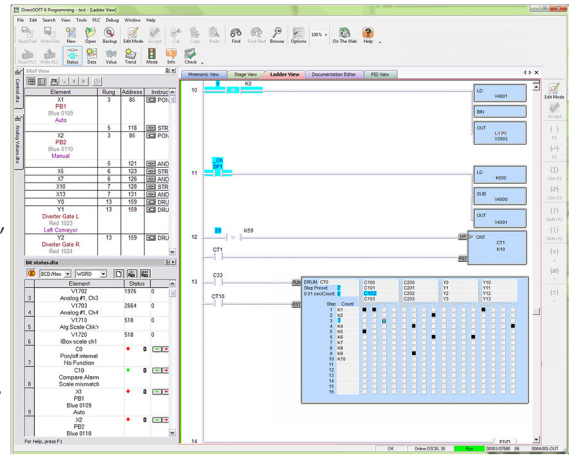

7 Expansion I/O using option modules

Add up to 16 more discrete I/O points by installing an option module. Choose from 12 different discrete modules, including DC in, AC in, DC out, DC in/out, and relay out, starting at only \$54.00.



6 Memory cartridge/real-time clock for only \$55.00

Install our D0-01MC into the option module slot and enable the DL05 for event scheduling. The D0-01MC also protects data during extended power removal with its on-board battery. Integrated upload and download buttons allow quick loading of a CPU program without the need for software.

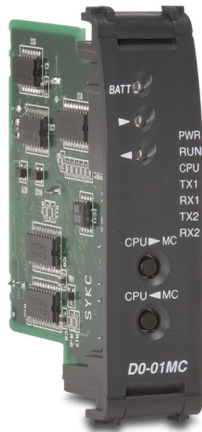

4 Easy connection to ZIPLink modules

The 16-point option modules can connect to a variety of *ZIPLink* modules, including the low-cost feedthrough terminals, optional fuse, LED and even *ZIPLink* relay modules. The powerful 10 amp *ZIPLink* relay system will allow a DL05 to connect to high-current loads like contactors, solenoids and hydraulic valves. (See *ZIPLinks*, our "five-second wiring solution." in the Wiring Solutions section)



8 Connectivity to the most popular networks

For as little as \$100.00, implement advanced networking solutions for the DL05 with our *DeviceNet* Slave Module, *Ethernet* Communications Module or our *PROFIBUS* Slave Communications Module. The D0-DCM module supports *DirectNet* and Modbus (slave) protocols.

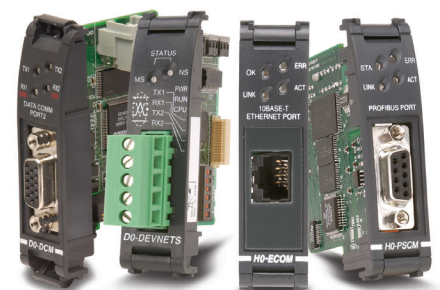

Modbus DeviceNet Ethernet PROFIBUS
(Modbus TCP)

D0-10ND3 10-pt. DC In.....	\$54.00
D0-10TD1 10-pt. DC Out.....	\$63.00
D0-10ND3F 10-pt. Fast Response.....	\$62.00
F0-08NA-1 8-pt. AC In.....	\$50.00
D0-10TD2 10-pt. DC Out.....	\$63.00
D0-08CDD1 4-pt. DC In/4pt DC Out.....	\$64.00
F0-08SIM Simulator.....	\$37.00

D0-07CDR 4-pt. DC In/3pt Relay Out.....	\$64.00
D0-08TR 8-pt. Relay Out.....	\$64.00
F0-04TRS 4-pt. Isolated Relay.....	\$41.00
D0-16ND3 16-pt. DC In.....	\$58.00
D0-16TD1 16-pt. DC Out.....	\$64.00
D0-16TD2 16-pt. DC Out.....	\$64.00

DL05 Expands To Support Analog

Top six reasons to choose a DL05 micro PLC for analog control

What is it?

The DL05's analog capabilities are a great fit for a variety of applications at a fraction of the competition's price. Install one of our analog option modules and wire directly to the most common analog devices, such as pressure and level transmitters, proportional valves, AC drives and panel meters.

What's it got?

- Four PID loops with auto-tune
- A large selection of analog option modules
- Signal ranges of 4-20 mA or 0-20 mA, and 0-5 V or 0-10 V input and output ranges available
- 12 or 16-bit resolution modules
- Thermocouple and RTD temperature inputs
- Removable terminal blocks available on all modules

What type of analog control can I perform with it?

- Build a micro process controller using the PID loops combined with one of the analog option modules. Add a local operator interface to set and view parameters.
- Monitor and control the level of a remote tank, well, or pumping station by combining a DL05 with our industrial telephone modem.
- Create a Modbus RTU network of several DL05 PLCs, each with an analog option module, for a low cost distributed control system. Even incorporate a PC HMI on the same network for a complete SCADA system.

1 Really low prices

Combine a \$83.00 4-channel analog input module with our \$125.00 DL05 PLC for low-cost analog monitoring. Use the built-in PID loops and build a micro process control system at an unbeatable price. The DL05 matches or beats the competition in features, then finishes them off with two-for-one pricing. And if you want to do a little analog control, use a combo 2-channel in/2-channel out analog module (\$155.00).

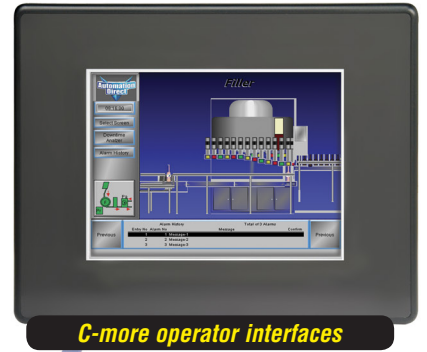

2 Practical built-in connectivity

With two RS-232 serial communication ports included, this little PLC is no silent black box. Connect an operator interface on Port 1, then connect Port 2 to a PC-HMI or other serial device for data acquisition or operator control at the same time. Supports industry standard Modbus RTU protocol (both master and slave on Port 2 up to 38.4K baud).



PC-DS100 - Free programming software includes all of the full package features like graphical PID loop trending.

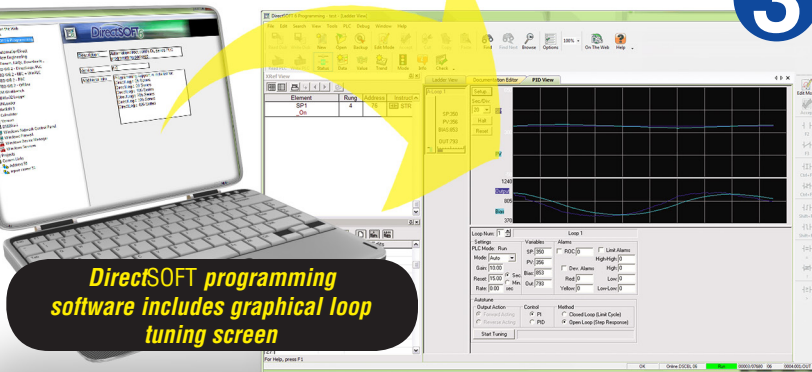

3

The DL05 complements its great analog capabilities with four PID loops included at no additional charge. It also features:

- Automatic loop scheduling
- Fill-in charts for alarms and ramp/soak profiles
- **DirectSOFT** programming software includes the loop tune screen with trending
- Auto-tune feature to allow the CPU to determine the near-optimum loop settings (based upon the time constant of your process at the time auto-tune procedure is performed)

DirectSOFT programming software includes graphical loop tuning screen

Industrial DIN-rail mount premium telephone modem (MDM-TEL \$450.00)



Program, troubleshoot, or collect data over the telephone line via our industrial modem

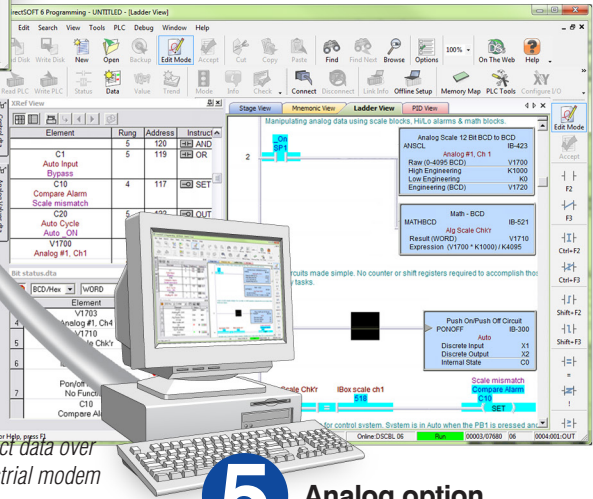

5

Analog option modules

These little analog modules save you space and money. We have thirteen models to choose from, with flexible features including 4-20 mA or 0-20 mA, and 0-5V or 0-10V input and output ranges along with modules accepting temperature input.

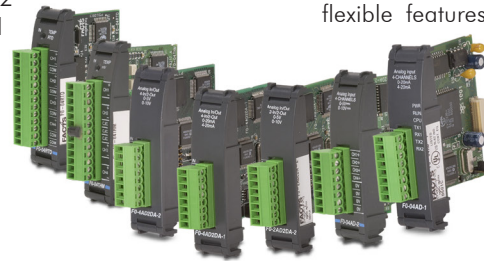

High resolution DL05/06 16-bit high-resolution modules are available in 4-channel or 8-channel out, and 8-channel in with either current voltage or voltage signal types.

4

RTU system when combined with our industrial modem

Combine a DL05 AC- or DC-powered unit with our industrial telephone modem and avoid the high cost of an advanced Remote Telemetry System (RTU) that probably has a PLC as its brain anyway. With its configurable Port 2 timing settings, the DL05 easily accommodates our industrial telephone modem for almost any remote dial-up application, such as pump stations, level control and monitoring, even golf course irrigation. This combination can really save you money on service calls, data acquisition, up-and-down-time trending and more.

6

Low-cost process control system

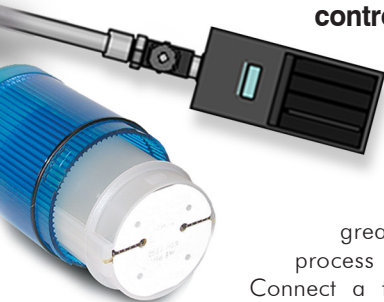

The small size and flexible features of the DL05 make it a great low-cost process controller.

Connect a temperature sensor to an analog input through an option module. Then, allow the DL05 discrete outputs to control process loads like heater elements and/or mixers using "time-proportioning" and the built-in PID.

Analog I/O Modules	AutomationDirect DirectLogic DL05	vs.	Allen-Bradley MicroLogix 1200	GE Fanuc VersaMax Micro
Analog Input				
4-channel	\$83.00 (0-04AD-1)		\$383.00 (1762-1F4)	N/A
Combination Analog Input/Output				
2-channel In/1-channel Out	N/A		N/A	\$675.00 (IC200UAL009, Integrated)
2-channel In/2-channel Out	\$155.00 (0-2A02DA-2)		\$383.00 (1762-1F20F2)	N/A
2-channel In/2-channel Out	\$192.00 (0-4A02DA-1)		N/A	N/A

All prices are U.S. published prices. AutomationDirect prices as of 4/27/2016. Allen-Bradley prices are from www.ab.com.com 4/18/2016. GE Fanuc prices are from www.automationdirect.com 4/18/2016.

DL06 - The Mighty Micro

From 36 to 100 I/O, starting at only \$251.00

What is it?

Our DL06 combines its fixed I/O of 20 inputs and 16 outputs with four option module slots for expansion (discrete, analog, temperature, communication modules), all in the same package. With the DL06, you can use the same PLC panel layout for all applications from 36 to 100 I/O.

What's it got?

- 14.8K of total memory
- Over 275 instructions, including 8 PID loops
- Two communication ports, including RS-232/422/485 capability
- Supports integrated networking for Modbus RTU master/slave, and ASCII in/out
- Integrated high-speed inputs or pulse output (on select models)
- Built-in real-time clock/calendar
- Optional LCD display for operator display or maintenance troubleshooting
- Ethernet, DeviceNet, PROFIBUS, Modbus option modules
- High-speed counter/pulse output option module

\$83.00 Optional LCD Display

Add operator display capability right on the PLC with this optional LCD display featuring:

- Two rows x 16 characters backlight display
- Large 14-point characters for easy readability
- Seven function keys
- Programmable user messages and alarms from within your ladder logic program
- Set time/date with password functions from keypad



Micro PLCs

	AutomationDirect DL06	VS.	Allen-Bradley MicroLogix 1100	Allen-Bradley MicroLogix 1200	GE Fanuc VersaMax Micro
Integrated I/O	20		10 (+2 analog)	24	16
Inputs	16		6	16	12
Outputs	100 I/O		80 I/O	136 I/O	140 I/O
Total I/O with Expansion	14.8K		8K	6K	9K
Total Program/Data Memory	Yes		No	Yes	Yes
Removable Terminal Block	Yes		Yes (serial and Ethernet)	Yes	Yes
Integrated Networking Port	Yes		Yes	Yes	Yes
Modbus RTU Master/Slave	Yes		Yes	Yes	No (Slave only)
ASCII In/Out	Yes		Yes	Yes	Yes
Integrated Real Time Clock	Yes		Yes	Yes	Yes
Integrated Operator Interface	Yes (Optional \$83.00)		Yes	No	No
DeviceNet Slave Module	Yes (\$100.00)		Yes (\$342.00)	Yes (\$342.00)	No
PID	Yes (8-loops auto-tune)		Yes	Yes	Yes
Auxiliary 24VDC Power Supply	300mA		250mA (DC/DC only)	400mA	200mA
Price with AC Power Supply					
DC inputs/DC Outputs	\$251.00 (DO-06DD1)		No	No	No
DC inputs/Relay Outputs	\$272.00 (DO-06DR)		\$680.00 (1763-L16BWA)	\$862.00 (1762-L40BWA)	\$452.00 (IC200UDR005)
AC inputs/AC Outputs	\$314.00 (DO-06AA)		No	No	\$495.00 (IC200UA007)
AC inputs/Relay Outputs	\$293.00 (DO-06AR)		\$667.00 (1763-L16AWA)	\$893.00 (1762-L40AWA)	\$510.00 (IC200UAR028)

All prices are U.S. published prices. AutomationDirect prices as of 4/27/2016. Allen-Bradley prices are from www.plccenter.com 4/18/2016. Technical data from MicroLogix™ 1200 Programmable Controllers Bulletin 1762 Controllers and Expansion I/O User Manual, Publication 1762-UM001B-EN-P - November 2000. MicroLogix 1100 User Manual 1763-UM001A-EN-P September 2005. GE Fanuc prices are from www.automationwarehouse.com 4/18/2016. Technical data from GE Fanuc Series VersaMax Nano & Micro Controller Solutions GFA-196 50M 2/00.

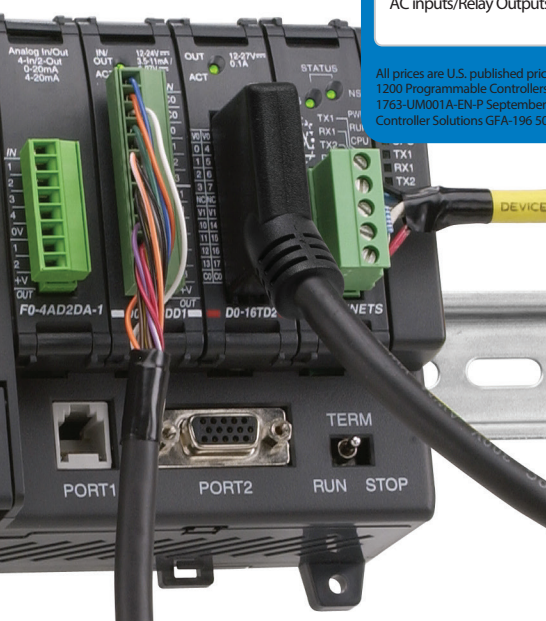

Micro PLC Modules	AutomationDirect DL06	VS.	Allen-Bradley MicroLogix 1100	Allen-Bradley MicroLogix 1200
Ethernet Communication Module	\$216.00 HD-ECOM100		Built in	\$1,120.00 Serial-to-Ethernet 1761-NET-EM
Thermocouple Input Module	\$207.00 FO-04THM 4-channel		\$534.00 1762-IT4 4-channel	\$534.00 1762-IT4 4-channel
RTD Input Module	\$207.00 FO-04RTD 4-channel		\$545.00 1762-IR4 4-channel	\$545.00 1762-IR4 4-channel

All prices are U.S. published prices. AutomationDirect prices as of 4/27/2016. Allen Bradley prices are from www.plccenter.com 4/18/2016.



22 mm pushbuttons starting at \$6.50 (non-illuminated)

22 mm indicating lights starting at \$5.50



- Company Information
- Control Systems Overview
- CLICK PLC
- Do-More PLCs Overview
- Do-More H2 PLC
- Do-More T1H PLC
- DirectLOGIC PLCs Overview
- DirectLOGIC DL05/06
- DirectLOGIC DL105
- DirectLOGIC DL205
- DirectLOGIC DL305
- DirectLOGIC DL405
- Productivity Controller Overview
- Productivity 3000
- Universal Field I/O
- Software
- C-More HMI
- C-More Micro HMI
- ViewMarq Industrial Marquees
- Other HMI
- Communications
- Appendix Book 1
- Terms and Conditions

DL06 - For Practical On/Off Control

Check out the top six reasons why the DL06 is a great fit for discrete applications



DO-06DD1 \$251.00
DC in/DC out/AC supply



DO-06DD2 \$251.00
DC in/DC out/AC Supply



DO-06DR \$272.00
DC in/Relay out/AC supply



DO-06DA \$293.00
DC in/AC out/AC supply



DO-06AR \$293.00
AC in/Relay out/AC supply



DO-06AA \$314.00
AC in/AC out/AC supply



DO-06DD1-D \$251.00
DC in/DC out/DC supply



DO-06DD2-D \$251.00
DC in/DC out/DC supply



DO-06DR-D \$272.00
DC in/Relay out/DC supply

1 Thirty-six built-in I/O points on all models

All nine DL06 models include 20 inputs and 16 outputs for a total of 36 built-in discrete I/O in a variety of AC, DC and relay combinations. No need to spend money on a larger PLC to get the correct combination of AC, DC, or relay I/O needed for your application. Check out the rest of these I/O features:

- All DC inputs are sink/source capable
- Removable terminal blocks for easy wiring
- Standard M3 terminals suitable for common wire spades, lugs, etc.
- 300 mA 12/24 VDC auxiliary power supply included on AC models

2 Available in nine models

The DL06 PLC line includes nine models to choose from in both AC and DC powered models. With its wide range of power supply capabilities (100-240 VAC and 12-24 VDC), the DL06 won't need an additional transformer in most applications. This makes the DL06 a great fit for even high voltage, 220-240 VAC applications or remote 12 VDC applications, and everything in between.

3 Flexible programming

Our FREE DirectSOFT programming package, PC-DS100*, combined with the powerful DL06 instruction set, makes programming your application simple and affordable. Check out these features:

- Supports over 230 instructions, including IBox instructions, floating point math, FOR/NEXT loops, subroutines, immediate I/O, fill-in-the-blank ASCII in/out instructions and more
- Convenient features like compare contacts, bit-of-word addressing, and assignable nicknames make programming and troubleshooting simple
- Program in conventional ladder logic or use our RLL PLUS Stage programming, which combines the best of flowchart style programming with ladder logic.

* Maximum 100 word program size. For larger projects, see our full package, PC-DSoft6, which sells for \$395.00.



Direct SOFT6 Programming full package only \$395.00

4 Practical communications

The DL06 includes two serial communication ports on all models. Port 1 supports programming and operator interface connectivity, while Port 2 can be used for RS-232/422/485 networking, or ASCII in/out to other devices. This allows connectivity to an operator interface and networking to an AC drive or another PLC, all at the same time. Supports industry-standard Modbus RTU protocol (both master and slave on Port 2 up to 38.4K baud). Or, if you need additional ports, check out the D0-DCM module.

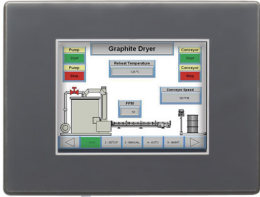

5 Discrete I/O option modules to mix and match

Starting at only \$41.00, these discrete I/O option modules allow the DL06 to expand with the needs of your application for just a few dollars more. Take a look at these features:

- Smallest I/O modules in its class
- Choose from 12 models
- Input, output and combination versions
- Removable terminal block
- ZIPLink compatible for 16-point versions

Actual sizes



Price check

D0-10ND3 10-pt. DC In.....	\$54.00
D0-10TD1 10-pt. DC Out.....	\$63.00
D0-10ND3F 10-pt. Fast Response.....	\$62.00
F0-08NA-1 8-pt. AC In.....	\$50.00
D0-10TD2 10-pt. DC Out.....	\$63.00
D0-08CDD1 4-pt. DC In/4pt DC Out.....	\$64.00
D0-07CDR 4-pt. DC In/3pt Relay Out.....	\$64.00
D0-08TR 8-pt. Relay Out.....	\$64.00
F0-04TRS 4-pt. Isolated Relay.....	\$41.00
D0-16ND3 16-pt. DC In.....	\$58.00
D0-16TD1 16-pt. DC Out.....	\$64.00
D0-16TD2 16-pt. DC Out.....	\$64.00
F0-08SIM 8-pt. Input Simulator.....	\$37.00

6 Easy connection to ZIPLink modules

The 16-point option modules can connect to a variety of ZIPLink modules, including low-cost feed-through terminals, and an optional fuse, LED, and even relay modules. Protect your valuable output devices by connecting the ZIPLink fuse modules to 16-point output option modules. Fuse modules include a fuse per point and a fuse per common for maximum protection, and all fuses are replaceable.

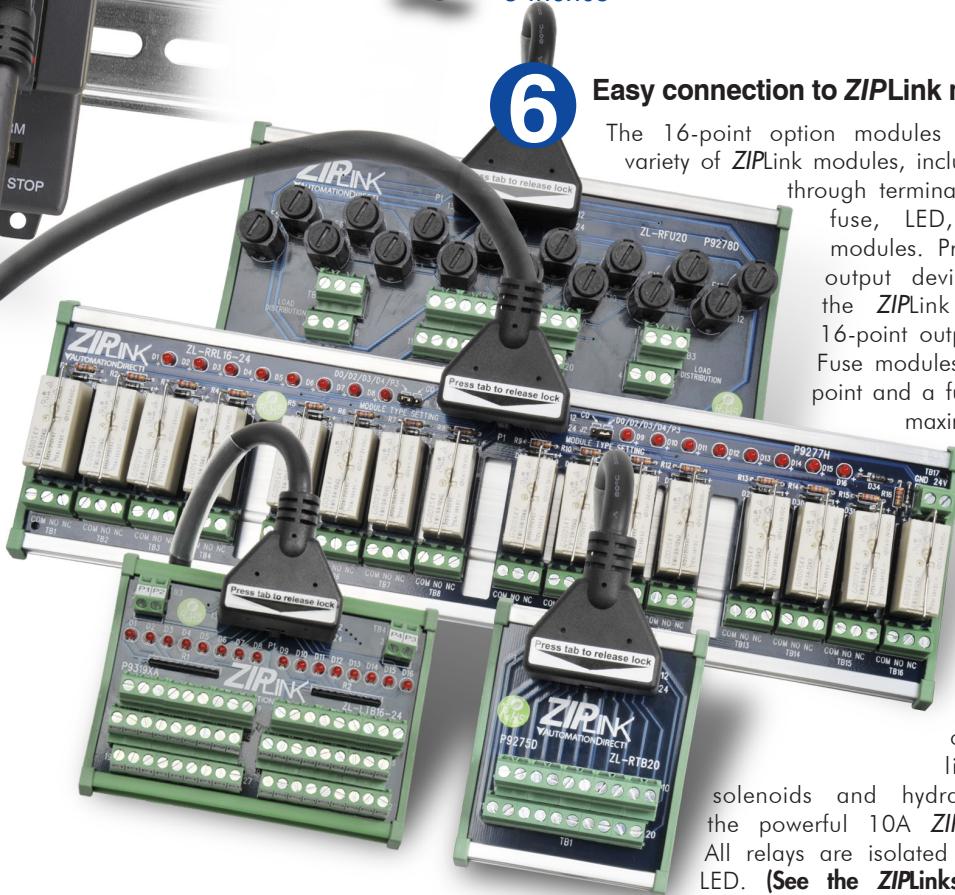

The convenient LED modules allow for easy status display of each connected 16-point input option module. Connect to high current loads like contactors, solenoids and hydraulic valves using the powerful 10A ZIPLink relay system. All relays are isolated and have a status LED. (See the ZIPLinks, our "five-second wiring solution." in the Wiring Solutions section)

DL06 - Great Fit For Flexible Analog Control

Top six reasons to use the DL06 for analog control

1 Two-for-one pricing

Combine these analog I/O modules with any DL06 for low cost analog control. You can buy two DL06 systems, with any one of our analog modules, for the price of one of our competitors' systems. Check out the chart at the bottom of this page to compare.

2 C-more panels offer a low-cost window into your application

Our *C-more* panels have some of the best features in the market for process HMI applications. Key features include a Factory Symbol Library, PID face-plates, recipe download objects, meters, trend graphs, bar graphs, and much more.

3 Direct wiring to the most common analog devices

With the analog option modules, the DL06 offers direct wiring to the most common analog devices such as pressure and level transmitters, proportional valves, AC drives, panel meters, etc.

- 4-20 mA, 0-20 mA, input and output ranges
- 0-5 V and 0-10 V input and output ranges
- All ranges jumper selectable

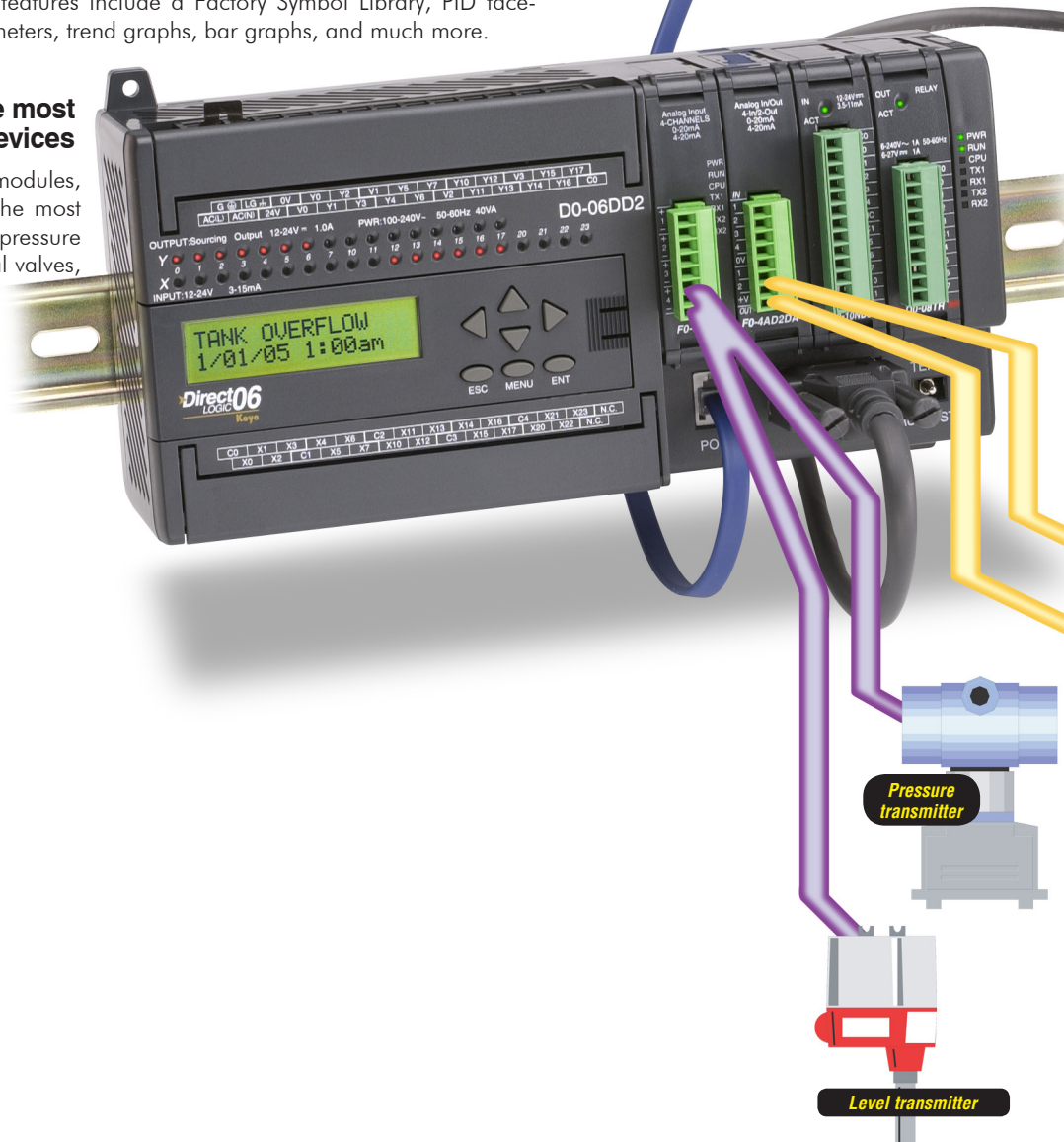

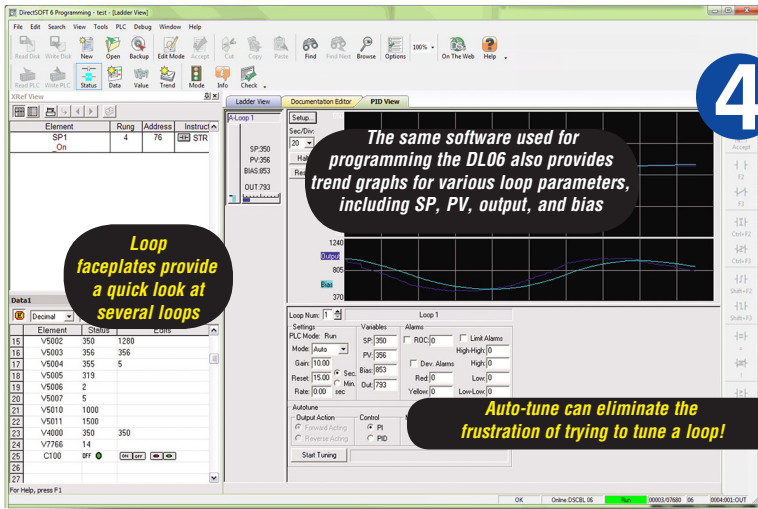

4

Eight PID loops with “auto-tune”

The DL06 supports its great analog capabilities with PID and floating point math at no additional charge. It also features:

- Automatic loop scheduling
- Charts to fill out for alarms and ramp/soak profiles
- **DirectSOFT** programming software includes the loop tune screen with trending (as shown)
- Auto-tune feature allows CPU to determine the near-optimum loop settings (based upon the time constant of your process at the time auto-tune procedure is performed)

Loop faceplates provide a quick look at several loops

The same software used for programming the DL06 also provides trend graphs for various loop parameters, including SP, PV, output, and bias

Auto-tune can eliminate the frustration of trying to tune a loop!

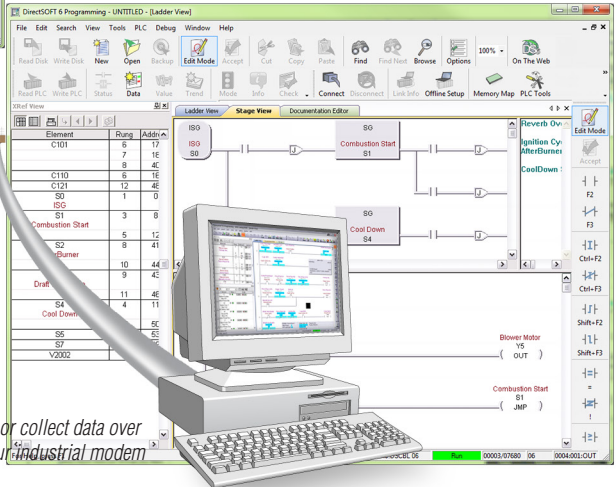

Program, troubleshoot, or collect data over the telephone line via our industrial modem



Industrial DIN rail mount premium telephone modem (MDM-TEL \$450.00)

5

Powerful built-in and expansion communication

Combine a DL06 AC or DC-powered unit with our industrial telephone modem and avoid the high cost of an advanced Remote Telemetry System (RTU) that probably has a PLC as its brain anyway. The DL06, with its configurable Port 2 timing settings, easily accommodates our industrial telephone modem for almost any remote dial-up application like pump stations, level control and monitoring and even golf course irrigation. This combination can really save you money on service calls, data acquisition, up-and-down-time trending and more. And if you need additional ports, check out the DO-DCM module.



Panel meter*

* product not currently sold by AutomationDirect

6

Our analog modules do not disappoint

These little analog modules save you space and money. There are thirteen models to choose from, with flexible features, including 4-20 mA or 0-20 mA, 0-5V or 0-10V input and output ranges, and high-resolution models. All ranges are jumper selectable and include removable terminal blocks.

High-Resolution



AC Drive

Price Check

F0-04AD-1 4 ch current in	\$83.00
F0-04AD-2 4 ch voltage in.....	\$120.00
F0-2AD2DA-2 2 ch in/2 ch out current ...	\$155.00
F0-4AD2DA-1 4 ch in/2 ch out current	\$192.00
F0-4AD2DA-2 4 ch in/2 ch out voltage.....	\$218.00
F0-08ADH-1 8 ch hi-res. in current	\$134.00
F0-08ADH-2 8 ch hi-res. in voltage	\$144.00
F0-08DAH-1 8 ch hi-res. out current	\$197.00
F0-08DAH-2 8 ch hi-res. out voltage	\$186.00
F0-04DAH-1 4 ch hi-res. out current	\$144.00
F0-04DAH-2 8 ch hi-res. out voltage	\$140.00

DL06 - For Communication-enabled Applications

Check out the top five reasons the DL06 is great for communication-enabled applications

1 Flexible communications ports, built right in!

The DL06 has two built-in communication ports for maximum flexibility. Network the DL06 to other PLCs, AC drives, or other compatible devices with multi-drop capability.

- Port 2 supports RS-232/422/485
- Master or slave capable
- Modbus RTU supports up to 247 nodes

2 Connect directly to the most common ASCII devices

Our DL06 allows you to easily perform ASCII operations at no additional charge! Check out these powerful features:

- Port 2 supports ASCII in or out on RS-232/422
- Error detection bits on both ASCII in and out transactions
- Data rates from 1,200 to 38.4K baud
- Simple programming within ladder logic
- Time/date stamps in three formats

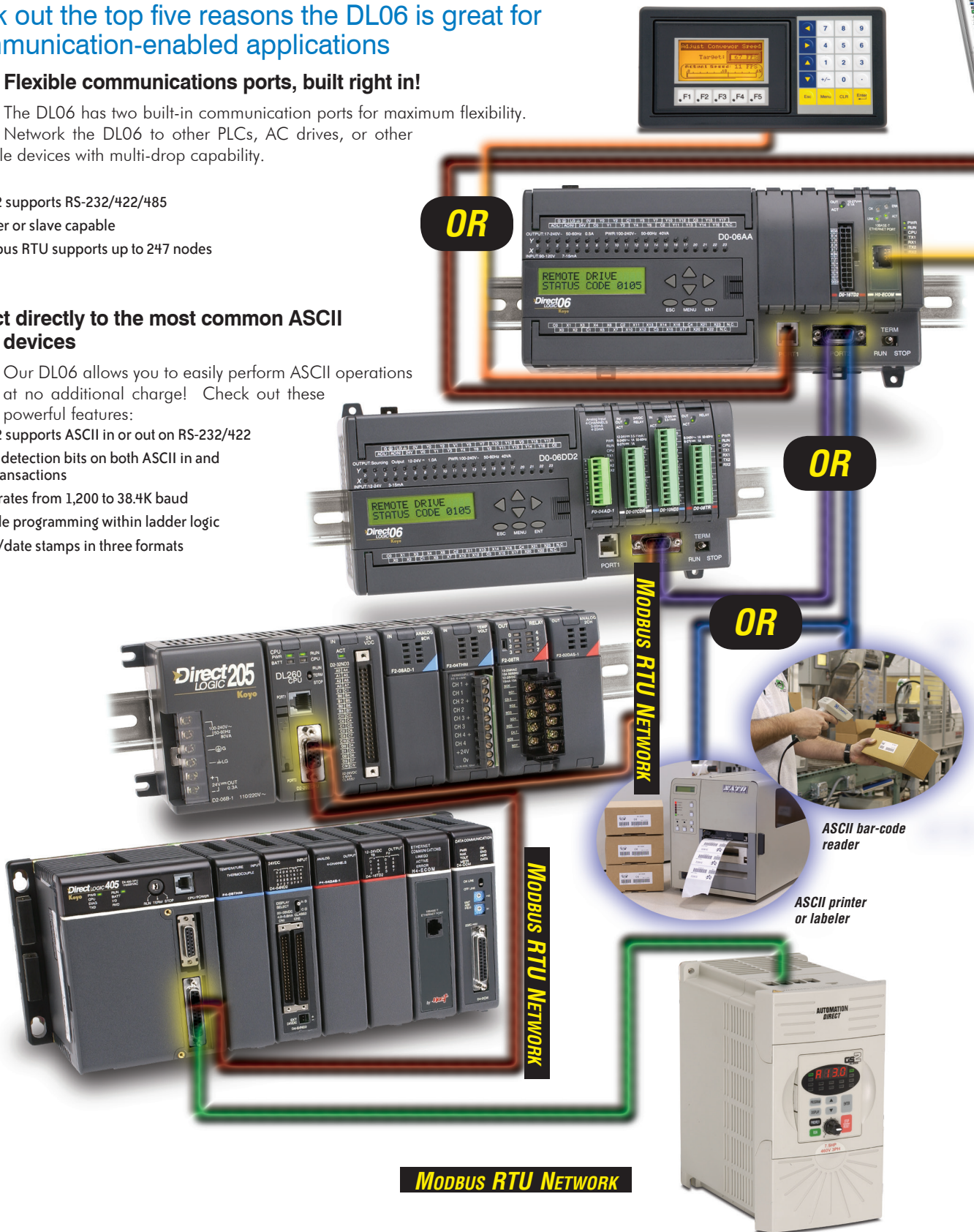

3 Programming port can also be used for operator interface

Port 1 on the DL06 is most often used for programming, but can also be used for an operator interface. After your programming is complete, use this port for one of our *C-more* panels as a low cost operator interface solution. You can leave Port 2 available for networking or other device control. The DL06 is also programmable over Ethernet with the optional H0-ECOM100 module.

4 Ethernet connectivity to PLCs and HMI/SCADA systems

The H0-ECOM100 Ethernet Communications Module provides a 100 Mbps Ethernet link for PLC systems and can be used for peer-to-peer PLC communication between two or more *DirectLOGIC* DL05/06 PLCs. It also provides data serving to HMI/SCADA and information systems using OPC over Ethernet. For simple data logging, *DataWorx* (see *Software* section) easily connects the DL06 via Ethernet to stand-alone PCs or network servers. Collect data without the need for special PC programming or any 3rd party HMI, SCADA, or DAQ software application.

5 Fill-in-the-blank instructions for ASCII and Modbus

The DL06 includes some cool communication instructions for ASCII operations and Modbus. Using *DirectSOFT* version 4.0 or higher, you can implement your communication requirements more easily than ever.



ETHERNET



Point of View HMI Software
or
DataWorx data collection software

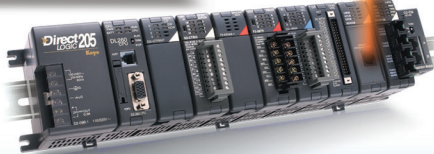

Check out some examples:

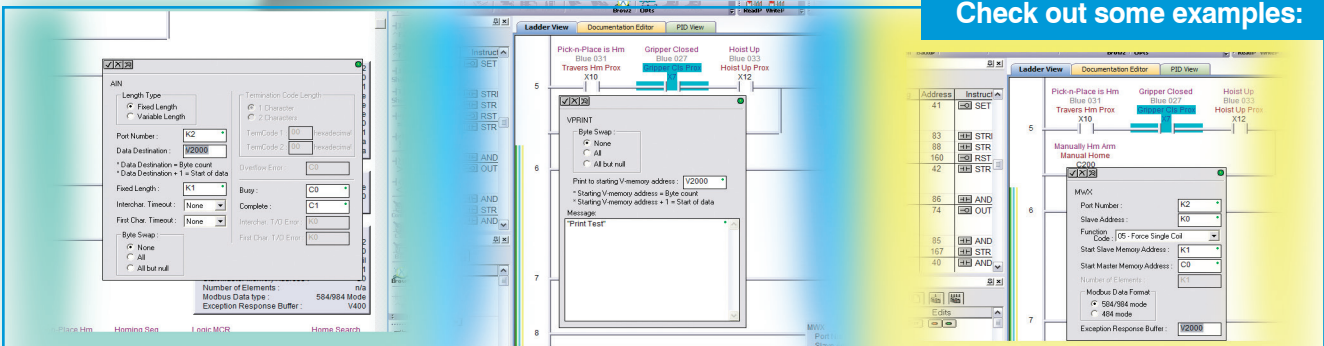

ASCII input made easy for text or numeric data

The DL06 supports several ASCII input capabilities on its Port 2 serial port, including raw ASCII strings and embedded ASCII via a supported protocol (Modbus, *DirectNET*, K-Sequence) from an external HMI or similar master. Interface your ASCII devices, like barcode readers, weigh scales, or embedded controllers to the DL06 using our simple 'AIN' instruction.

ASCII output for printers, labelers or any compatible serial interface

The DL06 also supports several ASCII output capabilities from its Port 2 serial port, including printing text strings, embedding memory register values in text strings, even time/date stamps in American, European and Asian formats. Add almost any compatible serial device to receive ASCII from the DL06, using our simple PRINT and VPRINT instructions.

Modbus RTU specific instructions

The DL06 also includes our Modbus instructions to allow the PLC to speak the industry standard Modbus RTU "language" of its connected device. Enter native Modbus addresses into your ladder program. No more calculating address conversions from *DirectLOGIC* V-memory addresses — just point, click, and enter your desired Modbus register number.

DL06 - For High-Speed Counting or Pulse Output on a Budget

With the DL06, there is no need to purchase a separate motion controller or programmable limit switch (PLS) if your application only includes one simple motion requirement. Check out some of the features we include at no extra charge (on select models), or for high-performance counting applications, use our H0-CTRIO2 module (\$199.00).



Pulse output for single-axis stepper/servo

Encoder input

OR

High-speed input for frequency, interrupt, or pulse catch

For the lowest cost motion control, consider one of these options already built into the DL06 I/O (on select models):

- 7 kHz max inputs for two up-only counters or one quadrature encoder
- One external interrupt input or pulse catch input (min pulse width 100 μ Sec)
- One 10 kHz max pulse output, step and direction, or clockwise (CW) and counter-clockwise (CCW) pulse outputs selectable

For higher performance, use the H0-CTRIO2 option module:

- Inputs for two up or down counters, or one quadrature encoder (250 kHz max)
- Two high-speed inputs for edge timing, pulse catch, count reset/inhibit/capture or home search
- Two configurable high-speed outputs or one channel pulse output control (20 Hz-250 kHz) step and direction, or clockwise (CW) and counter-clockwise (CCW) pulse outputs selectable

DL06: Snap-in LCD Display

Need a display to provide maintenance information in the control cabinet?

For only \$83.00 you can have a bright two-line LCD display right on the PLC:

- Two-line x 16-character display simply snaps into the face of the DL06. No cable or special mounting required!
- ESC, MENU and ENT keys, along with four arrow keys allow for easy and intuitive navigation
- Password protection capabilities available for system parameters like date and time
- Backlight can be turned off for bright locations



Two-line LCD display (DO-06LCD) \$83.00

User-defined LCD messages

You won't need to drag a laptop to your DL06 panel just to get a critical piece of information in a memory register or a PLC fault message. Simply program user-defined messages in ladder logic for display on the DL06 LCD message unit to show important values, events, alarms or faults (see the sample instruction at right). Let the LCD display direct the technician right to the problem so they can arrive with their tools in hand (instead of their laptop).

Text message from V-memory registers

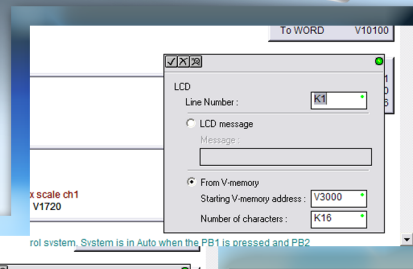

Messages with embedded time and date

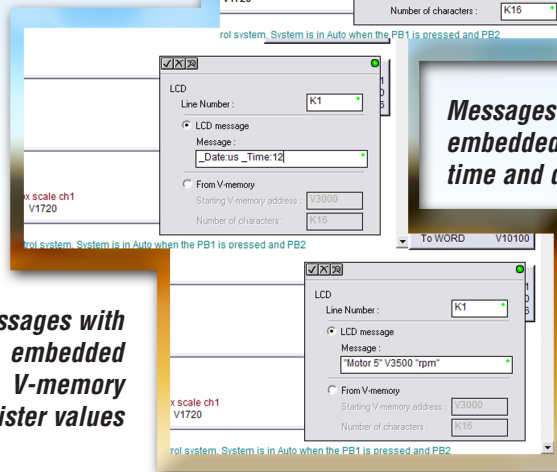

Messages with embedded V-memory register values

The DL05 & DL06 Family of Products

The DL05 micro PLC family includes eight different models. Each has eight inputs and six outputs in the base unit. The DL05 has one option module slot, which can be used to expand the I/O count, provide additional communications capability or add a real-time clock and battery back-up. The larger DL06 micro PLC family has 20 inputs and 16 outputs in the base unit. The DL06 has four option module slots which can be used to add I/O or provide additional communications options.

Instruction sets

The DL05 CPU offers PID capability, high-speed counting, and most of the same powerful instruction set as our popular D2-250-1 CPU, including the IBox instructions available in *DirectSOFT* version 6. All DL05 PLCs have two built-in RS-232 communications ports that can be used for programming, operator interface, networking, etc.

The DL06 CPU offers PID capability, floating point number handling, and an instruction set very similar to our D2-260 CPU, including the IBox instructions available in *DirectSOFT* version 6. All DL06 PLCs have two built-in communications ports that can be used for programming, operator interface, networking, etc. One of the DL06 ports is a multi-function port capable of RS-232, RS-422, or RS-485 communications.

Power options

The DL05 and DL06 families have AC and DC power options. They are also offered with a variety of I/O options. You can explore the Quick Selection Guide on the next page to choose the right PLC for your application.

High-speed inputs and outputs

Units with DC inputs have selectable high-speed input features on three input points (DL05) or four input points (DL06). Units with DC outputs can use the first two outputs as a single bi-directional pulse output. An overview of the high-speed I/O features appear later in this section.

DL05
8 in/6 out

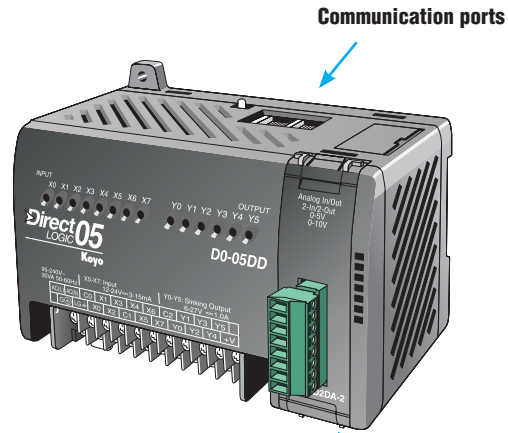

DL06
20 in/16 out

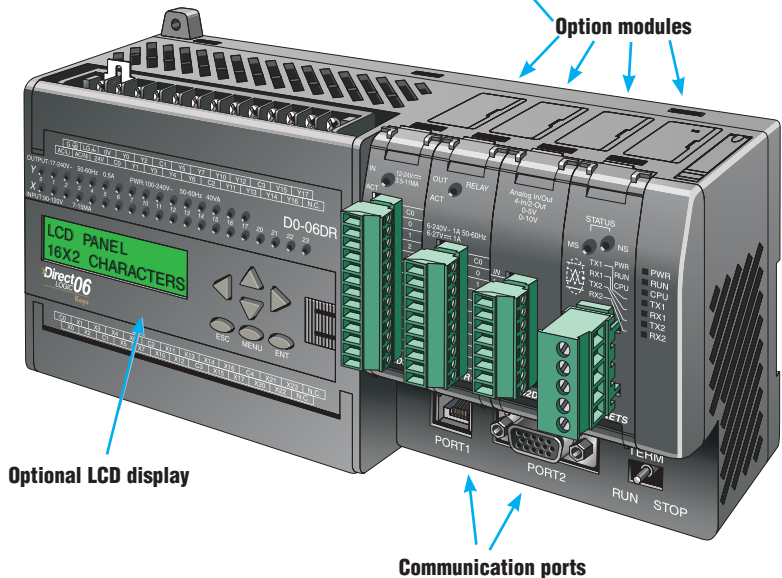

General Specifications	AC Powered	DC Powered
Power	110/220VAC (+ 10%, -15%), 50-60Hz	12/24VDC
Input Voltage Range	95-240VAC	12-24VDC
Maximum Power	30VA (DL05) 40VA (DL06)	20W
Maximum Inrush Current	13A, 1ms (240VAC)	10A < 1ms
Storage Temperature	-4°F to 158°F (-20°C to 70°C)	
Ambient Operating Temperature	32°F to 131°F (0°C to 55°C)	
Ambient Humidity	5% - 95% relative humidity (non-condensing)	
Vibration Resistance	MIL STD 810C, Method 514.2	
Shock Resistance	MIL STD 810C, Method 516.2	
Noise Immunity	NEMA (ICS3-304)	
Atmosphere	No corrosive gases	

Quick Selection Guide

Company Information

Control Systems Overview

CLICK PLC

Do-More PLCs Overview

Do-More H2 PLC

Do-More T1H PLC

DirectLOGIC PLCs Overview

DirectLOGIC DL05/06

DirectLOGIC DL105

DirectLOGIC DL205

DirectLOGIC DL305

DirectLOGIC DL405

Productivity Controller Overview

Productivity 3000

Universal Field I/O

Software

C-More HMI

C-More Micro HMI

ViewMarq Industrial Marquees

Other HMI

Communications

Appendix Book 1

Terms and Conditions

110/220 (+10%, -15%) VAC Power Options

DL05	DL06	DL06
<p>D0-05AA 8 AC inputs 6 AC outputs, 0.5A/point</p> <p>D0-05AD 8 AC inputs 6 DC outputs (sinking), 1.0A/point Two outputs can be used as a single bi-directional 7kHz pulse output</p> <p>D0-05AR 8 AC inputs 6 relay outputs, 2A/point</p> <p>D0-05DA 8 DC inputs Three inputs are filtered, or configure as a single 5kHz high-speed counter, interrupt input, or pulse catch input 6 AC outputs, 0.5A/point</p> <p>D0-05DD 8 DC inputs Four inputs are filtered, or configure as a single 5kHz high-speed counter, interrupt input, or pulse catch input 6 DC outputs (sinking), 1.0A/point Two outputs can be used as a single bi-directional 7kHz pulse output</p> <p>D0-05DR 8 DC inputs Four inputs are filtered inputs, can also be configured as a single 5kHz high-speed counter, interrupt input, or pulse catch input 6 relay outputs, 2A/point</p>	<p>D0-06AA 20 AC inputs 16 AC outputs, 0.5A/point</p> <p>D0-06AR 20 AC inputs 16 relay outputs, 2A/point</p> <p>D0-06DA 20 DC inputs Four inputs are filtered inputs, can also be configured as a single 7kHz high-speed counter, interrupt input, or pulse catch input 16 AC outputs, 0.5A/point</p>	<p>D0-06DD1 20 DC inputs Four inputs are filtered inputs, can also be configured as a single 7kHz high-speed counter, interrupt input, or pulse catch input 16 DC outputs (sinking), 1.0A/point* Two outputs can be used as a single bi-directional 10kHz pulse output</p> <p>D0-06DD2 20 DC inputs Four inputs are filtered inputs, can also be configured as a single 7kHz high-speed counter, interrupt input, or pulse catch input 16 DC outputs (sourcing), 1.0A/point Two outputs can be used as a single bi-directional 10kHz pulse output</p> <p>D0-06DR 20 DC inputs Four inputs are filtered inputs, can also be configured as a single 7kHz high-speed counter, interrupt input, or pulse catch input 16 relay outputs, 2A/point</p>

12/24 VDC Power Options

DL05	DL06	DL06
<p>D0-05DD-D 8 DC inputs Three inputs are filtered inputs, can also be configured as a single 5kHz high-speed counter, interrupt input, or pulse catch input 6 DC outputs (sinking), 1.0A/point Two outputs can be used as a single bi-directional 7kHz pulse output</p> <p>D0-05DR-D 8 DC inputs Three inputs are filtered inputs, can also be configured as a single 5kHz high-speed counter, interrupt input, or pulse catch input 6 Relay outputs, 2A/point</p>	<p>D0-06DD1-D 20 DC inputs Four inputs are filtered inputs, can also be configured as a single 7kHz high-speed counter, interrupt input, or pulse catch input 16 DC outputs (sinking), 1.0A/point* Two outputs can be used as a single bi-directional 10kHz pulse output</p> <p>D0-06DR-D 20 DC inputs Four inputs are filtered inputs, can also be configured as a single 7kHz high-speed counter, interrupt input, or pulse catch input 16 relay outputs, 2A/point</p>	<p>D0-06DD2-D 20 DC inputs Four inputs are filtered inputs, can also be configured as a single 7kHz high-speed counter, interrupt input, or pulse catch input 16 DC outputs (sourcing), 1.0A/point Two outputs can be used as a single bi-directional 10kHz pulse output</p> <p><i>Note: High speed outputs cannot be used if high-speed inputs are in use, and high-speed inputs cannot be used if high-speed outputs are in use. Analog inputs and outputs can be accommodated with option modules, which are available for both the DL05 and DL06.</i></p> <p><i>* These outputs must be derated to 0.6A for EN61131-2 compliance.</i></p>

Features at a Glance

The DL05 and DL06 micro PLCs are complete self-contained systems. The CPU, power supply, and I/O are all included inside the same housing. Option modules are available to expand the capability of each PLC family for more demanding applications. The standard features of these PLCs are extraordinary and compare favorably with larger and more expensive PLCs.

The specification tables to the right are meant for quick reference only. Detailed specifications and wiring information for each model of the DL05 and DL06 PLCs can be found in those specific sections.

Program capacity

Most boolean ladder instructions require a single word of program memory. Other instructions, such as timers, counters, etc., require two or more words. Data is stored in V-memory in 16-bit registers.

Performance

The performance characteristics shown in the tables represent the amount of time required to read the inputs, solve the Relay Ladder Logic program and update the outputs.

Instructions

A complete list of instructions is available at the end of this section.

Communications

The DL05 and DL06 offer powerful communication features normally found only on more expensive PLCs.

Special features

The DC input and DC output PLCs offer high-speed counting or pulse output. Option module slots allow for discrete I/O expansion, analog I/O, or additional communication options.

DL05 CPU Specifications

System capacity	
Total memory available (words)	6K
Ladder memory (words)	2,048
V-memory (words)	4,096
User V-memory	3,968
Non-volatile user V-memory	128
Battery backup	Yes ¹
Total built-in I/O	14
Inputs	8
Outputs	6
I/O expansion	Yes ¹

Performance	
Contact execution (Boolean)	0.7µs
Typical scan (1K Boolean) ²	1.5-3ms.

Instructions and diagnostics	
RLL ladder style	Yes
RLLPLUS/flowchart style (Stages)	Yes/256
Run-time editing	Yes
Supports Overrides	Yes
Scan	Variable/fixed
Number of Instructions	133
Types of Instructions:	
Control relays	512
Timers	128
Counters	128
Immediate I/O	Yes
Subroutines	Yes
For/next loops	Yes
Timed interrupt	Yes
Integer math	Yes
Floating-point math	No
PID	Yes
Drum sequencers	Yes
Bit of word	Yes
ASCII print	Yes
Real-time clock/calendar	Yes ¹
Internal diagnostics	Yes
Password security	Yes
System and user error log	No

Communications	
Built-in ports	Two RS-232C
Protocols supported:	
K-sequence (proprietary protocol)	Yes
DirectNet master/slave	Yes
Modbus RTU master/slave	Yes
ASCII out	Yes
Baud rate	
Port 1	9,600 baud (fixed)
Port 2	selectable 300-38,400 baud (default 9,600)

Specialty Features	
Filtered inputs	Yes ³
Interrupt input	Yes ³
High speed counter	Yes, 5kHz ²
Pulse output	Yes, 7kHz ²
Pulse catch input	Yes ³

- 1- These features are available with use of certain option modules. Option module specifications are located later in this section.
- 2- Our 1K program includes contacts, coils, and scan overhead. If you compare our products to others, make sure you include their scan overhead.
- 3- Input features only available on units with DC inputs and output features only available on units with DC outputs.

DL06 CPU Specifications

System capacity	
Total memory available (words)	14.8K
Ladder memory (words)	7680
V-memory (words)	7616
User V-memory	7488
Non-volatile user V-memory	128
Built-in battery backup (D2-BAT-1)	Yes
Total I/O	36
Inputs	20
Outputs	16
I/O expansion	Yes ¹

Performance	
Contact execution (Boolean)	0.6µs
Typical scan (1K Boolean) ²	1-2ms.

Instructions and diagnostics	
RLL ladder style	Yes
RLLPLUS/flowchart style (Stages)	Yes/1024
Run-time editing	Yes
Supports Overrides	Yes
Scan	Variable/fixed
Number of Instructions	229
Types of Instructions:	
Control relays	1024
Timers	256
Counters	128
Immediate I/O	Yes
Subroutines	Yes
For/next loops	Yes
Table functions	Yes
Timed interrupt	Yes
Integer math	Yes
Trigonometric functions	Yes
Floating-point math	Yes
PID	Yes
Drum sequencers	Yes
Bit of word	Yes
Number type conversion	Yes
ASCII in, out, print	Yes
LCD instruction	Yes
Real-time clock/calendar	Yes
Internal diagnostics	Yes
Password security	Yes
System and user error log	No

Communications	
Built-in ports:	One RS-232C
..... One multi-function RS232C/RS422/RS485	

NOTE: RS485 is for MODBUS RTU only.

Protocols supported:	
K-sequence (proprietary protocol)	Yes
DirectNet master/slave	Yes
Modbus RTU master/slave	Yes
ASCII in/out	Yes
Baud rate	
Port 1	9,600 baud (fixed)
Port 2	selectable 300-38,400 baud (default 9,600)

Specialty Features	
Filtered inputs	Yes ³
Interrupt input	Yes ³
High speed counter	Yes, 7kHz ²
Pulse output	Yes, 10kHz ²
Pulse catch input	Yes ³

- 1- These features are available with use of certain option module. Option module specifications are located later in this section.
- 2- Our 1K program includes contacts, coils, and scan overhead. If you compare our products to others, make sure you include their scan overhead.
- 3- Input features only available on units with DC inputs and output features only available on units with DC outputs.

Features at a Glance

DirectSOFT software

The DL05 and DL06 PLCs use the same familiar *DirectSOFT* programming software that our larger PLCs use. A FREE version of *DirectSOFT* gives you all the great features of the full version, but with a 100-word PLC program download limitation. For programs larger than 100 words, the full package is required. The FREE PC-DS100 software may be sufficient to program the DL05 and DL06. If you are programming with a full package version prior to v6.0, you will need v2.4 or later for the DL05 PLCs and v4.0 or later for the DL06. We always recommend the latest version for the most robust features. See the DirectLOGIC Overview section DL in this catalog for a complete description of *DirectSOFT* including features, part numbers of programming packages and upgrades.

Programming

Handheld programmer...D2-HPP	\$321.00
<i>DirectSOFT</i> Programming for Windows	
PC-DSOFT6	\$395.00
PC-DS100	Free
PC-R60-U (upgrade)	\$179.00

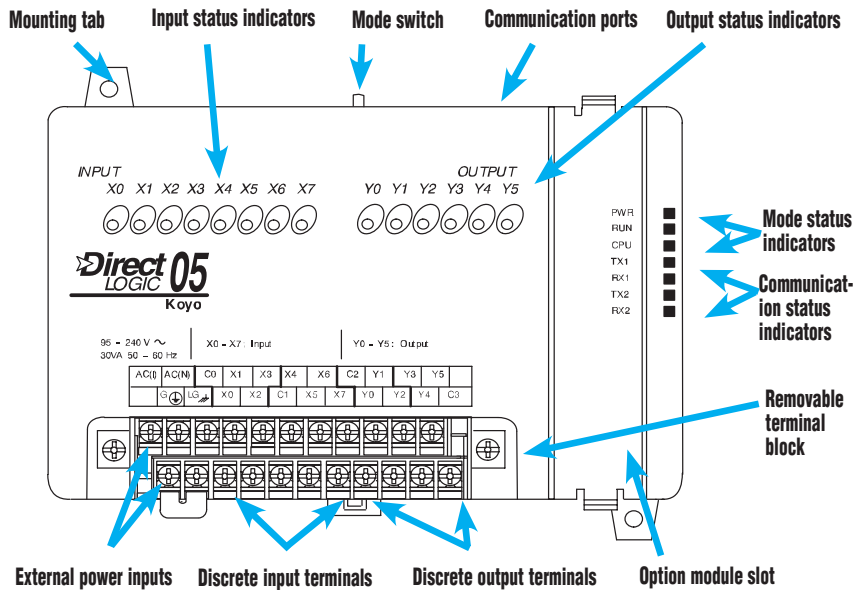

Hardware features diagrams

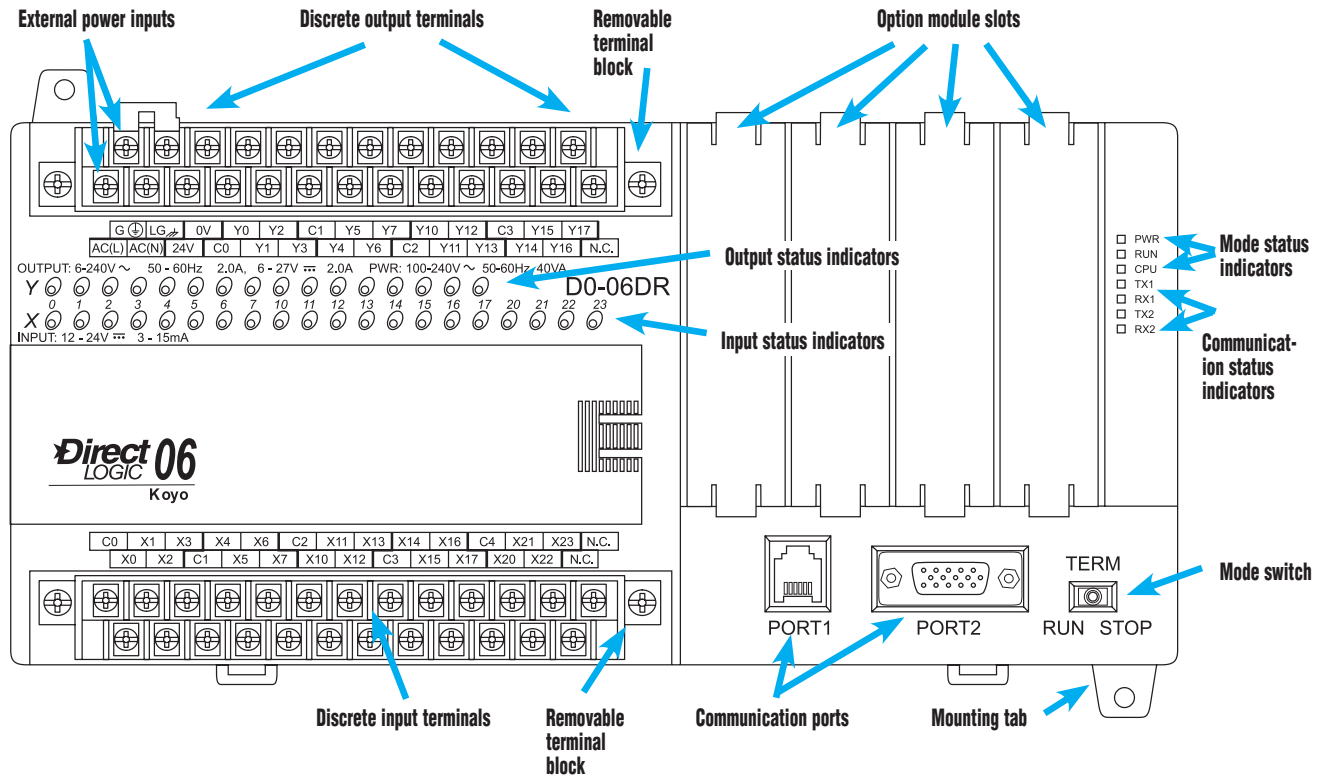

Company Information

Control Systems Overview

CLICK PLC

Do-More PLCs Overview

Do-More H2 PLC

Do-More T1H PLC

DirectLOGIC PLCs Overview

DirectLOGIC DL05/06

DirectLOGIC DL105

DirectLOGIC DL205

DirectLOGIC DL305

DirectLOGIC DL405

Productivity Controller Overview

Productivity 3000

Universal Field I/O

Software

C-More HMI

C-More Micro HMI

ViewMarq Industrial Marquees

Other HMI

Communications

Appendix Book 1

Terms and Conditions

Product Dimensions and Installation

It is important to understand the installation requirements for your DL05 or DL06 system. Your knowledge of these requirements will help ensure that your system operates within its environmental and electrical limits.

Plan for safety

This catalog should never be used as a replacement for the user manual. You can purchase, download free, or view online the user manuals for these products. The D0-USER-M is the publication for the DL05 PLCs, and the D0-06USER-M is the publication for the DL06 PLCs. The D0-OPTIONS-M is the user manual for the option modules. These user manuals contain important safety information that must be followed. The system installation should comply with all appropriate electrical codes and standards.

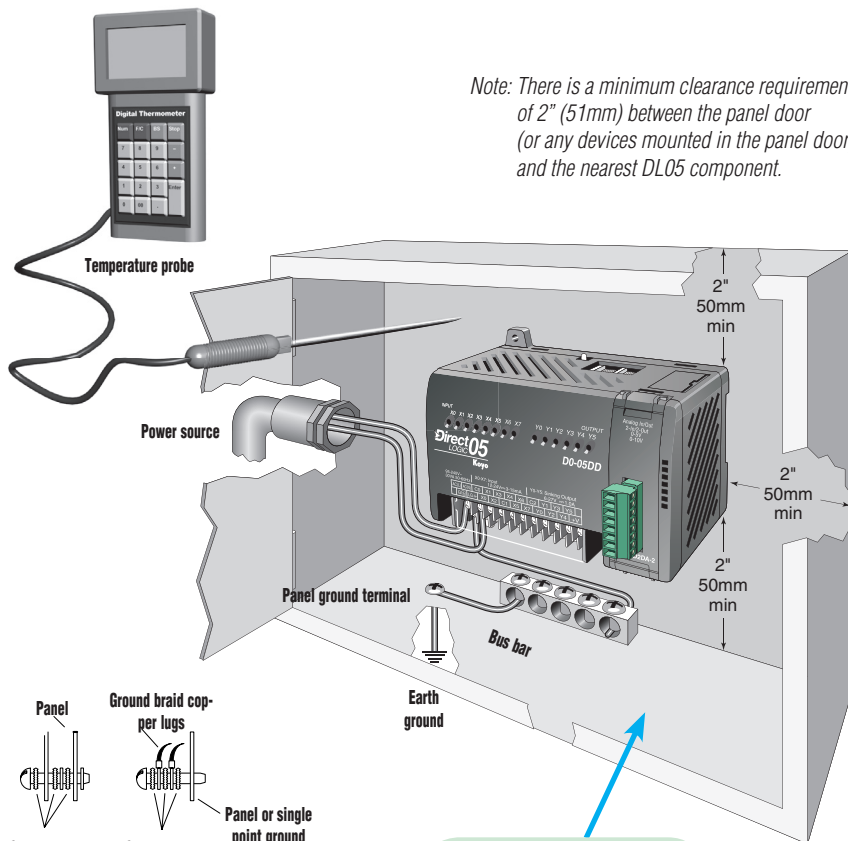

Note: There is a minimum clearance requirement of 2" (51mm) between the panel door (or any devices mounted in the panel door) and the nearest DL05 component.

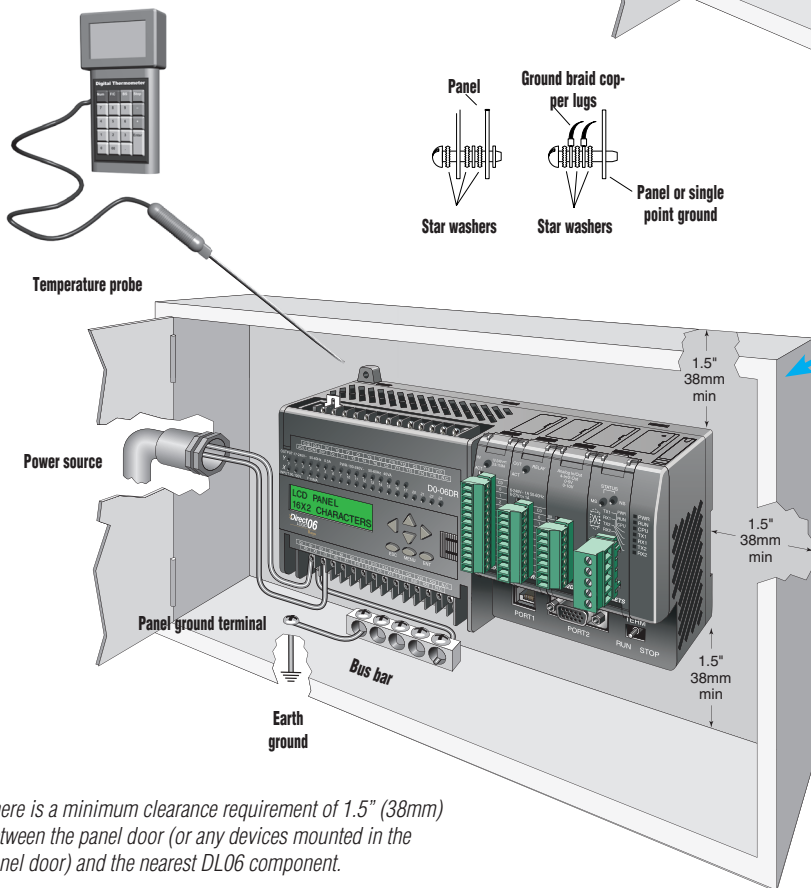

See the Enclosure section to find an enclosure that fits your application

Note: There is a minimum clearance requirement of 1.5" (38mm) between the panel door (or any devices mounted in the panel door) and the nearest DL06 component.

Environmental Specifications for DL05 and DL06	
Storage Temperature	-4° F-158°F (-20°C to 70°C)
Ambient Operating Temperature	32°F-131°F (0° to 55°C)
Ambient Humidity	5 to 95% relative humidity (non-condensing)
Vibration Resistance	MIL STD 810C Method 514.2
Shock Resistance	MIL STD 810C Method 516.2
Noise Immunity	NEMA (ICS3-304)
Atmosphere	No corrosive gases

Product Dimensions and Installation

Unit dimensions and mounting orientation

DL05 and DL06 PLCs must be mounted properly to ensure ample airflow for cooling purposes. It is important to follow the unit orientation requirements and to verify that the PLC's dimensions are compatible with your application. Notice particularly the grounding requirements and the recommended cabinet clearances.

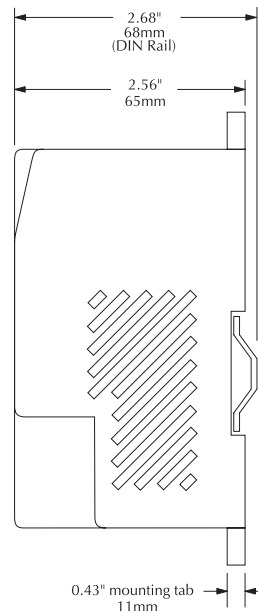
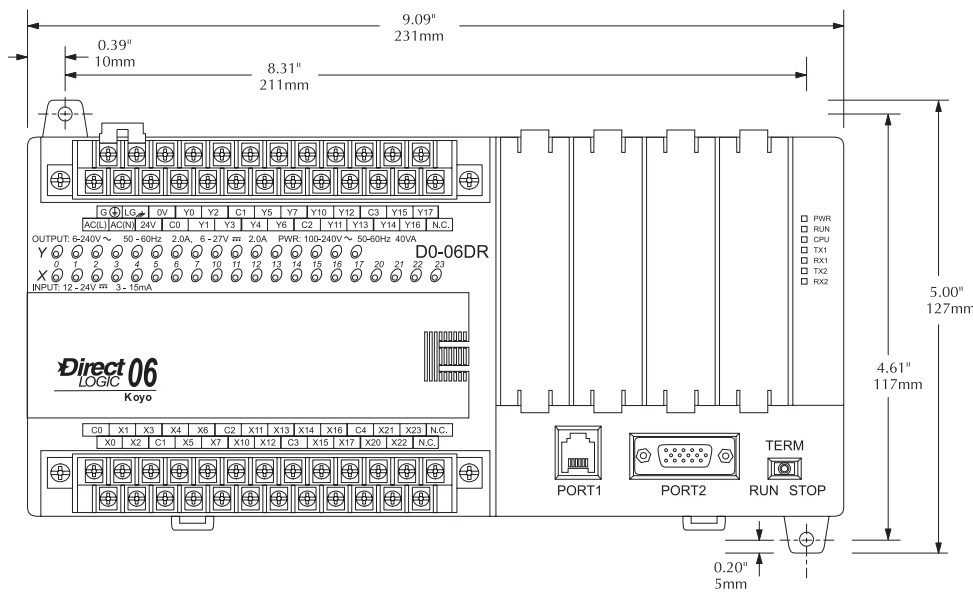
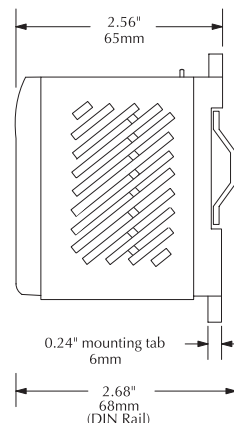
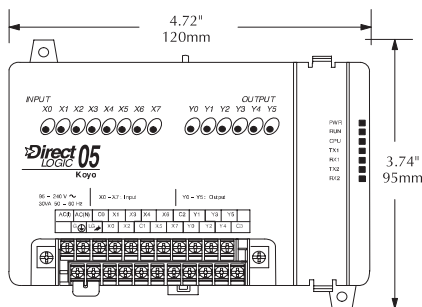
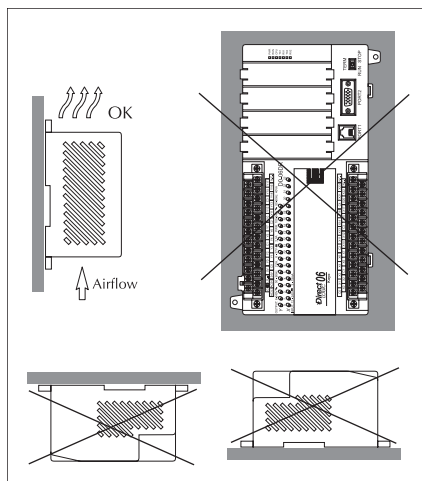
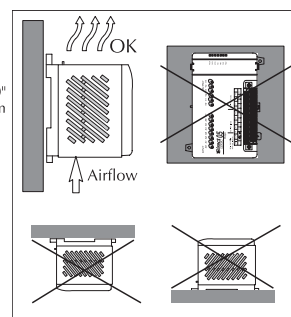
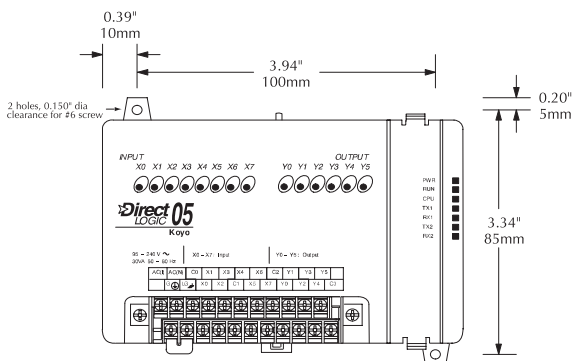

Company Information

Control Systems Overview

CLICK PLC

Do-More PLCs Overview

Do-More H2 PLC

Do-More T1H PLC

Direct LOGIC PLCs Overview

Direct LOGIC DL05/06

Direct LOGIC DL105

Direct LOGIC DL205

Direct LOGIC DL305

Direct LOGIC DL405

Productivity Controller Overview

Productivity 3000

Universal Field I/O

Software

C-More HMI

C-More Micro HMI

ViewMarq Industrial Marquees

Other HMI

Communications

Appendix Book 1

Terms and Conditions

Choosing the I/O Type

The DL05 and DL06 product families offer a number of different I/O configurations. Choose the configuration that is right for your application. Also, keep in mind that both the DL05 and the DL06 PLCs offer the ability to add I/O with the use of option modules.

Fixed discrete I/O

All DL05 micro PLCs have eight built-in inputs and six built-in outputs on the base unit. The DL06 micro PLCs have 20 built-in inputs and 16 built-in outputs on the base unit. We offer the most common I/O types for your convenience, including AC inputs and outputs, DC sinking and sourcing inputs and outputs, and relay outputs. Refer to the tables to the right to see the I/O combinations available and their voltage ranges.

Option module slots

The DL05 has one option module slot and the DL06 has four option module slots. Check out the discrete and analog I/O you can add by purchasing inexpensive option modules. Specialty modules are also available and are discussed later in this section.

Automatically assigned addresses

The DL05 uses automatic addressing, so for the vast majority of applications, there is no setup required. We use octal addressing for these products, which means there are no 8s or 9s. The DL05's eight input points use addresses X0-X7, and the six output points use addresses Y0-Y5. Similarly, the DL06 uses addresses X0-X23 and Y0-Y17.

Review the I/O specs and wiring diagrams

The Base Unit I/O tables give a brief description of the I/O combinations offered for the DL05 and DL06 PLCs. The I/O specifications are discussed in more detail later in this section.

DL05 Base Unit I/O Table							
Part Number	Inputs			Outputs			Price
	I/O type/ commons	Sink or source	Voltage ranges	I/O type/ commons	Sink or source	Voltage/current ratings	
DO-05AR	AC/2	N/A	90-120VAC	Relay/2	N/A	6-27VDC, 2A 6-240VAC, 2A	\$142.00
DO-05DR	DC/2	Sink or Source	12-24VDC	Relay/2	N/A	6-27VDC, 2A 6-240VAC, 2A	\$125.00
DO-05AD	AC/2	N/A	90-120VAC	DC/1	Sink	6-27VDC, 0.5A (Y0-Y1) 6-27VDC, 1.0A (Y2-Y5)	\$142.00
DO-05DD	DC/2	Sink or Source	12-24VDC	DC/1	Sink	6-27VDC, 0.5A (Y0-Y1) 6-27VDC, 1.0A (Y2-Y5)	\$125.00
DO-05AA	AC/2	N/A	90-120VAC	AC/2	N/A	17-240VAC 47-63Hz 0.5A	\$146.00
DO-05DA	DC/2	Sink or Source	12-24VDC	AC/2	N/A	17-240VAC 47-63Hz 0.5A	\$142.00
DO-05DR-D	DC/2	Sink or Source	12-24VDC	Relay/2	N/A	6-27VDC, 2A 6-240VAC, 2A	\$136.00
DO-05DD-D	DC/2	Sink or Source	12-24VDC	DC/1	Sink	6-27VDC, 0.5A (Y0-Y1) 6-27VDC, 1.0A (Y2-Y5)	\$136.00

Sinking/sourcing

If you are using a DC field device, you should consider whether that device requires a sinking or sourcing PLC I/O configuration. For more information on sinking and sourcing concepts, please refer to the Appendix of this catalog.

Sink/source inputs — All *built-in* DC inputs on the DL05 and DL06 micro PLCs can be wired in a sinking or sourcing configuration. However, all inputs on a single common must use the same configuration. In some cases, the DC inputs on option modules are fixed as sinking or sourcing. Refer to the table on the next page.

Sinking outputs — All *built-in* DC outputs on the DL05 are sinking. The DL06 family offers two PLCs with sinking DC outputs, and two with sourcing outputs.

Sourcing outputs — The DL06 PLC family includes the DO-06DD2(-D) with sourcing outputs. If a sourcing output is required, you might also consider using the DO-xxTD2 option module with sourcing outputs, which can also be installed in a DL05 or DL06 PLC.

High-speed inputs and pulse outputs

DL05s and DL06s with DC inputs offer high-speed input features, and DC output units offer pulse output features. The first three DC inputs on the DL05 PLCs are set up by default as filtered inputs with a 10 ms filter. Likewise, the first four DC inputs on the DL06 PLCs are set to the same default value. By entering a setup code in a special V-memory location, you can choose other features. In some modes of operation, you have a choice as to how you use each point. For example, if you use X0 as an up counter, you can use X2 as a reset input for the counter or as a filtered discrete input. If these features interest you, take a look at the detailed high-speed I/O descriptions found later in this section.

Choosing the I/O Type

DL06 Base Unit I/O Table							
Part Number	Inputs			Outputs			Price
	I/O Type/ Commons	Sink or source	Voltage Ranges	I/O Type/ Commons	Sink or Source	Voltage/Current Ratings	
DO-06AA	AC/5	N/A	90-120VAC	AC/4	N/A	17-240VAC, 0.5A 50/60 Hz	\$314.00
DO-06AR	AC/5	N/A	90-120VAC	Relay/4	N/A	6-27VDC, 2A 6-240VAC, 2A	\$293.00
DO-06DA	DC/5	Sink or source	12-24VDC	AC/4	N/A	17-240VAC, 0.5A 50/60Hz	\$293.00
DO-06DD1	DC/5	Sink or source	12-24VDC	DC/4	Sink	6-27VDC, 0.5A (Y0-Y1) 6-27VDC, 1.0A (Y2-Y17)*	\$251.00
DO-06DD2	DC/5	Sink or source	12-24VDC	DC/4	Source	12-24VDC, 0.5A (Y0-Y1) 12-24VDC, 1.0A (Y2-Y17)	\$251.00
DO-06DR	DC/5	Sink or source	12-24VDC	Relay/4	N/A	6-27VDC, 2A 6-240VAC, 2A	\$272.00
DO-06DD1-D	DC/5	Sink or source	12-24VDC	DC/4	Sink	6-27VDC, 0.5A (Y0-Y1) 6-27VDC, 1.0A (Y2-Y17)*	\$251.00
DO-06DD2-D	DC/5	Sink or source	12-24VDC	DC/4	Source	12-24VDC, 0.5A (Y0-Y1) 12-24VDC, 1.0A (Y2-Y17)	\$251.00
DO-06DR-D	DC/5	Sink or source	12-24VDC	Relay/4	N/A	6-27VDC, 2A 6-240VAC, 2A	\$272.00

Analog I/O

By using option modules, you can add analog inputs or outputs to your DL05 or DL06 PLC. The table below shows the input and output types at a glance. Detailed specifications are provided later in this section.

Analog I/O Option Modules					
Part Number	Inputs		Outputs		Price
	No.	Input Type	No.	Output Type	
FO-04AD-1	4	0-20mA or 4-20mA	0	N/A	\$83.00
FO-04AD-2	4	0-5VDC or 0-10VDC	0	N/A	\$120.00
FO-08ADH-1	8	0-20mA	0	N/A	\$134.00
FO-08ADH-2	8	0-5VDC or 0-10VDC	0	N/A	\$144.00
FO-04DAH-1	0	N/A	4	4-20mA	\$144.00
FO-08DAH-1	0	N/A	8	4-20mA	\$197.00
FO-04DAH-2	0	N/A	4	0-10VDC	\$140.00
FO-08DAH-2	0	N/A	8	0-10VDC	\$186.00
FO-4AD2DA-1	4	0-20mA or 4-20mA	2	0-20mA or 4-20mA	\$192.00
FO-2AD2DA-2	2	0-5VDC or 0-10VDC	2	0-5VDC or 0-10VDC	\$155.00
FO-4AD2DA-2	4	0-5VDC or 0-10VDC	2	0-5VDC or 0-10VDC	\$218.00
FO-04RTD	4	RTD	0	N/A	\$207.00
FO-04THM*	4	Thermocouple / Voltage	0	N/A	\$207.00

* See module specifications page for thermocouple types and voltage input ranges supported

Power budgeting

No power budgeting is necessary for the DL05. The built-in power supply is sufficient for powering the base unit, any of the option modules, the handheld programmer, and even a DV1000 operator interface.

Power budgeting is necessary for the DL06. With four option module slots and an optional LCD display, it is necessary to verify that sufficient power is available for all optional devices. Power budgeting is described in detail on page 2-29 and in the DL06 User Manual.

Discrete I/O Option Modules							
Part Number	Inputs			Outputs			Price
	I/O Type/ Number/ Commons	Sink or source	Voltage Ranges	I/O Type/ Number/ Commons	Sink or Source	Voltage/Current Ratings	
DO-07CDR	DC/4/1	Sink or source	12-24VDC	Relay/3/1	N/A	6-27VDC, 1A 6-240VAC, 1A	\$64.00
DO-08CDD1	DC/4/2	Sink or source	12-24VDC	DC/4/2	Sink	6-27VDC, 0.3A	\$64.00
DO-08TR	N/A	N/A	N/A	Relay/8/2	N/A	6-27VDC, 1A 6-240VAC, 1A	\$64.00
DO-10ND3	DC/10/2	Sink or source	12-24VDC	N/A	N/A	N/A	\$54.00
DO-10ND3F	DC/10/2	Sink or source	12-24VDC	N/A	N/A	N/A	\$62.00
DO-10TD1	N/A	N/A	N/A	DC/10/2	Sink	6-27VDC, 0.3A	\$63.00
DO-10TD2	N/A	N/A	N/A	DC/10/2	Source	12-24VDC, 0.3A	\$63.00
DO-16ND3	DC/16/4	Sink or source	20-28VDC	N/A	N/A	N/A	\$58.00
DO-16TD1	N/A	N/A	N/A	DC/16/2	Sink	6-27VDC, 0.1A	\$64.00
DO-16TD2	N/A	N/A	N/A	DC/16/2	Source	12-24VDC, 0.1A	\$64.00
FO-04TRS	N/A	N/A	N/A	Relay/4/4	N/A	5-30VDC, 3A 5-125VAC, 3A	\$41.00
FO-08NA-1	AC/8/2	N/A	80-132VAC 90-150VDC	N/A	N/A	N/A	\$50.00
FO-08SIM	8-pt. Input simulator						\$37.00

Communications and Specialty Option Modules		
Part Number	Description	Price
HO-ECOM100	Ethernet Communications Module 10/100 Mbit	\$216.00
DO-DEVNETS	DeviceNET Slave Module	\$100.00
HO-CTRIO	High Speed Counter I/O Module	Retired
HO-CTRIO2		Retired
HO-PSCM	Profibus Slave Communications Module	\$309.00
DO-DCM	Serial Communications Module	\$146.00
FO-CP128	ASCII CoProcessor Module	\$192.00

Networking the DL05 and DL06

All DL05 and DL06 PLCs have built-in networking capability. The DL05 family offers two 6-pin, RS-232 ports. You can use these ports for programming, networking, or connecting an operator interface device. The RS-232 ports support point-to-point communications using the optional D0-CBL cable. If you need to create a multi-drop network or require longer distances between devices, you can use the FA-ISOCOCON at each DL05 to convert the RS-232 signal to RS-422 or RS-485.

The DL06 family of PLCs offers even greater communications flexibility. Port 1 is a fixed baud rate port identical to port 1 on the DL05 PLCs, but port 2 is a multi-function port that can be used as RS-232, RS-422, or RS-485 (Modbus/ASCII only) without using external converters. This allows you to create multi-drop networks with minimal installation headaches.

Protocols supported

Each port is capable of communicating using K-sequence, *Direct*NET and Modbus RTU protocols. Port 1 can only be a slave for each of the protocols. Port 2 can serve as a K-sequence slave or a network master or slave for either *Direct*NET or Modbus RTU protocols.

Serial Bus Protocols

We also offer option modules that allow you to connect a DL05 or DL06 PLC to a variety of networks as a slave device. Our D0-DEVNETS (DeviceNet) and H0-PSCM (PROFIBUS) option modules plug into any DL05 or DL06 PLC. The D0-DCM Data Communications module supports *Direct*NET and Modbus RTU protocols.

ZIPLink communication adapter modules

The ZIPLink communications adapter modules offer fast and convenient screw terminal connection for the bottom port of the DL06 CPU. The adapter modules are RS232/422 DIP switch selectable and are offered with or without indicating LEDs and surge protection. See the Wiring Solutions section in this catalog for more information.

Optional Ethernet communication modules

Need to connect to a high speed HMI or computer system? We offer a 100Base-T Ethernet communications module. You can use the H0-ECOM100 Ethernet communication module with our Stride

Ethernet switches or with most off-the-shelf Ethernet hubs or switches. The H0-ECOM100 option module plugs into any DL05 or DL06 PLC and supports the industry standard Modbus TCP protocol.

Point-to-point

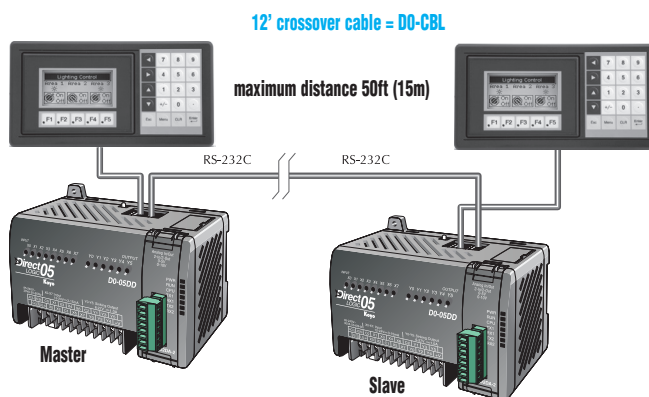

Multi-drop

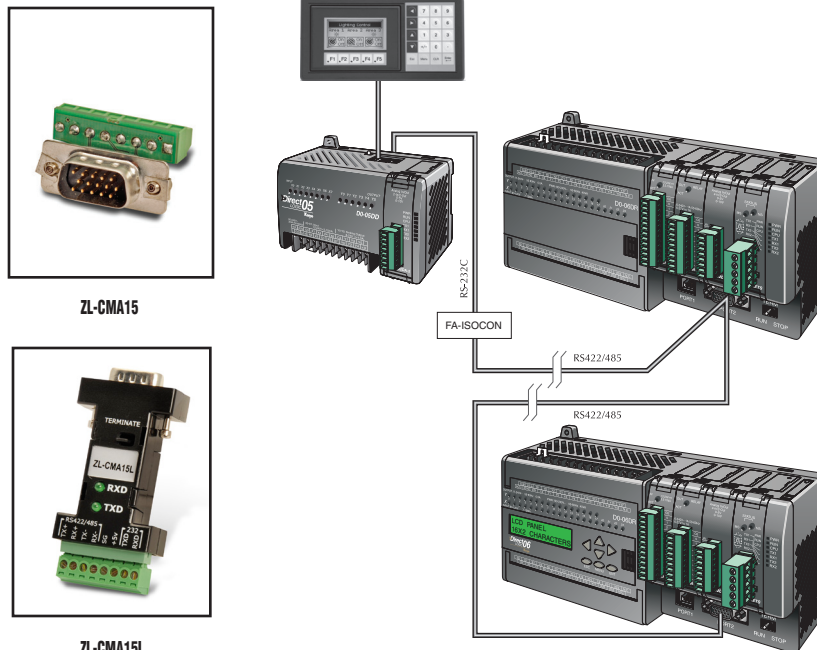

Maximum distance of 3,300 ft. (1000m)

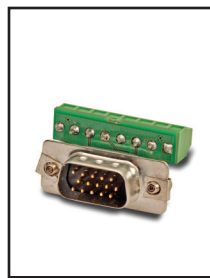

ZL-CMA15

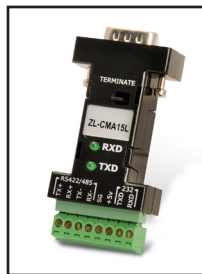

ZL-CMA15L

Ports, Status Indicators, and Modes

Port 1

Port 1 is a 6-pin, fixed configuration port and has the same pin assignments on the DL05 and the DL06. Please refer to the table and diagrams on this page. This port can be used to connect to an HPP, *DirectSOFT*, an operator interface, or other external device. Features include:

- 9600 baud
- 8 data bits
- Odd parity
- 1 start bit, 1 stop bit
- Station address of 1
- Asynchronous, half-duplex, DTE

Protocols supported (as slave):

- K sequence, *DirectNET*, Modbus RTU

DL05 & DL06 Port 1 Pin Descriptions		
1	0V	Power (-) connection (GND)
2	5V	Power (+) connection
3	RXD	Receive data (RS-232C)
4	TXD	Transmit data (RS-232C)
5	5V	Power (+) connection
6	0V	Power (-) connection (GND)

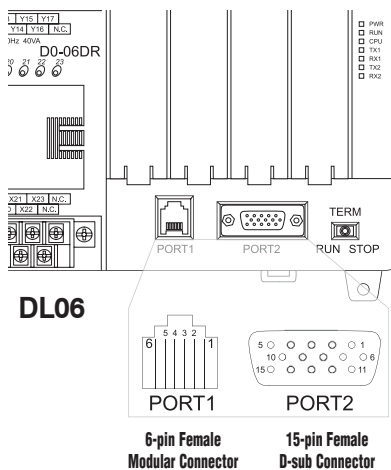
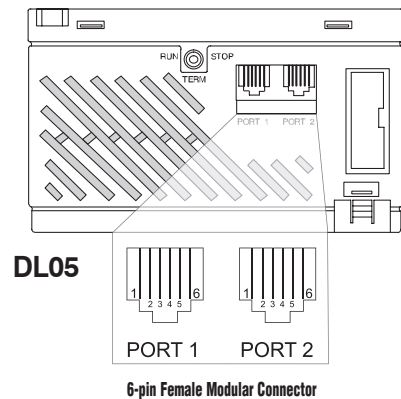

Port 2

Port 2 is a configurable port on both the DL05 and the DL06 PLCs. The DL05 PLC uses a 6-pin modular connector and offers RS-232 communications only. The DL06 PLC uses a 15-pin HD-sub connector and offers RS-232, RS-422, or RS-485 communications. Please refer to the table and diagrams on this page for more information. This port can be used to connect to an HPP, *DirectSOFT*, an operator interface, or other external device. Features of port 2 include:

- 300, 600, 1200, 2400, 4800, 9600 (default), 19,200, 38,400 baud
- 8 data bits
- Odd (default), even, or no parity
- 1 start bit, 1 stop bit
- Station address:
 - 1 (default)
 - 1-90 *DirectNET*, K sequence
 - 1-247 Modbus RTU
- Asynchronous, half-duplex, DTE

Protocols supported:

- K sequence (slave), *DirectNET* (master/slave), Modbus (master/slave)

DL05 Port 2 Pin Descriptions		
1	0V	Power (-) connection (GND)
2	5V	Power (+) connection
3	RXD	Receive data (RS-232C)
4	TXD	Transmit data (RS-232C)
5	RTS	Ready to send
6	0V	Power (-) connection (GND)

DL06 Port 2 Pin Descriptions		
1	5V	Power (+) connection
2	TXD	Transmit data (RS-232C)
3	RXD	Receive data (RS-232C)
4	RTS	Ready to send (RS232C)
5	CTS	Clear to send (RS232C)
6	RXD-	Receive data (-) (RS-422/485)
7	0V	Power (-) connection (GND)
8	0V	Power (-) connection (GND)
9	TXD+	Transmit data (+) (RS-422/485)
10	TXD-	Transmit data (-) (RS-422/485)
11	RTS+	Ready to send (+) (RS-422/485)
12	RTS-	Ready to send (-) (RS-422/485)
13	RXD+	Receive data (+) (RS-422/485)
14	CTS+	Clear to send (+) (RS-422/485)
15	CTS-	Clear to send (-) (RS-422/485)

DL05 and DL06 status indicators

Status Indicators		
Indicator	Status	Meaning
PWR	ON	Power good
	OFF	Power failure
RUN	ON	CPU is in Run Mode
	OFF	CPU is in Stop or Program Mode
CPU	ON	CPU self diagnostics error
	OFF	CPU self diagnostics good
TX1	ON	Data is being transmitted by the CPU-Port 1
	OFF	No data is being transmitted by the CPU-Port 1
RX1	ON	Data is being received by the CPU-Port 1
	OFF	No data is being received by the CPU-Port 1
TX2	ON	Data is being transmitted by the CPU-Port 2
	OFF	No data is being transmitted by the CPU-Port 2
RX2	ON	Data is being received by the CPU-Port 2
	OFF	No data is being received by the CPU-Port 2

DL05 and DL06 mode switches

Mode Switch Position	CPU Action
RUN (Run Program)	CPU is forced into the RUN mode if no errors are encountered. No program changes are allowed by the programming/monitoring device.
TERM (Terminal)	RUN PROGRAM and the TEST modes are available. Mode and program changes are allowed by the programming/monitoring device.
STOP	CPU is forced into the STOP mode. No changes are allowed by the programming/monitoring device.

Use the optional low profile 15-pin adapter to make option module wiring easier.

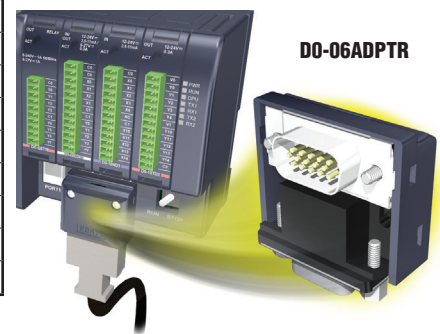

ASCII and Modbus Instructions

ASCII instructions for DL06

The DL06 PLC supports several easy-to-use instructions, which allow ASCII strings to be read into or written from the communication ports when using either the CPU port 2, or the D0-DCM Data Communications Module port 2.

Raw ASCII: CPU/DCM Port 2 can be used for either reading or writing raw ASCII strings, but not for both.

Embedded ASCII: With these instructions, you can use the DL06 PLC to locate ASCII strings embedded within a supported protocol via CPU/DCM Port.

Receiving ASCII strings

1. ASCII IN (AIN) - This instruction configures CPU/DCM Port 2 for raw ASCII input strings, with parameters such as fixed and variable length ASCII strings, termination characters, byte swapping options, and instruction control bits. Use barcode scanners, weigh scales, etc., to write raw ASCII input strings into CPU/DCM Port 2 based on the AIN instruction's parameters.

2. Write embedded ASCII strings directly to V-memory from an external HMI (or similar master device). The ASCII string is transmitted through CPU/DCM Port 2 using any supported communications protocol. This method uses the familiar RX/WX instructions previously available.

3. If the DL06 is used as a network master, the Network Read instruction (RX) can be used to read embedded ASCII data from a network slave device. Again, the ASCII string would be transmitted through CPU/DCM Port 2, using any supported communications protocol.

Writing ASCII strings

1. Print from V-memory (PRINTV) - Use this instruction to write raw ASCII strings out of CPU/DCM port 2 to a display panel, serial printer, etc.

The instruction features the starting V-memory address, string length, byte swapping options, etc. When the instruction's permissive bit is enabled, the string is written to CPU/DCM Port 2.

2. Print to V-memory (VPRINT) - Use this instruction to create pre-coded ASCII strings in the PLC (e.g. alarm messages). When the instruction's permissive bit is enabled, the message is loaded into a pre-defined V-memory address location. Then the PRINTV instruction can be used to write the pre-coded ASCII string out of CPU/DCM Port 2. American, European, and Asian Time/Dates stamps are supported.

3. Print Message (PRINT) - This existing instruction can be used to create pre-coded ASCII strings in the PLC. When the instruction's permissive bit is enabled, the string is written to CPU/DCM Port 2. The VPRINT/PRINTV instruction combination is more powerful and flexible than the PRINT instruction.

4. If the DL06 PLC is a network master, the Network Write (WX) can be used to write embedded ASCII data to an HMI or slave device directly from V-memory. This is done via a supported communications protocol using CPU/DCM Port 2.

More ASCII instructions

ASCII Find (AFIND) - Finds where a specific portion of the ASCII string is located in continuous V-memory addresses.

ASCII Extract (AEX) - Extracts a specific portion (usually some data value) from the ASCII find location or other known ASCII data location.

Compare V-memory (CMPV) - This instruction is used to compare two blocks of V-memory addresses and is usually used to detect a change in an ASCII string. Compared data types must be of the same format (e.g. BCD, ASCII, etc.).

Swap Bytes (SWAPB) - Swaps V-memory bytes on ASCII data that was written directly to V-memory from an external HMI or similar master device via a communications protocol. The AIN and AEX instructions have a built-in byte swap feature.

The F0-CP128 option module is also available for more extensive ASCII communications.

Modbus RTU instructions for DL06

The DL06 CPU/DCM port 2 supports Modbus Read/Write instructions that simplify setup. The MRX and MWX instructions allow you to use native Modbus addressing, eliminating the need for octal to decimal conversions.

Function Codes 05 and 06 and the ability to read Slave Exception Codes have been added. These flexible instructions allow the user to select the following parameters within one instruction window:

- 584/984 or 484 Modbus data type
- Slave node (0-247)
- Function code
- Starting master/slave memory address
- Number of bits
- Exception code starting address

Power Budgeting for the DL06

The DL06 has four option module slots. To determine whether the combination of modules you select will have sufficient power, you will need to perform a power budget calculation.

Power supplied

Power is supplied from two sources: the internal base unit power supply and, if required, an external supply (customer furnished). The D0-06xx (AC powered) PLCs supply a limited amount of 24 VDC power. The 24 VDC output can be used to power external devices.

For power budgeting, start by considering the power supplied by the base unit. All DL06 PLCs supply the same amount of 5 VDC power. Only the AC units offer 24 VDC auxiliary power.

Be aware of the trade-off between 5 VDC power and 24 VDC power. The amount of 5 VDC power available depends on the amount of 24 VDC power being used, and the amount of 24 VDC power available depends on the amount of 5 VDC power consumed. Determine the amount of internally supplied power from the table to the right.

Power required by base unit

Because of the different I/O configurations available in the DL06 family, the power consumed by the base unit itself varies from model to model. Subtract the amount of power required by the base unit from the amount of power supplied by the base unit. Be sure to subtract 5 VDC and 24 VDC amounts.

Power required by option modules

Next, subtract the amount of power required by the option modules you are planning to use. Again, remember to subtract both 5 VDC and 24 VDC.

If your power budget analysis shows surplus power available, you should have a workable configuration.

DL06 Power Supplied by Base Units		
Part Number	5 VDC (mA)	24 VDC (mA)
D0-06xx	1500mA	300mA
	2000mA	200mA
D0-06xx-D	1500mA	none

DL06 Base Unit Power Required		
Part Number	5 VDC (mA)	24 VDC (mA)
D0-06AA	800mA	none
D0-06AR	900mA	none
D0-06DA	800mA	none
D0-06DD1	600mA	280mA*
D0-06DD2	600mA	none
D0-06DR	950mA	none
D0-06DD1-D	600mA	none
D0-06DD2-D	600mA	none
D0-06DR-D	950mA	none

* Only if auxiliary 24VDC power is connected to V+ terminal.

DL06 Power Consumed by Other Devices		
Part Number	5 VDC (mA)	24 VDC (mA)
D0-06LCD	50mA	none
D2-HPP	200mA	none
DV-1000	150mA	none
C-more Micro-Graphic	210mA	none

Power Budgeting Example			
Power Source		5VDC power (mA)	24VDC power (mA)
D0-06DD1 (select row A or B)	A	1500mA	300mA
	B	2000mA	200mA
Current Required		5VDC power (mA)	24VDC power (mA)
D0-06DD1		600mA	280mA*
D0-16ND3		35mA	0
D0-10TD1		150mA	0
D0-08TR		280mA	0
F0-4AD2DA-1		100mA	0
D0-06LCD		50mA	0
Total Used		1215mA	280mA
Remaining	A	285mA	20mA
	B	785mA	note 1

* Auxiliary 24 VDC used to power V+ terminal of D0-06DD1 sinking outputs.

Note 1: If the PLC's auxiliary 24 VDC power source is used to power the sinking outputs, use power choice A, above.

DL05/06 Power Consumed by Option Modules		
Part Number	5 VDC (mA)	24 VDC (mA)
D0-07CDR	130mA	none
D0-08CDD1	100mA	none
D0-08TR	280mA	none
D0-10ND3	35mA	none
D0-10ND3F	35mA	none
D0-10TD1	150mA	none
D0-10TD2	150mA	none
D0-16ND3	35mA	none
D0-16TD1	200mA	none
D0-16TD2	200mA	none
F0-04TRS	250mA	none
F0-08NA-1	5mA	none
F0-04AD-1	50mA	none
F0-04AD-2	75mA	none
F0-08ADH-1	25mA	25mA
F0-08ADH-2	25mA	25mA
F0-04DAH-1	25mA	150mA
F0-08DAH-1	25mA	220mA
F0-04DAH-2	25mA	30mA
F0-08DAH-2	25mA	30mA
F0-2AD2DA-2	50mA	30mA
F0-4AD2DA-1	100mA	40mA
F0-4AD2DA-2	100mA	none
F0-04RTD	70mA	none
F0-04THM	30mA	none
D0-DEVNETS	45mA	none
H0-PSCM	530mA	none
H0-CTRIO2	250mA	none
H0-ECOM100	300mA	none
F0-08SIM	1mA	none
D0-DCM	250 mA	none
F0-CP128	150 mA	none
F0-08SIM	1 mA	none

DL06 LCD Display

The optional D0-06LCD (\$83.00) is a cost effective LCD display panel that is easy to install. This device is available exclusively for the DL06 PLCs.

16 X 2 backlit display

The 16 character x 2 row display mounts directly on the face of the PLC. The LCD is backlit and is accessible using the seven function keys on the front of the display.

Monitor or change data values

You can view V-memory registers, I/O status, PLC mode, or system errors without interrupting the PLC's control function.

Display messages required for alarm or monitoring purposes can be preprogrammed or imported as ASCII data.

Password protection

Two layers of password protection prevent unauthorized changes to clock and calendar setup and V-memory data values. Individuals with password authorization can change clock, calendar, V-memory values, force bits on or off, etc.

One simple ladder instruction is used to set up the display. The LCD configuration instruction is available in *DirectSOFT*, version 4.0 or later.

Note: The D2-HPP handheld programmer does not support DL06 LCD configuration.

The DL06 User Manual (D0-06USER-M) describes more fully the installation and operation of the D0-06LCD. Be sure to consult this manual before installing the DL06 LCD. The manual is available free on our Web site, or it can be purchased separately.

Snap-in installation

The display installs easily into any model DL06 PLC.

Note: Remove power to the PLC before installing or removing the LCD display.

Remove the plastic cover (located between the input and output terminals) by sliding the cover to the left. In its place, slide in the LCD display until it snaps into place.

Display or change individual bits (up to 16 bits per screen) or 32-bit double word values from V-memory.

Buzzer

The piezoelectric buzzer can be configured to provide pushbutton feedback.

Keypad navigation

Seven function keys on the face of the LCD display provide navigation through messages or menu items. Messages fall into two categories:

- Error messages
- User-defined preprogrammed messages

At power-up the default screen is displayed. The default screen can be user-defined.

Seven menu choices allow you to view or change all accessible data values (see next page).

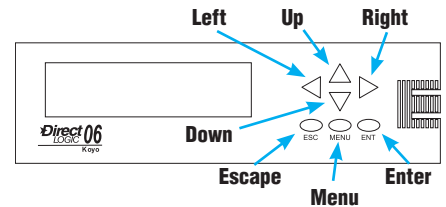

DL06 LCD Display

Menu choices

Pressing the Menu key takes you to the last accessed menu (or the first menu selection, if you haven't previously accessed a menu). Each time you press the Menu key (or if you simply hold the menu key down) the display will step through all menu choices.

There are seven built-in menus. Use the Menu key to locate the menu you need, and press the Enter key to view or change values.

From the default screen or a message screen, press and hold the Menu key. The display will scroll through the following choices:

- M1 : PLC information
- M2 : System configuration
- M3 : Monitor
- M4 : Calendar R/W
- M5 : Password operation
- M6 : Error history read
- M7 : LCD test and set

Make a menu selection by pressing the Enter key. Change data values using the direction arrow keys.

Ladder instruction

The LCD instruction in *DirectSOFT* gives the PLC programmer a convenient way to define screen messages. A literal string can be programmed using the LCD instruction. Embedding variables allows you to customize the messages for an application that involves changing values. The following example shows an embedded date and time on an alarm message:

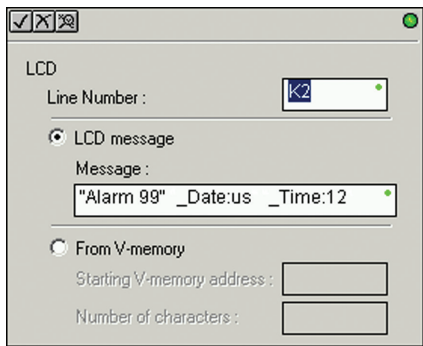

Message with embedded date and time

The top line (16 characters) is designated K1, and the second line is K2. The sample instructions on this page show how a message is developed. A permissive contact turns on the instruction block, which sends the message to the display.

Messages can also be retrieved from V-memory and sent to the display. Select K1 or K2 to indicate which line you want to write to and select "From V-memory" as the source of the string.

Up to 16 characters of ASCII text can be displayed per line. In the example, K16 indicates that 16 bytes (8 words) of ASCII text is retrieved for display.

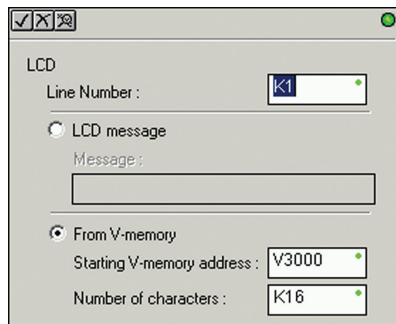

Message from PLC memory

Message programming examples

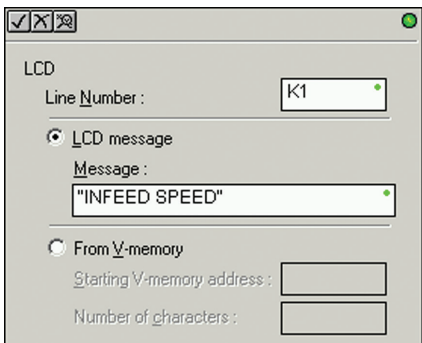

Simple text message

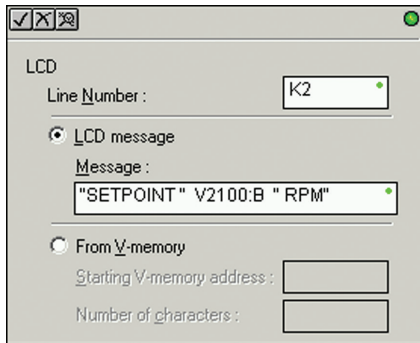

Message with embedded data



Accessories

DL05, DL06 and Option Module Accessories		
Part Number	Description	Price
DO-MC-BAT	Replacement battery for Do-more H2 and T1H series CPU modules, and DO-01MC optional memory cartridge for the DL05 PLCs.	\$3.00
D2-BAT-1	Replacement RAM retentive memory backup battery for the DL06.	\$13.00
FO-IOCON	DL05 or DL06 replacement terminal blocks, 8-position, for the FO-04AD-1, FO-04AD-2, FO-2AD2DA-2, FO-4AD2DA-1, FO-4AD2DA-2 and HO-CTRIO2 option modules (qty. 2).	\$14.00
FO-IOCON-THM	DL05 or DL06 thermocouple option module replacement terminal block, quantity one.	\$14.00
DO-CBL	12ft. (3.66m) RS-232C shielded networking cable without RTS connections for DL05 or DL06 RJ12 networking ports. Enables direct networking of two PLCs.	\$19.00
DO-ACC-1	DL05 accessory pack includes one each of the I/O terminal block, I/O terminal block cover, and option slot cover.	\$13.00
DO-ACC-2	DL06 replacement terminal blocks (qty. 2), terminal block covers (qty. 2), terminal block labels (qty. 2) and short bar (qty. 1).	\$30.00
DO-ACC-3	DL06 replacement option module slot covers (qty. 4), DL06 top covers (qty. 4), LCD slot cover, and lower access panel cover.	\$13.00
DO-ACC-4	DL05 or DL06 discrete I/O option module replacement terminal blocks, includes 13-position (qty. 2) and 10-position (qty. 2).	\$19.00
DO-06ADPTR	DL06 15-pin high density D-sub vertical adapter for DL06 Port 2 serial communications port.	\$27.00
D2-FUSE-1	DL05 or DL06 FO-04TRS replacement fuse	\$12.00
ZL-CMA15	ZIPLink PLC communication adapter for 15-pin port	\$11.00
ZL-CMA15L	ZIPLink PLC communication adapter for 15-pin port with surge protection plus Power, Transmit, and Receive LED indicators	\$33.50

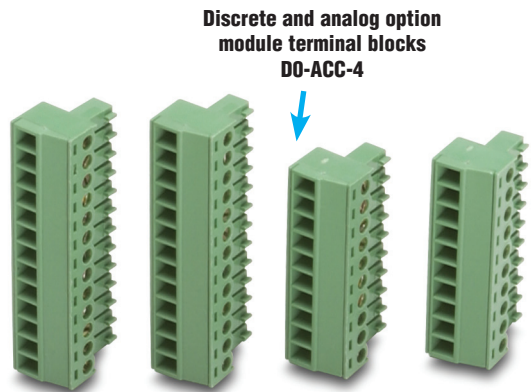

Discrete and analog option module terminal blocks
DO-ACC-4

DL05 option module slot cover, I/O terminal block, and I/O terminal block cover
DO-ACC-1



DL06 replacement option module slot covers, DL06 top covers, LCD slot cover, and lower access panel cover
DO-ACC-3

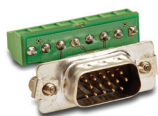
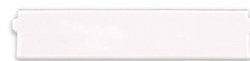

ZL-CMA15



ZL-CMA15L

DL06 replacement terminal blocks, terminal block covers, terminal block labels and short bar
DO-ACC-2

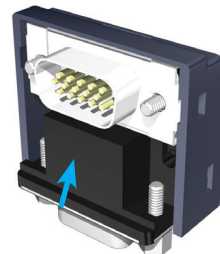
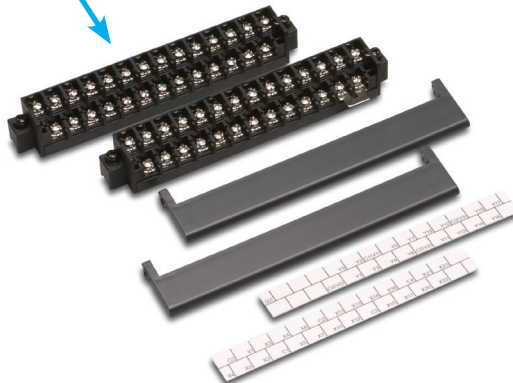

DL06 15-pin high density D-sub port adapter
DO-06ADPTR

See the Wiring Solutions section in this catalog for more information.

DL05 I/O Specifications

D0-05AA \$146.00

Wiring diagram and specifications

D0-05AA Specifications		
AC Power Supply Specifications	Voltage Range	95-240VAC (30VA)
	Number of Input Pts.	8
AC Input Specifications	Number of Commons	2 (isolated)
	Input Voltage Range	90-120VAC
	Frequency Range	47-63Hz
	Input Current	8mA @ 100 VAC at 50 Hz 10mA @ 100 VAC at 60Hz
	On Current/Voltage Level	>6mA/75VAC
	OFF Current/Voltage Level	<2mA/20VAC
	OFF to ON Response	<40ms
	ON to OFF Response	<40ms
	Fuses	None
	AC Output Specifications	Number of Output Points
Number of Commons		2 (isolated)
Output Voltage Range		17-240VAC 47-63Hz
Peak Voltage		264VAC
ON Voltage Drop		1.5 VAC>50mA 4.0VAC<50mA
Maximum Current		0.5A/pt 1.5A/ common
Maximum Leakage Current		4mA at 264VAC
Maximum Inrush Current		10A for 10ms
Minimum Load		10mA
OFF to ON Response		1ms
ON to OFF Response		1ms + 1/2 cycle
Fuses		None (external recommended)

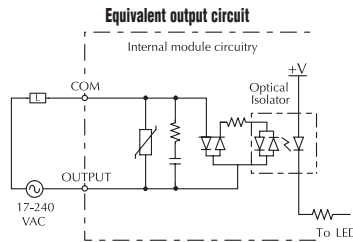
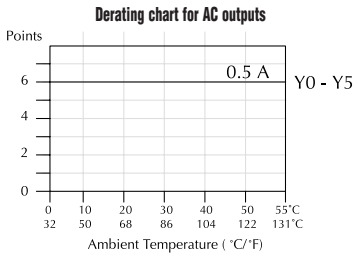
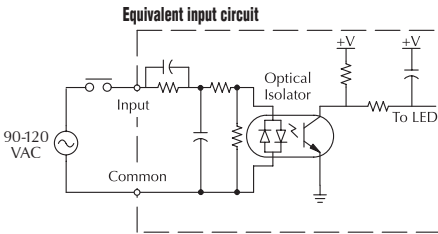
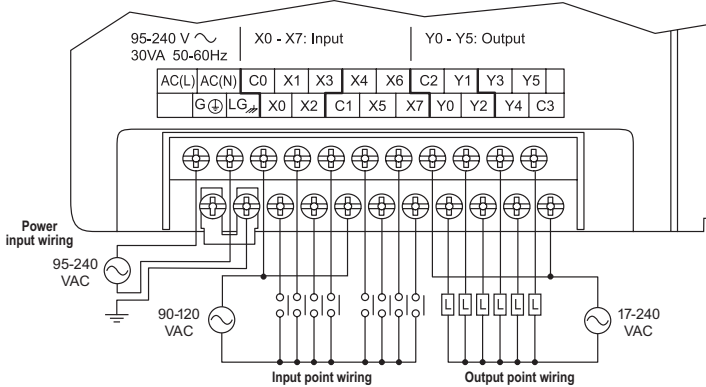

DL05 I/O Specifications

D0-05AD

\$142.00

Wiring diagram and specifications

D0-05AD Specifications			
AC Power Supply Specifications	Voltage Range	95-240VAC (30VA)	
	Number of Input Pts.	8	
	Number of Commons	2 (isolated)	
	Input Voltage Range	90-120VAC	
	Frequency Range	47-63Hz	
	AC Input Specifications	Input Current	8mA @ 100 VAC at 50 Hz 10mA @ 100 VAC at 60Hz
		On Current/Voltage Level	>6mA/75VAC
		OFF Current/Voltage Level	<2mA/20VAC
		OFF to ON Response	<40ms
		ON to OFF Response	<40ms
	Fuses	None	
DC Output Specifications	Number of Output Points	6 (sinking)	
	Number of Commons	1	
	Output Voltage Range	6-27VDC	
	Peak Voltage	50VDC	
	Max. Frequency (Y0, Y1)	7kHz	
	ON Voltage Drop	0.5VDC @ 1A	
	Maximum Current	0.5A/pt (Y0-Y1)* 1.0A pt (Y2-Y5)	
	Maximum Leakage Current	15µA @ 30VDC	
	Maximum Inrush Current	2A for 100ms	
	OFF to ON Response	<10µs	
	ON to OFF Response	<30µs (Y0-Y1) <60µs (Y2-Y5)	
	External DC Power Required	20-28VDC 150mA max	
	Status Indicators	Logic side	
	Fuses	None (external recommended)	

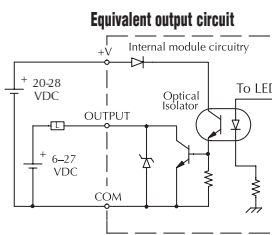
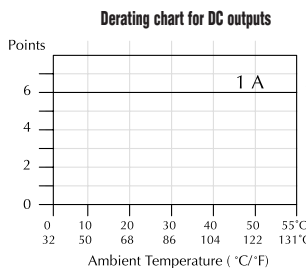
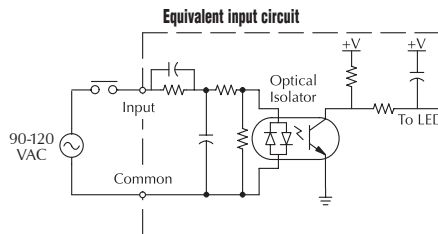
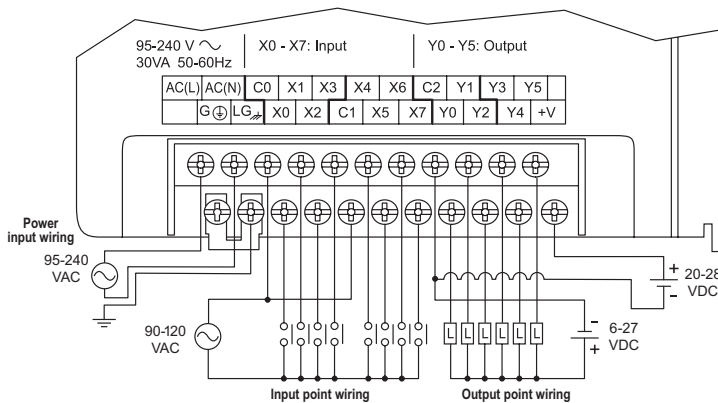

**When output points Y0 and Y1 are not used in pulse mode, the maximum output current is 1.0A*

DL05 I/O Specifications

D0-05AR

\$142.00

Wiring diagram and specifications

D0-05AR Specifications			
AC Power Supply Specifications	Voltage Range	95-240VAC (30VA)	
	Number of Input Pts.	8	
	Number of Commons	2 (isolated)	
	Input Voltage Range	90-120VAC	
	Frequency Range	47-63Hz	
	Input Current	8mA @ 100 VAC at 50 Hz 10mA @ 100 VAC at 60Hz	
	AC Input Specifications	On Current/Voltage Level	>6mA/75VAC
		OFF Current/Voltage Level	<2mA/20VAC
		OFF to ON Response	<40ms
		ON to OFF Response	<40ms
Fuses		None	
Relay Output Specifications		Number of Output Points	6
		Number of Commons	2 (isolated)
	Output Voltage Range	6-240VAC, 47-63Hz 6-27VDC	
	Maximum Voltage	264VAC, 30VDC	
	Maximum Current	2A/point 6A/common	
	Maximum Leakage Current	0.1mA @ 246VAC	
	Smallest Recommended Load	5mA @ 5VDC	
	OFF to ON Response	<15ms	
	ON to OFF Response	<10ms	
	Status Indicators	Logic side	
Fuses	None (external recommended)		

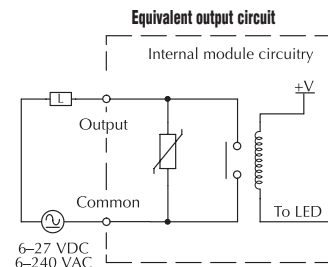
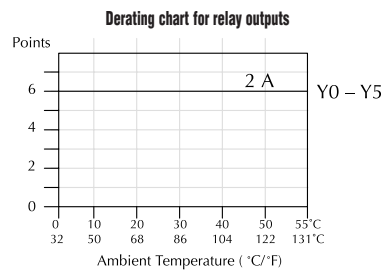
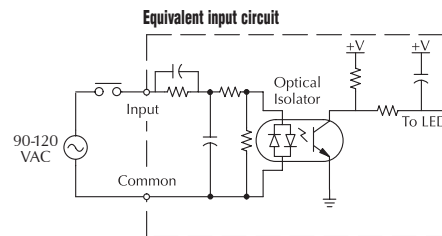
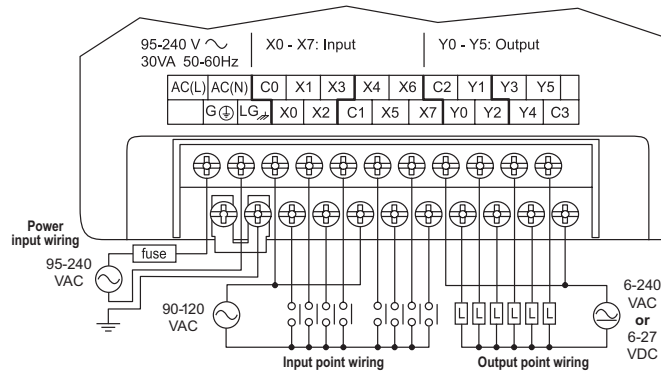

Typical Relay Life (Operations) at Room Temperature		
Voltage and Type of Load	Load Current	
	1A	2A
24 VDC Resistive	600K	270K
24 VDC Solenoid	150K	60K
110 VAC Resistive	900K	350K
110 VAC Solenoid	350K	150K
220 VAC Resistive	600K	250K
220 VAC Solenoid	200K	100K

DL05 I/O Specifications

D0-05DA

\$142.00

Wiring diagram and specifications

D0-05DA Specifications		
AC Power Supply Specifications	Voltage Range	95-240VAC (30VA)
	Number of Input Pts.	8 (sink/source)
	Number of Commons	2 (isolated)
	Input Voltage Range	12-24VDC
	Input Impedance	(X0-X2) 1.8K @ 12-24VDC (X3-X7) 2.8K @ 12-24VDC
	Frequency Range	47-63Hz
	Input Current	8mA @ 100VAC at 50Hz 10mA @ 100VAC at 60Hz
	On Current/Voltage Level	>5mA/10VDC
	OFF Current/Voltage Level	<0.5mA/<2VDC
	Response Time	X0-X2 <8ms X3-X7 <100µs
	OFF to ON Response	<100µs <8ms
	ON to OFF Response	<100µs <8ms
	Fuses	None
DC Input Specifications	Number of Output Points	6
	Number of Commons	2 (isolated)
	Output Voltage Range	17-240VAC 47-63Hz
	Peak Voltage	264VAC
	ON Voltage Drop	1.5VAC >50mA 4.0VAC <50mA
	Maximum Current	0.5A / point
	Maximum Leakage Current	4mA @ 264VAC
	Maximum Inrush Current	10A for 10ms
	Minimum Load	10mA
	OFF to ON Response	1ms
	ON to OFF Response	1ms + 1/2 cycle
	Fuses	None (external recommended)

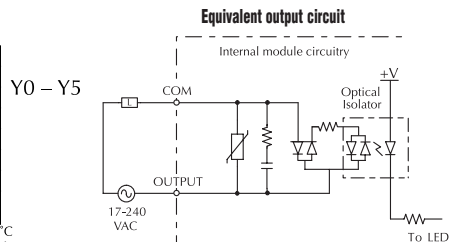
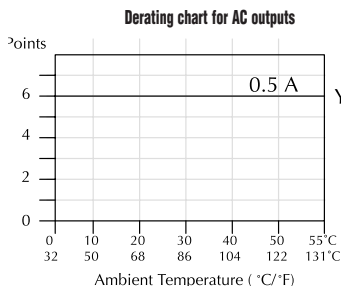
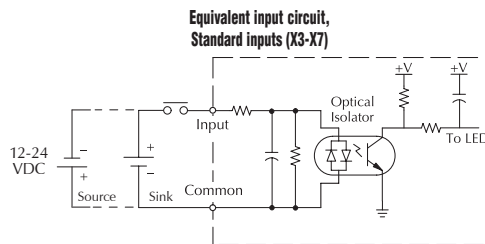
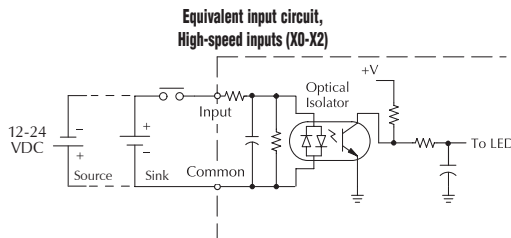
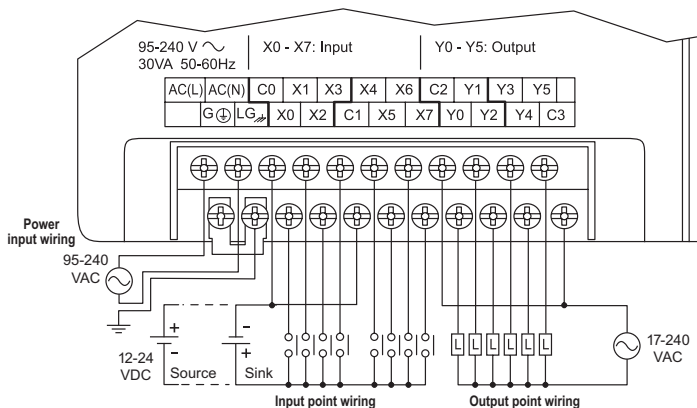

DL05 I/O Specifications

D0-05DD

\$125.00

Wiring diagram and specifications

D0-05DD Specifications		
AC Power Supply Specifications	Voltage Range	95-240VAC (30VA)
	Number of Input Pts.	8 (sink/source)
	Number of Commons	2 (isolated)
	Input Voltage Range	12-24VDC
	Input Impedance	(X0-X2) 1.8K @ 12-24VDC (X3-X7) 2.8K @ 12-24VDC
	On Current/Voltage Level	>5mA/10VDC
	OFF Current/Voltage Level	<0.5mA/<2VDC
	Response Time	X0-X2 X3-X7
	OFF to ON Response	<100µs <8ms
	ON to OFF Response	<100µs <8ms
DC Input Specifications	Fuses	None
	Number of Output Points	6 (sinking)
	Number of Commons	1
	Output Voltage Range	6-27VDC
	Peak Voltage	50VDC
	Max. Frequency (Y0, Y1)	7kHz
	ON Voltage Drop	0.5VDC @ 1A
	Maximum Current	0.5A / point (Y0-Y1)* 1.0A / point (Y2-Y5)
	Maximum Leakage Current	15µA @ 30VDC
	Maximum Inrush Current	2A for 100ms/10A for 10ms
	OFF to ON Response	<10µs
	ON to OFF Response	<30µs (Y0-Y1) <60µs (Y2-Y5)
	External DC Power Required	20-28VDC 150mA max.
	Status Indicators	Logic side
	Fuses	None (external recommended)

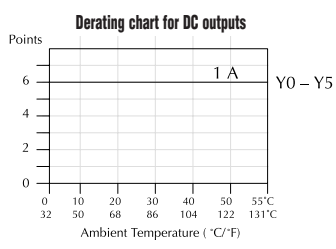
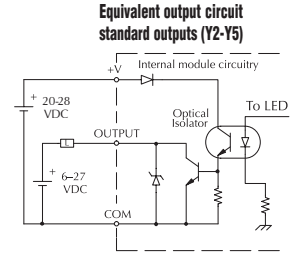
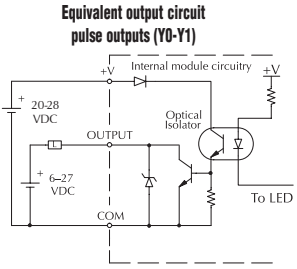
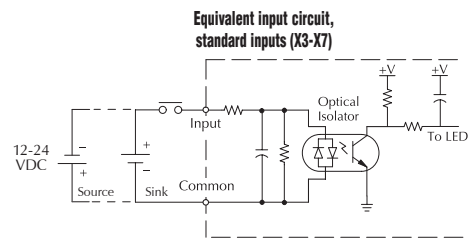
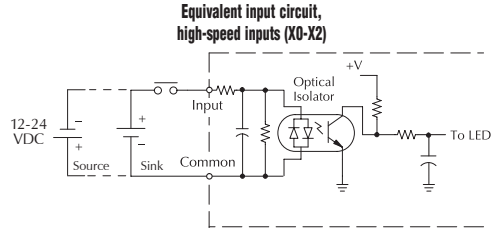
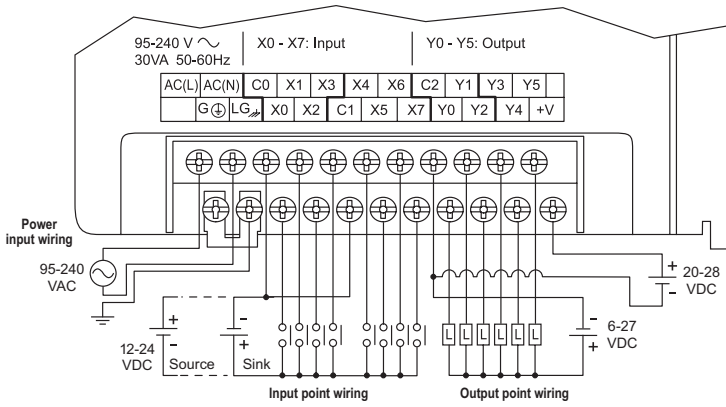

DL05 I/O Specifications

D0-05DR

\$125.00

Wiring diagram and specifications

D0-05DR Specifications		
AC Power Supply Specifications	Voltage Range	95-240VAC (30VA)
	Number of Input Pts.	8 (sink/source)
	Number of Commons	2 (isolated)
	Input Voltage Range	12-24VDC
	Input Impedance	(X0-X2) 1.8K @ 12-24VDC (X3-X7) 2.8K @ 12-24VDC
	On Current/Voltage Level	>5mA/10VDC
	OFF Current/Voltage Level	<0.5mA/<2VDC
	Response Time	X0-X2 X3-X7
	OFF to ON Response	<100µs <8ms
	ON to OFF Response	<100µs <8ms
DC Input Specifications	Fuses	None
	Number of Output Points	6
	Number of Commons	2 (isolated)
	Output Voltage Range	6-240VAC, 47-63Hz 6-27VDC
	Maximum Voltage	264VAC, 30VDC
	Maximum Current	2A/point 6A/common
	Maximum Leakage Current	0.1mA @ 246VAC
	Smallest Recommended Load	5mA @ 5VDC
	OFF to ON Response	<15ms
	ON to OFF Response	<10ms
	Status Indicators	Logic side
	Fuses	None (external recommended)

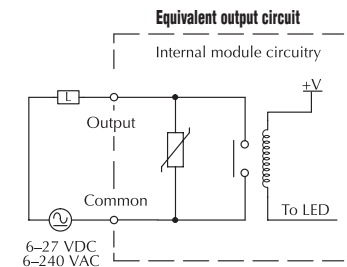
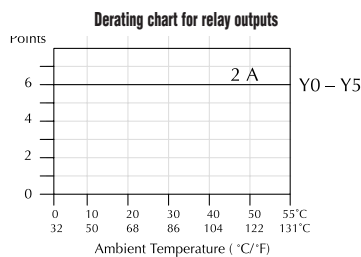
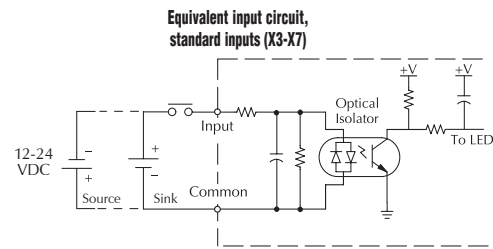
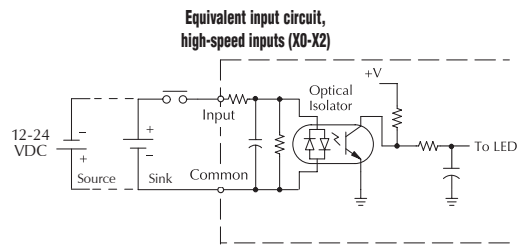
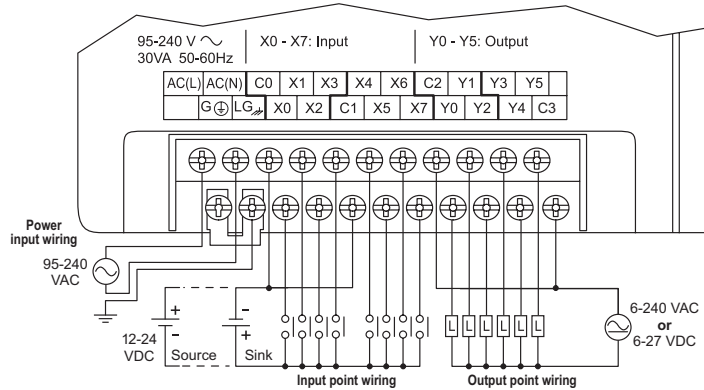

Typical Relay Life (Operations) at Room Temperature		
Voltage and Type of Load	Load Current	
	1A	2A
24 VDC Resistive	600K	270K
24 VDC Solenoid	150K	60K
110 VAC Resistive	900K	350K
110 VAC Solenoid	350K	150K
220 VAC Resistive	600K	250K
220 VAC Solenoid	200K	100K

DL05 I/O Specifications

D0-05DD-D \$136.00

Wiring diagram and specifications

D0-05DD-D Specifications		
DC Power Supply Specifications	Voltage Range	12-24VDC 20W max.
	Number of Input Pts.	8 (sink/source)
	Number of Commons	2 (isolated)
	Input Voltage Range	12-24VDC
	Input Impedance	(X0-X2) 1.8K @ 12-24VDC (X3-X7) 2.8K @ 12-24VDC
	On Current/Voltage Level	>5mA/10VDC
	OFF Current/Voltage Level	<0.5mA/<2VDC
	Response Time	X0-X2 X3-X7
	OFF to ON Response	<100µs <8ms
	ON to OFF Response	<100µs <8ms
DC Input Specifications	Fuses	None
	Number of Output Pts.	6 (sinking)
	Number of Commons	1
	Output Voltage Range	6-27VDC
	Peak Voltage	50VDC
	Max. Frequency (Y0, Y1)	7kHz
	ON Voltage Drop	0.5VDC @ 1A
	Maximum Current	0.5A / point (Y0-Y1)* 1.0A / point (Y2-Y5)
	Maximum Leakage Current	15µ @ 30VDC
	Maximum Inrush Current	2A for 100ms 10A for 10ms
	OFF to ON Response	<10µ
	ON to OFF Response	<30µs (Y0-Y1) <60µs (Y2-Y5)
	External DC Power Required	20-28VDC 150mA max.
	Status Indicators	Logic side
	Fuses	None (external recommended)

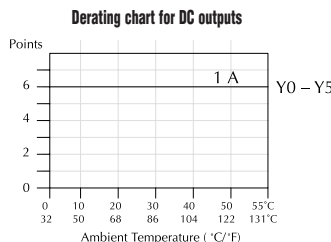
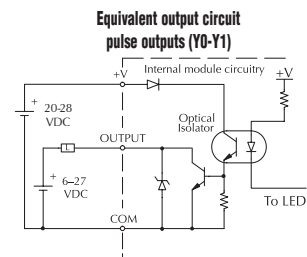
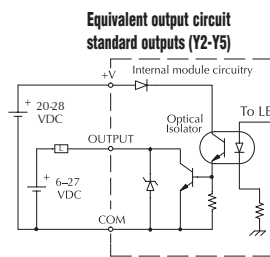
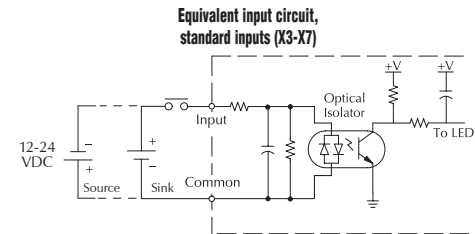
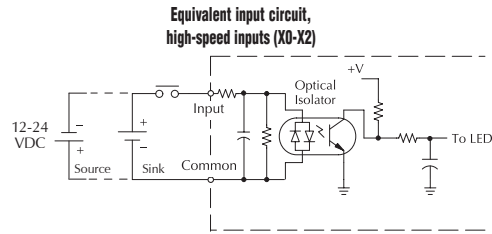
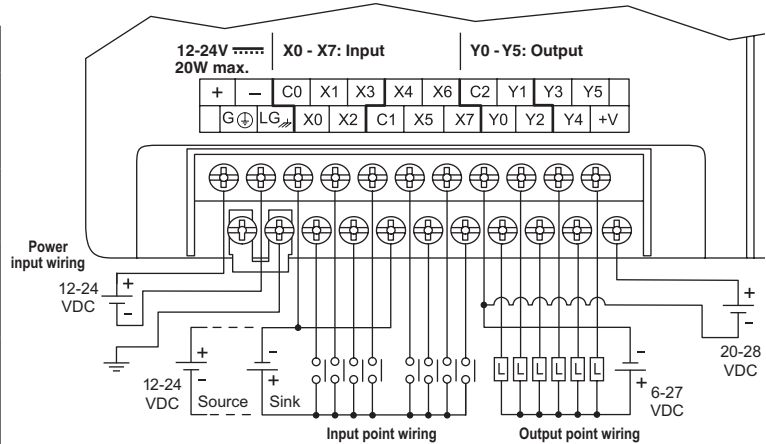

*When output points Y0 and Y1 are not used in pulse mode, the maximum output current is 1.0A

DL05 I/O Specifications

D0-05DR-D \$136.00

Wiring diagram and specifications

D0-05DR-D Specifications		
DC Power Supply Specifications	Voltage Range	12-24VDC 20W max.
	Number of Input Pts.	8 (sink/source)
	Number of Commons	2 (isolated)
	Input Voltage Range	12-24VDC
	Input Impedance	(X0-X2) 1.8K @ 12-24VDC (X3-X7) 2.8K @ 12-24VDC
	On Current/Voltage Level	>5mA/10VDC
	OFF Current/Voltage Level	<0.5mA/<2VDC
	Response Time	X0-X2 X3-X7
	OFF to ON Response	<100µs <8ms
	ON to OFF Response	<100µs <8ms
DC Input Specifications	Fuses	None
	Number of Output Points	6
	Number of Commons	2 (isolated)
	Output Voltage Range	6-240VAC, 47-63Hz 6-27VDC
	Maximum Voltage	264VAC,30VDC
	Maximum Output Current	2A/point 6A/common
	Maximum Leakage Current	0.1mA @ 246VAC
	Smallest Recommended Load	5mA @ 5VDC
	OFF to ON Response	<15ms
	ON to OFF Response	<10ms
	Status Indicators	Logic side
	Fuses	None (external recommended)

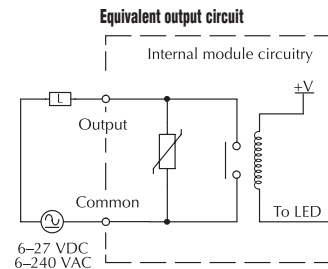
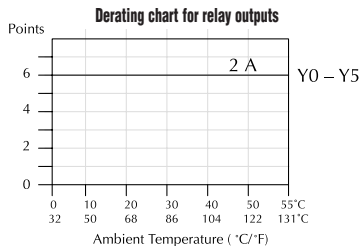
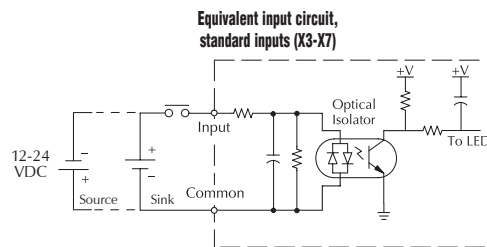
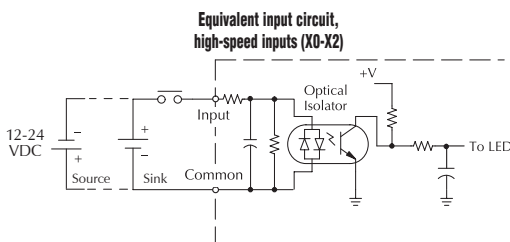
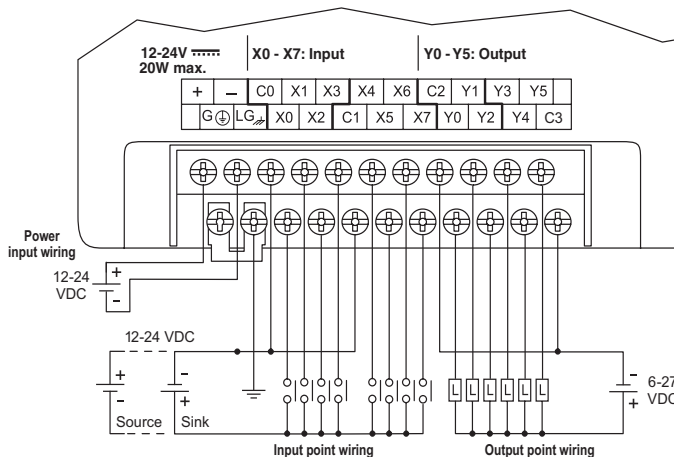

Typical Relay Life (Operations) at Room Temperature		
Voltage and Type of Load	Load Current	
	1A	2A
24 VDC Resistive	600K	270K
24 VDC Solenoid	150K	60K
110 VAC Resistive	900K	350K
110 VAC Solenoid	350K	150K
220 VAC Resistive	600K	250K
220 VAC Solenoid	200K	100K

DL06 I/O Specifications

D0-06AA \$314.00

Wiring diagram and specifications

D0-06AA Specifications		
AC Power Supply Specifications	Voltage Range	95-240VAC (40VA)
AC Input Specifications	Number of Input Pts.	20
	Number of Commons	5 (isolated)
	Input Voltage Range	90-120VAC
	Frequency Range	47-63Hz
	Input Current	8mA @ 100 VAC at 50 Hz 10mA @ 100 VAC at 60Hz
	On Current/Voltage Level	>6mA/75VAC
	OFF Current/Voltage Level	<2mA/20VAC
	OFF to ON Response	<40ms
AC Output Specifications	Number of Output Points	16
	Number of Commons	4 (isolated)
	Output Voltage Range	17-240VAC 47-63Hz
	Peak Voltage	264VAC
	ON Voltage Drop	1.5 VAC>50mA 4.0VAC<50mA
	Maximum Current	0.5A/pt 2.0A/common
	Maximum Leakage Current	4mA at 264VAC
	Maximum Inrush Current	10A for 10ms
	Minimum Load	10mA
	OFF to ON Response	<1ms
	ON to OFF Response	<1ms + 1/2 cycle
	Fuses	None (external recommended)

Note: Refer to Power Budgeting for Auxiliary 24VDC current available.

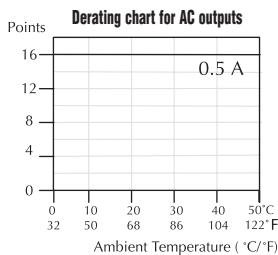
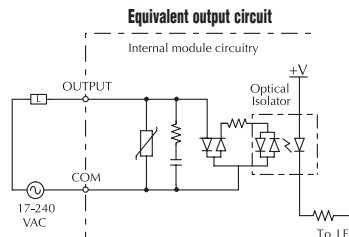
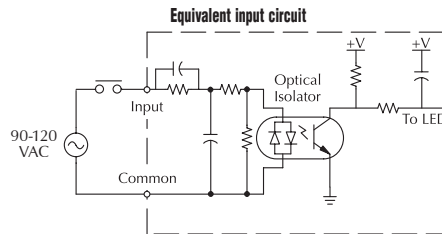
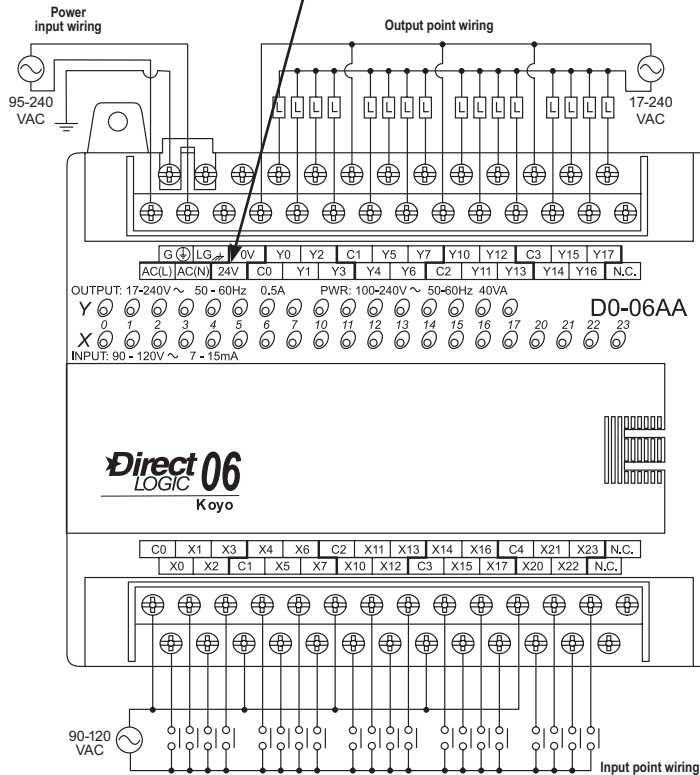

Company Information

Control Systems Overview

CLICK PLC

Do-More PLCs Overview

Do-More H2 PLC

Do-More T1H PLC

Direct LOGIC PLCs Overview

Direct LOGIC DL05/06

Direct LOGIC DL105

Direct LOGIC DL205

Direct LOGIC DL305

Direct LOGIC DL405

Productivity Controller Overview

Productivity 3000

Universal Field I/O

Software

C-More HMI

C-More Micro HMI

ViewMarq Industrial Marquees

Other HMI

Communications

Appendix Book 1

Terms and Conditions

DL06 I/O Specifications

D0-06AR

\$293.00

Wiring diagram and specifications

D0-06AR Specifications		
AC Power Supply Specifications	Voltage Range	95-240VAC (40VA)
	Number of Input Pts.	20
	Number of Commons	5 (isolated)
	Input Voltage Range	90-120VAC
	Frequency Range	47-63Hz
	Input Current	8mA @ 100 VAC at 50 Hz 10mA @ 100 VAC at 60Hz
	On Current/ Voltage Level	>6mA/75VAC
	OFF Current/ Voltage Level	<2mA/20VAC
	OFF to ON Response	<40ms
	ON to OFF Response	<40ms
Fuses	None	
AC Input Specifications	Number of Output Points	16
	Number of Commons	4 (isolated)
	Output Voltage Range	6-240VAC, 47-63Hz 6-27VDC
	Maximum Voltage	264VAC,30VDC
	Maximum Current	2A/point 6A/common
	Maximum Leakage Current	0.1mA @ 246VAC
	Smallest Recommended Load	5mA @ 5VDC
	OFF to ON Response	<15ms
	ON to OFF Response	<10ms
	Status Indicators	Logic side
Fuses	None (external recommended)	

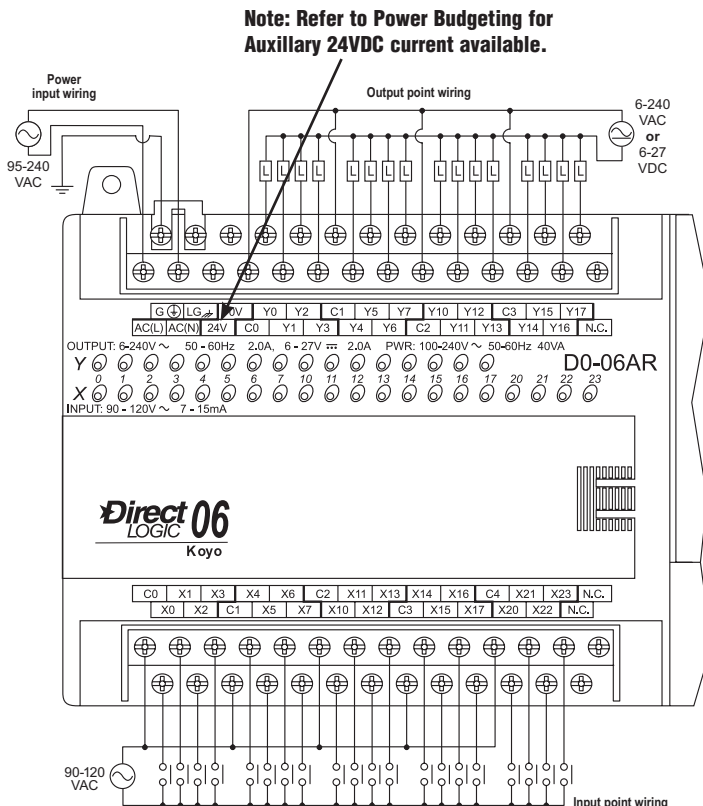

Note: Refer to Power Budgeting for Auxillary 24VDC current available.

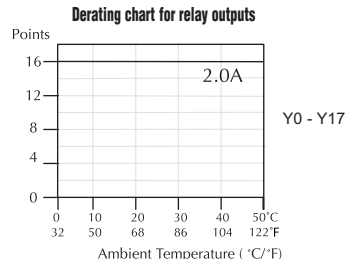
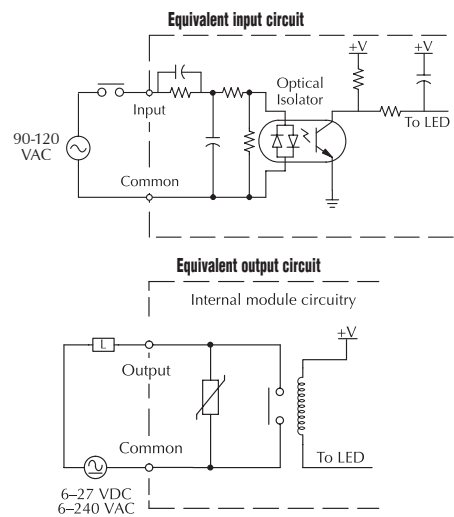

Typical Relay Life (Operations) at Room Temperature		
Voltage and Type of Load	Load Current	
	At 1A	At 2A
24 VDC Resistive	500K	250K
24 VDC Inductive	100K	50K
110 VAC Resistive	500K	250K
110 VAC Inductive	200K	100K
220 VAC Resistive	350K	200K
220 VAC Inductive	100K	50K

DL06 I/O Specifications

D0-06DA

\$293.00

Wiring diagram and specifications

D0-06DA Specifications			
AC Power Supply Specifications	Voltage Range	100-240VAC (40VA)	
	Number of Input Pts.	20 (sink/source)	
	Number of Commons	5 (isolated)	
	Input Voltage Range	10.8-26.4VDC	
	Input Impedance	(X0-X3) 1.8K @ 12-24VDC	
		(X4-X23) 2.8K @ 12-24VDC	
	On Current/Voltage Level	>5mA/10VDC	
	OFF Current/Voltage Level	<0.5mA/-2VDC	
	Response Time	X0-X3 X4-X23	
	OFF to ON Response	<70µs 2-8ms	
ON to OFF Response	<70µs 2-8ms		
Fuses	None		
DC Input Specifications	Number of Output Points	16	
	Number of Commons	4 (isolated)	
	Operating Voltage Range	17-240VAC 47-63Hz	
	Peak Voltage	264VAC	
	ON Voltage Drop	1.5VAC >50mA 4.0VAC <50mA	
	Maximum Current	0.5A / point; 1.5A / common	
	Maximum Leakage Current	4mA @ 264VAC, 60 Hz	
	Maximum Inrush Current	10A for 10ms	
	Minimum Load	10mA	
	OFF to ON Response	1ms	
	ON to OFF Response	1ms + 1/2 cycle	
	Fuses	None (external recommended)	
	AC Output Specifications	Number of Output Points	16
Number of Commons		4 (isolated)	
Operating Voltage Range		17-240VAC 47-63Hz	
Peak Voltage		264VAC	
ON Voltage Drop		1.5VAC >50mA 4.0VAC <50mA	
Maximum Current		0.5A / point; 1.5A / common	
Maximum Leakage Current		4mA @ 264VAC, 60 Hz	
Maximum Inrush Current		10A for 10ms	
Minimum Load		10mA	
OFF to ON Response		1ms	
ON to OFF Response		1ms + 1/2 cycle	
Fuses		None (external recommended)	

Note: Refer to Power Budgeting for Auxiliary 24VDC current available.

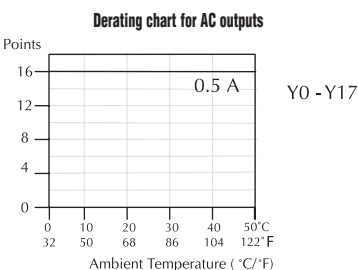
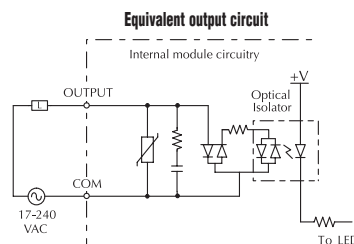
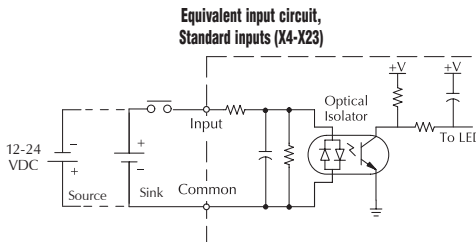
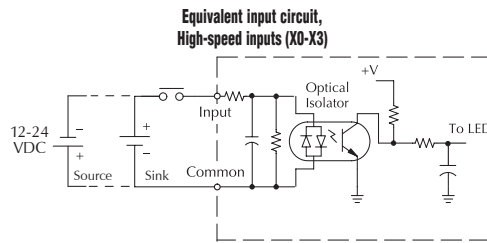
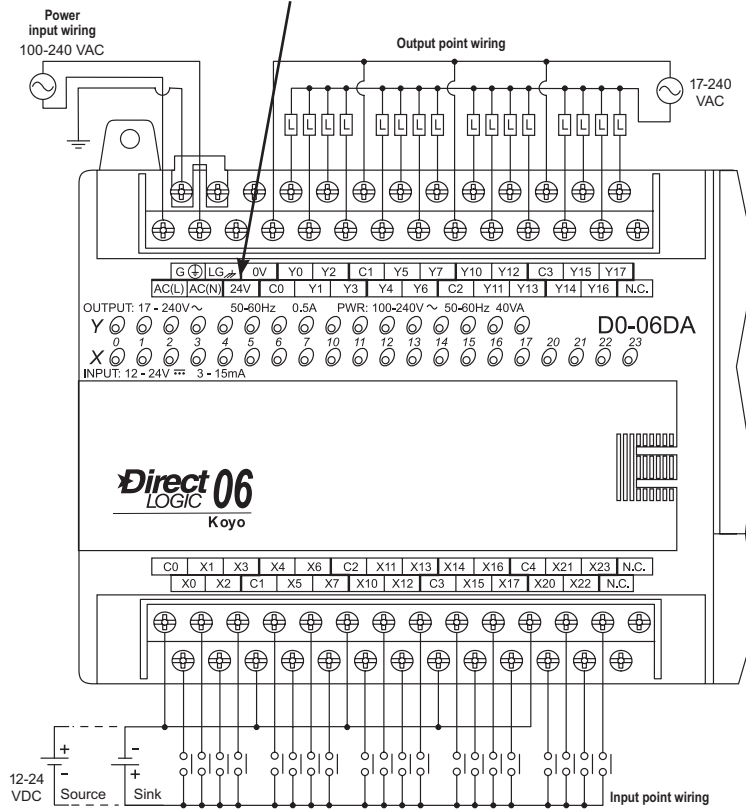

DL06 I/O Specifications

D0-06DD1 \$251.00

Wiring diagram and specifications

D0-06DD1 Specifications		
AC Power Supply Specifications	Voltage Range	95-240VAC (40VA)
	Number of Input Pts.	20 (sink/source)
DC Input Specifications	Number of Commons	5 (isolated)
	Input Voltage Range	12-24VDC
	Input Impedance	(X0-X3) 1.8K @ 12-24VDC (X4-X23) 2.8K @ 12-24VDC
	On Current/Voltage Level	>5mA/10VDC
	OFF Current/Voltage Level	<0.5mA/<2VDC
	Response Time	X0-X3 X4-X23
	OFF to ON Response	<100µs <8ms
	ON to OFF Response	<100µs <8ms
	Fuses	None
	DC Output Specifications	Number of Output Points
Number of Commons		4 isolated
Output Voltage Range		6-27VDC
Peak Voltage		50VDC
Max. Frequency (Y0, Y1)		7kHz
ON Voltage Drop		0.3VDC @ 1A
Maximum Current		0.5A / pt (Y0-Y1)* 1.0A pt (Y2-Y17)**
Maximum Leakage Current		15µA @ 30VDC
Maximum Inrush Current		2A for 100ms
OFF to ON Response		<10µs
ON to OFF Response		<20µs (Y0-Y1) <60µs (Y2-Y17)
External DC Power Required		20-28VDC 150mA max. (Y0-Y1) 280 mA max. (Y2-Y17)
Status Indicators		Logic side
Fuses		None (external recommended)

* When Y0-Y1 are not used for pulse outputs, maximum current output is 1.0A**.

** These outputs must be derated to 0.6A for EN61131-2 compliance.

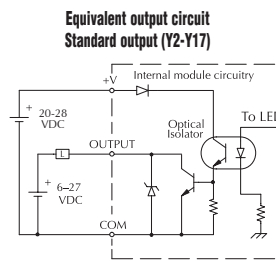
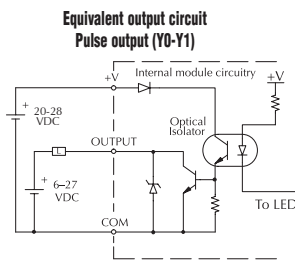
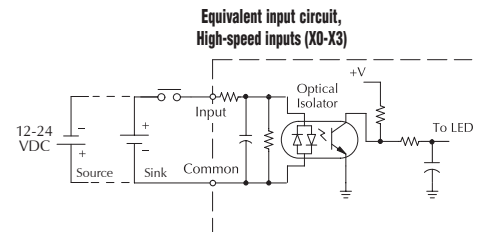
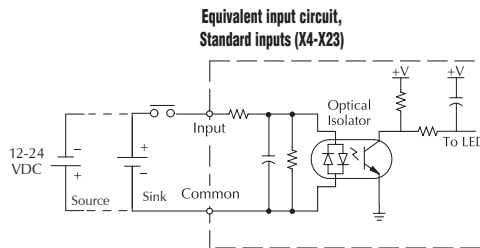
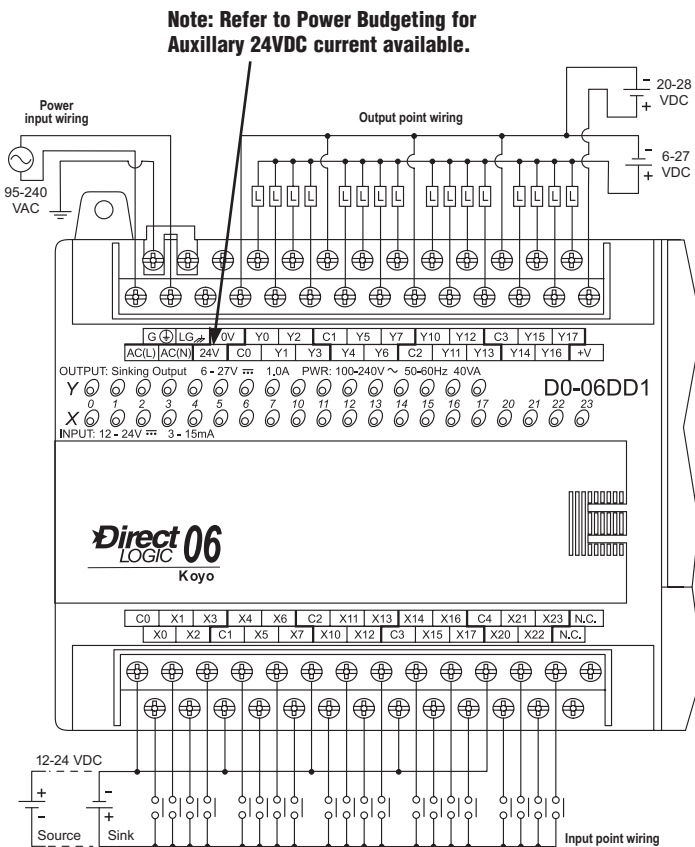
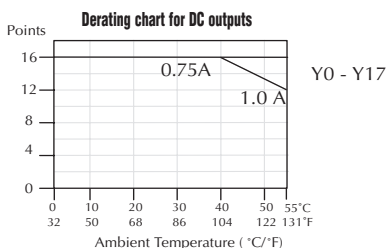

DL06 I/O Specifications

D0-06DD2 \$251.00

Wiring diagram and specifications

D0-06DD2 Specifications			
AC Power Supply Specifications	Voltage Range	95-240VAC (40VA)	
	Number of Input Pts.	20 (sink/source)	
	Number of Commons	5 (isolated)	
	Input Voltage Range	12-24VDC	
	Input Impedance	(X0-X3) 1.8K @ 12-24VDC	
		(X4-X23) 2.8K @ 12-24VDC	
	On Current/Voltage Level	5mA/ >10VDC	
	OFF Current/Voltage Level	0.5mA/ <2VDC	
	Response Time	X0-X3	X4-X23
			2-8ms Typ. 4ms
OFF to ON Response		<70µs	
		2-8ms Typ. 4ms	
ON to OFF Response		<70µs	
		2-8ms Typ. 4ms	
Fuses	None		
DC Input Specifications	Number of Output Points	16 (sourcing)	
	Number of Commons	4 isolated	
	Output Voltage Range	12-24VDC	
	Peak Voltage	30VDC	
	Max. Frequency (Y0, Y1)	10kHz	
	ON Voltage Drop	0.5VDC @ 1A (Y0-Y1)	
		1.2VDC @ 1A (Y2-Y17)	
	Maximum Current	0.5A / pt (Y0-Y1)* 1.0A pt (Y2-Y17)	
	Maximum Leakage Current	15µA @ 30VDC	
	Maximum Inrush Current	2A for 100ms	
	OFF to ON Response	<10µs	
	ON to OFF Response	<20µs (Y0-Y1) <0.5ms (Y2-Y17)	
	External DC Power Required	N/A	
	Status Indicators	Logic side	
	Fuses	None (external recommended)	
DC Output Specifications	Number of Output Points	16 (sourcing)	
	Number of Commons	4 isolated	
	Output Voltage Range	12-24VDC	
	Peak Voltage	30VDC	
	Max. Frequency (Y0, Y1)	10kHz	
	ON Voltage Drop	0.5VDC @ 1A (Y0-Y1)	
		1.2VDC @ 1A (Y2-Y17)	
	Maximum Current	0.5A / pt (Y0-Y1)* 1.0A pt (Y2-Y17)	
	Maximum Leakage Current	15µA @ 30VDC	
	Maximum Inrush Current	2A for 100ms	
	OFF to ON Response	<10µs	
	ON to OFF Response	<20µs (Y0-Y1) <0.5ms (Y2-Y17)	
	External DC Power Required	N/A	
	Status Indicators	Logic side	
	Fuses	None (external recommended)	

*When Y0-Y1 are not used for pulse outputs, maximum current output is 1.0A.

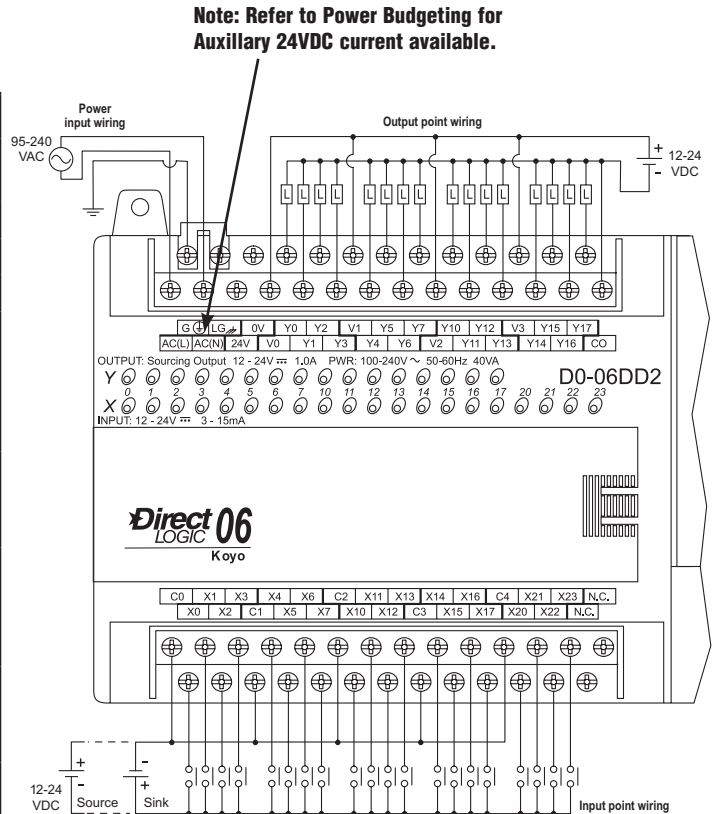
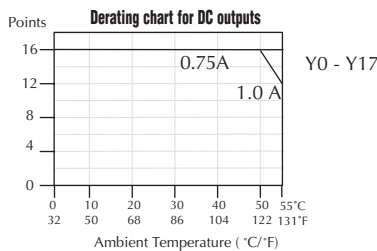

Equivalent input circuit, Standard inputs (X4-X23)

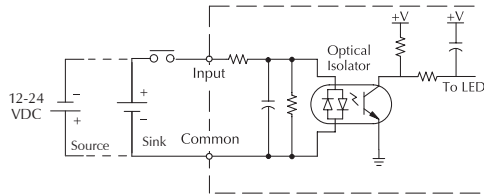

Equivalent input circuit, High-speed inputs (X0-X3)

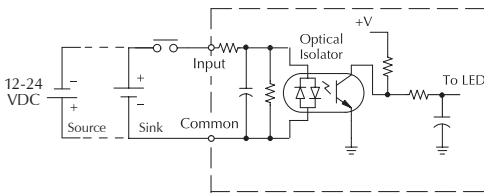

Equivalent output circuit Pulse output (Y0-Y1)

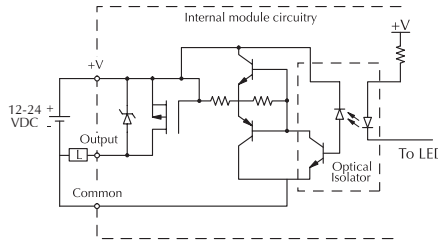

Equivalent output circuit Standard output (Y2-Y17)

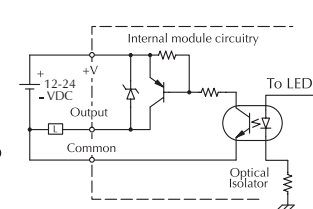

DL06 I/O Specifications

D0-06DR **\$272.00**

Wiring diagram and specifications

D0-06DR Specifications		
AC Power Supply Specifications	Voltage Range	100-240VAC (40VA)
	Number of Input Pts.	20 (sink/source)
DC Input Specifications	Number of Commons	5 (isolated)
	Input Voltage Range	12-24VDC
	Input Impedance	(X0-X3) 1.8K @ 12-24VDC (X4-X23) 2.8K @ 12-24VDC
	On Current/Voltage Level	>5mA/10VDC
	OFF Current/Voltage Level	<0.5mA/<2VDC
	Response Time	X0-X3 X4-X23
	OFF to ON Response	<100µs <8ms
	ON to OFF Response	<100µs <8ms
	Fuses	None
	Relay Output Specifications	Number of Output Points
Number of Commons		4 (isolated)
Output Voltage Range		6-240VAC, 47-63Hz 6-27VDC
Maximum Voltage		264VAC, 30VDC
Maximum Current		2A/point 6A/common
Maximum Leakage Current		0.1mA @ 246VAC
Smallest Recommended Load		5mA @ 5VDC
OFF to ON Response		<15ms
ON to OFF Response		<10ms
Status Indicators		Logic side
Fuses	None (external recommended)	

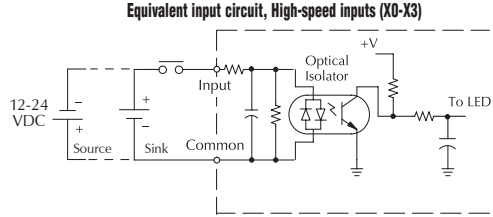
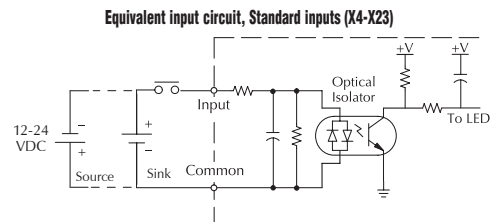
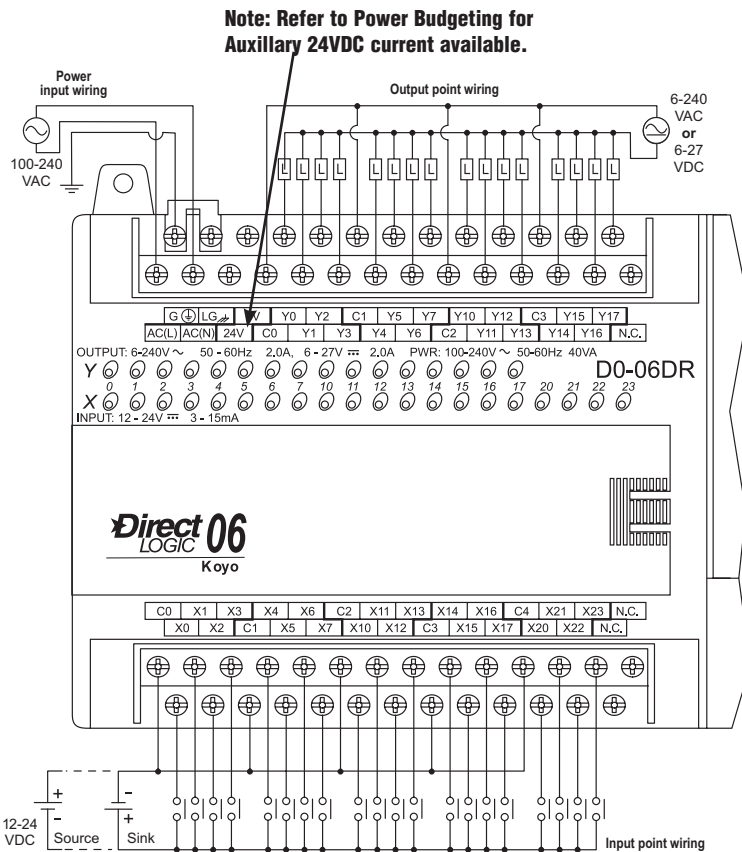

Typical Relay Life (Operations) at Room Temperature

Voltage and Type of Load	Load Current	
	At 1A	At 2A
24 VDC Resistive	500K	250K
24 VDC Inductive	100K	50K
110 VAC Resistive	500K	250K
110 VAC Inductive	200K	100K
220 VAC Resistive	350K	200K
220 VAC Inductive	100K	50K

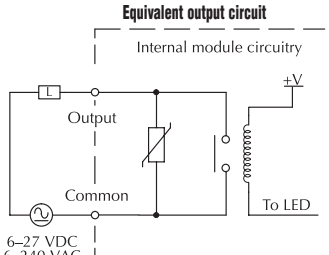
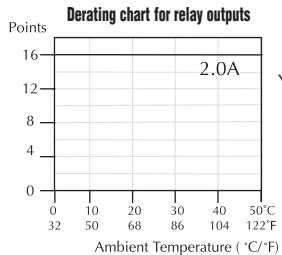

DL06 I/O Specifications

D0-06DD1-D \$251.00

Wiring diagram and specifications

D0-06DD1-D Specifications			
DC Power Supply Specifications	Voltage Range	12-24VDC (20W)	
	Number of Input Pts.	20 (sink/source)	
	Number of Commons	5 (isolated)	
	Input Voltage Range	12-24VDC	
	Input Impedance	(X0-X3) 1.8K @ 12-24VDC	
		(X4-X23) 2.8K @ 12-24VDC	
	On Current/Voltage Level	>5mA/10VDC	
	OFF Current/Voltage Level	<0.5mA/<2VDC	
	Response Time	X0-X3 X4-X23	
	OFF to ON Response	<100µs <8ms	
ON to OFF Response	<100µs <8ms		
Fuses	None		
DC Input Specifications	Number of Output Points	16 (sinking)	
	Number of Commons	4 isolated	
	Output Voltage Range	6-27VDC	
	Peak Voltage	50VDC	
	Max.Frequency (Y0, Y1)	7kHz	
	ON Voltage Drop	0.3VDC @ 1A	
	Maximum Current	0.5A / point (Y0-Y1)*	
		1.0A / point (Y2-Y17)**	
	Maximum Leakage Current	15µA @ 30VDC	
	Maximum Inrush Current	2A for 100ms	
	OFF to ON Response	<10µs	
	ON to OFF Response	<20µs (Y0-Y1) <60µs (Y2-Y17)	
	External DC Power Required	20-28VDC 150mA max.	
	Status Indicators	Logic side	
	Fuses	None (external recommended)	
	DC Output Specifications	Number of Output Points	16 (sinking)
		Number of Commons	4 isolated
Output Voltage Range		6-27VDC	
Peak Voltage		50VDC	
Max.Frequency (Y0, Y1)		7kHz	
ON Voltage Drop		0.3VDC @ 1A	
Maximum Current		0.5A / point (Y0-Y1)*	
		1.0A / point (Y2-Y17)**	
Maximum Leakage Current		15µA @ 30VDC	
Maximum Inrush Current		2A for 100ms	
OFF to ON Response		<10µs	
ON to OFF Response		<20µs (Y0-Y1) <60µs (Y2-Y17)	
External DC Power Required		20-28VDC 150mA max.	
Status Indicators		Logic side	
Fuses		None (external recommended)	

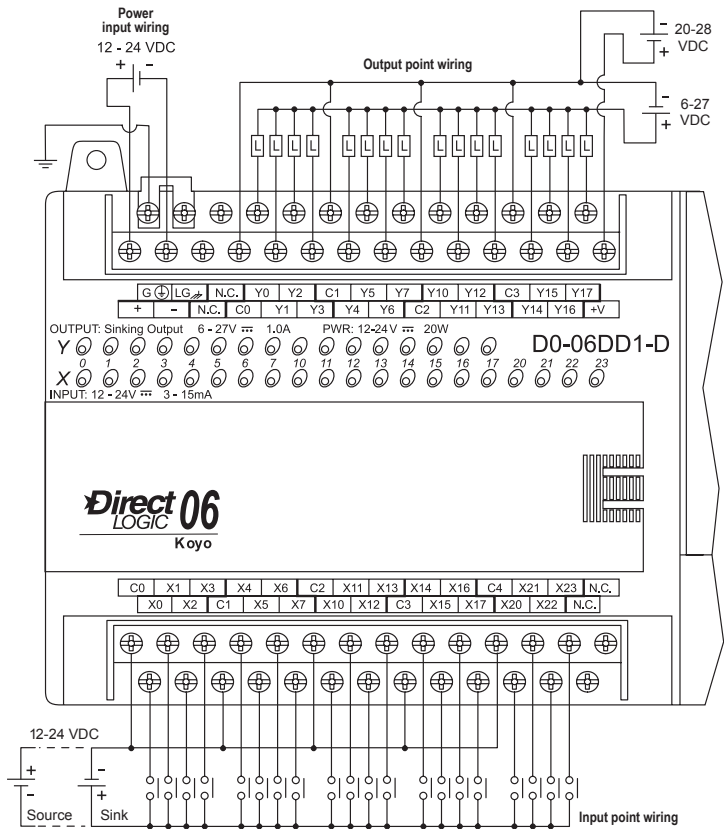

Equivalent input circuit, Standard inputs (X4-X23)

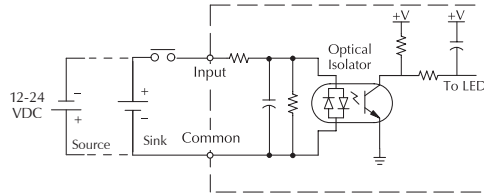

Equivalent input circuit, High-speed inputs (X0-X3)

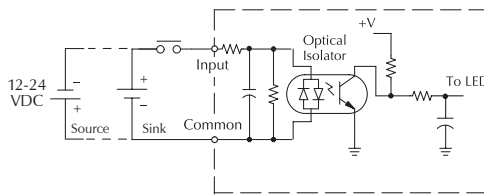

Equivalent output circuit Pulse output (Y0-Y1)

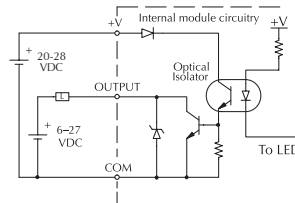

Equivalent output circuit Standard output (Y2-Y17)

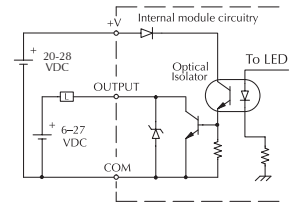

*When Y0-Y1 are not used for pulse outputs, maximum current output is 1.0A**.

** These outputs must be derated to 0.6A for EN61131-2 compliance.

Derating chart for DC outputs

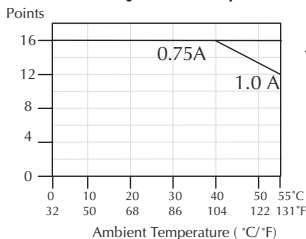

DL06 I/O Specifications

D0-06DD2-D \$251.00

Wiring diagram and specifications

D0-06DD2-D Specifications			
DC Power Supply Specifications	Voltage Range	12-24VDC (20W)	
	Number of Input Pts.	20 (sink/source)	
	Number of Commons	5 (isolated)	
	Input Voltage Range	12-24VDC	
	Input Impedance	(X0-X3)	1.8K @ 12-24VDC
		(X4-X23)	2.8K @ 12-24VDC
	DC Input Specifications	On Current/Voltage Level	5mA/>10VDC
		OFF Current/Voltage Level	0.5mA/<2VDC
		Response Time	X0-X3 X4-X23
OFF to ON Response		<70µS	2-8mS Typ. 4mS
		<70µS	2-8mS Typ. 4mS
ON to OFF Response		<70µS	2-8mS Typ. 4mS
Fuses		None	
DC Output Specifications		Number of Output Points	16 (sourcing)
		Number of Commons	4 isolated
		Output Voltage Range	12-24VDC
	Peak Voltage	30VDC	
	Max. Frequency (Y0, Y1)	10kHz	
	ON Voltage Drop	0.5VDC @ 1A (Y0-Y1)	1.2VDC @ 1A (Y2-Y17)
	Maximum Current	0.5A / point (Y0-Y1)*	1.0A / point (Y2-Y17)
	Maximum Leakage Current	15µA @ 30VDC	
	Maximum Inrush Current	2A for 100ms	
	OFF to ON Response	<10µS	
	ON to OFF Response	<20µS (Y0-Y1) <0.5mS (Y2-Y17)	
	External DC Power Required	N/A	
	Status Indicators	Logic side	
Fuses	None (external recommended)		

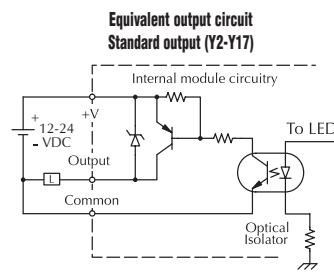
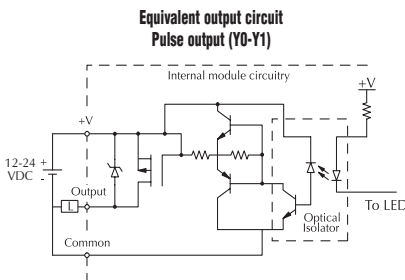
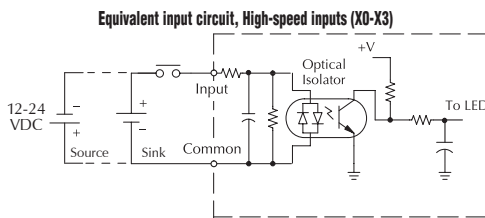
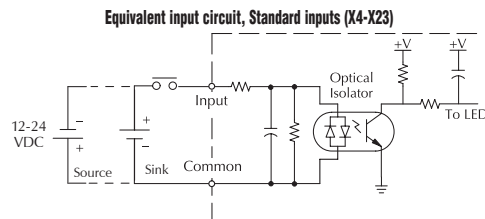
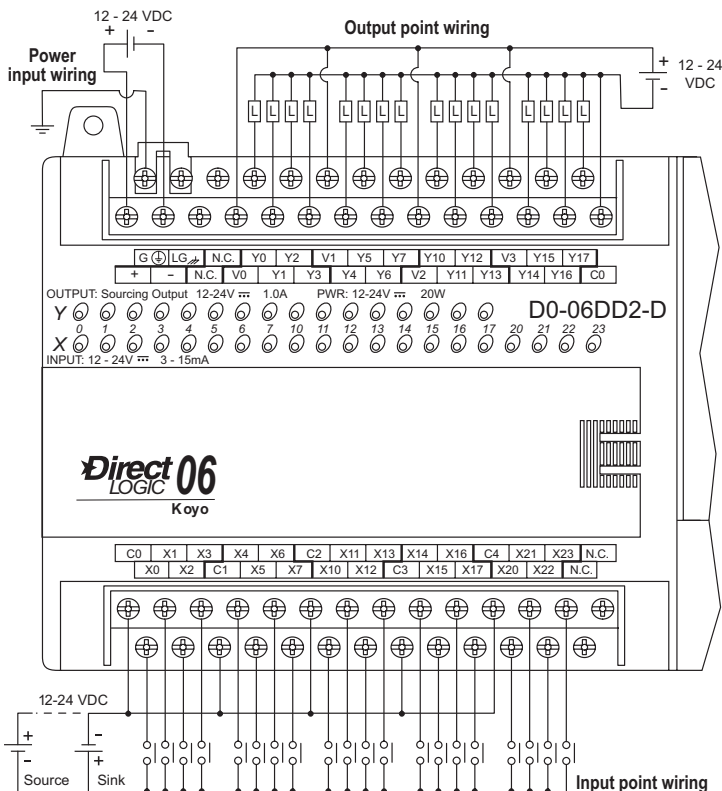

*When Y0-Y1 are not used for pulse outputs, maximum current output is 1.0A.

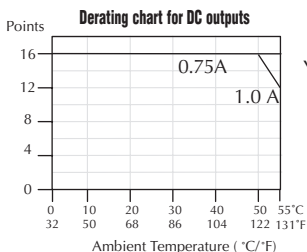

Y0 - Y17

DL06 I/O Specifications

D0-06DR-D **\$272.00**

Wiring diagram and specifications

D0-06DR-D Specifications		
DC Power Supply Specifications	Voltage Range	12-24VDC 20W max.
	Number of Input Pts.	20 (sink/source)
	Number of Commons	5 (isolated)
	Input Voltage Range	12-24VDC
	Input Impedance	(X0-X3) 1.8K @ 12-24VDC (X4-X23) 2.8K @ 12-24VDC
	On Current/Voltage Level	>5mA/10VDC
	OFF Current/Voltage Level	<0.5mA/<2VDC
	Response Time	X0-X3 X4-X23
	OFF to ON Response	<100µs <8ms
	ON to OFF Response	<100µs <8ms
Relay Output Specifications	Fuses	None
	Number of Output Points	16
	Number of Commons	4 (isolated)
	Output Voltage Range	6-240VAC, 47-63Hz 6-27VDC
	Maximum Voltage	264VAC, 30VDC
	Maximum Current	2A/point 6A/common
	Maximum Leakage Current	0.1mA @ 246VAC
	Smallest Recommended Load	5mA @ 5VDC
	OFF to ON Response	<15ms
	ON to OFF Response	<10ms
	Status Indicators	Logic side
	Fuses	None (external recommended)

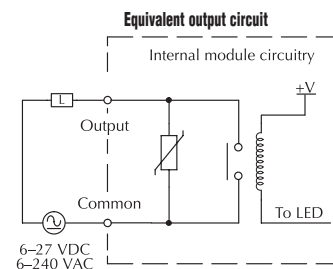
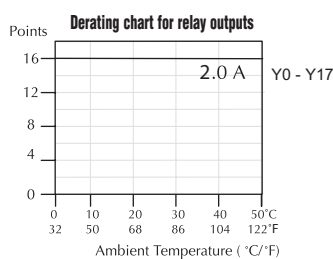
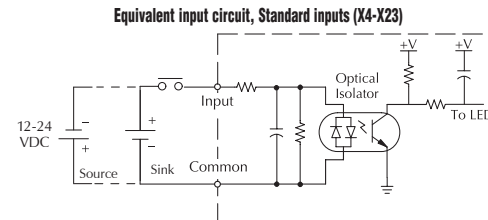
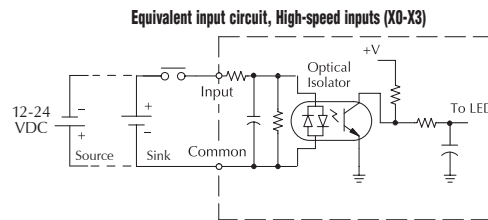
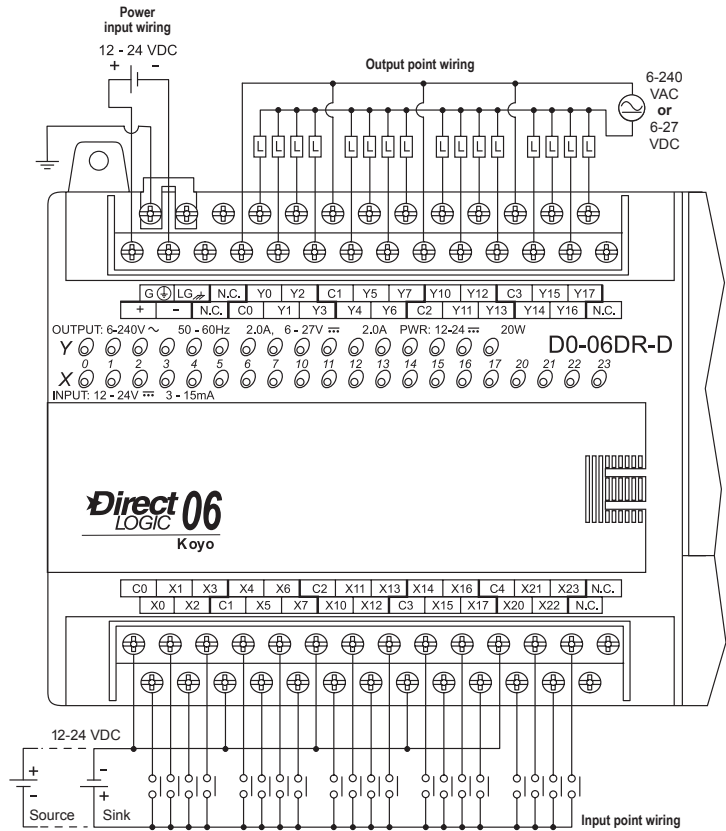

Typical Relay Life (Operations) at Room Temperature		
Voltage and Type of Load	Load Current	
	At 1A	At 2A
24 VDC Resistive	500K	250K
24 VDC Inductive	100K	50K
110 VAC Resistive	500K	250K
110 VAC Inductive	200K	100K
220 VAC Resistive	350K	200K
220 VAC Inductive	100K	50K

DL05/06 Option Modules

Need to expand your DL05 or DL06?

Customize your DL05 or DL06 PLC to fit your application by adding option modules in the built-in slots. You can add these features without adding size. We offer the following option modules:

- Discrete I/O modules
- High-resolution analog I/O modules
- Ethernet communications modules
- Data Communications module
- High-Speed Counter module
- DeviceNet slave module
- Profibus slave module
- CoProcessor module

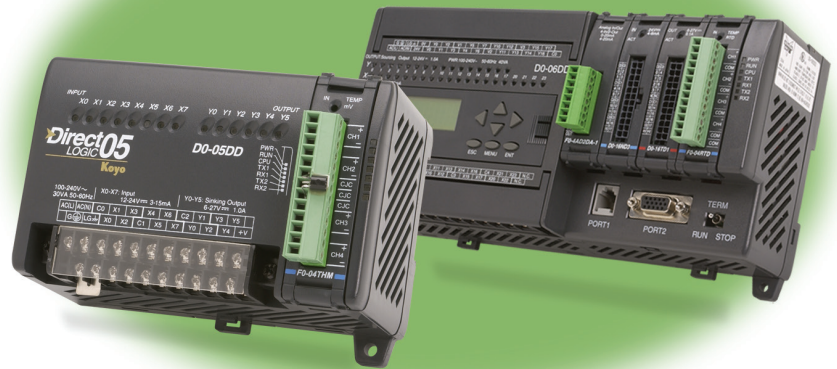

DL05 (only) Memory Module

Memory Module

D0-01MC \$55.00



DL05 flash memory

The standard DL05 PLC uses non-volatile flash memory to back-up the user program. Program data (V-memory) is backed by a super capacitor. If you need longer retention of program data, we recommend the D0-01MC. We also recommend the D0-01MC for applications that require transferring programs without a programming device or that require a real-time clock.

Simple and inexpensive

The D0-01MC slides easily into the option module slot in any DL05 PLC to back up PLC programs and data for extended periods of time.

Battery-backed RAM

The memory cartridge makes programs portable from one DL05 PLC to another. The memory map is identical to the internal memory in the DL05 PLC, so no program changes are necessary.

The on-board lithium battery lasts up to three years. If PLC power is lost and the battery is already dead, an on-board super capacitor backs up the memory four to seven days, allowing time to insert a new battery.

Real-time clock

Access the year, month, day of the week, hour, minute and second for event scheduling or data logging applications.

Operation

The D0-01MC installs into any of the DL05 PLCs. The MC module backs up all ladder and data in CMOS RAM.

The module's V-memory maps one-for-one to the PLC's memory locations. If the memory cartridge is inserted in the option slot, it automatically becomes the source of the controlling program.

You may choose to overwrite the PLC program, but it is not necessary. You can

transfer the program from the PLC to the module, or from the module to the PLC, or you can operate directly from the memory cartridge. By removing the module, you return control to the PLC's internal program.

Two pushbuttons on the face of the module initiate memory transfers. The pushbuttons are clearly marked to indicate the direction of the transfer, and an LED flashes to confirm the direction and success of the memory transfer.

A jumper enables/disables the write function in the D0-01MC. Write disable prevents overwriting of the module's memory. Write enable allows overwriting of the module's memory.

An LED alerts you to a low battery condition. If the battery drops below 2.5V the "BATT" LED comes on, and an internal bit is set. You can use the internal bit to activate alarm functions or to execute an orderly shutdown.

The date and time are easily set or accessed in the ladder logic program. Environmental specifications for the D0-01MC are the same as for the DL05 PLCs.

Firmware Requirements

Requires DL05 firmware V5.40 or newer. Older firmware will not recognize newer D0-01MC models.

DL05/06 DeviceNet™ Slave Comm. Module

DeviceNet Slave Module

D0-DEVNETS
\$100.00

The D0-DEVNETS option module transforms any DL05 or DL06 into a smart device node on your DeviceNet™ controller network. Now you don't have to turn to a more expensive PLC to get DeviceNet capability.

DeviceNet is a low-cost control bus used to connect field devices to PLCs and PCs. DeviceNet is designed to reduce the need for hard-wiring while providing device-level diagnostics. This industrial protocol links up to 64 nodes on a single network.

The D0-DEVNETS slave module slides into the option module slot of any DL05 or DL06 PLC. The module collects and reports all discrete I/O data to a DeviceNet master.

The D0-DEVNETS module has a removable connector that makes the four-wire connection easy to implement and maintain. The DeviceNet module incorporates advanced diagnostics not commonly found on traditional industrial networks. This module has the quick response time and high dependability expected from any DeviceNet device.

General Specifications	
DeviceNet Compatibility	Predefined Group 2 Master/Slave communications
Maximum Field Devices per Bus	64 (see table below)
Communication to Field Devices	Standard 4-wire shielded cable to cabinet connector, molded 4-wire cable @ up to 500Kbps to field devices
Module Connector	5-position removable terminal (European style)
Operating Temperature	0 to 55°C (32 to 131° F)
Storage Temperature	20 to 70°C (-4 to 158° F)
Relative Humidity	5 to 95% (non-condensing)
Environmental Air	No corrosive gases permitted
Vibration	MIL STD 810C 514.2
Shock	MIL STD 810C 516.2
Noise Immunity	Impulse noise 1μs, 1000V FCC class A RFI (144MHz, 430MHz 10W, 10cm)
Power Consumption	45mA @ 5VDC

Trunk Length		Bits per sec	Branch Length		Devices
Feet	Meters		Feet	Meters	
328ft	100m	500Kbps	20ft	6m	64
820ft	250m	250Kbps	20ft	6m	64
1,640ft	500m	125Kbps	20ft	6m	64

Other DeviceNet specifications, compatible products, and latest DeviceNet information are made available through:
 Open DeviceNet Vendor Association
 Phone: (954) 340-5412 Fax: (954) 340-5413
 Internet Address: <http://www.odva.org>
 e-mail: odva@powerinternet.com
 ODVA, Inc.
 20423 State Road 7
 Boca Raton, FL 33498

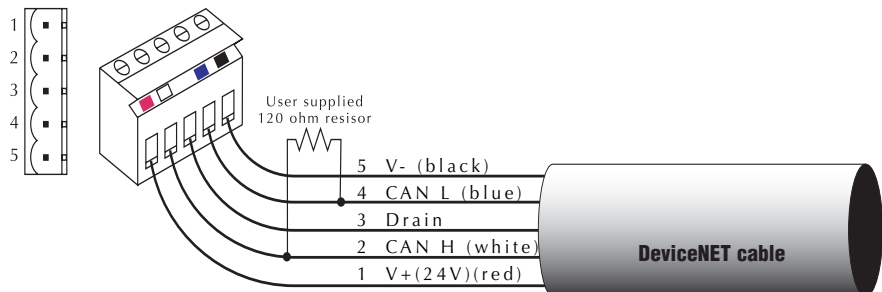
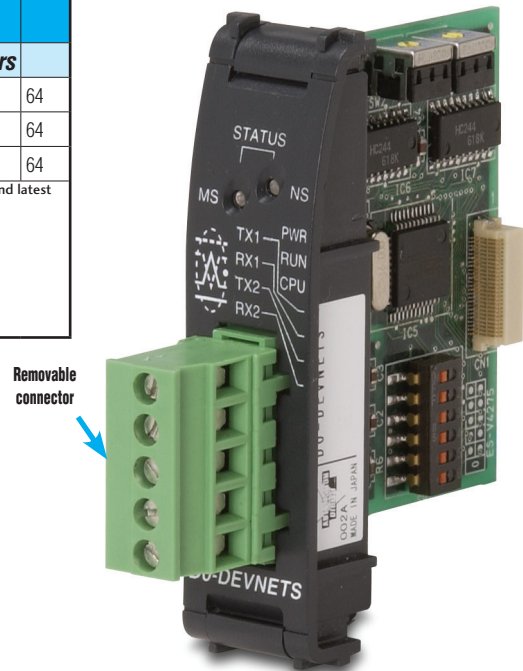

Company Information

Control Systems Overview

CLICK PLC

Do-More PLCs Overview

Do-More H2 PLC

Do-More T1H PLC

DirectLOGIC PLCs Overview

DirectLOGIC DL05/06

DirectLOGIC DL105

DirectLOGIC DL205

DirectLOGIC DL305

DirectLOGIC DL405

Productivity Controller Overview

Productivity 3000

Universal Field I/O

Software

C-More HMI

C-More Micro HMI

ViewMarq Industrial Marquees

Other HMI

Communications

Appendix Book 1

Terms and Conditions

DL05/06 Ethernet Communications Modules

Ethernet Communication Modules

H0-ECOM100 \$216.00



Overview

Ethernet Communications Modules offer features such as:

- High-speed peer-to-peer networking of PLCs
- Fast updates with **DirectSOFT** Programming Software
- High-performance access for Human Machine Interface (HMI), ERP, MES or other Windows-based software
- Industry standard Modbus TCP Client/Server Protocol
- Free SDK for custom drivers
- Easy setup

The Ethernet Communication (ECOM) Module represents a price breakthrough for high-speed peer-to-peer networking of PLCs. No longer are you forced to designate a single PLC to be the network master. Any PLC can initiate communications with any other PLC. Link your PLCs with PCs using industry standard Modbus TCP protocol connected through standard cables, hubs, and repeaters. Or, use our **KEPDirect** I/O Server to link your favorite HMI/SCADA, data historian, MES or ERP software to **DirectLOGIC** PLCs. Our **LookoutDirect** HMI and our **DataWorx** data collection software include ECOM drivers. **DirectSOFT** Programming Software can be used to monitor or update the program in any **DirectLOGIC** PLC on the network.

Simple connections

Use Category 5 UTP cables which can be run up to 100 meters between nodes. Use repeaters to extend distances and expand the number of nodes.

Choose your slot

The H0-ECOM100 module plugs into any option module slot of any DL05 PLC or DL06 PLC. The module maintains identification data, descriptive information, and communication parameters for PLC-to-PLC communications in flash memory. Disconnect power before installing or removing any PLC module.

Specifications	H0-ECOM100
Communications	10/100 BaseT Ethernet
Data Transfer Rate	100 Mbps
Link Distance	100 meters
Ethernet Port	RJ45
Ethernet Protocols	TCP/IP, IPX, Modbus TCP/IP DHCP, HTML Configuration
Power Consumption	300mA @ 5 VDC
Manufacturer	Host Automation Products, LLC

CPU	Firmware Required	DirectSOFT Required
DL05	ECOM100: Version 4.90 or later ECOM (retired): Version 4.60 or later	Version 3.0c or later
DL06	ECOM100: Version 1.80 or later ECOM (retired): Version 1.40 or later	Version 4.0, Build 16 or later

H0-ECOM100 IBox communications instructions

Over 40 Communications IBox instructions are available when using the H0-ECOM100 with a DL05/06 PLC and **DirectSOFT6** programming software. These easy-to-use instructions allow you to:

- Enable/disable module DHCP
- Read/write module IP, Gateway and Subnet Mask addresses
- Read/write module ID, Name and Description
- Send E-mail messages
- Read/Write PLC memory to networked Hx-ECOM100 modules
- Read/Write PLC memory to networked Hx-ECOM(-F) modules

See the following page for example Communications IBox instructions.



The H0-ECOM100 supports the Industry Standard Modbus TCP Client/Server Protocol



See the Communications section for details on Stride Ethernet Switches

DL05/06 Ethernet Communications Modules

Modbus TCP support

The H0-ECOM100 supports the industry standard Modbus TCP Client/Server protocol in addition to the standard IP and IPX protocols. This allows the DL06/06 PLC with an H0-ECOM100 module to serve as a client (master) or as a server (slave) on a Modbus TCP Ethernet network. The H0-ECOM100 can actively issue Modbus commands to other nodes or devices on the Modbus TCP network or simply respond to connected Modbus TCP clients.

ModbusTCP communications architecture

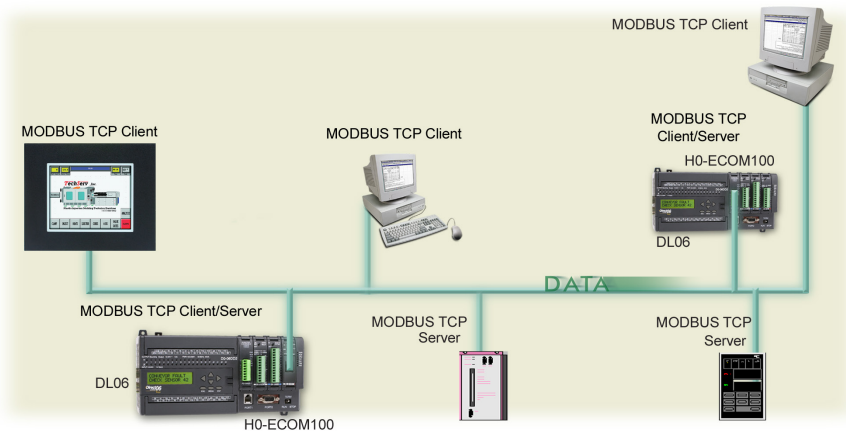

PLC-to-PLC communications

PLC-to-PLC or PLC to a Modbus TCP device communications can be accomplished using standard Read from Network (RX) and Write to Network (WX) instructions (all DL05/06 PLCs, all H0 series ECOMs and all *DirectSOFT* versions). If you're using our *DirectSOFT6* programming software, a DL05 or DL06 PLC and an H0-ECOM100, you can use fill-in-the-blank IBox instructions to simplify your communications programming. The H0-ECOM100 supports the ECOM100 Configuration IBox for use with the ECRX and ECWX IBox instructions to read/write to other ECOM100s. All H0 series ECOM modules support the NETCFG Configuration IBox for use with the NETRX and NETWX IBox instructions to read/write to other ECOM modules (remember *DirectSOFT5* or later is required). The Communications IBox instructions execute with built-in interlocking to greatly simplify communications programming.

ECOM100 Configuration IBox

ECOM100 Config	
ECOM100 #	K0
Slot	K1
Status	V2000
Workspace	V2100
Msg Buffer (65 WORDS)	V2000

ECOM100 Read Network IBox

ECOM100 RX Network Read	
ECRX	IB-740
ECOM100 #	K0
Workspace	V2200
Slave ID	K0
From Slave Element (Src)	C0
Number Of Bytes	K1
To Master Element (Dest)	V2000
Success	C0
Error	C0

H0-ECOM100 has e-mail capability!

The H0-ECOM100 Send EMail (ECEMAIL) IBox instruction will allow the module to behave as an e-mail client and send an SMTP request to your SMTP Server to send a specified e-mail message to the e-mail addresses in the IBox's To: field. The Body: field allows you to embed real-time data in your e-mail message. *DirectSOFT5* or later is required to use the IBox instructions.

NetEdit3 software

NetEdit3 Software ships free with the ECOM User Manual. Use NetEdit3 to configure the ECOM modules for your network. Flexible addressing allows you to use your choice of protocols and identifying methods. Assign each module a number or a name or both. You don't have to use an IP address, but you can if it's necessary for your network. NetEdit3 uses two protocols for PC-to-PLC communications: IPX and TCP/IP. The NetEdit3 screen displays all identifiers and troubleshooting information for each module on the network. You can use NetEdit3 to adjust parameters for PLC-to-PLC communications by clicking on **Advanced Settings**. The network identifiers can also be changed from *DirectSOFT* Programming Software.

ECOM100 Send EMail IBox

ECOM100 Send EMail	
ECEMAIL	IB-711
ECOM100 #	K0
Workspace	V2200
Success	C0
Error	C1
Error Code	V2100
To	docteam@work.com
Subject	Team Busy
Body	"Machine # V5010:B "went offline at" _time:24 "on" _date:us

DL05/06 Data Communications Module

Data Communications Module

D0-DCM \$146.00



Specifications		
Module Type	Intelligent	
Modules per CPU	DL05: one; DL06: up to four	
Field Wiring Connectors	Port 1: 6-pin RJ12 RS-232 Port 2: 15-pin HD-sub connector RS-232, RS-422/485	
Communications	Port 1	RS-232 signal levels, DirectNET slave, K-sequence slave, Modbus RTU slave, protocols, baud rate selectable from 9.6K to 115.2K baud, odd or no parity, selectable address, 8 data bits, one start/stop bit, DirectNET HEX or ASCII mode. (Defaults: slave, 9600bps, odd parity, address 1, auto-detect protocols)
	Port 2	RS-232/422/485 signal levels, DirectNET master/slave, K-sequence slave, Modbus RTU master/slave, non-sequence ASCII protocols, baud rate selectable from 300 to 115.2K baud, odd/even/no parity, selectable address, 7 or 8 data bits, one start bit, 1 or 2 stop bits, selectable timeout/response-delay times, DirectNET HEX or ASCII mode. (Defaults: slave, 19200bps, odd parity, address 1, eight data bits, one stop bit, auto-detect protocols)
Recommended Cable	RS-422: Belden 9729 or equivalent; RS-485: Belden 9841 or equivalent	
Internal Power Consumption	250mA maximum at 5VDC (supplied by base)	
Operating Environment	0°C to 60°C (32°F to 140°F), 5% to 95% humidity (non-condensing)	
Manufacturer	Koyo Electronics	
CPU	Firmware Required	DirectSOFT Required
DL05	Version 5.00 or later	Version 3.0c or later
DL06	Version 1.90 or later	Version 4.0, Build 16 or later. ASCII functions require version 5.1 or higher.

Overview

The D0-DCM Data Communications Module offers two communication ports for a variety of simultaneous communication possibilities:

- Extra communications port to connect a PC, operator interface, etc.
- Network interface to **DirectNET**
- Network interface to a Modbus network using the RTU protocol

The top RJ12 RS-232 port (Port 1) can be used for PLC programming, connection to an OI panel or as a single K-sequence, **DirectNet** or Modbus RTU slave. The 15-pin front port (Port 2) can be used for RS-232/422/485 communications and supports the following protocols: K-sequence slave, **DirectNET** master/slave and Modbus RTU master/slave.

Module Configuration

Since the D0-DCM does not have DIP switches to set baud rate, station address, parity, etc., ladder logic programming is required to configure its communication parameters, unless the default settings are acceptable for your application. If the D0-DCM is to be used as a network master, you must use ladder logic code to configure these parameters.

Extra communications ports for DL05/06

If additional communication ports are needed in the PLC, they can easily be added by installing DCM modules. Connect additional devices such as operator interfaces, PCs, etc. Set the DCM communication parameters using **DirectSOFT** programming software, connect the cables, and start transferring data. Make sure the connected device has a DL05/06 compatible driver.

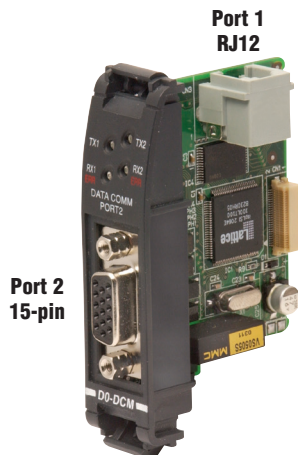
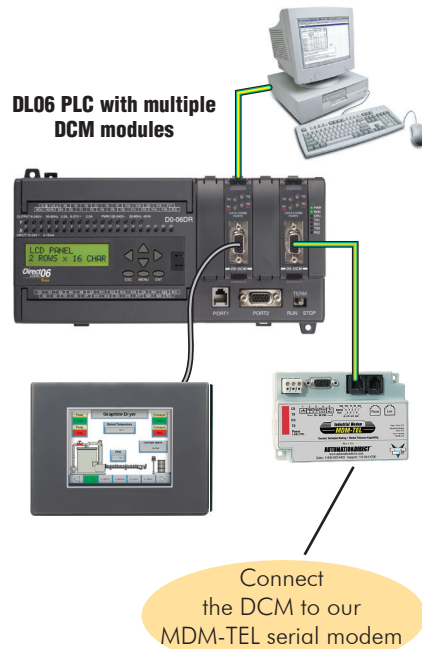

DL05/06 Data Communications Module

DirectNET network interface

The DCM can be used as a network interface for applications requiring data to be shared between PLCs, or between PLCs and an intelligent device such as a host PC. **DirectNET** allows you to upload or download virtually any type of system data including Timer/Counter data, I/O information, and V-memory information from any **DirectLOGIC** or compatible PLC. Port 2 on the DCM allows the DL05/06 to function as a **DirectNET** network master or slave using RS-422 communications (RS-232 can be used for single slave networks). Use RX and WX instructions in your RLL program to initiate communications.

DirectNET network

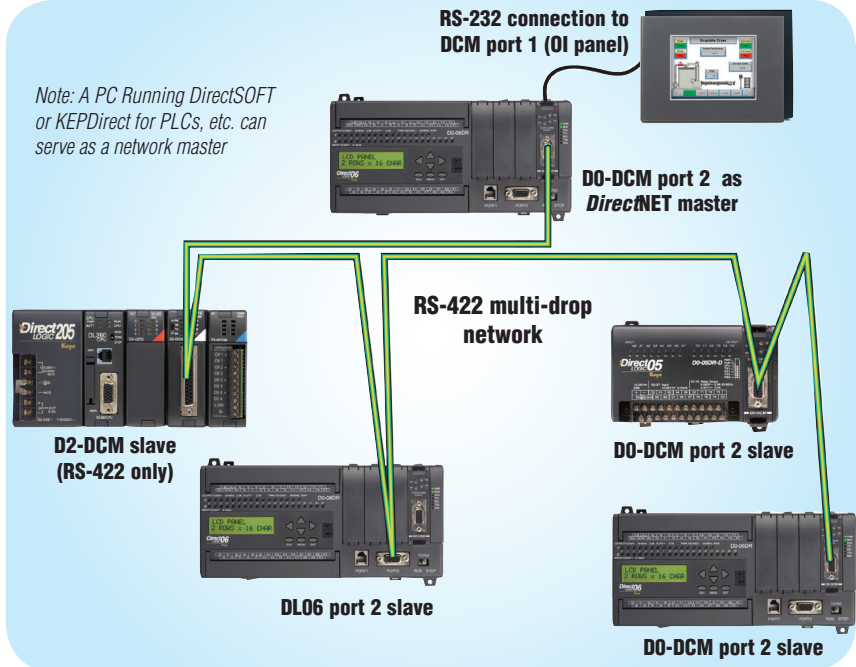

Modbus RTU interface

The DCM can be used as a master or slave station interface to connect your DL05/06 system to a Modbus® network using the Modbus RTU protocol. Port 2 on the DCM allows the DL05/06 to function as a Modbus RTU network master or slave using RS-422 or RS-485 communications (RS-232 can be used for single slave networks). Use RX and WX instructions in your RLL program to initiate communications.

Modbus RTU networks

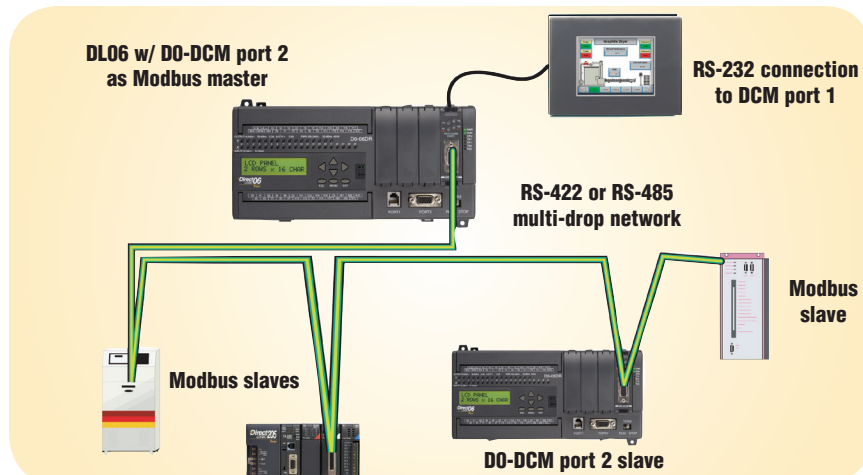
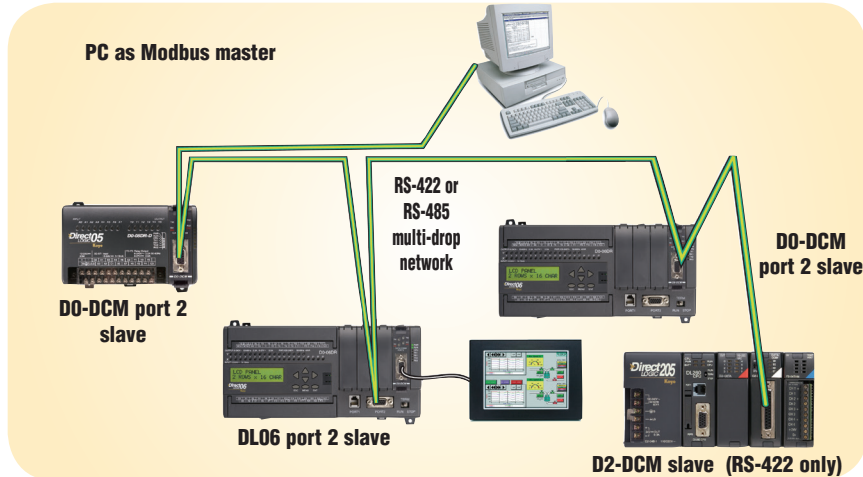

DL05/06 CoProcessor Module



Overview

The BASIC CoProcessor Module interfaces the DL05/06 family of programmable controllers with bar code readers, operator interface terminals, instrumentation equipment, computers and other serial devices.

BASIC CoProcessor applications

BASIC CoProcessors are designed for use with intelligent devices such as:

- Bar code readers
- Welders
- Board level controllers
- Serial printers
- Intelligent sensors
- Almost any device with an RS-232 or RS-485 port

They are also good solutions for applications requiring complex math, such as floating point math, sine, cosine, tangent, exponential, square roots, etc.

Features

- FACTS Extended BASIC and ABM Commander for Windows software for IBM PCs makes program development fast and simple. (The software is included with the CoPro module on CD-ROM). It allows online, full-screen BASIC program editing and the ability to upload/download programs on disk. The included CD has Modbus master and slave BASIC programs and other application examples.
- Non-volatile memory of up to 128K allows multiple program storage and execution, DL05/06 register expansion, and retentive data storage and retrieval.
- 100 MHz BASIC CoProcessor provides fast program execution independent of the CPU scan.
- Three buffered ports permit communication from the module to three external devices.
- The module is programmable from port 1 or 3 for complete serial port utilization without switching cables.
- A real-time clock/calendar maintains time/date with battery backup when power outages occur.
- Programmable time based BASIC interrupts to 5 ms.

- Direct access of up to 256 bytes of DL05/06 CPU memory per scan is possible. No supporting ladder logic is required.
- Floating point math solves complex formulas to eight significant digits.
- An RJ12 Port 1 and Port 3 splitter, included with the module, provides easy connection of RS-232 cables to both Port 1 and Port 3. (If you are using RTS1 and CTS1 for port 1, then port 3 is not available.)

Included with CoPro

The following items are included with the FO-CP128 module:

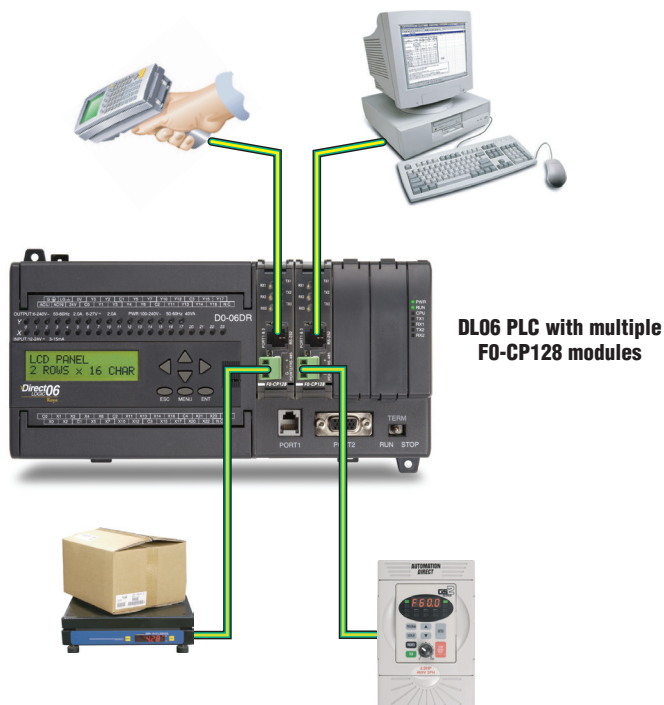

DL05/06 CoProcessor Module

Company
InformationControl Systems
Overview

CLICK PLC

Do-More
PLCs OverviewDo-More H2
PLCDo-More T1H
PLCDirectLOGIC
PLCs OverviewDirectLOGIC
DL05/06DirectLOGIC
DL105DirectLOGIC
DL205DirectLOGIC
DL305DirectLOGIC
DL405Productivity
Controller
OverviewProductivity
3000Universal
Field I/O

Software

C-More
HMIC-More Micro
HMIViewMarq
Industrial
Marquees

Other HMI

Communications

Appendix
Book 1Terms and
Conditions

Triple-Port BASIC CoProcessor Module Specifications	
Module Type	CoProcessor™, Intelligent
Modules per CPU	DL05: one; DL06: up to four
Communication	256 character type-ahead input buffer on all ports. Ports are independently programmed by software. Seven or eight data bits, one or two stop bits, even, odd, or no parity. XON/XOFF software flow control and RTS/CTS handshake.
Clock Speed	100MHz
User Memory	128K total (64K data, 64K program) non-volatile; Real time battery backed calendar/clock
F0-CP128 Ports	Port 1: RS-232 512K baud maximum Port 2: RS-485, 512K baud maximum Port3*: RS-232, 115.2K baud max. * Port 3 physically located in the same RJ12 jack as Port 1 (RS-232). Port 3 uses the RTS1/CTS1 pins on that jack. If you use these lines for other purposes (e.g. hardware handshaking on Port 1), then Port 3 cannot be used.
ABM Commander for Windows (CD included with module)	Standard programming/documentation software for IBM PCs is shipped with each coprocessor module Key features include: <ul style="list-style-type: none"> • Runs under Windows 98/ME/2000/XP • On-line full-screen BASIC program editing (similar to GW Basic, with industrial application enhancements added for easier programming) • Internal Editor for block copy, block move, search and replace • Text upload and download BASIC programs on disk • Binary upload and download BASIC programs and data on disk • Download control statement allows multiple programs to be downloaded and saved with one download file. • CD includes Modbus master and slave BASIC programs and other application examples
Field Termination	One RJ12 jack: Port 1 and 3 RS-232; One three-position removable terminal block: Port 2 RS-485
Indicator LEDs	RX1, TX1, RX2, TX2, RX3 (CTS1), TX3 (RTS1)
Power Consumption	150mA @ 5VDC
Operating Environment	0°C - 60°C (32°F - 140°F), 5% to 95% humidity (non-condensing)
Manufacturer	FACTS Engineering

CPU	Firmware Required	DirectSOFT Required
DL05	Version 5.00 or later	Version 3.0c or later
DL06	Version 1.90 or later	Version 4.0, Build 16 or later

DL05/06 PROFIBUS™ Slave Comm. Module

PROFIBUS Slave Communications Module
H0-PSCM \$309.00



Overview

You can add a DL05/06 PLC I/O sub-system to a PROFIBUS™ controller network. The H0-PSCM module allows the DL05/06 I/O sub-system to be linked with a PROFIBUS master controller. Profibus is a control bus that provides a common method to connect automation equipment with devices on a single network and significantly reduces hardwiring costs. PROFIBUS provides specifications for information exchanged between nodes, such as controller data associated with low level devices and configuration parameters that are individually related to system operations.

How it works

The H0-PSCM module is a PROFIBUS slave device which can be inserted into the option slot of a DL05 or a DL06 PLC. The H0-PSCM module is used to transfer blocks of data between a PROFIBUS master and a DL05/06 PLC. The user can choose up to four blocks of data to be transferred. The data blocks can range in size from 1 byte to 32 words and can be either input or output data. The data blocks can be mapped to real I/O within the PLC or user data areas of memory. The H0-PSCM module uses 'config' and 'parm' data, configured by the user with a program such as COM PROFIBUS, to determine what data types and addresses are to be transferred onto the PROFIBUS network. Once configured, the H0-PSCM will continually transfer the data to/from the PLC.

Specifications	
Module Location	PLC option slot
Module Type	Interface device
Maximum Expansion	126 stations, 32 stations per segment, 9 repeaters in a row
Communications	RS-485 PROFIBUS, PROFIBUS-DP. Baud rate selectable from 9.6Kbaud to 12M baud.
Module Connectors	PROFIBUS 9-pin D-shell, RJ-12 serial (firmware update only)
Internal Power Consumption	530mA maximum at 5VDC (supplied by PLC power supply)
Operating Environment	0°C to 60°C (32°F to 140°F), 5% to 95% humidity (non-condensing)
Manufacturer	Host Automation Products, LLC

CPU	Firmware Required	DirectSOFT Required
DL05	Version 4.60 or later	Version 3.0c or later
DL06	Version 1.40 or later	Version 4.0, Build 16 or later

Connect our DL05 or DL06 I/O...

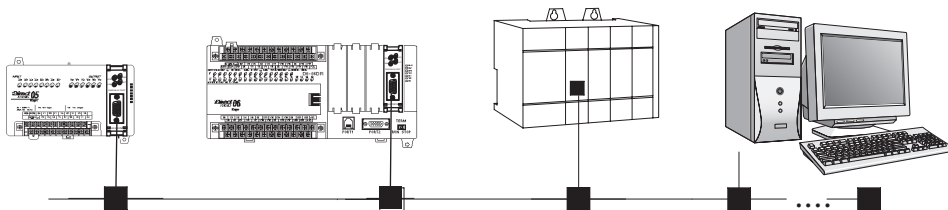

... to your PLC or PC based PROFIBUS Master.

HX-PSCM-M, the H0-PSCM PROFIBUS Slave Communications Module User Manual contains information pertaining to the I/O modules, power budgeting, installation and wiring.

DL05/06 PROFIBUS Slave Comm. Module

Company Information

Control Systems Overview

CLICK PLC

Do-More PLCs Overview

Do-More H2 PLC

Do-More T1H PLC

DirectLOGIC PLCs Overview

DirectLOGIC DL05/06

DirectLOGIC DL105

DirectLOGIC DL205

DirectLOGIC DL305

DirectLOGIC DL405

Productivity Controller Overview

Productivity 3000

Universal Field I/O

Software

C-More HMI

C-More Micro HMI

ViewMarq Industrial Marquees

Other HMI

Communications

Appendix Book 1

Terms and Conditions

Baud	Max. Segment Length		Max. Expansion	
	Feet	Meters	Feet	Meters
9.6 Kbps	3278	1000	32786	10000
19.2 Kbps	3278	1000	32786	10000
93.75 Kbps	3278	1000	32786	10000
187.5 Kbps	3278	1000	32786	10000
500 Kbps	1311	400	13114	4000
1.5 Mbps	655	200	6557	2000
3 Mbps	327	100	3270	1000
6 Mbps	327	100	3270	1000
12 Mbps	327	100	3270	1000

Recommended Cables	
Siemens	6XV1 830 0AH10
Belden	3079A

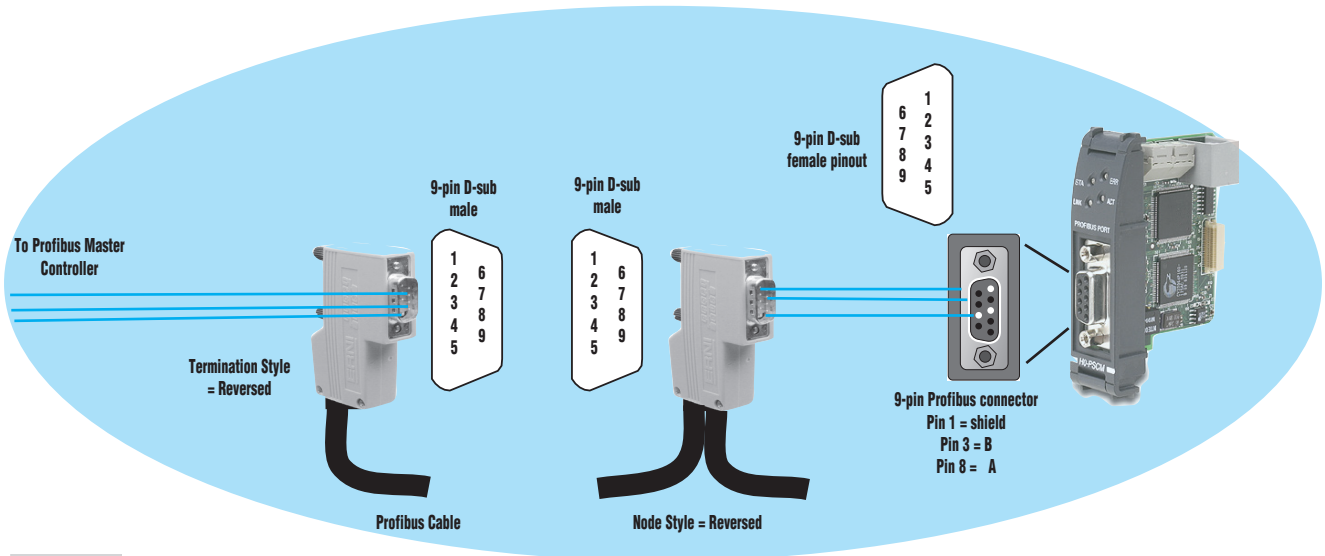

ERNI ERbic connectors for PROFIBUS networks

ERNI ERbic connectors are available for the PROFIBUS Slave Communications Module. They are available in node and termination reversed styles for the H0-PSCM and PC connections, horizontal or vertical cable entry, and termination or daisy-chain configurations.

ERNI ERbic connectors		
Part No.	Description	Device
103658	PROFIBUS-certified reverse node horizontal connector. 9-pin Male D-Sub	H2-PBC or any PROFIBUS ISA/PCI Personal Computer Master/Slave Card
103659	PROFIBUS-certified reversed termination horizontal connector. 9-pin Male D-Sub	H2-PBC or any PROFIBUS ISA/PCI Personal Computer Master/Slave Card

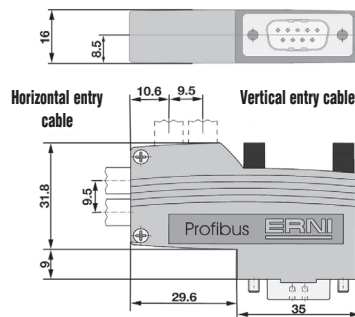

Note: Dimensions are in millimeters.

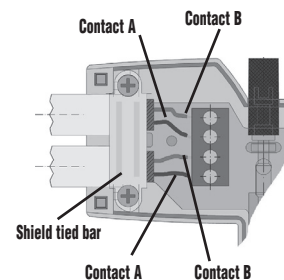

DL05/06 High-Speed Counter I/O Module

High-Speed Counter I/O Module

H0-CTRIO2 \$214.00



Overview

The High-Speed Counter I/O module is designed to accept high-speed pulse-type input signals for counting or timing applications and to provide high-speed pulse-type output signals for stepper/servo motor control, monitoring, alarm or other discrete control functions. The H0-CTRIO2 module offer great flexibility for applications that call for precise counting or timing, based on an input event or for high-speed control output applications.

The module has its own microprocessor and operate asynchronously from the PLC/controller. This means that the on-board outputs respond in real time to incoming signals so there is no delay waiting for the PLC/controller to scan I/O.

The module is designed to work with incremental encoders or other field devices that send pulse outputs.

Terminal block supplied. Replacement terminal block: Order part no. F0-IOCON.

H0-CTRIO2 features

The H0-CTRIO2 module offers the following I/O features:

- 4 DC sink/source inputs, 9-30VDC
- 2 isolated sink/source DC outputs, 5-36 VDC, 0.5A per point

Inputs supported:

- 1 quadrature encoder counter up to 250 KHz, or 2 single-channel counters also up to 250 KHz using module terminals A and B
- High-speed edge timers, dual edge timers, pulse catch, count reset, count inhibit, count capture or home search limits using module terminals C or D

Outputs supported:

- 2 independently configurable high-speed discrete outputs or 1 channel pulse output control (20 Hz-250 kHz)
- Pulse and direction or cw/ccw pulses supported for pulse output control
- Raw control of discrete output directly from user control program

Software configuration

All scaling and configuration is done via CTRIO Workbench, a Windows software utility program. This eliminates the need for PLC ladder programming or other interface device programming to configure the module. CTRIO Workbench runs under Windows 98/2000/XP/7 and NT 4.0 SP5 or later.

Typical applications

- High-speed cut-to-length operations using encoder input
- Pick-and-place or indexing functions controlling a stepper/servo drive
- Dynamic registration for web material control
- Accurate frequency counting for speed control with onboard scaling
- PLS (Programmable Limit Switch) functions for high-speed packaging, gluing, or labeling
- Sub 10 μsec pulse-catch capability for high-speed product detection
- Functions for level or flow

Supported systems

Multiple CTRIO2 modules can reside in the same PLC, provided the base power budget is adequate.

DirectLOGIC DL05 and DL06 PLCs

You can use the H0-CTRIO2 module with any of the DL05 and DL06 PLCs.

CPU	Firmware Required	DirectSOFT Required
DL05	Version 4.60 or later	Version 3.0c or later
DL06	Version 1.40 or later	Version 4.0, Build 16 or later

CTRIO Workbench main configuration screen

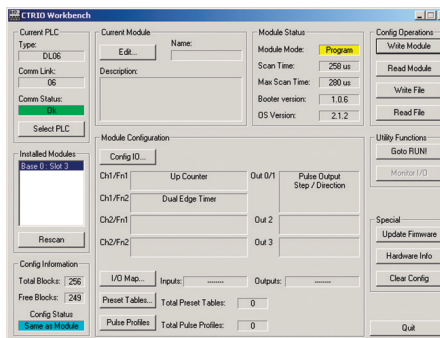

Configure I/O screen

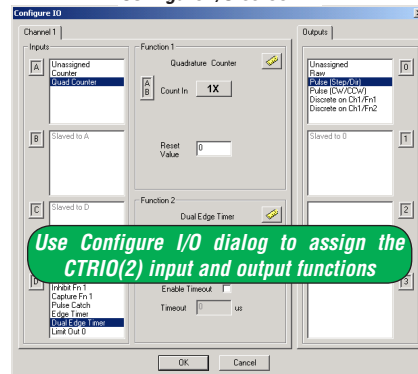

Use Configure I/O dialog to assign the CTRIO(2) input and output functions



NOTE: CTRIO WORKBENCH VERSION 2.2.0 IS REQUIRED TO USE H0-CTRIO2.

DL05/06 High-Speed Counter I/O Module

I/O Specifications

General	
Module Type	Intelligent
Modules Per Base	Limited only by power consumption
I/O Points Used	None, I/O map directly in PLC V-memory or PC control access
Field Wiring Connector	Removable terminal block
Internal Power Consumption	250 mA Max at +5V from base power supply; (All I/O in ON state at max voltage/current)
Operating Environment	32°F to 140°F (0°C to 60°C), humidity (non-condensing) 5% to 95%
Manufacturer	Host Automation Products, LLC
Isolation	2500V I/O to Logic (HO-CTRIO), 1500V I/O to Logic (HO-CTRIO2), 1000V among input channels and all outputs

HO-CTRIO2 Output Specifications		
Module	HO-CTRIO2	
Outputs	2 pts, independently isolated, current sourcing or sinking FET outputs: open drain and source with floating gate drive	
Voltage Range	5 - 36 VDC	
Maximum Voltage	36 VDC	
Output clamp Voltage	60 VDC	
Maximum Load Current	0.5A at 23 °C, 0.33A at 60 °C	
Maximum Load Voltage	33 VDC	
Maximum Leakage Current	100 µA	
Inrush Current	1.0A for 10 ms	
OFF to ON Response	less than 3 µsec	
ON to OFF Response	less than 3 µsec	
ON State V Drop	0.3V max.	
External Power Supply	For loop power only, not required for internal module function. User supplied power source required for stepper drive configuration.	
Overcurrent Protection	15A max Self resetting overcurrent protection	
Thermal Shutdown	Tjunction = 150°C	
Overtemperature Reset	Tjunction = 130°C	
Duty Cycle Range	1% to 99% in 1% increments (default = 50%)	
Configurable Presets	a) each output can be assigned one preset, or b) each output can be assigned one table of presets, one table can contain max. 128 presets, max. pre-defined tables = 255	
Maximum Output Frequency	Velocity Mode	65 kHz
	Run to Limit Mode	
	Run to Position Mode	
	Trapezoid	
	S-Curve	
	Symmetrical S-Curve	
	Dynamic Positioning	
	Home Search	
	Free Form	
	Dynamic Velocity	
	Dynamic Positioning Plus	
	Trapezoid Plus	
	Trapezoid with Limits	

HO-CTRIO2 Input Specifications	
Module	HO-CTRIO2
Inputs	4 pts sink/source 250 kHz Max
Minimum Pulse Width	0.5 µsec
Input Voltage Range	9-30 VDC
Maximum Voltage	30 VDC
Input Voltage Protection	Zener Clamped at 33 VDC
Rated Input Current	8 mA typical, 12 mA maximum
Minimum ON Voltage	9.0 VDC
Maximum OFF Voltage	2.0 VDC
Minimum ON Current	5.0 mA (9 VDC required to guarantee ON state)
Maximum OFF Current	2.0 mA
OFF to ON Response	Less than 0.5 µsec
ON to OFF Response	Less than 0.5 µsec

HO-CTRIO2 Input Resources	
Counter/Timer	2
Resource Options	1X, 2X, or 4X Quadrature, Up or Down Counter, Edge Timer, Dual Edge Timer, Input Pulse Catch, Reset, Inhibit, Capture
Timer Range / Resolution	4.2 billion (32 bits); 1 µsec
Counter Range	+ / - 2.1 billion (32 bits or 31 bits + sign bit)

HO-CTRIO2 Output Resources	
Module	HO-CTRIO2
Pulse output / Discrete outputs	Pulse outputs: 1 channel (20Hz-250kHz); Discrete outputs: 2 pts.
Resource Options	Pulse outputs: pulse/direction or cw/ccw
	Output Profiles: Trapezoid S-Curve Symmetrical S-Curve Dynamic Positioning Dynamic Velocity Home Search Free Form Dynamic Positioning Plus Trapezoid Plus Trapezoid w/Limits Velocity Mode Run to Limit Mode Run to Position Mode
	Discrete outputs: configurable for set, reset, pulse on, pulse off, toggle, reset count functions (assigned to respond to Timer/Counter input functions)
	Raw mode: Direct access to discrete output from user application program
Target Position Range	+ / - 2.1 billion (32 bits or 31 bits + sign bit)

Company
InformationControl Systems
Overview

CLICK PLC

Do-More
PLCs OverviewDo-More H2
PLCDo-More T1H
PLCDirectLOGIC
PLCs OverviewDirectLOGIC
DL05/06DirectLOGIC
DL105DirectLOGIC
DL205DirectLOGIC
DL305DirectLOGIC
DL405Productivity
Controller
OverviewProductivity
3000Universal
Field I/O

Software

C-More
HMIC-More Micro
HMIViewMarq
Industrial
Marquees

Other HMI

Communications

Appendix
Book 1Terms and
Conditions

DL05/06 High-Speed Counter I/O Module

Status indicators

H0-CTRIO2 LED Descriptions	
OK	Module OK
ER	User Program Error
A	Channel 1 Fn1 Status
B	Channel 1 Fn2 Status
Y0 - Y1	Output Status

H0-CTRIO2 LED Diagnostic Definitions		
OK	ERR	Description
ON	OFF	RUN Mode
ON	ON	Hardware Failure
Blinking	Blinking	Boot Mode - Used for Field OS Upgrades
Blinking	OFF	Program Mode
OFF	Blinking	Module Self-diagnostic Failure
OFF	ON	Module Error Due to Watchdog Timeout
OFF	OFF	No Power to Module

H0-CTRIO2 LED Diagnostic Definitions	
A	Blinks when Channel 1 Function 1 is counting or timing
B	Blinks when Channel 1 Function 2 is counting or timing
Y0 - Y1	Follow actual output state; ON = output is passing current

Installation and wiring

The H0-CTRIO2 module has one input channel, consisting of four optically isolated input points (pts. A-D on common M). The inputs can be wired to either sink or source current. The module has two optically isolated output points (pts. Y0-Y1 on common YC).

The outputs must be wired so positive current flows into the YC terminal and then out of the Yn terminal. The module's internal jumpers must be set to the High Side Common position for high side switching (sourcing) outputs or to the Low Side Common position for low side switching (sinking) outputs. Source operation is the factory default setting. See the schematic on the next page for sample jumper settings.

The module is configured, using CTRIO Workbench, to accommodate the user's application. The function of each input (counting, timing, reset, etc.) and output (pulse output, discrete output, etc.) is defined in the configuration of the module.

Terminal block supplied. Replacement terminal block: Order part no. F0-IOCON

See the notes below for further details about power source considerations, circuit polarities, and field devices.

Notes:

- Inputs (A, B, C, D) require user-provided 9-30 VDC power sources. Terminal M is the common for Channel 1 inputs. Maximum current consumption is 12 mA per input point.**
- Polarity of the input power sources can be reversed. Consideration must be given, however, to the polarity of the field device. Many field devices are designed for only one polarity and can be damaged if power wiring is reversed.**
- Outputs have one polarity only and are powered by user-provided 5-36 VDC power sources. The maximum allowable current per output circuit is 1A for the H0-CTRIO and 0.5A for the H0-CTRIO2. Module output jumpers must be set to the High side or Low side common position for Source/Sink applications. Refer to the diagrams on the next page for sample jumper settings.**

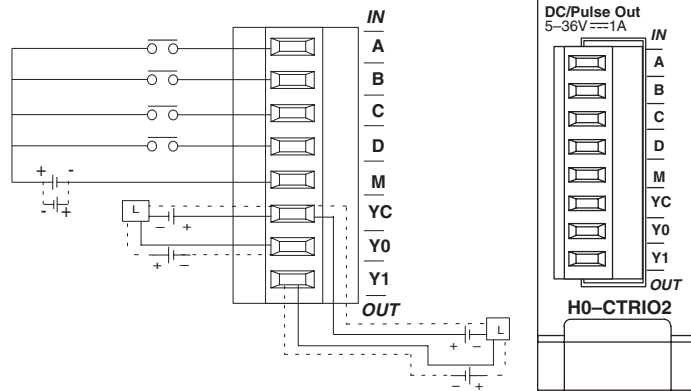

DL05/06 High-Speed Counter I/O Module

Company Information

Control Systems Overview

CLICK PLC

Do-More PLCs Overview

Do-More H2 PLC

Do-More T1H PLC

DirectLOGIC PLCs Overview

DirectLOGIC DL05/06

DirectLOGIC DL105

DirectLOGIC DL205

DirectLOGIC DL305

DirectLOGIC DL405

Productivity Controller Overview

Productivity 3000

Universal Field I/O

Software

C-More HMI

C-More Micro HMI

ViewMarq Industrial Marquees

Other HMI

Communications

Appendix Book 1

Terms and Conditions

Solid state input wiring device

DC types of field devices are configured to either sink or source current. This affects the wiring of the device to the H0-CTRIO2 module. Refer to the sinking/sourcing section in the Appendix for a complete explanation of sinking and sourcing concepts.

NPN Field Device (sink)

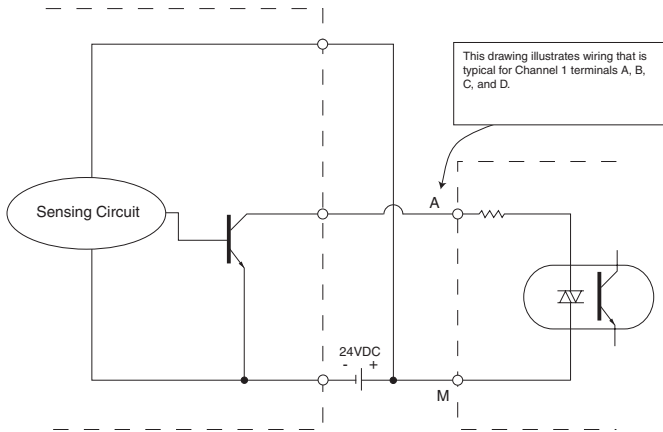

PNP Field Device (source)

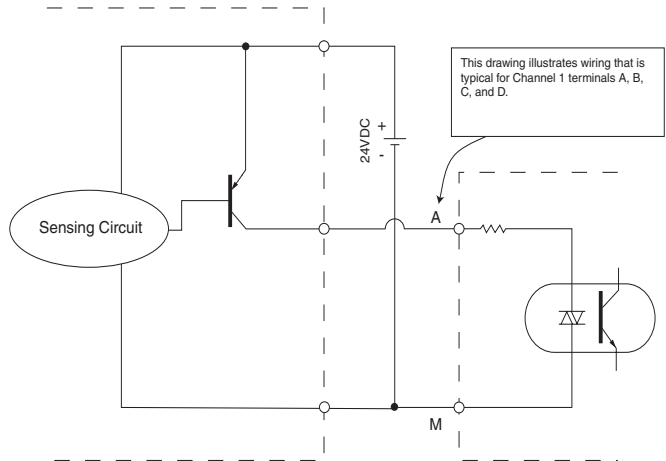

Pulse output schematic

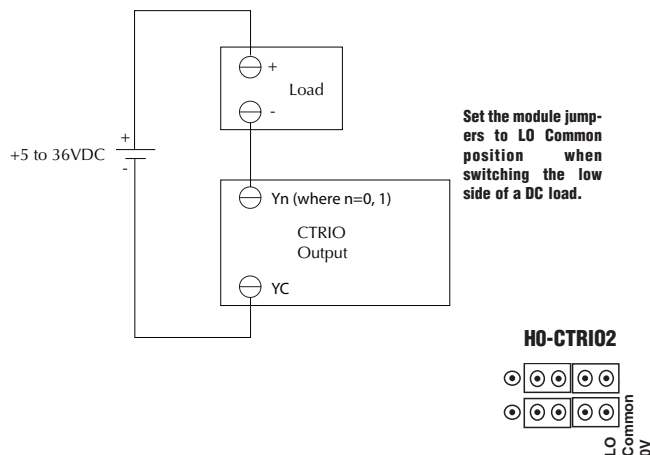
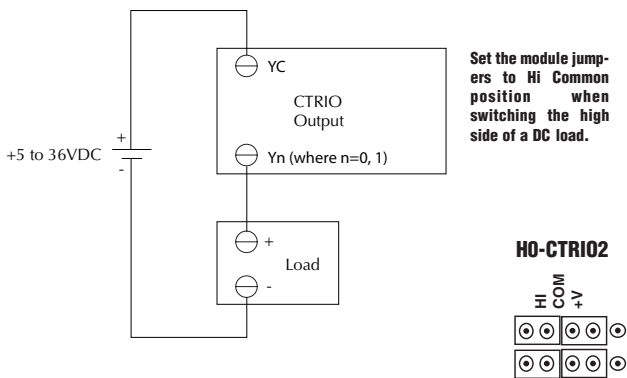

Stepper/servo drive wiring example

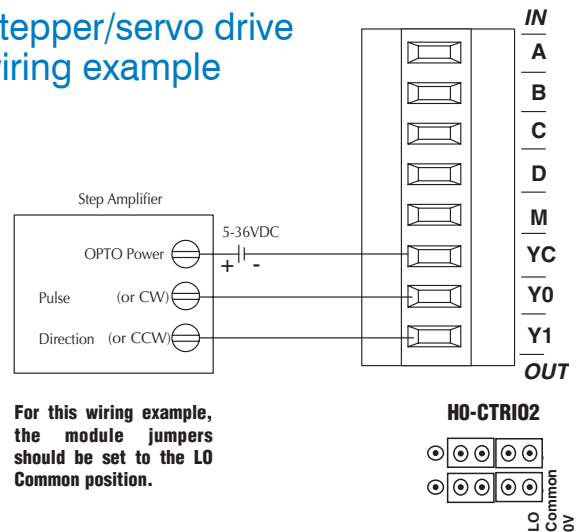

H0-CTRIO2 Jumper Location

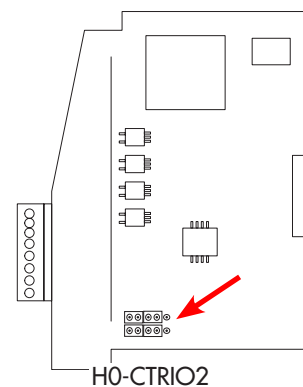

DL05/06 High-Speed Counter I/O Module

Fill-in-the-blank configuration software

The CTRIO Workbench is the software utility used to configure the CTRIO modules and to scale signals to desired engineering units. Workbench also allows you to perform various other functions, such as switching between the CTRIO's Program mode and Run mode, monitoring I/O status and functions, and diagnostic control of module functions. The latest version of the CTRIO Workbench utility can be downloaded for free at Host Engineering's Web site: www.hosteng.com.

CTRIO Workbench configure I/O setup

The Configure I/O dialog is the location where input and output functions are assigned to the module. The choice of input and output functions determines which options are available. The input function boxes prompt you with selections for supported functions. The Workbench software automatically disallows any unsupported configurations.



H0-CTRIO2

CTRIO Workbench main configuration screen

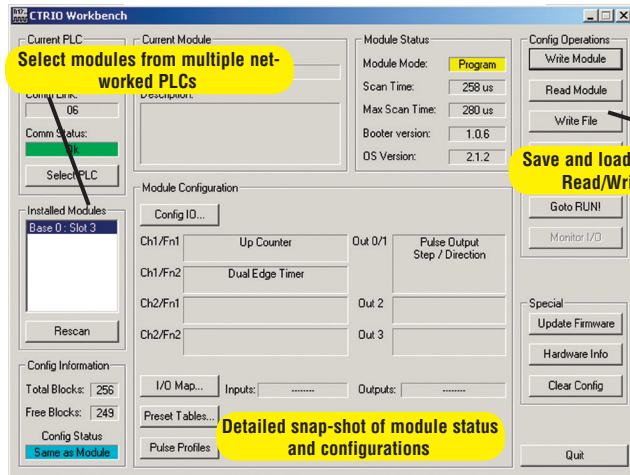

Configure I/O screen

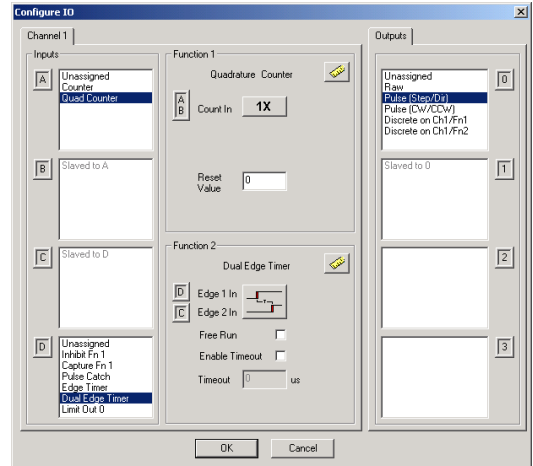

CTRIO Workbench diagnostics and monitoring

The Monitor I/O dialog is accessible from the main Workbench dialog when the module is in Run Mode. This allows for a convenient way to test and debug your configuration prior to installation. The Monitor I/O dialog is divided into three functional areas: Input Functions, Output Functions and System Functions. The data displayed under the Input Functions tab includes all input Dword parameters, status bits and the current status of each configured input and output function. The fields displayed under the Output Functions tab includes all output parameters and configuration information that can be altered during runtime and the bits that indicate successful transfers or errors. The System Functions can be used to read from or write to the CTRIO's internal registers.

Monitor I/O screen

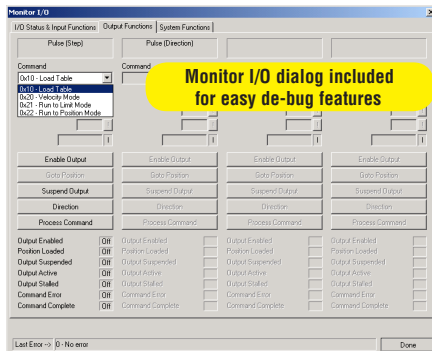

CTRIO Workbench on-board scaling

Scaling raw signals to engineering units is accomplished using the Scaling Wizard. The Scaling Wizard options are different for the Counter functions as compared with the Timer functions. "Position" and "Rate" scaling are available when you select a Counter function. "Interval" scaling is available when you select a Timing function.

Scaling Wizard screen

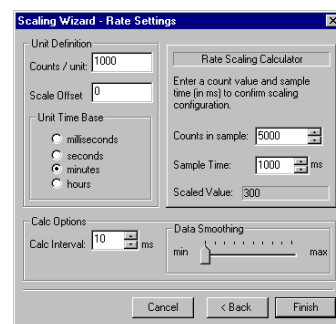

DL05/06 High-Speed Counter I/O Module

High-speed input operations

The CTRIO2 module is capable of a wide variety of high speed input and output operations all within one module. With single channel input and separate single channel output design, the H0-CTRIO2 module can satisfy both high-speed counting, timing, pulse catch operations, along with high speed discrete output or several profile choices of pulse output operations. Not all combinations of input functions and output functions are possible within the resources of the module, but the following examples are some of the most common applications for the H0-CTRIO2 module. Check out these examples and see how they relate to your high speed application needs.

High-speed timing

The H0-CTRIO2 module can be configured for timing functions based on count or rate. Using a common configuration of a proximity switch sensing the teeth on a gear, the module is able to calculate the velocity of the gear based on the rate it receives counts. This value can be scaled within the module to the engineering units required for the application.

High-speed timing application

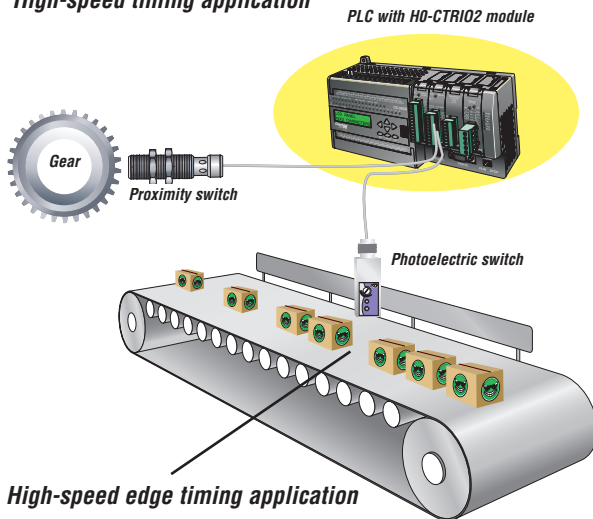

High-speed counting

The H0-CTRIO2 module can be configured for counting functions with an encoder input with available connections for external reset, capture and inhibit signals. In a simple cut-to-length application as shown, the encoder provides an input position reference for the material to the module. The module's high speed outputs are wired to the cutting device and to the clutch and/or braking device. When the count from the encoder is equal to a pre-programmed setpoint within the module, the high speed outputs are activated to stop and cut the material to a repeatable fixed length. Additionally, the clutch/brake signal can be used for an inhibit signal to not accumulate counts while the material is being cut.

High-speed cut-to-length application

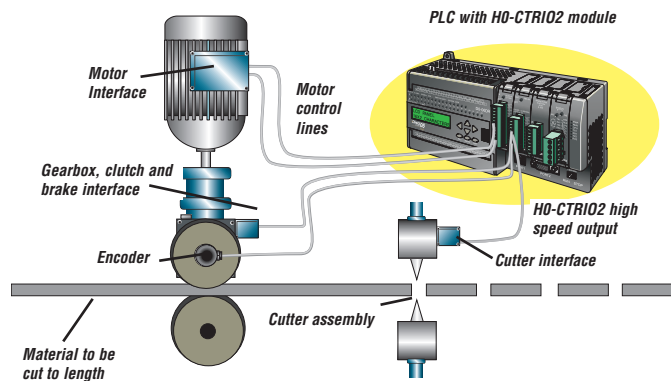

Using Configure I/O screen to configure H0-CTRIO2 module for high-speed counting

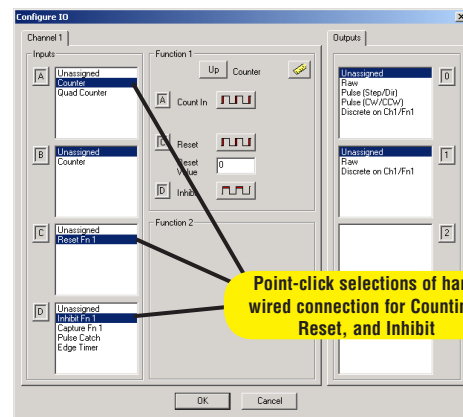

Using Configure I/O screen to configure H0-CTRIO2 module for high-speed timing

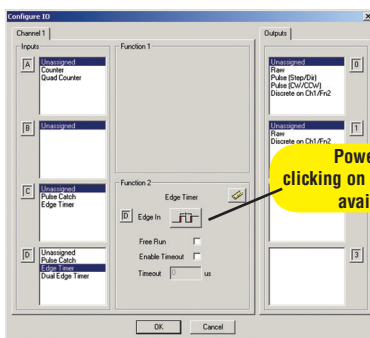

DL05/06 High-Speed Counter I/O Module

Pulse output operations

Using Edit Pulse Profile screen to select Trapezoid pulse output profile

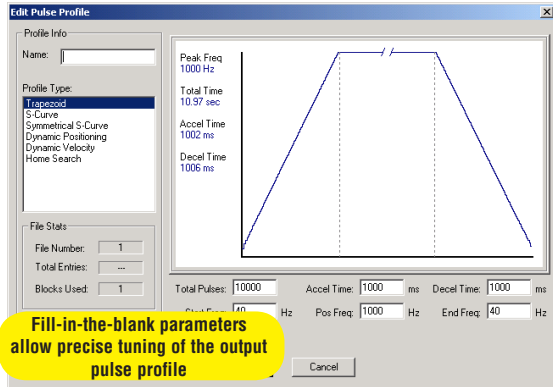

Pulse output for stepper/servo control

The H0-CTRIO2 module is capable of multiple configurations for pulse output control, most often when connected to a stepper or servo drive system. The module can deliver a pulse output signal up to a maximum of 250 kHz, along with support for pulse-and-direction or CW/CCW pulses. The available profile choices include Trapezoid, S-Curve, Symmetrical S-Curve, Dynamic Positioning, Dynamic Velocity, Home Search, Free Form, Dynamic Positioning Plus, Trapezoid Plus and Trapezoid w/Limits. All profiles can be easily configured using the CTRIO Workbench software with fill-in-the-blank parameter fields and a graphic representation of the selected profile. Three additional profiles are available that are completely controlled by the user program (no H0-CTRIO2 Workbench profile is configured). They are Velocity Mode, Run to Limit Mode and Run to Position Mode.

Example application

In a simple rotary indexing application, as shown above, a fixed Trapezoid profile is chosen. The H0-CTRIO2 module for this application is wired to a stepper drive for pulse-and-direction. The requirement for this application is to provide a smooth movement of the rotary table to allow product to be filled into individual containers an equal distance apart. The predetermined number of pulses required for each movement is entered into the CTRIO Workbench as "Total Pulses" along with the Starting Frequency, Ending Frequency, and Positioning Frequency (speed after acceleration). The Acceleration and Deceleration parameters are entered in units of time, so no ramp-distance calculations are required. After all parameters are entered, a graphical representation of the configured profile is shown automatically. Once the configuration has been downloaded to the module, all that is needed from the PLC CPU is the Enable Output signal to begin a movement.

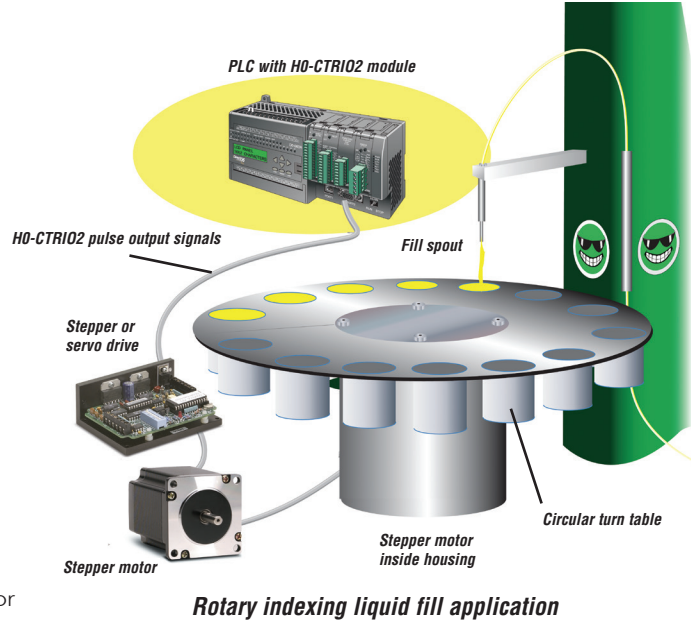

Other common pulse output applications:

- S-Curve accel/dec profile for signaling a stepper or servo drive that needs a curved acceleration and deceleration profile, i.e. for diminishing any initial "jerk" upon movement of static products, boxes on conveyors, liquids in containers on an indexer, printing registrations, etc.
- Dynamic Positioning for any run-to-a-specific-position requirement, either by a pre-programmed count of an external high speed discrete input wired to the module. This is popular in winding or webcontrol with any dynamic registration mark or variable speed requirement.
- Home search routines to seek a home position based on CTRIO module discrete input limit(s).

Example of S-Curve acceleration and deceleration pulse output profile

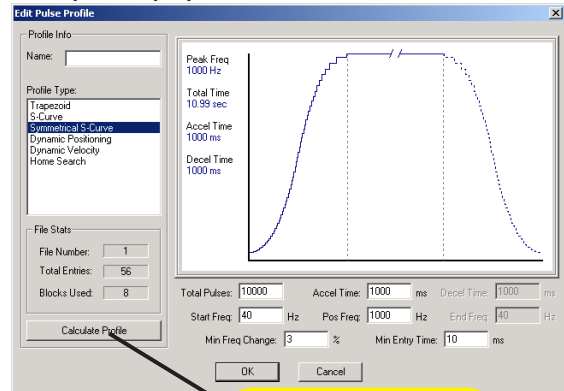

DL05/06 High-Speed Counter I/O Module

Combining high-speed input and pulse output operations

Using CTRIO Workbench to configure the module for simultaneous high-speed input and high-speed pulse output operation

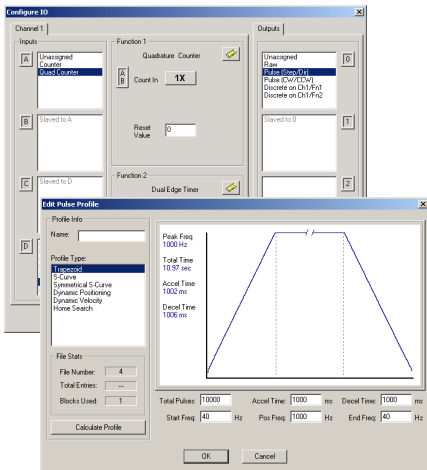

Multihead drill machine application

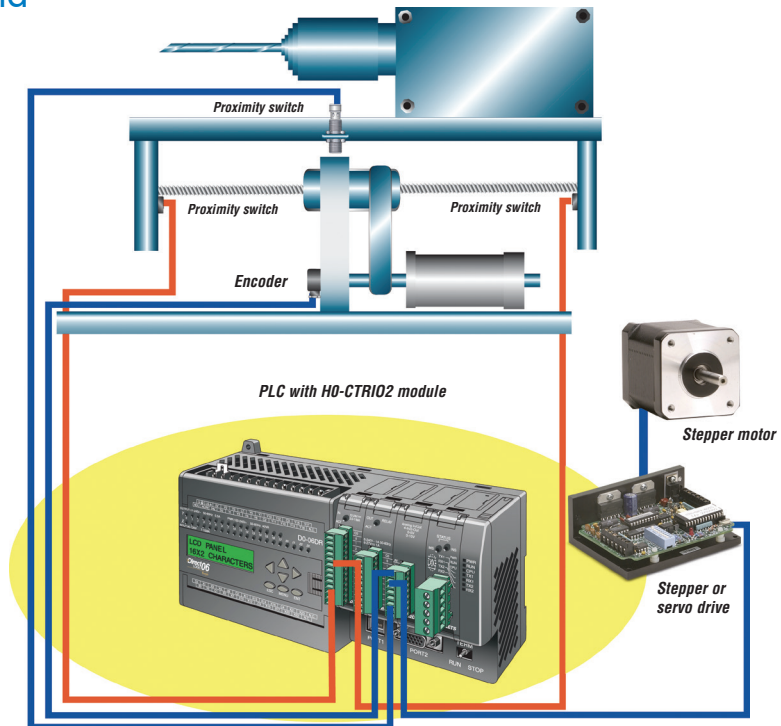

Use Encoder for Position

Three profiles offer the option to Use Encoder for Position. They are Dynamic Position Plus, Trapezoid Plus and Trapezoid w/ Limits. When Use Encoder for Position is enabled, the target positions are specified in units of the encoder and the move is complete when the encoder reaches that position, not when the output has finished generating a certain number of pulses. This functionality is useful for hitting a target position more accurately with a mechanical system that slips or has excessive lash.

Example application

In the simple drill head application shown above, the H0-CTRIO2 module pulse outputs are wired to a stepper or servo drive. The inputs are wired to an encoder attached to the lead screw on the movable portion of the drill head assembly. The H0-CTRIO2 module outputs a pulse train to the drive that allows the motor to spin the lead screw, making the drill move forward into the passing material. The encoder monitors the speed and position of the drill head. Proximity switches at each end act as limit switches ensuring the drill head will not over-travel. A home sensor is positioned in the middle of the assembly, which allows the PLC to reset the count.

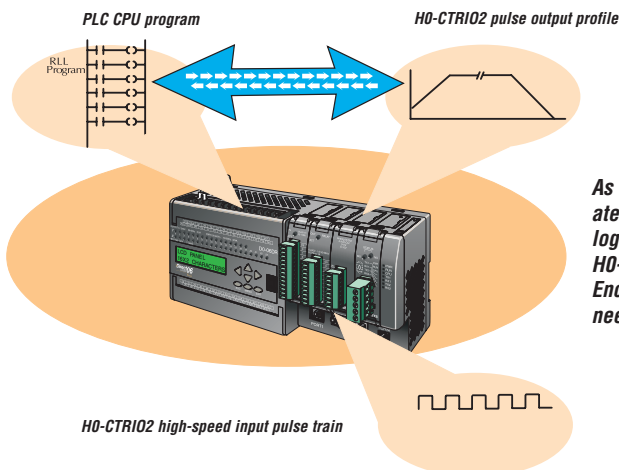

As shown in diagram on left, using an encoder to calculate the appropriate position for a move using H0-CTRIO2 is done manually through ladder logic. The inherent lag of doing this slows the process considerably. The H0-CTRIO2 can handle this functionality natively on-the-fly when Use Encoder for Position is enabled, eliminating the scan time delay and the need for extra ladder code.



Wiring Solutions

Wiring Solutions using the ZIPLink Wiring System

ZIPLinks eliminate the normally tedious process of wiring between devices by utilizing prewired cables and DIN rail mount connector modules. It's as simple as plugging in a cable connector at either end or terminating wires at only one end. Prewired cables keep installation clean and efficient, using half the space at a fraction of the cost of standard terminal blocks. There are several wiring solutions available when using the ZIPLink System ranging from

PLC I/O-to-ZIPLink Connector Modules that are ready for field termination, options for connecting to third party devices, GS, DuraPulse and SureServo Drives, and specialty relay, transorb and communications modules. Pre-printed I/O-specific adhesive label strips for quick marking of ZIPLink modules are provided with ZIPLink cables. See the following solutions to help determine the best ZIPLink system for your application.

Solution 1: DirectLOGIC I/O Modules to ZIPLink Connector Modules

When looking for quick and easy I/O-to-field termination, a ZIPLink connector module used in conjunction with a prewired ZIPLink cable, consisting of an I/O terminal block at one end and a multi-pin connector at the other end, is the best solution.

Using the PLC I/O Modules to ZIPLink Connector Modules selector tables located in this section,

1. Locate your I/O module/PLC.
2. Select a ZIPLink module.
3. Select a corresponding ZIPLink cable.



Solution 2: DirectLOGIC I/O Modules to 3rd Party Devices

For connecting I/O to another device within close proximity of the I/O modules, no extra terminal blocks are necessary when using the ZIPLink Pigtail Cables. ZIPLink Pigtail Cables are prewired to an I/O terminal block with color-coded pigtail with soldered-tip wires on the other end.

Using the I/O Modules to 3rd Party Devices selector tables located in this section,

1. Locate your PLC I/O module.
2. Select a ZIPLink pigtail cable that is compatible with your 3rd party device.



Solution 3: GS Series and DuraPulse Drives Communication Cables

Need to communicate via Modbus RTU to a drive or a network of drives?

ZIPLink cables are available in a wide range of configurations for connecting to PLCs and SureServo, SureStep, Stellar soft starters and AC drives. Add a ZIPLink communications module to quickly and easily set up a multi-device network.

Using the Drives Communication selector tables located in this section,

1. Locate your drive and type of communications.
2. Select a ZIPLink cable and other associated hardware.





Wiring Solutions

Solution 4: Serial Communications Cables

ZIPLink offers communications cables for use with *Direct*LOGIC, CLICK, and Productivity3000 CPUs, that can also be used with other communications devices. Connections include a 6-pin RJ12 or 9-pin, 15-pin and 25-pin D-sub connectors which can be used in conjunction with the RJ12 or D-Sub Feedthrough modules.

Using the **Serial Communications Cables** selector table located in this section,

1. Locate your connector type.
2. Select a cable.



Solution 5: Specialty ZIPLink Modules

For additional application solutions, ZIPLink modules are available in a variety of configurations including stand-alone relays, 24VDC and 120VAC transorb modules, D-sub and RJ12 feedthrough modules, communication port adapter and distribution modules, and *Sure*Servo 50-pin I/O interface connection.

Using the **ZIPLink Specialty Modules** selector table located in this section,

1. Locate the type of application.
2. Select a ZIPLink module.



Solution 6: ZIPLink Connector Modules to 3rd Party Devices

If you need a way to connect your device to terminal blocks without all that wiring time, then our pigtail cables with color-coded soldered-tip wires are a good solution. Used in conjunction with any compatible ZIPLink connector modules, a pigtail cable keeps wiring clean and easy and reduces troubleshooting time.

Using the **Universal Connector Modules and Pigtail Cables** table located in this section,

1. Select module type.
2. Select the number of pins.
3. Select cable.





PLC I/O Modules to ZIPLink Connector Modules - DL05/06

DL05/06 PLC Input Module ZIPLink Selector				
PLC		ZIPLink		
Input Module	# of Terms	Component	Module Part No.	Cable Part No.
D0-10ND3	13	Feedthrough	ZL-RTB20	ZL-D0-CBL13 *
D0-10ND3F	13	Feedthrough	ZL-RTB20	ZL-D0-CBL13 *
D0-16ND3	24	Feedthrough	ZL-RTB20	ZL-D0-CBL24 *L
		Sensor	ZL-LTB16-24	ZL-D0-CBL24 *L
F0-08NA-1	10	Feedthrough	ZL-RTB20	ZL-D0-CBL10 *

DL05/06 PLC Combo In/Out Module ZIPLink Selector				
PLC		ZIPLink		
Combo Module	# of Terms	Component	Module Part No.	Cable Part No.
D0-07CDR	10	Feedthrough	ZL-RTB20	ZL-D0-CBL10 *
D0-08CDD1	13	Feedthrough	ZL-RTB20	ZL-D0-CBL13 *

DL05/06 PLC Analog Module ZIPLink Selector				
PLC		ZIPLink		
Analog Module	# of Terms	Component	Module	Cable
F0-04AD-1	8	Feedthrough	ZL-RTB20	ZL-D0-CBL8 *
F0-04AD-2	8	Feedthrough	ZL-RTB20	ZL-D0-CBL8 *
F0-08ADH-1	13	Feedthrough	ZL-RTB20	ZL-D0-CBL13 *
F0-08ADH-2	13	Feedthrough	ZL-RTB20	ZL-D0-CBL13 *
F0-04DAH-1	13	Feedthrough	ZL-RTB20	ZL-D0-CBL13 *
F0-08DAH-1	13	Feedthrough	ZL-RTB20	ZL-D0-CBL13 *
F0-04DAH-2	13	Feedthrough	ZL-RTB20	ZL-D0-CBL13 *
F0-08DAH-2	13	Feedthrough	ZL-RTB20	ZL-D0-CBL13 *
F0-2AD2DA-2	8	Feedthrough	ZL-RTB20	ZL-D0-CBL8
F0-4AD2DA-1	8	Feedthrough	ZL-RTB20	ZL-D0-CBL8 *
F0-4AD2DA-2	8	Feedthrough	ZL-RTB20	ZL-D0-CBL8 *
F0-04RTD ²	Matched Only		See Note 2	
F0-04THM ²	Matched Only		See Note 2	

DL05/06 PLC Output Module ZIPLink Selector				
PLC		ZIPLink		
Output Module	# of Terms	Component	Module Part No.	Cable Part No.
D0-10TD1	13	Feedthrough	ZL-RTB20	ZL-D0-CBL13 *
D0-16TD1	24	Feedthrough	ZL-RTB20	ZL-D0-CBL24 *
		Fuse	ZL-RFU20 ³	ZL-D0-CBL24 *
		Relay (sinking)	ZL-RRL16-24-1	ZL-D0-CBL24 *
D0-10TD2	13	Feedthrough	ZL-RTB20	ZL-D0-CBL13 *
D0-16TD2	24	Feedthrough	ZL-RTB20	ZL-D0-CBL24 *
		Fuse	ZL-RFU20 ³	ZL-D0-CBL24 *
		Relay (sourcing)	ZL-RRL16-24-2	ZL-D0-CBL24 *
D0-08TR	10	Feedthrough	ZL-RTB20	ZL-D0-CBL10 *
F0-04TRS ¹	13	Feedthrough	ZL-RTB20	ZL-D0-CBL13 *

DL05/06 PLC Fixed I/O ZIPLink Selector				
PLC		ZIPLink		
PLC	# of Terms	Component	Module Part No.	Cable Part No.
DL05	18	Feedthrough	ZL-RTB20	ZL-D05-CBL18 *
DL06	20 (Input side only)	Feedthrough	ZL-RTB20	ZL-D06X-CBL20 *
	20 (Output side only)	Feedthrough	ZL-RTB20	ZL-D06Y-CBL20 *

* Select the cable length by replacing the * with: Blank = 0.5m, -1 = 1.0m, or -2 = 2.0m.

¹ Caution: The F0-04TRS relay outputs are derated not to exceed 2A per point when used with the ZIPLink wiring system.

² These modules are not supported by the ZIPLink wiring system.

³ Note: Fuses (5 x 20 mm) are not included. See Edison Electronic Fuse section for (5 x 20 mm) fuse. S500 and GMA electronic circuit protection for fast-acting maximum protection. S506 and GMC electronic circuit protection for time-delay performance. Ideal for inductive circuits.

To ensure proper operation, do not exceed the voltage and current rating of ZIPLink module. ZL-RFU20 = 2A per circuit; ZL-RFU40 = 400 mA per circuit.



NOTE: ZIPLINK CONNECTOR MODULES AND ZIPLINK CABLES SPECIFICATIONS ARE IN THE ZIPLINK CATALOG SECTION.



DL05/06 I/O Option Modules

FO-08SIM \$37.00

8-input simulator module

FO-08SIM Input Specifications	
Number of Inputs	8
Base Power Required (5VDC)	1 mA
Terminal Type	None
Status Indicator	None
Weight	1.6 oz. (45.36 g)

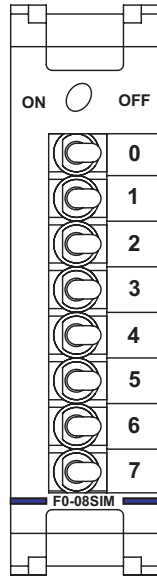

FO-08SIM addressing example

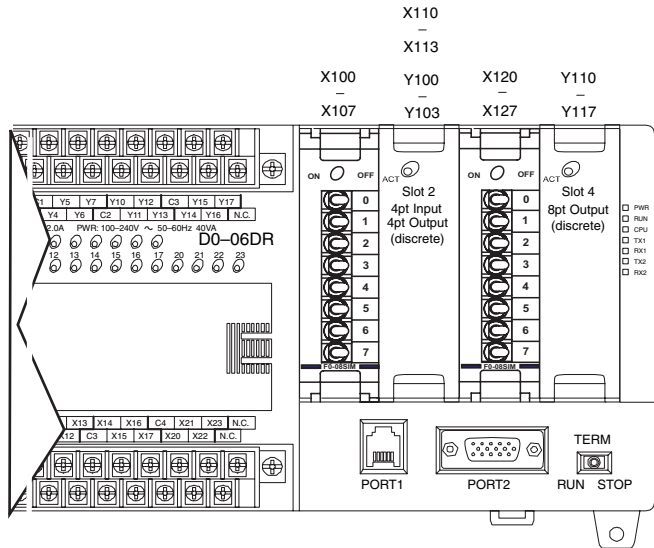

CPU	Firmware Required	DirectSOFT Required
DL05	Version 4.90 or later	Version 3.0c or later
DL06	Version 1.80 or later	Version 4.0, Build 16 or later

D0-10ND3 \$54.00

10-point DC input module

D0-10ND3 Input Specifications	
Number of Inputs	10 (sink/source)
Input Voltage Range	10.8-26.4 VDC
Peak Voltage	30.0 VDC
Input Current	Typical: 4.0 mA @ 12 VDC 8.5 mA @ 24 VDC
Maximum Input Current	11 mA @ 26.4 VDC
Input Impedance	2.8 KΩ @ 12-24 VDC
On Voltage Level	> 10.0 VDC
Off Voltage Level	< 2.0 VDC
Minimum ON Current	3.5 mA
Minimum OFF Current	0.5 mA
Off to On Response	2-8ms, Typ. 4ms
On to Off Response	2-8ms, Typ. 4ms
Status Indicators	Module activity: one green LED
Commons	2 (5 pts/common) isolated
Fuse	No fuse
Terminal Type (Included)	Removable: D0-ACC-4
Base Power Required (5V)	Typical. 35 mA (all pts. on)

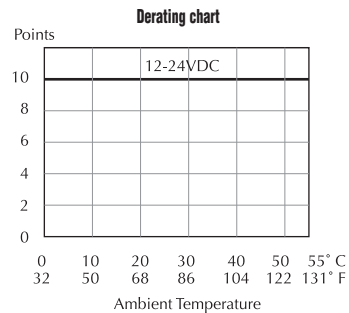
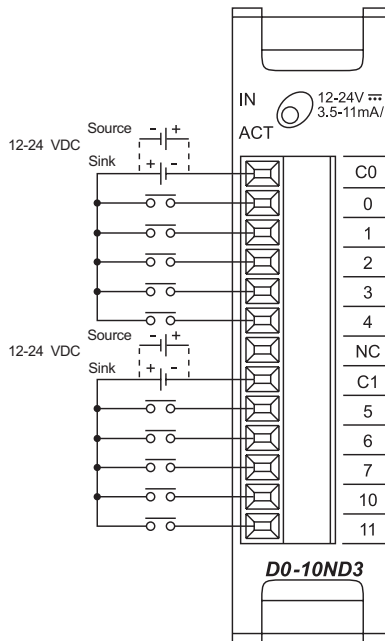

See Wiring Solutions for part numbers of ZIPLink cables and connection modules compatible with this I/O module.

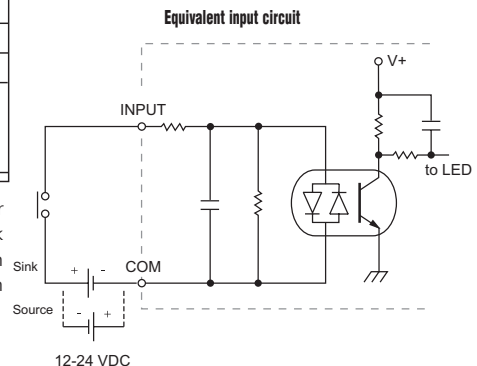

For "Sinking and Sourcing Concepts", see the Appendix section in this catalog.

DL05/06 I/O Option Modules

D0-10ND3F **\$62.00**

10-point DC fast input module

D0-10ND3F Input Specifications	
Number of Inputs	10 (sink/source)
Input Voltage Range	10.8-26.4 VDC
Peak Voltage	30.0 VDC
Input Current	Typical: 4.0 mA @ 12 VDC 8.5 mA @ 24 VDC
Maximum Input Current	11 mA @ 26.4 VDC
Input Impedance	2.8 KΩ @ 12-24 VDC
On Voltage Level	> 10.0 VDC
Off Voltage Level	< 2.0 VDC
Minimum ON Current	3.5 mA
Minimum OFF Current	0.5 mA
Off to On Response	2 ms, Typ. 1 ms
On to Off Response	2 ms, Typ. 1 ms
Status Indicators	Module activity: one green LED
Commons	2 (5 pts/common) isolated
Fuse	No fuse
Terminal Type (Included)	Removable: D0-ACC-4
Base Power Required (5V)	Typical: 35 mA (all pts. on)

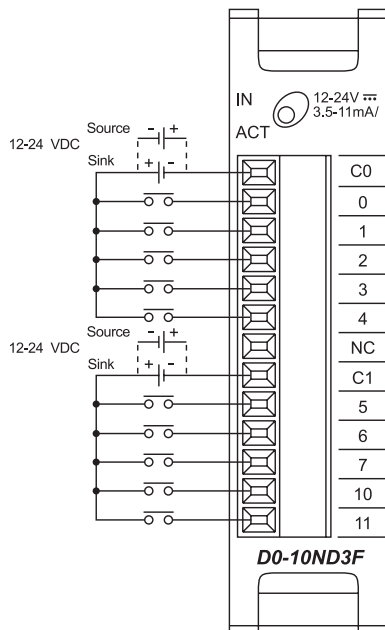

CPU	Firmware Required	DirectSOFT Required
DL05	Version 4.70 or later	Version 3.0c or later
DL06	Version 1.50 or later	Version 4.0, Build 16 or later



See Wiring Solutions for part numbers of ZIPLink cables and connection modules compatible with this I/O module.

Derating chart

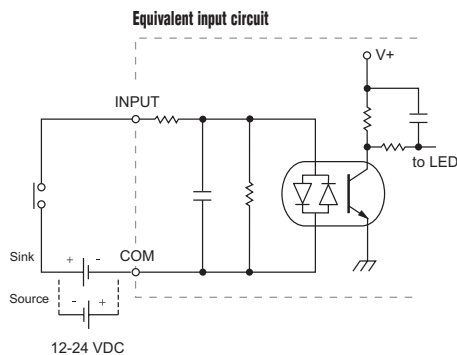
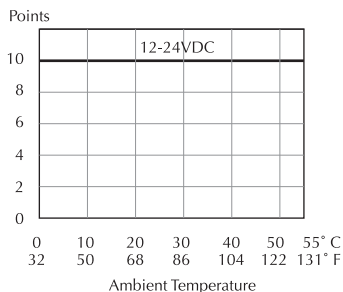

For "Sinking and Sourcing Concepts", see the Appendix section in this catalog.

DL05/06 I/O Option Modules

D0-16ND3 \$58.00

16-point DC input module

D0-16ND3 Input Specifications	
Number of Inputs	16 (sink/source)
Input Voltage Range	20-28VDC
Peak Voltage	30.0VDC
Input Current	Typical: 4.0mA @ 24VDC
Maximum Input Current	6mA @ 28VDC
Input Impedance	4.7KΩ @ 24VDC
On Voltage Level	> 19.0 VDC
Off Voltage Level	< 7.0 VDC
Minimum ON Current	3.5mA
Minimum OFF Current	1.5mA
Off to On Response	2-8ms, Typ. 4ms
On to Off Response	2-8ms, Typ. 4ms
Status Indicators	Module activity: one green LED
Commons	4 (4pts/common) isolated
Fuse	No fuse
Connector Type	24-pin Molex 43025-2400 (See ZIPLinks for wiring options)
Base Power Required	Typical. 35mA (all pts. on)

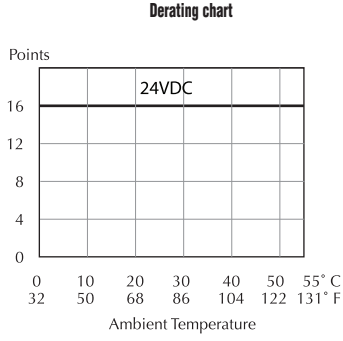
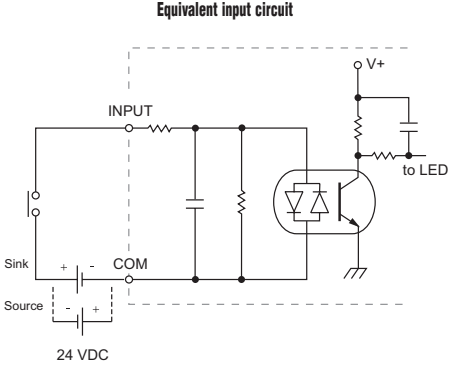
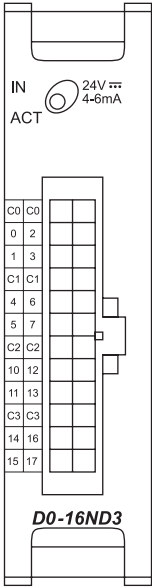

See Wiring Solutions for part numbers of ZIPLink cables and connection modules compatible with this I/O module.

Typical Wiring Example

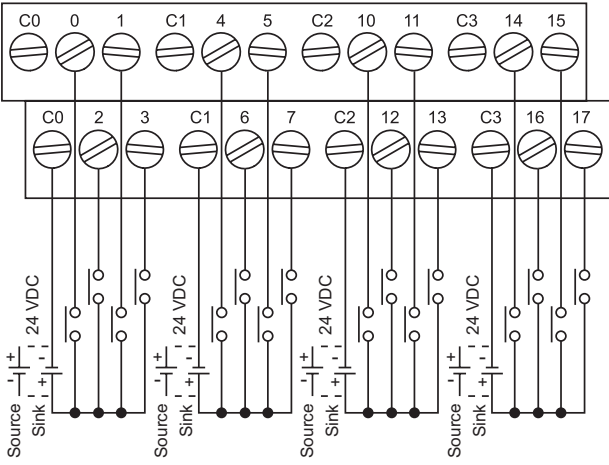

For "Sinking and Sourcing Concepts", see the Appendix section in this catalog.

- Company Information
- Control Systems Overview
- CLICK PLC
- Do-More PLCs Overview
- Do-More H2 PLC
- Do-More T1H PLC
- DirectLOGIC PLCs Overview
- DirectLOGIC DL05/06
- DirectLOGIC DL105
- DirectLOGIC DL205
- DirectLOGIC DL305
- DirectLOGIC DL405
- Productivity Controller Overview
- Productivity 3000
- Universal Field I/O
- Software
- C-More HMI
- C-More Micro HMI
- ViewMarq Industrial Marquees
- Other HMI
- Communications
- Appendix Book 1
- Terms and Conditions

DL05/06 I/O Option Modules

F0-08NA-1 **\$50.00**

8-point AC input module

F0-08NA-1 AC Input Specifications	
Number of Inputs	8
Input Voltage Range	80-132VAC (90-150VDC)
AC Frequency	47-63Hz
Input Current	4.0mA @ 132VAC
Input Impedance	33KΩ
On Voltage Level	80VAC minimum
Off Voltage Level	20VAC maximum
Minimum On Current	2.4mA
Maximum Off Current	1.6mA
Off to On Response	< 20ms
On to Off Response	< 10ms
Status Indicators	None
Commons	2 (4 pts/common) isolated
Fuse	No fuse
Terminal Type (Included)	Removable: D0-ACC-4
Base Power Required (5V)	5mA (all points ON)

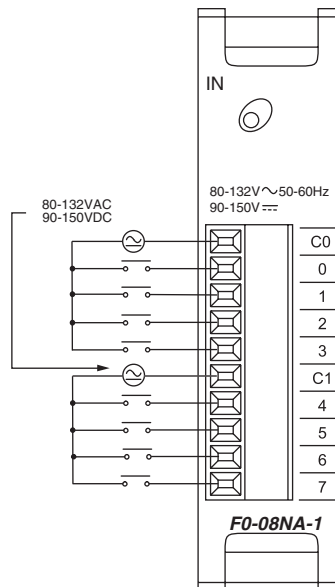

CPU	Firmware Required	DirectSOFT Required
DL05	Version 4.70 or later	Version 3.0c or later
DL06	Version 1.50 or later	Version 4.0, Build 16 or later



See Wiring Solutions for part numbers of ZIP Link cables and connection modules compatible with this I/O module.

Derating chart

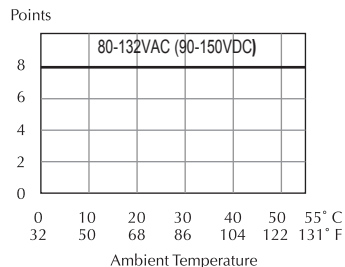

Equivalent input circuit

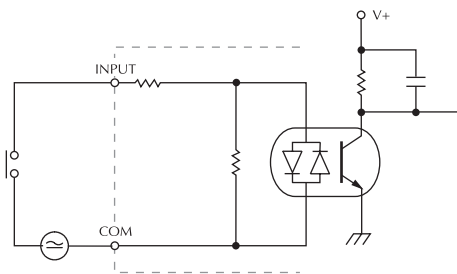

DL05/06 I/O Option Modules

D0-10TD1 \$63.00

10-point DC output module

D0-10TD1 Output Specifications	
Number of Outputs	10 (sinking)
Operating Voltage Range	6-27VDC
Output Voltage Range	5-30VDC
Peak Voltage	50.0VDC
Maximum Output Current	0.3A/point, 1.5A/common
Minimum Output Current	0.5mA
Maximum Leakage Current	15µA @ 30.0VDC
On Voltage Drop	0.5VDC @ 0.3A
Maximum Inrush Current	1A for 10ms
Off to On Response	< 10µs
On to Off Response	< 60µs
Status Indicators	Module activity: one green LED
Commons	2 (5 points/common)
Fuse	No fuse
Terminal Type (Included)	Removable: D0-ACC-4
External DC Power Required	20-28VDC max 200mA (all pts. on)
Base Power Required (5V)	Max. 150mA (all pts. on)

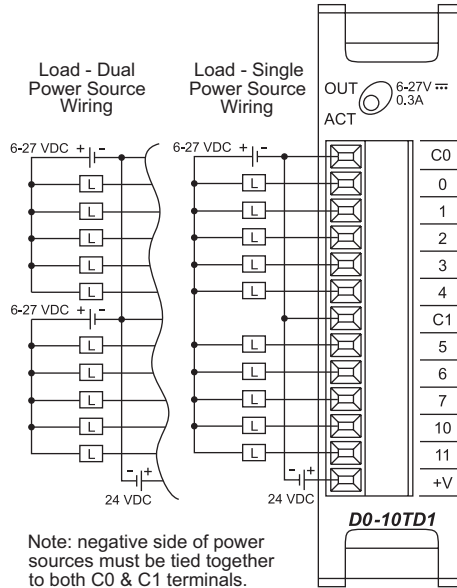

See Wiring Solutions for part numbers of ZIPLink cables and connection modules compatible with this I/O module.

Derating chart

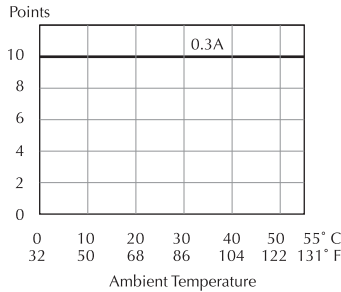

Equivalent output circuit

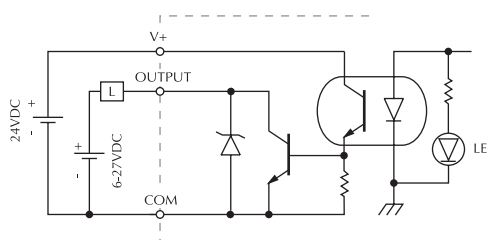

DL05/06 I/O Option Modules

D0-16TD1 **\$64.00**

16-point DC output module

D0-16TD1 Output Specifications	
Number of Outputs	16 (sinking)
Operating Voltage Range	6-27VDC
Output Voltage Range	5-30VDC
Peak Voltage	50.0VDC
Maximum Output Current	0.1A/point, 0.8A/common
Minimum Output Current	0.5mA
Maximum Leakage Current	15µA @ 30.0VDC
On Voltage Drop	0.5VDC @ 0.1A
Maximum Inrush Current	1A for 10ms
Off to On Response	< 0.5ms
On to Off Response	< 0.5ms
Status Indicators	Module activity: one green LED
Commons	2 (8 points/common)
Fuse	No fuse
Connector Type	24-pin Molex 43025-2400 (see ZIPLinks for wiring options)
External DC Power Required	20-28VDC max 70mA (all pts. on)
Base Power Required (5V)	Max. 200mA (all pts. on)



See Wiring Solutions for part numbers of ZIPLink cables and connection modules compatible with this I/O module.

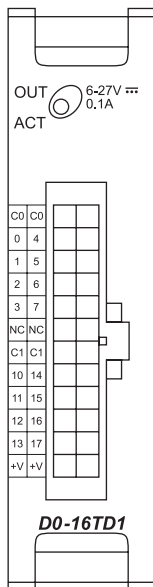

Equivalent output circuit

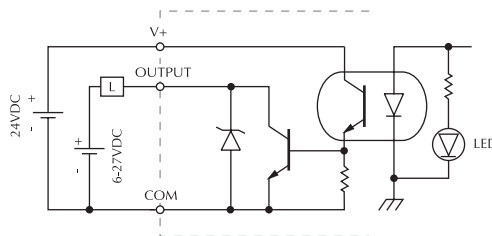

Derating chart

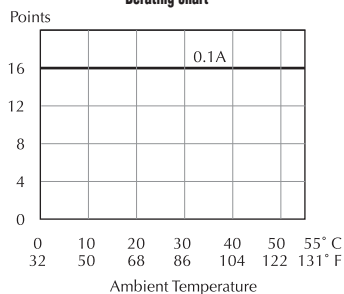

Typical Wiring Example

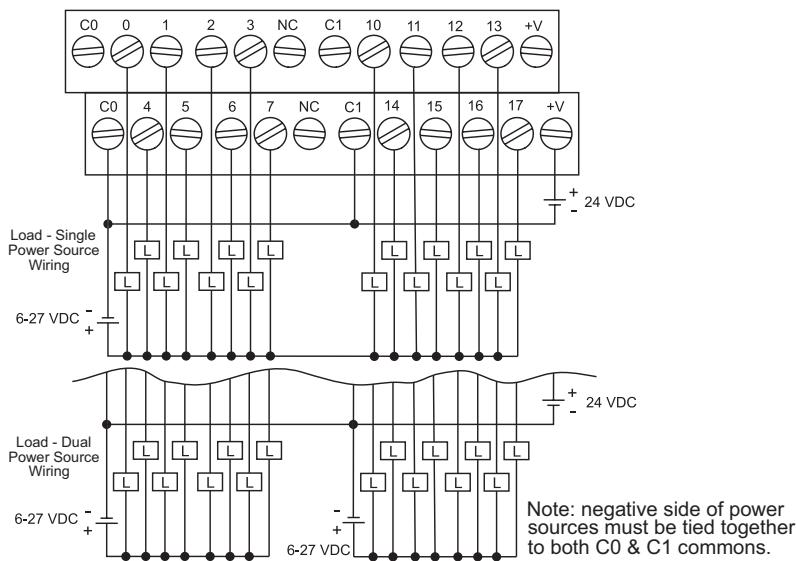

DL05/06 I/O Option Modules

D0-10TD2 **\$63.00**

10-point DC output module

D0-10TD2 Output Specifications	
Number of Outputs	10 (sourcing)
Peak Voltage	50.0VDC
Maximum Output Current	0.3A/point, 1.5A/common
Minimum Output Current	0.5mA
Maximum Leakage Current	1.5µA @ 26.4VDC
On Voltage Drop	1.0VDC @ 0.3A
Maximum Inrush Current	1A for 10ms
Off to On Response	< 10µs
On to Off Response	< 60µs
Status Indicators	Module activity: one green LED
+V Terminals & Common	2 (5 points/+V Term.) Isolated, 1 Common
Fuse	No fuse
Terminal Type (Included)	Removable: D0-ACC-4
Base Power Required (5V)	Max. 150mA (all pts. on)

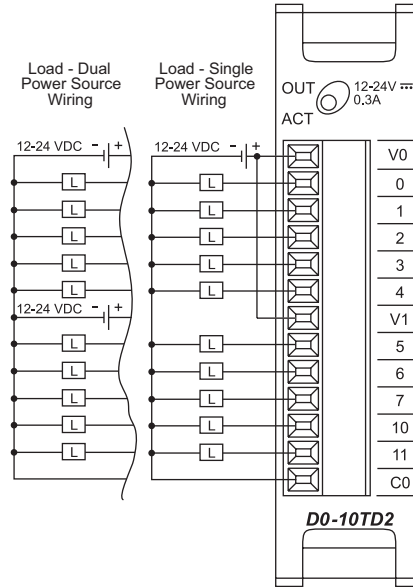

See Wiring Solutions for part numbers of ZIP Link cables and connection modules compatible with this I/O module.

Derating chart

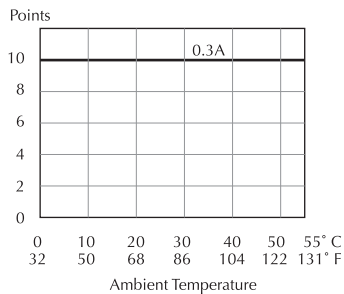

Equivalent output circuit

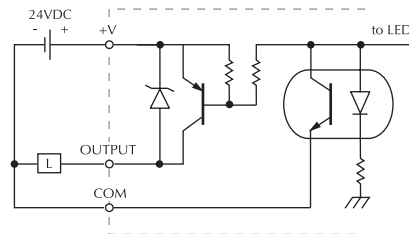

DL05/06 I/O Option Modules

D0-16TD2 **\$64.00**

16-point DC output module

D0-16TD2 Output Specifications	
Number of Outputs	16 (sourcing)
Peak Voltage	50.0VDC
Maximum Output Current	0.1A/point, 0.8A/common
Minimum Output Current	0.5mA
Maximum Leakage Current	1.5µA @ 26.4VDC
On Voltage Drop	1.0VDC @ 0.1A
Maximum Inrush Current	1A for 10ms
Off to On Response	< 0.5ms
On to Off Response	< 0.5ms
Status Indicators	Module activity: one green LED
+V Terminals & Common	2 (8 points/+V Term.) Isolated, 1 Common
Fuse	No fuse
Connector Type	24-pin Molex 43025-2400 (see ZIPLinks for wiring options)
Base Power Required (5V)	Max. 200mA (all pts. on)

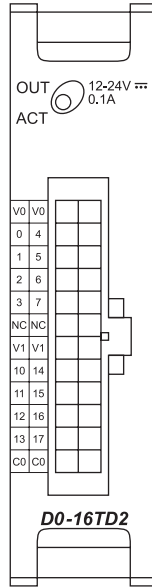

Equivalent output circuit

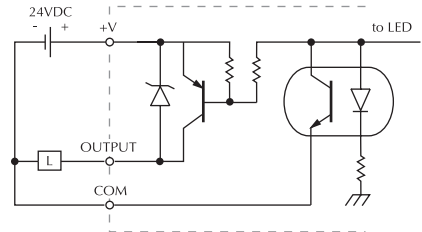

Derating chart

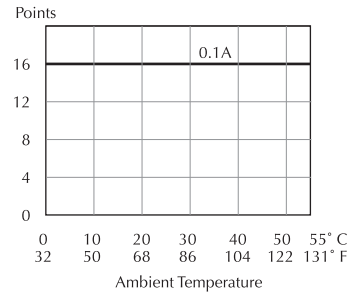

See Wiring Solutions for part numbers of ZIPLink cables and connection modules compatible with this I/O module.

Typical Wiring Example

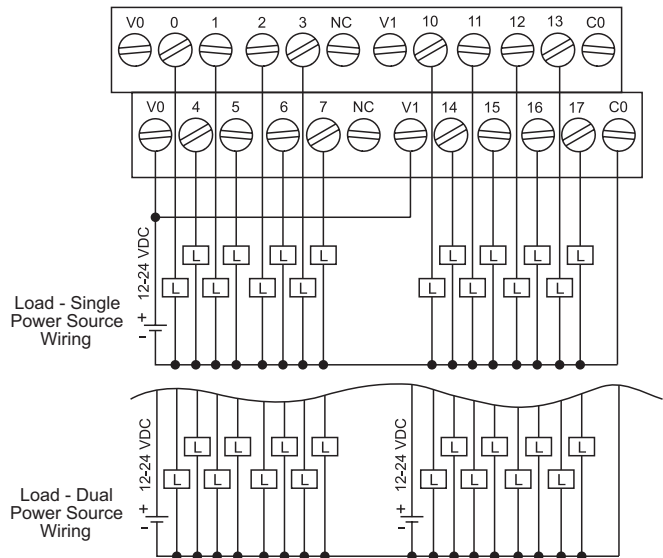

DL05/06 I/O Option Modules

D0-07CDR **\$64.00**

**4-point DC input and
3-point relay output module**

D0-07CDR Input Specifications	
Number of Inputs	4 (sink/source)
Input Voltage Range	10.8-26.4VDC
Peak Voltage	30VDC
Maximum Input Current	11mA @ 26.4VDC
Input Current	Typical: 4mA @ 12VDC 8.5mA @ 24VDC
Input Impedance	2.8K @ 12-24VDC
ON Voltage Level	> 10.0VDC
OFF Voltage Level	< 2.0VDC
Minimum ON Current	3.5ms
Maximum OFF Current	0.5ms
ON to OFF Response	2-8ms, Typical 4ms
OFF to ON Response	2-8ms, Typical 4ms
Commons	1 (4 points/common)

D0-07CDR Output Specifications	
Number of Outputs	3
Output Voltage Range	6-27VDC/6-240VAC
Output Type	Relay, form A (SPST)
Peak Voltage	30.0VDC/264VAC
Maximum Current (resist.)	1A/point, 4A/common
Minimum Load Current	5mA @ 5VDC
Maximum Leakage Current	0.1mA @ 264VAC
On Voltage Drop	N/A
Maximum Inrush Current	Output: 3A for 10ms Common: 10A for 10ms
Off to On Response	< 15ms
On to Off Response	< 10ms
Status Indicators	Module activity: one green LED
Commons	1 (3 points/common)
Fuse	No fuse
Terminal Type (Included)	Removable: D0-ACC-4
Base Power Required (5V)	Max. 200mA (all pts. on)



See Wiring Solutions for part numbers of ZIP Link cables and connection modules compatible with this I/O module.

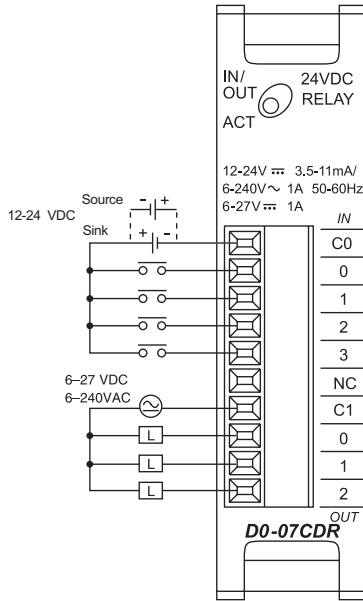

Equivalent input circuit

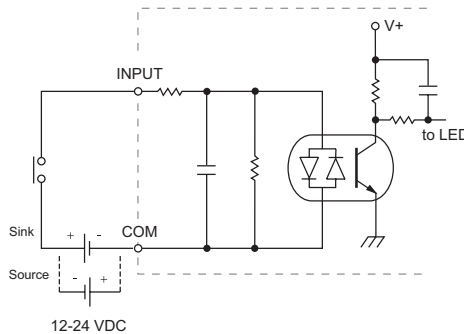

For "Sinking and Sourcing Concepts", see the Appendix section in this catalog.

Equivalent output circuit

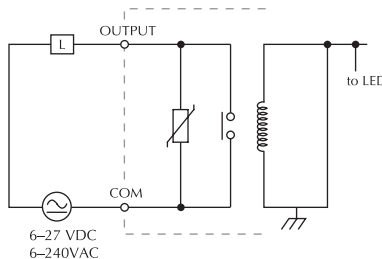

Derating chart for DC inputs

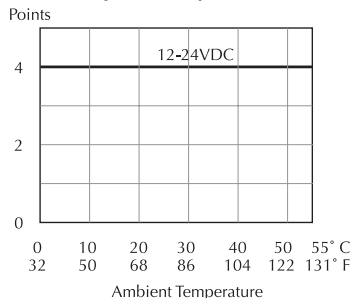

Derating chart for relay outputs

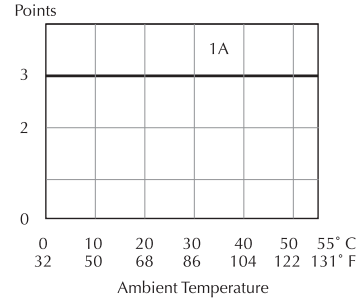

DL05/06 I/O Option Modules

DO-08TR **\$64.00**

8-point relay output module

DO-08TR Output Specifications	
Number of Outputs	8
Output Voltage Range	6-27VDC/6-240VAC
Output Type	Relay, form A (SPST)
Peak Voltage	30.0VDC/264VAC
Maximum Current (resist.)	1A/point, 4A/common
Minimum Load Current	5mA @ 5VDC
Maximum Leakage Current	0.1mA @ 264VAC
On Voltage Drop	N/A
Maximum Inrush Current	Output: 3A for 10ms Common: 10A for 10ms
Off to On Response	< 15ms
On to Off Response	< 10ms
Status Indicators	Module activity: one green LED
Commons	2 isolated (4 points/common)
Fuse	No fuse
Terminal Type (Included)	Removable: DO-ACC-4
Base Power Required (5V)	Max. 280mA (all pts. on)

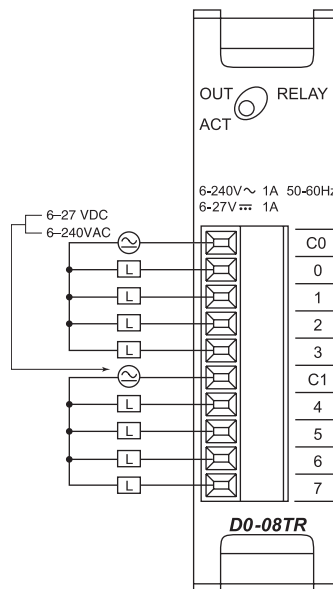

See Wiring Solutions for part numbers of ZIPLink cables and connection modules compatible with this I/O module.

Note: When used with the ZIPLink wiring system, relay outputs are derated not to exceed 2 Amps per point max.

Derating chart

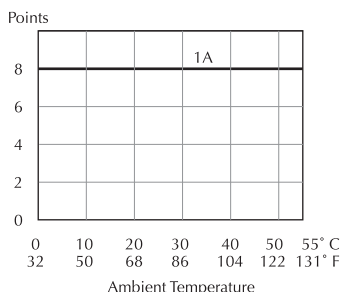

Equivalent output circuit

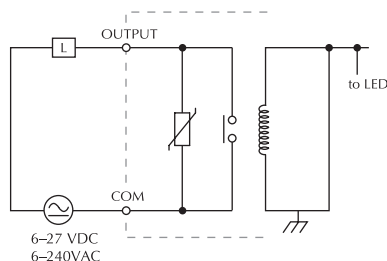

Typical Relay Life (Operations) at Room Temperature	
Voltage and Type of Load	Load Current 1A
24 VDC Resistive	500K
24 VDC Solenoid	100K
110 VAC Resistive	500K
110 VAC Solenoid	200K
220 VAC Resistive	350K
220 VAC Solenoid	100K

DL05/06 I/O Option Modules

F0-04TRS \$41.00

4-point relay output module

F0-04TRS Output Specifications	
Number of Outputs	4
Output Voltage Range	5-30VDC/5-125VAC
Output Type	2 - form C (SPDT) 2 - form A (SPST normally open)
Output Points Consumed	8
Peak Voltage	60VDC/220VAC
AC Frequency	47-63Hz
Maximum Current	3A per point, General Use*
Minimum Load Current	10mA @ 5V
Maximum Leakage Current	N/A
ON Voltage Drop	N/A
Maximum Inrush Current	3A
Off to On Response	≤ 5mS (typical)
On to Off Response	≤ 5mS (typical)
Status Indicators	None
Commons	4 isolated
Fuses	4, IEC 3.15A, replaceable, D2-FUSE-1
Terminal Type (Included)	Removable: D0-ACC-4
Base Power Required (5V)	250mA Max. (all points ON)

* Using the ZIPLink wiring system will derate this module to 2 Amps per point.

F0-04TRS Typical Relay Life at 30 Operations per Minute			
Load Type	Rated Voltage	Rated Current	Number of Operations
Resistive	120VAC	3A	120,000
Resistive	120VAC	1A	550,000
Resistive	24VDC	1A	>2M
Inductive: SC-E5 Motor Starter	120VAC	0.1A operating 1.7A fault	>2M (see Note)

Note: Transient suppression must be installed with inductive loads (Ex: P6KE150CA).

CPU	Firmware Required	DirectSOFT Required
DL05	Version 4.70 or later	Version 3.0c or later
DL06	Version 1.50 or later	Version 4.0, Build 16 or later



See Wiring Solutions for part numbers of ZIPLink cables and connection modules compatible with this I/O module.

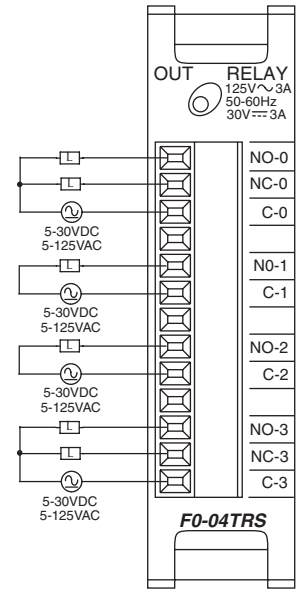

Typical Circuit

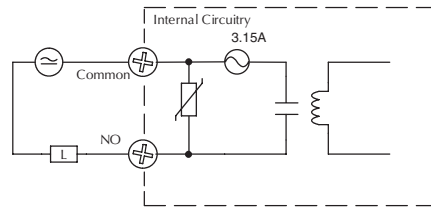

Typical Circuit

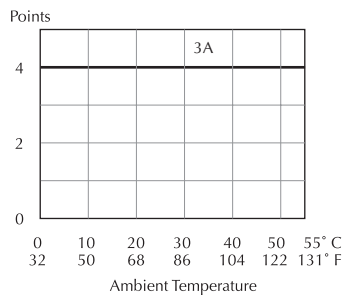
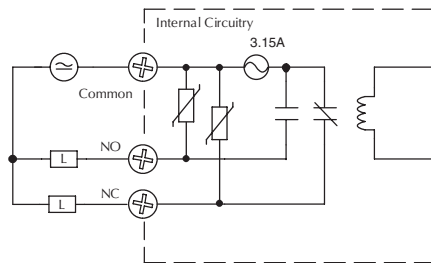

DL05/06 I/O Option Modules

D0-08CDD1 \$64.00

**4-point DC input and
4-point DC output module**

D0-08CDD1 Input Specifications	
Number of Inputs	4 (sink/source)
Input Voltage Range	10.8-26.4VDC
Peak Voltage	30.0VDC
Input Current	Typical: 4.0mA @ 12VDC 8.5mA @ 24VDC
Maximum Input Current	11mA @ 26.4VDC
Input Impedance	2.8KΩ @ 12-24VDC
On Voltage Level	> 10.0 VDC
Off Voltage Level	< 2.0 VDC
Minimum ON Current	3.5mA
Maximum OFF Current	0.5mA
Off to On Response	2-8ms, Typ. 4ms
On to Off Response	2-8ms, Typ. 4ms
Commons	1(4 pts/common) non-isolated

D0-08CDD1 Output Specifications	
Number of Outputs	4 (sinking)
Operating Voltage Range	6-27VDC
Output Voltage Range	5-30VDC
Peak Voltage	50.0VDC
Maximum Output Current	0.3A/point, 1.2A/common
Minimum Output Current	0.5mA
Maximum Leakage Current	1.5μA @ 30.0VDC
On Voltage Drop	0.5VDC @ 0.3A
Maximum Inrush Current	1A for 10ms
Off to On Response	< 10μs
On to Off Response	< 60μs
Status Indicators	Module activity: one green LED
Commons	1(4 pts/common) non-isolated
Fuse	No fuse
Terminal Type (Included)	Removable: D0-ACC-4
Base Power Required (5V)	Max. 200mA (all pts. on)
External DC Power Required (24V)	20-28VDC, max. 80mA (all pts. on)



See Wiring Solutions for part numbers of ZIP Link cables and connection modules compatible with this I/O module.

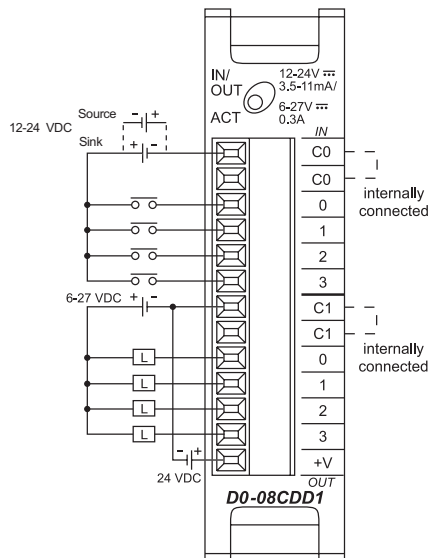

Equivalent input circuit

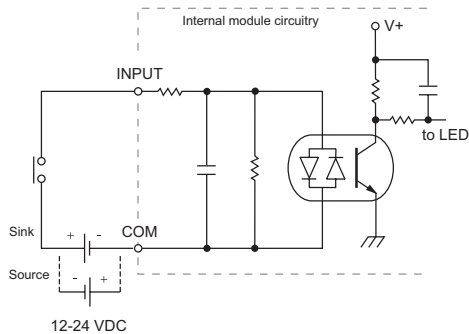

For "Sinking and Sourcing Concepts", see the Appendix section in this catalog.

Equivalent output circuit

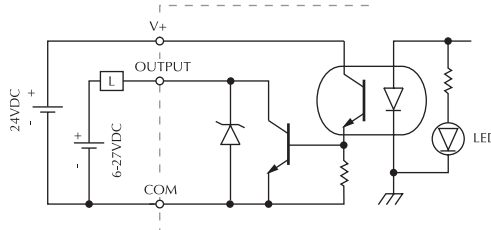

Derating chart for DC inputs

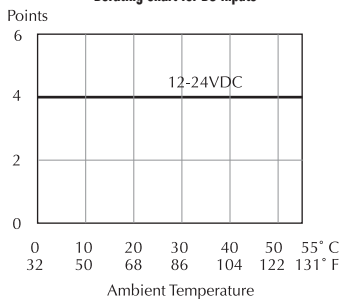

Derating chart for DC outputs

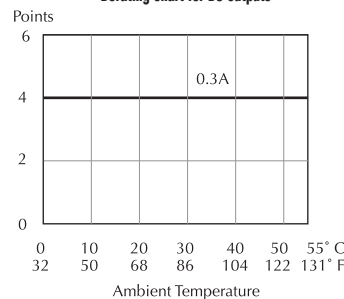

DL05/06 Option Modules

F0-04AD-1 \$83.00

4-channel analog current input module

F0-04AD-1 Input Specifications	
Number of Channels	4, single ended (one common)
Input Range	0 to 20mA or 4 to 20mA (jumper selectable)
Resolution	12 bit (1 in 4096)
Step Response	25.0mS (typ.) to 95% of full step change
Crosstalk	1/2 count max (-80db)*
Active Low-pass Filtering	-3dB at 40Hz (-12dB per octave)
Input Impedance	125Ω ± 0.1%, 1/8 watt
Absolute Max Ratings	-30mA to +30mA, current input
Converter Type	Successive approximation
Linearity Error (end to end)	± 2 counts
Input Stability	± 1 count*
Full-scale Calibration Error	± 10 counts max. @ 20mA*
Offset Calibration Error	± 5 counts max. @ 4mA*
Max Inaccuracy	± 0.4% at 25°C (77°F) ± 0.85% at 0 to 60°C (32 to 140°F)
Accuracy vs. Temperature	± 100 ppm/°C typical
Terminal Type (Included)	Removable: F0-IOCON
Recommended Fuse	0.032A, series 217 fast-acting, current inputs

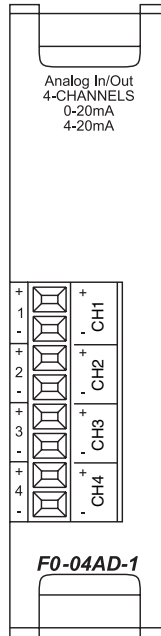

See Wiring Solutions for part numbers of ZIPLink cables and connection modules compatible with this I/O module.

* One count in the specification table is equal to one least significant bit of the analog data value (1 in 4096)

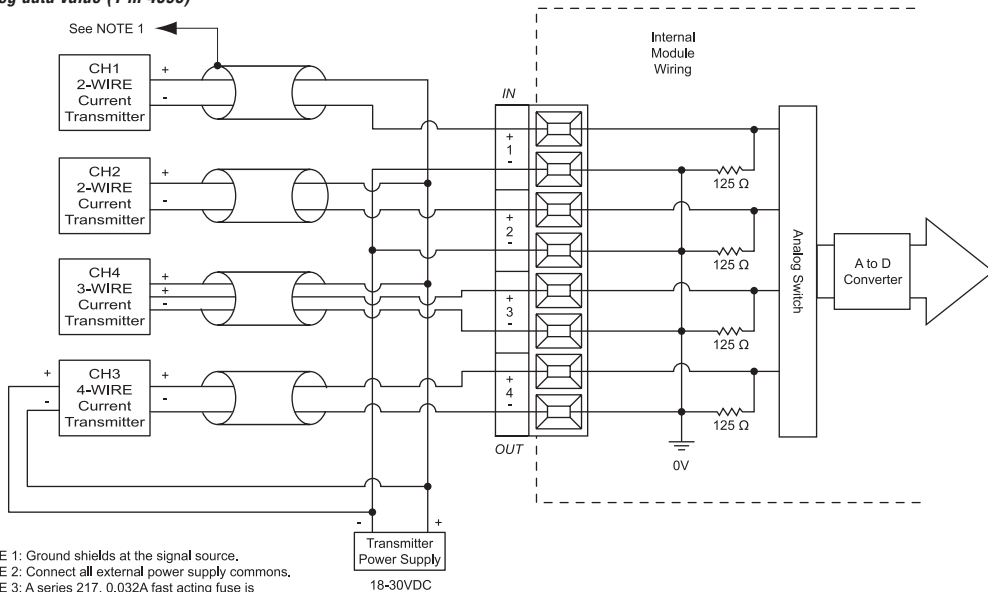

DL05/06 I/O Option Modules

F0-04AD-2 \$120.00

4-channel analog voltage input module

F0-04AD-2 Input Specifications	
Number of Channels	4, single ended (one common)
Input Range	0 to 5VDC or 0 to 10VDC (jumper selectable)
Resolution	12 bit (1 in 4096)
Step Response	10.0mS to 95% of full step change
Crosstalk	1/2 count max (-80db)*
Active Low-pass Filtering	-3dB at 300Hz (-12dB per octave)
Input Impedance	>20KΩ
Absolute Max Ratings	±15V
Linearity Error (end to end)	±2 count (0.025% of full scale) max*
Input Stability	±1 count*
Gain Error	±6 counts max*
Offset Error	±2 counts max*
Terminal Type (Included)	Removable: F0-IOCON
Max Inaccuracy	±0.3% at 25°C (77°F) ±0.6% at 0 to 60°C (32 to 140°F)
Accuracy vs. Temperature	±100 ppm/°C typical

CPU	Firmware Required	DirectSOFT32 Required
DL05	Version 4.60 or later	Version 3.0c or later
DL06	Version 1.40 or later	Version 4.0, Build 16 or later



See Wiring Solutions for part numbers of ZIPLink cables and connection modules compatible with this I/O module.

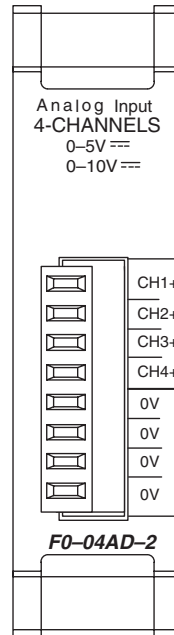

* One count in the specification table is equal to one least significant bit of the analog data value (1 in 4096)

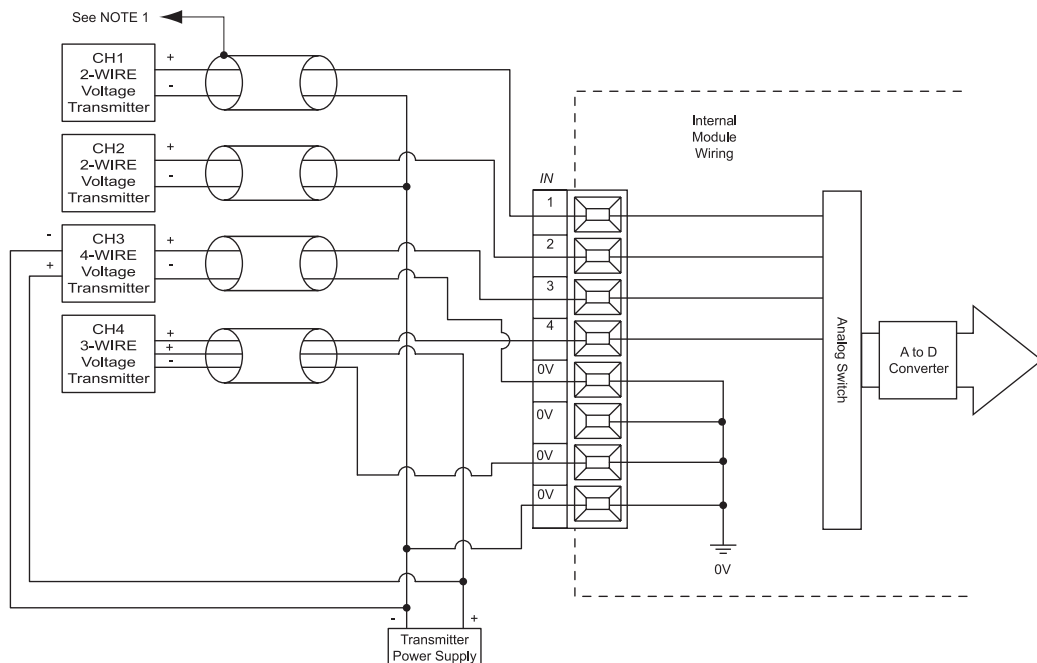

NOTE 1: Ground shields at the signal source.
NOTE 2: Connect all external power supply commons.

DL05/06 Option Modules

F0-08ADH-1 **\$134.00**

8-channel analog current input module, high resolution

Input Specifications	
Number of Channels	8
Input Range	0-20mA
Resolution	16-bit, .305µA/bit
Input Type	Single Ended (one common)
Maximum Cont. Overload	±31mA
Input Impedance	100 ohms, 1/10W, current input
Filter Characteristics	Low pass, -3dB @ 60Hz
PLC Data Format	16-bit, Unsigned Int., 0-FFFF (binary) or 0-65535 (BCD) (Both require 2 words of V-memory)
Sample Duration Time	10.2ms (time to 95% of full step change / channel)
All Channel Update Rate	81.6ms
Open Circuit Detection Time	Zero reading within 1s
Conversion Method	Successive Approximation
Accuracy vs. Temperature	±50PPM/°C Max.
Maximum Inaccuracy	0.2% of range (including temp. changes)
Linearity Error (End to End)	±10 count max.; Monotonic with no missing codes
Input Stability and Repeatability	±10 count max.
Full Scale Calibration Error	±10 count max.
Offset Calibration Error	±10 count max.
Maximum Crosstalk at DC, 50 Hz and 60 Hz	±10 count max.
External 24VDC Power Required	25mA
Base Power Required (5.0V)	25mA
Terminal Type (Included)	Removable: D0-ACC-4
Recommended Fuse	Littelfuse Series 217, .032A fuse

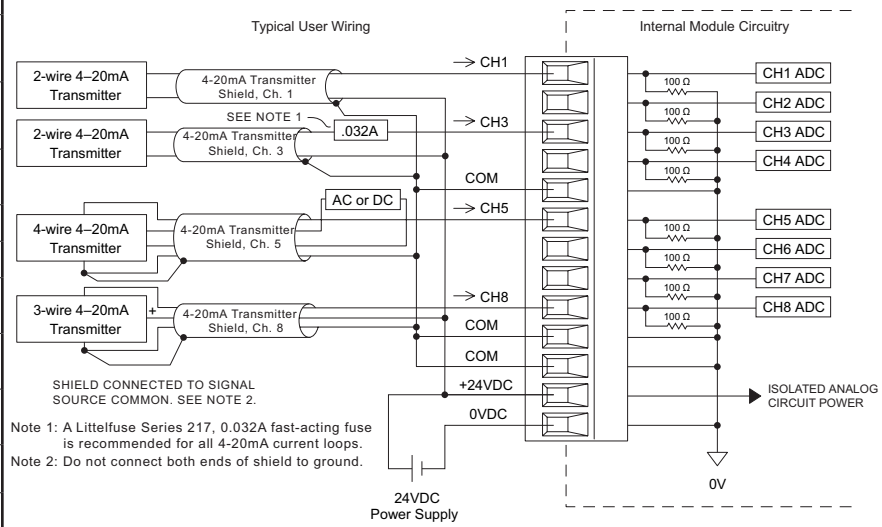
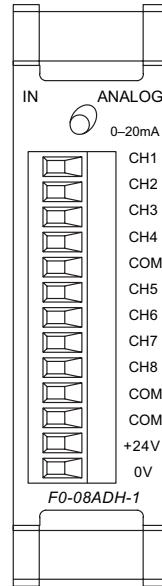

CPU	Firmware Required	DirectSOFT Required
DL05	Version 5.20 or later	DirectSOFT32 Version 3.0c or later
DL06	Version 2.30 or later	DirectSOFT32 Version 4.0, Build 16 or later



See Wiring Solutions for part numbers of ZIPLink cables and connection modules compatible with this I/O module.

DL05/06 I/O Option Modules

F0-08ADH-2 **\$144.00**

8-channel analog voltage input module, high resolution

Input Specifications	
Number of Channels	8
Input Range	0-5VDC or 0-10VDC (Jumper select)
Resolution	16-bit, 76µV/bit or 152µV/bit
Input Type	Single Ended (one common)
Maximum Cont. Overload	±100V
Input Impedance	>200k ohms
Filter Characteristics	Low pass, -3dB @ 60Hz
PLC Data Format	16-bit, Unsigned Int., 0-FFFF (binary) or 0-65535 (BCD) (Both require 2 words of V-memory)
Sample Duration Time	10.2 ms
All Channel Update Rate	81.6 ms
Conversion Method	Successive Approximation
Accuracy vs. Temperature	±50PPM / °C Maximum
Maximum Inaccuracy	0.2% of range (including temp. drift)
Linearity Error (End to End)	±10 count max. Monotonic with no missing codes
Input Stability and Repeatability	±10 count (after 10 min. warm up)
Full Scale Calibration Error (including Offset)	±10 counts max.
Offset Calibration Error	±10 count max.
Maximum Crosstalk at DC, 50 Hz and 60 Hz	±10 count max.
External 24VDC Power Required	25mA
Base Power Required (5.0V)	25mA

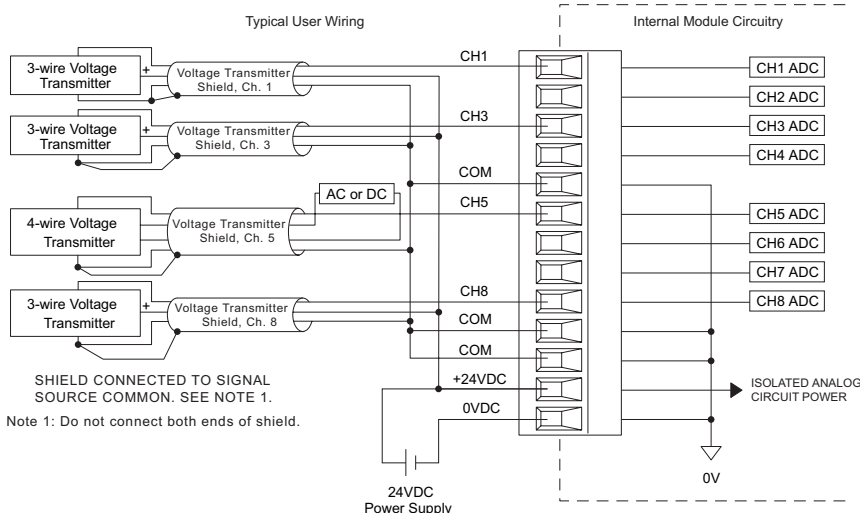
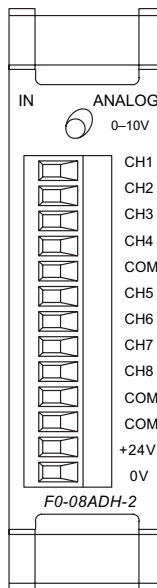

CPU	Firmware Required	DirectSOFT Required
DL05	Version 5.20 or later	DirectSOFT32 Version 3.0c or later
DL06	Version 2.30 or later	DirectSOFT32 Version 4.0, Build 16 or later



See Wiring Solutions for part numbers of ZIPLink cables and connection modules compatible with this I/O module.

DL05/06 Option Modules

F0-04RTD **\$207.00**

4-channel RTD input module

F0-04RTD Input Specifications	
Number of Channels	4
Input Ranges	Type Pt100: -200.0/850.0°C, -328/1562°F Type Pt1000: -200.0/595.0°C, -328/1103°F Type jPt100: -38.0/450.0°C, -36/842°F Type CU-10/25: -200.0/260.0°C, -328/500°F Type NI-120: -80.0/260.0°C, -112/500°F
Resolution	16 bit (1 in 65535)
Display Resolution	±0.1°C, ±0.1°F (±3276.7)
RTD Excitation Current	200 µA
Notch Filter	> 50 db notches at 50/60 Hz
Maximum Setting Time	100 ms (full-scale step input)
Common Mode Range	0-5 VDC
Absolute Maximum Ratings	Fault protected inputs to ±50 VDC
Sampling Rate	140 ms per channel

F0-04RTD Input Specifications (cont'd)	
Terminal Type (included)	Removable: D0-ACC-4
Converter Type	Charge Balancing
Linearity Error	±0.05°C maximum, ±0.1°C typical
Maximum Inaccuracy	±1°C
PLC Update Rate	4 channel/scan
Digital Input Points Required	None; uses special V-memory location based on slot
Base Power Required 5VDC	70 mA
Operating Temperature	32° to 140°F (0° to 60°C)
Storage Temperature	-4° to 158°F (-20° to 70°C)
Temperature Drift	15 ppm / °C max
Relative Humidity	5 to 95% (non-condensing)
Environmental Air	No corrosive gases permitted
Vibration	MIL STD 810C 514.2
Shock	MIL STD 810C 516.2
Noise Immunity	NEMA ICS3-304

CPU	Firmware Required	DirectSOFT Required
DL05	Version 4.70 or later	DirectSOFT32 Version 3.0c or later
DL06	Version 1.50 or later	DirectSOFT32 Version 4.0, Build 16 or later

Notes:

1. The three wires connecting the RTD to the module must be the same type and length. Do not use the shield or drain wire for the third connection.
2. Unused channels require shorting wires (jumpers) installed from terminals CH+ to CH- to COM to prevent possible noise from influencing active channels. This should be done even if the unused channel is not enabled in the V-memory configuration.
3. If an RTD sensor has four wires, the plus sense wire should be left unconnected as shown.
4. This module is not compatible with the ZIPLink wiring system.

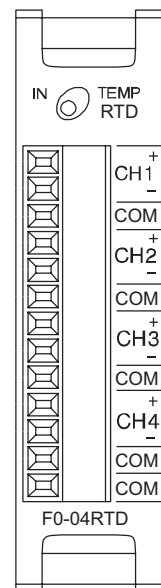
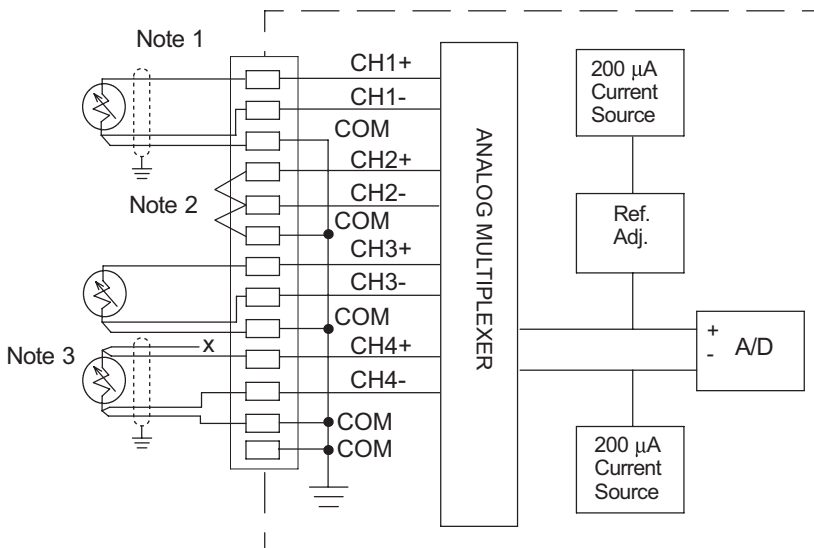

DL05/06 Option Modules

F0-04DAH-1 **\$144.00**

4-channel analog current output module, high resolution

Output Specifications	
Number of Channels	4
Output Range	4-20mA
Resolution	16-bit, .244µA/bit
Output Type	Current sourcing at 20mA max.
PLC Data Format	16-bit, Unsigned Int., 0-FFFF (binary) or 0-65535 (BCD) (Both require 2 words of V-memory)
Output value in program mode	4mA
Load Impedance	250-750 Ohms
Maximum Inductive Load	1 mH
Allowed load type	Grounded
Maximum Inaccuracy	0.2% of range
Maximum Full Scale Calibration Error (not including offset error)	±.025% of range max.
Maximum Offset Calibration Error	±.025% of range max.
Accuracy vs. Temperature	±50 ppm/ °C max. full scale calibration change
Maximum Crosstalk	±10 counts
Linearity Error (End to End)	±16 count maximum (±0.025% of full scale) Monotonic with no missing codes
Output Stability and Repeatability	±10 LSB after 10 min. warm-up typical
Output Ripple	.05% of Full Scale
Output Settling Time	.5 ms max., 5 µs min. (full scale change)
All Channel Update Rate	100µs
Maximum Continuous Overload	Outputs open circuit protected
Type of Output Protection	Electronically current limited to 20mA or less
Output signal at power-up and power-down	4mA
Terminal Type (Included)	Removable: D0-ACC-4
External 24VDC Power Required	150mA
Base Power Required (5.0V)	25mA

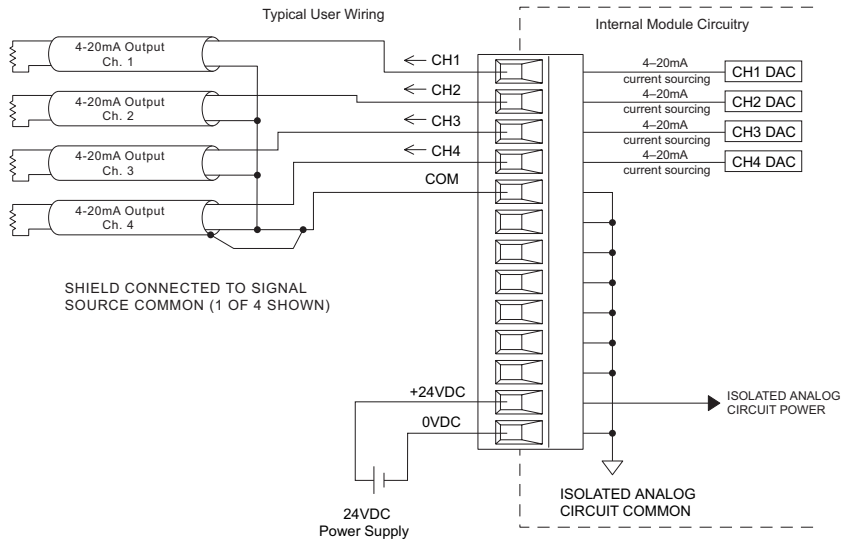
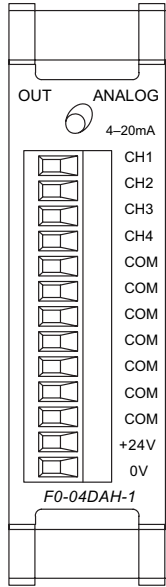

CPU	Firmware Required	DirectSOFT Required
DL05	Version 5.20 or later	DirectSOFT32 Version 3.0c or later
DL06	Version 2.30 or later	DirectSOFT32 Version 4.0, Build 16 or later



See Wiring Solutions for part numbers of ZIPLink cables and connection modules compatible with this I/O module.

- Company Information
- Control Systems Overview
- CLICK PLC
- Do-More PLCs Overview
- Do-More H2 PLC
- Do-More T1H PLC
- DirectLOGIC PLCs Overview
- DirectLOGIC DL05/06
- DirectLOGIC DL105
- DirectLOGIC DL205
- DirectLOGIC DL305
- DirectLOGIC DL405
- Productivity Controller Overview
- Productivity 3000
- Universal Field I/O
- Software
- C-More HMI
- C-More Micro HMI
- ViewMarq Industrial Marquees
- Other HMI
- Communications
- Appendix Book 1
- Terms and Conditions

DL05/06 I/O Option Modules

F0-08DAH-1 **\$197.00**

8-channel analog current output module, high resolution

Output Specifications	
Number of Channels	8
Output Range	4-20mA
Resolution	16-bit, .244µA/bit
Output Type	Current sourcing at 20mA max.
PLC Data Format	16-bit, Unsigned Int., 0-FFFF (binary) or 0-65535 (BCD) (Both require 2 words of V-memory)
Output value in program mode	4mA
Load Impedance	250-750 Ohms
Maximum Inductive Load	1 mH
Allowed load type	Grounded
Maximum Inaccuracy	0.2% of range
Maximum Full Scale Calibration Error (not including offset error)	±.025% of range maximum
Maximum Offset Calibration Error	±.025% of range maximum
Accuracy vs. Temperature	±50 ppm/ °C maximum full scale calibration change
Maximum Crosstalk	±10 counts
Linearity Error (End to End)	±16 count maximum (±0.025% of full scale) Monotonic with no missing codes
Output Stability and Repeatability	±10 counts after 10 min. warm-up typical
Output Ripple	.05% of Full Scale
Output Settling Time	.5 ms max., 5 µs min. (full scale change)
All Channel Update Rate	100µs
Maximum Continuous Overload	Outputs open circuit protected
Type of Output Protection	Electronically current limited to 20mA or less
Output signal at power-up and power-down	4mA
Terminal Type (Included)	Removable: D0-ACC-4
External 24VDC Power Required	220mA
Base Power Required (5.0V)	25mA

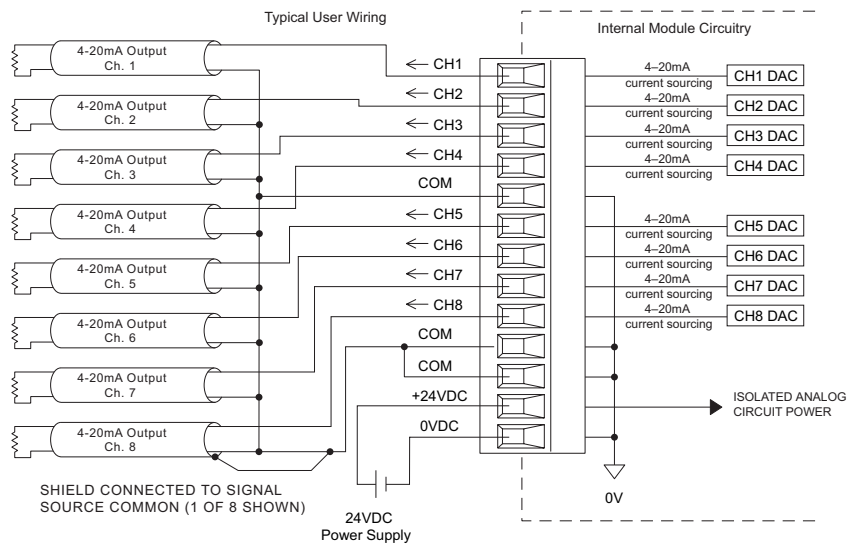
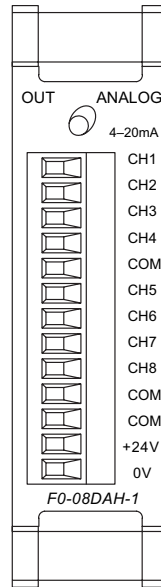

CPU	Firmware Required	DirectSOFT Required
DL05	Version 5.20 or later	DirectSOFT32 Version 3.0c or later
DL06	Version 2.30 or later	DirectSOFT32 Version 4.0, Build 16 or later



See Wiring Solutions for part numbers of ZIPLink cables and connection modules compatible with this I/O module.

DL05/06 Option Modules

F0-04DAH-2 \$140.00

4-channel analog voltage output module, high resolution

Output Specifications	
Number of Channels	4
Output Range	0-10VDC
Resolution	16-bit, 152µV/bit
Output Type	Voltage sourcing/sinking at 5mA max.
PLC Data Format	16-bit, Unsigned Int., 0-FFFF (binary) or 0-65535 (BCD) (Both require 2 words of V-memory)
Output value in program mode	0V
Output Impedance	0.5 Ohms typical
Load Impedance	>2000 Ohms
Maximum Capacitive Load	0.01 µF maximum
Allowed load type	Grounded
Maximum Inaccuracy	0.2% of range (including temperature changes)
Maximum Full Scale Calibration Error (including offset error)	±.025% of range max.
Maximum Offset Calibration Error	±.025% of range max.
Accuracy vs. Temperature	±50 ppm/ °C max. full scale calibration change
Maximum Crosstalk	±10 counts
Linearity Error (End to End)	±16 count max. (±0.025% of full scale) Monotonic with no missing codes
Output Stability and Repeatability	±10 counts after 10 min. warm-up typical
Output Ripple	.05% of Full Scale
Output Settling Time	5 ms max., 5 µs min. (full scale change)
All Channel Update Rate	100µs
Maximum Continuous Overload	Outputs current limited to 40mA typical. A continuous short circuit will damage the output.
Type of Output Protection	24VDC Peak Output Voltage (capacitor transient voltage suppressor)
Output signal at power-up and power-down	0V
Terminal Type (Included)	Removable: D0-ACC-4
External 24VDC Power Required	30mA
Base Power Required (5.0V)	25mA

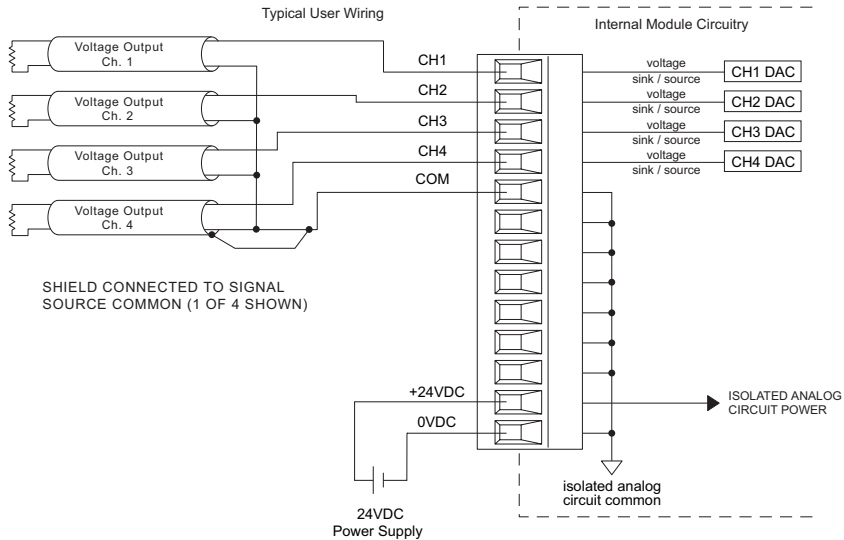
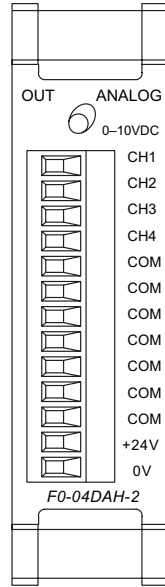

CPU	Firmware Required	DirectSOFT Required
DL05	Version 5.20 or later	DirectSOFT32 Version 3.0c or later
DL06	Version 2.30 or later	DirectSOFT32 Version 4.0, Build 16 or later

See Wiring Solutions for part numbers of ZIPLink cables and connection modules compatible with this I/O module.

Company Information

Control Systems Overview

CLICK PLC

Do-More PLCs Overview

Do-More H2 PLC

Do-More T1H PLC

DirectLOGIC PLCs Overview

DirectLOGIC DL05/06

DirectLOGIC DL105

DirectLOGIC DL205

DirectLOGIC DL305

DirectLOGIC DL405

Productivity Controller Overview

Productivity 3000

Universal Field I/O

Software

C-More HMI

C-More Micro HMI

ViewMarq Industrial Marquees

Other HMI

Communications

Appendix Book 1

Terms and Conditions

DL05/06 I/O Option Modules

F0-08DAH-2 **\$186.00**

8-channel analog voltage output module, high resolution

Output Specifications	
Number of Channels	8
Output Range	0-10VDC
Resolution	16-bit, 152µV/bit
Output Type	Voltage sourcing/sinking at 5mA max.
PLC Data Format	16-bit, Unsigned Int., 0-FFFF (binary) or 0-65535 (BCD) (Both require 2 words of V-memory)
Output value in program mode	0V
Output Impedance	0.5 Ohms typical
Load Impedance	>2000 Ohms
Maximum Capacitive Load	0.01 µF maximum
Allowed load type	Grounded
Maximum Inaccuracy	0.2% of range (including temperature changes)
Maximum Full Scale Calibration Error (including offset error)	±.025% of range maximum
Maximum Offset Calibration Error	±.025% of range maximum
Accuracy vs. Temperature	±50 ppm/ °C maximum full scale calibration change
Maximum Crosstalk	10 counts
Linearity Error (End to End)	±16 count maximum (±0.025% of full scale) Monotonic with no missing codes
Output Stability and Repeatability	±10 counts after 10 min. warm-up typical
Output Ripple	.05% of Full Scale
Output Settling Time	.5 ms max., 5 µs min. (full scale change)
All Channel Update Rate	100µs
Maximum Continuous Overload	Outputs current limited to 40mA typical. A continuous short circuit will damage the output.
Type of Output Protection	24VDC Peak Output Voltage (capacitor transient voltage suppressor)
Output signal at power-up and power-down	0V
Terminal Type (Included)	Removable: D0-ACC-4
External 24VDC Power Required	30mA
Base Power Required (5.0V)	25mA

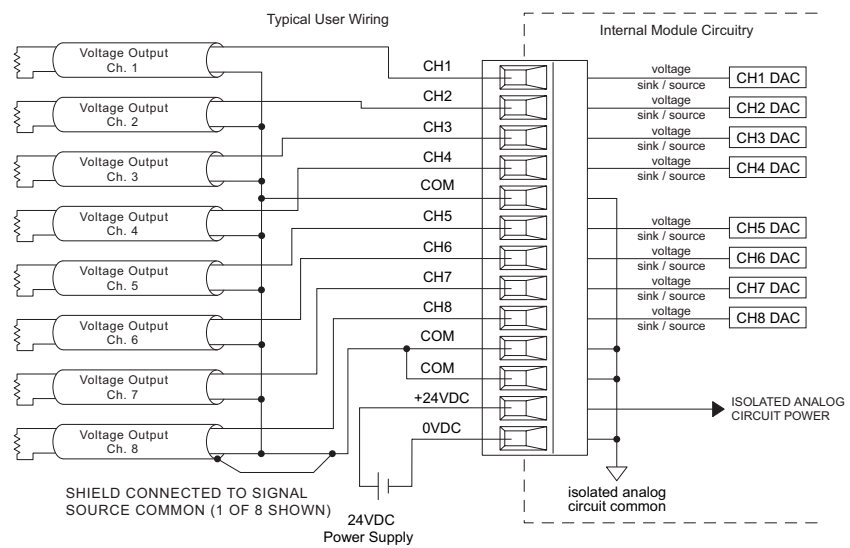
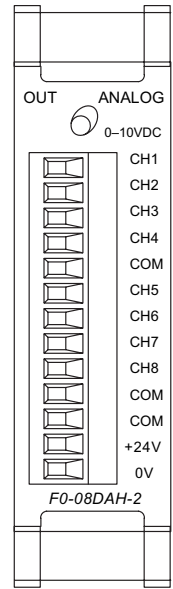

CPU	Firmware Required	DirectSOFT Required
DL05	Version 5.20 or later	DirectSOFT32 Version 3.0c or later
DL06	Version 2.30 or later	DirectSOFT32 Version 4.0, Build 16 or later

See Wiring Solutions for part numbers of ZIPLink cables and connection modules compatible with this I/O module.

DL05/06 Option Modules

F0-2AD2DA-2 **\$155.00**

**2-channel analog voltage input and
2-channel analog voltage output module**

F0-2AD2DA-2 Input Specifications	
Number of Channels	2, single ended (one common)
Input Range	0 to 5VDC or 0 to 10VDC (jumper selectable)
Resolution	12 bit (1 in 4096)
Step Response	10.0mS to 95% of full step change
Crosstalk	1/2 count max (-80db)*
Active Low-pass Filtering	-3dB at 300Hz (-12dB per octave)
Input Impedance	>20KΩ
Absolute Max Ratings	±15V
Linearity Error (end to end)	±2 counts (0.025% of full scale) max*
Input Stability	±1 count*
Gain Error	±6 counts max*
Offset Error	±2 counts max*
Max Inaccuracy	±0.3% at 25°C (77°F) ±0.6% at 0 to 60°C (32 to 140°F)
Accuracy vs. Temperature	±100 ppm/°C typical

F0-2AD2DA-2 Output Specifications	
Number of Channels	2, single ended (one common)
Output Range	0 to 5VDC or 0 to 10VDC (jumper selectable)
Resolution	12 bit (1 in 4096)
Conversion Settling Time	50μS for full scale change
Crosstalk	1/2 count max (-80db)*
Peak Output Voltage	±15VDC (power supply limited)
Offset Error	0.1% of range
Gain Error	0.4% of range
Linearity Error (end to end)	±1 counts (0.075% of full scale) max*
Output Stability	±2 counts*
Load Impedance	2KΩ min
Load Capacitance	0.01μF max
Terminal Type (Included)	Removable: F0-IOCON
Accuracy vs. Temperature	±50 ppm/°C typical

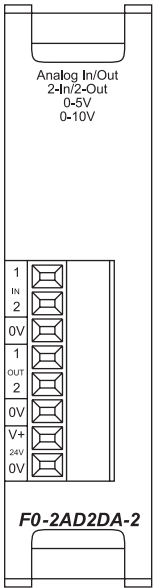

* One count in the specification table is equal to one least significant bit of the analog data value (1 in 4096)



See Wiring Solutions for part numbers of ZIP Link cables and connection modules compatible with this I/O module.

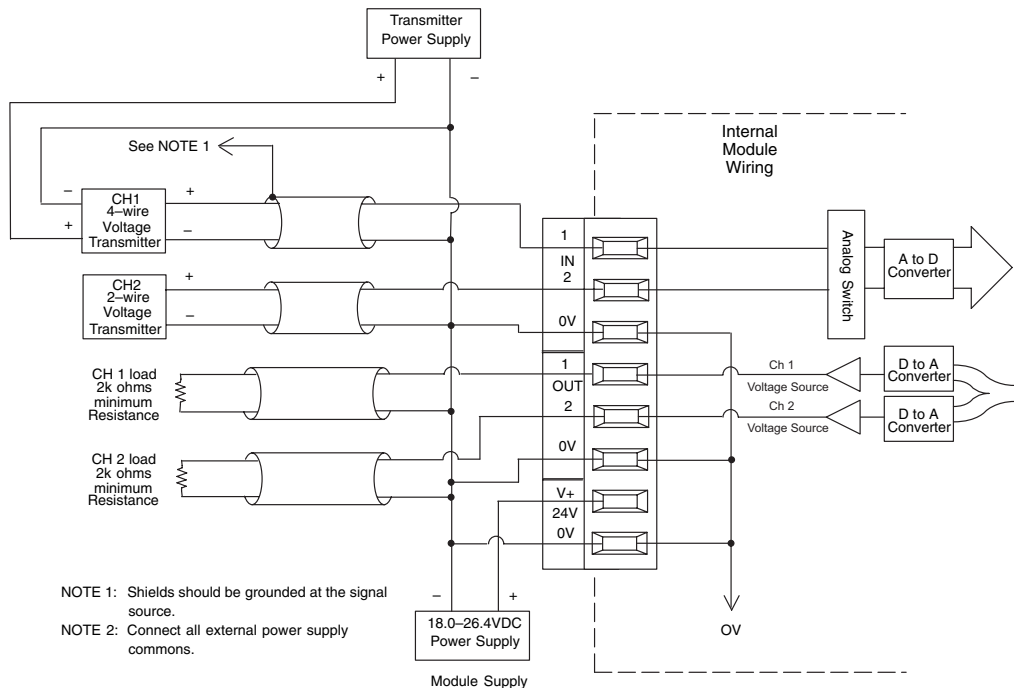

NOTE 1: Shields should be grounded at the signal source.
NOTE 2: Connect all external power supply commons.

- Company Information
- Control Systems Overview
- CLICK PLC
- Do-More PLCs Overview
- Do-More H2 PLC
- Do-More T1H PLC
- DirectLOGIC PLCs Overview
- DirectLOGIC DL05/06
- DirectLOGIC DL105
- DirectLOGIC DL205
- DirectLOGIC DL305
- DirectLOGIC DL405
- Productivity Controller Overview
- Productivity 3000
- Universal Field I/O
- Software
- C-More HMI
- C-More Micro HMI
- ViewMarq Industrial Marquees
- Other HMI
- Communications
- Appendix Book 1
- Terms and Conditions

DL05/06 Option Modules

F0-4AD2DA-1 \$192.00

4-channel analog current input and 2-channel analog current output module

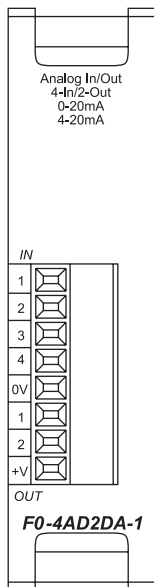

See Wiring Solutions for part numbers of ZIPLink cables and connection modules compatible with this I/O module.

F0-4AD2DA-1 Input Specifications	
Number of Channels	4, single ended (one common)
Input Range	0 to 20 mA or 4 to 20 mA (jumper selectable)
Resolution	12 bit (1 in 4096)
Step Response	25.0 mS (typ.) to 95% of full step change
Crosstalk	1/2 count max (-80db)*
Active Low-pass Filtering	-3 dB at 40 Hz (-12dB per octave)
Input Impedance	125 Ω ±0.1%, 1/8 watt
Absolute Max Ratings	-30mA to +30 mA, current input
Converter Type	Successive approximation
Linearity Error (end to end)	±2 counts
Input Stability	±1 count*
Full-scale Calibr. Error	±10 counts max. @ 20 mA*
Offset Calibration Error	±5 counts max. @ 0 mA*
Max Inaccuracy	±0.4% at 25°C (77°F) ±0.85% at 0 to 60°C (32 to 140°F)
Accuracy vs. Temp.	±100 ppm/°C typ.
Recommended Fuse	0.032 A, series 217 fast-acting, current inputs

F0-4AD2DA-1 Output Specifications	
Number of Channels	2, single ended (one common)
Output Range	0 to 20 mA or 4 to 20 mA (jumper selectable)
Output Type	Current sourcing
Resolution	12 bit (1 in 4096)
Max. Loop Voltage	30 VDC
Load/loop Power Supply	0-300 Ω /18-30 VDC
Linearity Error (end to end)	±2 counts (0.050% of full scale) max.*
Conversion Settling Time	400 μs max. for full scale change
Full-scale Calibration Error	±26 counts max. @ 300 Ω load ±18 counts max. @ 250 Ω load ±12 counts max. @ 125 Ω load
Offset Calibration Error	±10 counts max. @ 300 Ω load ±8 counts max. @ 250 Ω load ±6 counts max. @ 125 Ω load
Terminal Type (Included)	Removable: F0-IOCON
Max.Full- scale Inaccuracy (all errors included)	300 Ω load 0.4% @ 60° C 250 Ω load 0.3% @ 60° C 125 Ω load 0.2% @ 60° C

* One count in the specification table is equal to one least significant bit of the analog data value (1 in 4096)

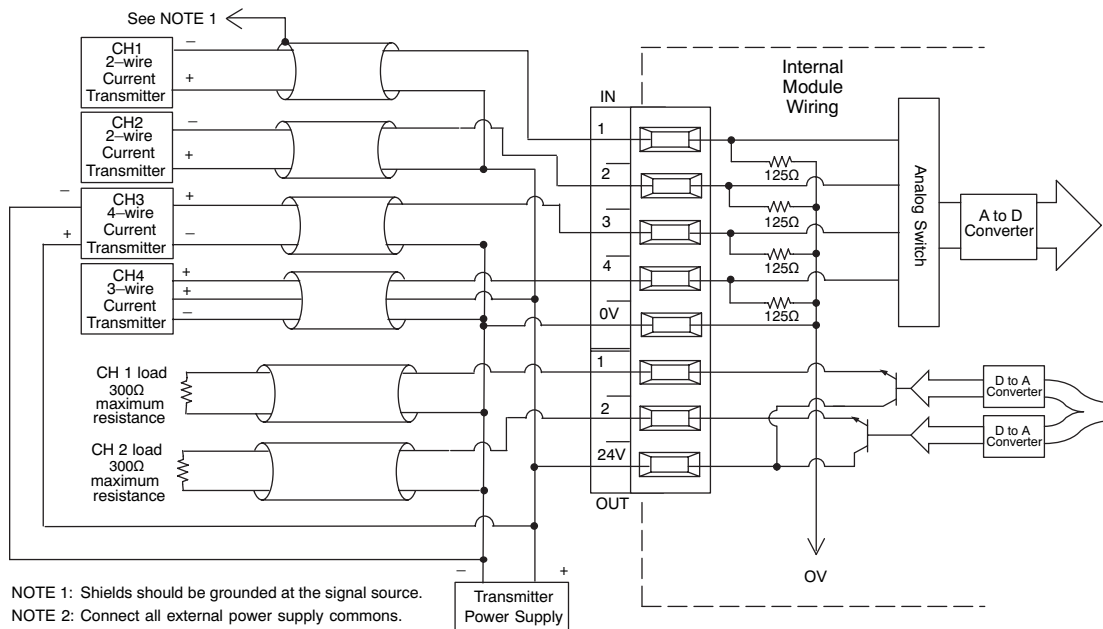

DL05/06 Option Modules

Company Information

Control Systems Overview

CLICK PLC

Do-More PLCs Overview

Do-More H2 PLC

Do-More T1H PLC

DirectLOGIC PLCs Overview

DirectLOGIC DL05/06

DirectLOGIC DL105

DirectLOGIC DL205

DirectLOGIC DL305

DirectLOGIC DL405

Productivity Controller Overview

Productivity 3000

Universal Field I/O

Software

C-More HMI

C-More Micro HMI

ViewMarq Industrial Marquees

Other HMI

Communications

Appendix Book 1

Terms and Conditions

F0-4AD2DA-2 \$218.00

4-channel analog voltage input
2-channel analog voltage output
module

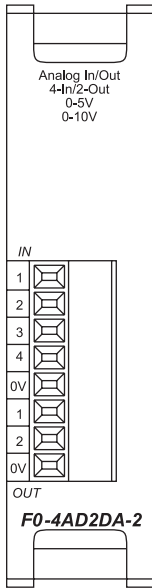

F0-4AD2DA-2 Input Specifications	
Number of Channels	4, single ended (one common)
Input Range	0 to 5VDC or 0 to 10VDC (jumper selectable)
Resolution	12 bit (1 in 4096)
Step Response	10.0mS to 95% of full step change
Crosstalk	1/2 count max (-80db)*
Active Low-pass Filtering	-3dB at 300Hz (-12dB per octave)
Input Impedance	>20KΩ
Absolute Max Ratings	±15V
Linearity Error (end to end)	±2 count (0.025% of full scale) max*
Input Stability	±1 count*
Gain Error	±6 counts max*
Offset Error	±2 counts max*
Max Inaccuracy	±0.3% at 25°C (77°F) ±0.6% at 0 to 60°C (32 to 140°F)
Accuracy vs. Temperature	±100 ppm/°C typical
Terminal Type (Included)	Removable: FO-IOCON

F0-4AD2DA-2 Output Specifications	
Number of Channels	2, single ended (one common)
Output Range	0 to 5VDC or 0 to 10VDC (jumper selectable)
Resolution	12 bit (1 in 4096)
Conversion Settling Time	50μS for full scale change
Crosstalk	1/2 count max (-80db)*
Peak Output Voltage	±15VDC (power supply limited)
Offset Error	0.1% of range
Gain Error	0.4% of range
Linearity Error (end to end)	±1 counts (0.075% of full scale) max*
Output Stability	±2 counts*
Load Impedance	2KΩ minimum
Load Capacitance	0.01μF max
Accuracy vs. Temperature	±50 ppm/°C typical



See Wiring Solutions for part numbers of ZIPLINK cables and connection modules compatible with this I/O module.

* One count in the specification table is equal to one least significant bit of the analog data value (1 in 4096)

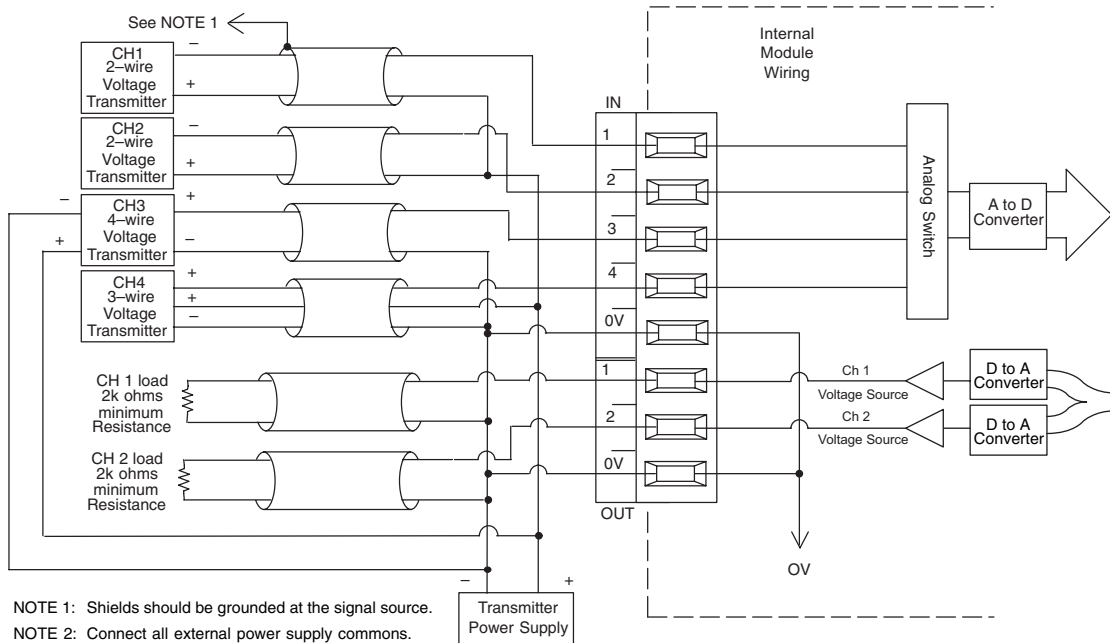

NOTE 1: Shields should be grounded at the signal source.
NOTE 2: Connect all external power supply commons.

Built-in High-Speed I/O Features

Overview

You can use the DL05 or DL06 PLCs to solve a diverse range of motion and high-speed machine control applications.

DC input and DC output versions of the DL05 and DL06 PLCs offer built-in high-speed input and pulse output features. On DL05 PLCs with DC inputs, the high-speed features are accessible on the first three input points (X0-X2). On DL06 PLCs with DC inputs, the high-speed features are accessible on the first four input points (X0-X3). On DL05 or DL06 PLCs with DC outputs, the pulse output feature is accessible on the first two output points (Y0-Y1).

Several modes of operation are available that meet the needs of many applications. The operating modes are explained in detail in the DL05 and DL06 PLC User Manuals. Only one high-speed I/O mode can be in use at one time. You cannot use a high-speed input feature and the pulse output feature at the same time. A brief description of each high-speed mode is listed below:

Mode 10 - High-speed counters offer 24 presets. When the preset is reached, an interrupt routine is executed (max. count: 99,999,999)

Mode 20 - Quadrature encoder input (up/down counter) for clockwise and counterclockwise position control (max count: 0 to 99,999,999 unipolar or -8,388,608 to 8,388,607 bipolar)

Mode 30 - Pulse outputs are programmable to follow a predetermined profile. An external interrupt can be used in conjunction with separate acceleration/deceleration profiles for positioning and velocity control (max. pulse range: -8,388,608 to 8,388,607)

Mode 40 - External interrupt inputs can be used for an immediate response to urgent application tasks

Mode 50 - The pulse catch input allows the CPU to read an input with a pulse width as narrow as 0.1 ms

Mode 60 - Input filters are configurable (0-99ms) to ensure input signal integrity. The default input mode is a 10ms filter

Mode 40 option - Timed interrupts can be configured for time critical events. Interrupt 0 can be scheduled on a 5ms-999ms cycle. Interrupt 1, available on the DL05, can be scheduled on a 5ms-9999ms cycle

DL05 High-speed I/O Features					
Mode*	DC Inputs Points			DC Output Points	
	X0	X1	X2	Y0	Y1
Mode 10: High-Speed Up Counter	Counter input	Filtered input	Reset count Filtered input	Regular output	Regular output
Mode 20: Quadrature Counter	Phase A input	Phase B input	Reset count Filtered input	Regular output	Regular output
Mode 40: High-Speed Interrupt	Interrupt input	Filtered input	Filtered input	Regular output	Regular output
Mode 50: Pulse Catch	Pulse input	Filtered input	Filtered input	Regular output	Regular output
Mode 30: Pulse Output	Filtered input	Filtered input	Positioning interrupt Filtered input	Pulse CW pulse	Direction CCW pulse
Mode 60: Filtered Input	Filtered input	Filtered input	Filtered input	Regular output	Regular output

DL06 High-speed I/O Features						
Mode*	DC Inputs Points				DC Output Points	
	X0	X1	X2	X3	Y0	Y1
Mode 10: High-Speed Up Counter	Counter Ch 1	Counter Ch 2 Interrupt Pulse input Filtered input	Reset Ch 1 Interrupt Pulse input Filtered input	Reset Ch 2 Interrupt Pulse input Filtered input	Regular output	Regular output
Mode 20: Up/Down Counter	Up input	Down input	Reset Pulse input Filtered input	Pulse input Filtered input	Regular output	Regular output
Mode 20: Quadrature Counter	Phase A input	Phase B input	Reset Pulse input Filtered input	Pulse input Filtered input	Regular output	Regular output
Mode 40: High-Speed Interrupt	Interrupt input	Interrupt Pulse input Filtered input	Interrupt Pulse input Filtered input	Interrupt Pulse input Filtered input	Regular output	Regular output
Mode 50: Pulse Catch	Pulse input	Interrupt Pulse input Filtered input	Interrupt Pulse input Filtered input	Interrupt Pulse input Filtered input	Regular output	Regular output
Mode 30: Pulse Output	Filtered input	Interrupt Pulse input Filtered input	Pulse input Filtered input	Pulse input Filtered input	Pulse CW Pulse	Direction CCW pulse
Mode 60: Filtered Input	Filtered input	Filtered input	Filtered input	Filtered input	Regular output	Regular output

*The high-speed input features cannot be used if the pulse output features are in use, and vice versa.

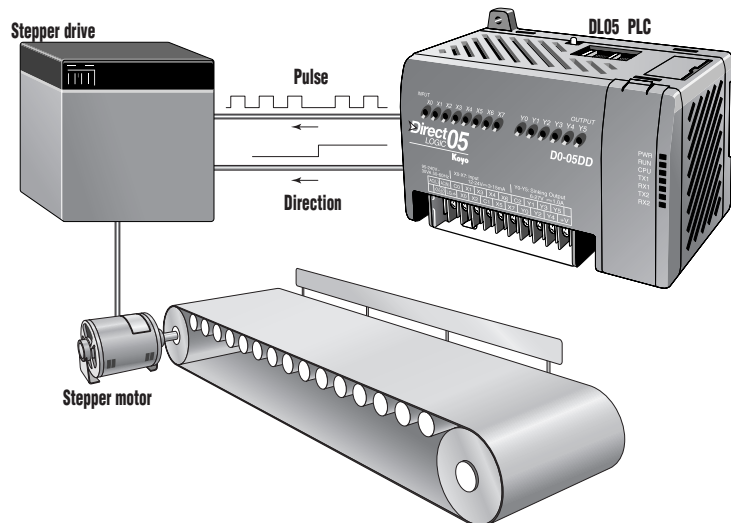

Built-in High Speed I/O Specifications

Company Information

Control Systems Overview

CLICK PLC

Do-More PLCs Overview

Do-More H2 PLC

Do-More T1H PLC

DirectLOGIC PLCs Overview

DirectLOGIC DL05/06

DirectLOGIC DL105

DirectLOGIC DL205

DirectLOGIC DL305

DirectLOGIC DL405

Productivity Controller Overview

Productivity 3000

Universal Field I/O

Software

C-More HMI

C-More Micro HMI

ViewMarq Industrial Marquees

Other HMI

Communications

Appendix Book 1

Terms and Conditions

High-Speed Input Specifications		
PLC	DL05	DL06
High-speed Inputs	3 pts. sink or source (X0-X2)	4 pts. sink or source (X0-X3)
Max. Input Frequency	5kHz	7kHz
Minimum Pulse Width	100 μ s	70 μ s
Input Voltage Range	12-24 VDC	
Input Impedance (hs only)	1.8K @ 12-24VDC	
ON Current/Voltage Level	>5mA/>10VDC	
OFF Current/Voltage Level	<0.5mA/<2VDC	
OFF to ON Response	<100 μ s	<70 μ s
ON to OFF Response	<100 μ s	<70 μ s

High-Speed Output Specifications		
PLC	DL05	DL06
Pulse Outputs	2 pts. (Y0 and Y1) current sinking	2 pts. (Y0 and Y1) current sinking or sourcing (sourcing outputs on DO-06DD2 only)
Max. Output Frequency	7kHz	10kHz
Voltage Range	6-27VDC	
Max. Load Current	0.5A/point	
ON Voltage Drop	0.3VDC @ 1.0A	
Leakage Current	15 μ A @ 30VDC	
Inrush Current	2A (100ms)	
OFF to ON Response	<10 μ s	<10 μ s
ON to OFF Response	<30 μ s	<20 μ s

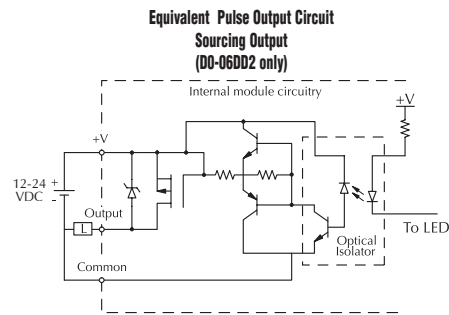
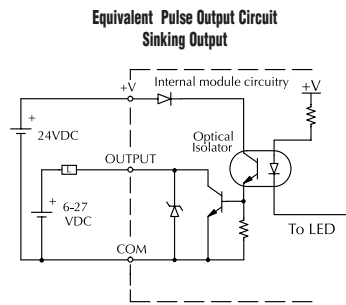
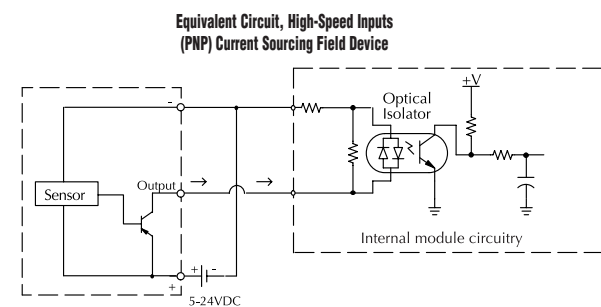
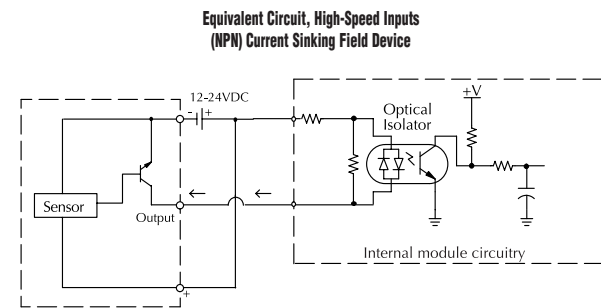
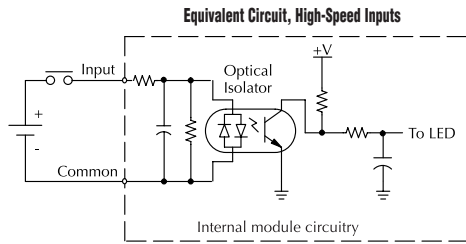
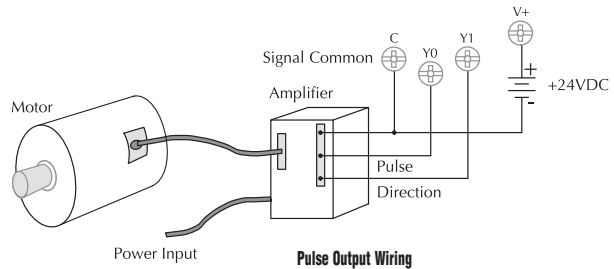
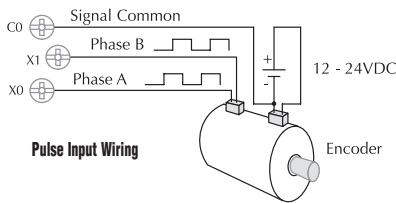

Timed Interrupt Feature

Time-based interrupts

There is a timed interrupt feature available in the DL05 and DL06 PLCs. This cyclical interrupt allows you to program a time-based interrupt that occurs on a scheduled basis. This feature is available in all units, regardless of input type.

The CPU's timed interrupt operates in a similar manner to the external interrupt input, but instead of the interrupt subroutine being triggered by an external event tied to X0, it is triggered by a cyclical interval of time. This interval can be programmed from 5 ms to 999 ms for INT0, which is available on either the DL05 or the DL06. The programmable time interval for INT1, which is available on the DL05, is 5 to 9999 ms.

Whenever the programmed time elapses, the CPU immediately suspends its routine scan cycle and jumps to the selected interrupt subroutine. As with the other modes, when the interrupt subroutine execution is complete, the CPU automatically resumes its routine scan cycle starting from the location where it was interrupted. Because the CPU scan time and the interrupt time interval are different, the point at which the RLL program is interrupted can change over time.

A note on timed interrupts

DL06: If you use the external hardware interrupt (mode 40), you cannot use the timed-based internal interrupt INT 0. You can use either one, but not both. This is because they share the same interrupt routine, INT 0.

DL05: The DL05 offers a second timed-based interrupt INT 1. This allows you to use an external hardware interrupt and/or a timed-based interrupt.

DL05 time-based interrupt

DL05 Designated Terminals

X0:..... Filtered input (uses filter time set for X1)

Timed Interrupt Specifications

Timed interrupts.....2 (internal to CPU)

Interrupt Subroutine.....INT0, INT1

Time interval:.....

INT05 to 999 ms (1 ms increments)

INT15 to 9999 ms (1 ms increments)

DL06 time-based interrupt

DL06 Designated Terminals

X0:..... Filtered input (uses filter time set for X1)

Timed Interrupt Specifications

Timed interrupts.....1 (internal to CPU)

Interrupt subroutine.....INT0

Time interval:.....

INT05 to 999 ms (1 ms increments)

Timed interrupt operation

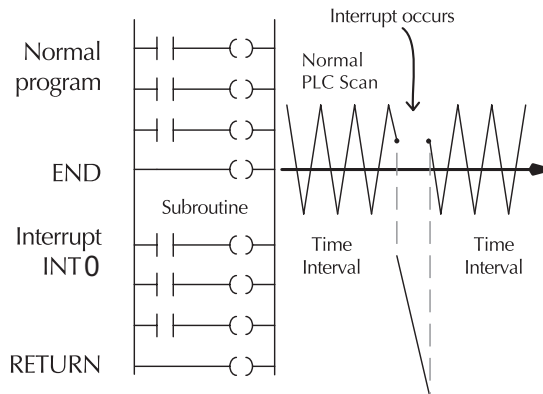

Instruction Set

Math Instructions (Accumulator)

- Add (ADD)**
Adds a BCD value in the lower 16 bits in the accumulator with a V memory location. The result resides in the accumulator.
- Add Double (ADDD)**
Adds a BCD value in the accumulator with two consecutive V memory locations or an 8-digit constant. The result resides in the accumulator.
- Add Real Number (ADDR)**
DL06 Only. Adds a real number in the accumulator with a real number constant or a real number contained in two consecutive V-memory locations. The result resides in the accumulator.
- Subtract (SUB)**
Subtract a BCD value, which is either a V memory location or a 4-digit constant from the lower 16 bits in the accumulator. The result resides in the accumulator.
- Subtract Double (SUBD)**
Subtracts a BCD value, which is either two consecutive V memory locations or an 8-bit constant, from a value in the accumulator. The result resides in the accumulator.
- Subtract Real Number (SUBR)**
DL06 Only. Subtracts a real number, which is either two consecutive V-memory locations or an 8-digit constant, from the real number in the accumulator. The result resides in the accumulator.
- Multiply (MUL)**
Multiplies a BCD value, which is either a V memory location or a 4-digit constant, by the value in the lower 16 bits in the accumulator. The result resides in the accumulator.
- Multiply Double (MULD)**
Multiplies a BCD value contained in two consecutive V memory locations by the value in the accumulator. The result resides in the accumulator.
- Multiply Real Number (MULR)**
DL06 Only. Multiplies a real number, which is either two consecutive V-memory locations or a real number constant, by the real number in the accumulator. The result resides in the accumulator.
- Divide (DIV)**
Divides a BCD value in the accumulator by a BCD value which is either a V memory location or a 4-digit constant. The result resides in the accumulator.
- Divide Double (DIVD)**
Divides a BCD value in the accumulator by a BCD value which is either two consecutive V memory locations or an 8-digit constant. The result resides in the accumulator.
- Divides Real Number (DIVR)**
DL06 Only. Divides a real number in the accumulator by a real number which is either two consecutive V-memory locations or a real number constant. The result resides in the accumulator.
- Increment (INC)**
Increments a BCD value in a specified V memory location by 1 each time the instruction is executed.
- Decrement (DEC)**
Decrements a BCD value in a specified V memory location by 1 each time the instruction is executed.
- Add Binary (ADDB)**
Adds the binary value in the lower 16 bits of the accumulator to a value which is either a V memory location or a 16-bit constant. The result resides in the accumulator.
- Add Binary Double (ADDDBD)**
DL06 Only. Adds the binary value in the accumulator to a value which is either two consecutive V-memory locations or a 32-bit constant. The result resides in the accumulator.
- Subtract Binary (SUBB)**
Subtract a 16-bit binary value, which is either a V memory location or a 16-bit constant, from the lower 16 bits in the accumulator. The result resides in the accumulator.
- Subtract Binary Double (SUBDBD)**
DL06 Only. Subtracts a 32-bit binary value, which is either two consecutive V-memory locations or a 32-bit constant, from the value in the accumulator. The result resides in the accumulator.
- Multiply Binary (MULB)**
Multiplies a 16-bit binary value, which is either a V memory location or a 16-bit constant, by the lower 16 bits in the accumulator. The result resides in the accumulator.
- Divide Binary (DIVB)**
Divides the binary value in the lower 16 bits in the accumulator by a value which is either a V memory location or a 16-bit constant. The result resides in the accumulator.
- Increment Binary (INCB)**
Increments a binary value in a specified V memory location by 1 each time the instruction is executed.
- Decrement Binary (DECB)**
Decrements a binary value in a specified V memory location by 1 each time the instruction is executed.
- Add Formatted (ADDF)**
DL06 Only. Adds the BCD value in the accumulator to a value which is a range of discrete bits (1-32). The result resides in the accumulator.
- Subtract Formatted (SUBF)**
DL06 Only. Subtracts a BCD value which is a range of discrete bits (1-32) from the BCD value in the accumulator. The result resides in the accumulator.
- Multiply Formatted (MULF)**
DL06 Only. Multiplies a BCD value in the lower 16-bits in the accumulator by a BCD value which is a range of discrete bits (1-16). The result resides in the accumulator.
- Divide Formatted (DIVF)**
DL06 Only. Divides the BCD value in the lower 16-bits in the accumulator by the BCD value which is a range of discrete bits (1-16). The result resides in the accumulator.
- Add Top of Stack (ADDS)**
DL06 Only. Adds the BCD value in the accumulator with the BCD value in the first level of the accumulator stack. The result resides in the accumulator.
- Subtract Top of Stack (SUBS)**
DL06 Only. Subtracts the BCD value in the first level of the accumulator stack from the BCD value in the accumulator. The result resides in the accumulator.

- Multiply Top of Stack (MULS)**
DL06 Only. Multiplies a 4-digit BCD value in the first level of the accumulator stack by a 4-digit BCD value in the accumulator. The result resides in the accumulator.
- Divide by Top of Stack (DIVS)**
DL06 Only. Divides the 8-digit BCD value in the accumulator by the 4-digit BCD value in the first level of the accumulator stack. The result resides in the accumulator.
- Add Binary Top of Stack (ADDBS)**
DL06 Only. Adds the binary value in the accumulator with the binary value in the first accumulator stack location. The result resides in the accumulator.
- Subtract Binary Top of Stack (SUBBS)**
DL06 Only. Subtracts the binary value in the first level of the accumulator stack from the binary value in the accumulator. The result resides in the accumulator.
- Multiply Binary Top of Stack (MULBS)**
DL06 Only. Multiplies the 16-bit binary value in the first level of the accumulator stack by the 16-bit binary value in the accumulator. The result resides in the accumulator.
- Divide Binary Top of Stack (DIVBS)**
DL06 Only. Divides a value in the accumulator by the binary value in the top location of the stack. The accumulator contains the result

Transcendental Instructions (DL06 only)

- Square Root Real (SQRTR)**
Takes the square root of the real number stored in the accumulator. The result resides in the accumulator.
- Sine Real (SINR)**
Takes the sine of the real number stored in the accumulator. The result resides in the accumulator.
- Cosine Real (COSR)**
Takes the cosine of the real number stored in the accumulator. The result resides in the accumulator.
- Tangent Real (TANR)**
Takes the tangent of the real number stored in the accumulator. The result resides in the accumulator.
- ARC Sine Real (ASINR)**
Takes the inverse sine of the real number stored in the accumulator. The result resides in the accumulator.
- ARC Cosine Real (ACOSR)**
Takes the inverse cosine of the real number stored in the accumulator. The result resides in the accumulator.
- ARC Tangent Real (ATANR)**
Takes the inverse tangent of the real number stored in the accumulator. The result resides in the accumulator.

Bit Instructions (Accumulator)

- Sum (SUM)**
Counts the number of bits set to "1" in the accumulator. The HEX result resides in the accumulator.
- Shift Left (SHFL)**
Shifts the bits in the accumulator a specified number of places to the left.
- Shift Right (SHFR)**
Shifts the bits in the accumulator a specified number of places to the right.
- Rotate Left (ROTL)**
Rotates the bits in the accumulator a specified number of places to the left.
- Rotate Right (ROTR)**
Rotates the bits in the accumulator a specified number of places to the right.
- Encode (ENCO)**
Encodes the bit position set to 1 in the accumulator, and returns the appropriate binary representation in the accumulator.
- Decodes (DECO)**
Decodes a 5 bit binary value (0-31) in the accumulator by setting the appropriate bit position to a 1.

Number Conversion Instructions (Accumulator)

- Binary (BIN)**
Converts the BCD value in the accumulator to the equivalent binary value. The result resides in the accumulator.
- Binary Coded Decimal (BCD)**
Converts the binary value in the accumulator to the equivalent BCD value. The result resides in the accumulator.
- Invert (INV)**
Takes the one's complement of the 32-bit value in the accumulator. The result resides in the accumulator.
- Ten's Complement (BCDCPL)**
DL06 Only. Takes the 10's complement (BCD) of the 8-digit accumulator.
- ASCII to HEX (ATH)**
Converts a table of ASCII values to a table of hexadecimal values.
- HEX to ASCII (HTA)**
Converts a table of hexadecimal values to a table of ASCII values.
- Segment (SEG)**
DL06 Only. Converts four digit HEX value in accumulator to seven segment display format.
- Gray Code to BCD (GRAY)**
Converts a 16-bit GRAY code value in the accumulator to a corresponding BCD value. The result resides in the accumulator.
- Shuffle Digits (SFLDGT)**
Shuffles a maximum of 8 digits, rearranging them in a specified order. The result resides in the accumulator.
- Radian Real Conversion (RADR)**
DL06 Only. Converts the real degree value in the accumulator to the equivalent real number in radians. The result resides in the accumulator.
- Degree Real Conversion (DEGR)**
DL06 Only. Converts the real radian value in the accumulator to the equivalent real member of degrees. The result resides in the accumulator.

- Binary to Real Number (BTOR)**
DL06 Only. Converts the binary value in the accumulator into a real number. The result resides in the accumulator.
- Real to Binary (RTOB)**
DL06 Only. Converts the real number in the accumulator into a binary value. The result resides in the accumulator.

Table Instructions

- Move (MOV)**
Moves the values from one V memory table to another V memory table.
- Move Memory Cartridge/Load Label (MOVMC/LDLBL)**
DL05 Only. Copies data between V memory and program ladder memory.
- Set Bit (SETBIT)**
DL06 Only. Sets a single bit (to a 0) in a V-memory location.
- Reset Bit (RSTBIT)**
DL06 Only. Resets a single bit (to a 0) in a V-memory location.

Extended Table Instructions (DL06 only)

- Fill (FILL)**
Fills a table of specified V-memory locations with a value which is either a V-memory location or a 4-digit constant.
- Find (FIND)**
Finds a value in a V-memory table and returns the table position containing the value to the accumulator.
- Find Greater Than (FDGT)**
Finds a value in a V-memory table which is greater than the specified search value. The table position containing the value is returned to the accumulator.
- Find Block (FINDB)**
Finds a block of data values in a V-memory table and returns the starting address of the table containing the values to the accumulator.
- Table to Destination (TTD)**
Moves the value from the top of a V-memory table to a specified V-memory location. The table pointer increments each scan.
- Remove from Bottom (RFB)**
Moves the value from the bottom of a v-memory table to a specified V-memory location. The table pointer increments each scan.
- Source To Table (STT)**
Moves a value from a specified V-memory location to a V-memory table. The table pointer increments each scan.
- Remove from Top (RFT)**
Pops a value from the top of a V-memory table and stores it in a specified V-memory location. All other values in the V-memory table are shifted up each time a value is popped from the table.
- Add To Top of Table (ATT)**
Pushes a value from a specified V-memory location onto the top of a V-memory table. All other values in the V-memory table are shifted down each time a value is pushed onto the table.
- Table Shift Left (TSHFL)**
Shifts a specified number of bits to the left in a V-memory table.
- Table Shift Right (TSHFR)**
Shifts a specified number of bits to the right in a V-memory table.
- And Move (ANDMOV)**
Copies data from a table to the specified location, ANDing each word with the accumulator data as it is written.
- Or Move (ORMOV)**
Copies data from a table to the specified memory location, ORing each word with the accumulator data as it is written.
- Exclusive Or Move (XORMOV)**
Copies data from a table to the specified memory location, XORing each word with the accumulator data as it is written.
- Swap (SWAP)**
Exchanges the data in two tables of equal length.

Clock / Calendar Instructions

- Date (DATE)**
Use to set the date in the CPU.
- Time (TIME)**
Use to set the time in the CPU.

CPU Control Instructions

- No Operation (NOP)**
Inserts a no operation coil at specified program address.
- End (END)**
Marks the termination point for the normal program scan. An End instruction is required at the end of the main program body.
- Stop (STOP)**
Changes the operational mode of the CPU from Run to Program (Stop).
- Reset Watchdog Timer (RSTWT)**
Resets the CPU watchdog timer.

Program Control Instructions

- Goto Label (GOTO) (LBL)**
Skips all instructions between the Goto and corresponding LBL instructions. **DL06 units only.** Not available in DL05.
- For/Next (FOR/NEXT)**
Executes the logic between the FOR and NEXT instructions a specified number of times.
- Goto Subroutine (GTS/SBR/RT/RTC)**
When a GTS instruction is executed the program jumps to the SBR (Subroutine). The subroutine is terminated with a RT instruction (unconditional return). When a return is executed, the program continues from the instruction after the calling GTS instruction. The RTC (Subroutine return conditional) instruction is used with an input contact to implement a conditional return from the subroutine.
- Master Line Set/Master Line Reset (MLS/MLR)**
Allows the program to control sections of ladder logic by forming a new power rail. The MLS marks the beginning of a power rail and the MLR marks the end of the power rail control.

Instruction Set

Interrupt Instructions

Interrupt Routine/Interrupt Return/Interrupt Return Conditional (INT/IRT/IRTC)

When a hardware or software interrupt occurs, the interrupt routine will be executed. The INT instruction is the beginning of the interrupt routine. The interrupt routine is terminated with an IRT of the interrupt routine. The interrupt routine is terminated with an IRT instruction (unconditional interrupt return). When an interrupt return is reached the execution of the program continues from the instruction where the program execution was prior to the interrupt.

Enable Interrupt (ENI)

Enables hardware and software interrupts to be acknowledged.

Disable Interrupt (DISI)

Disables hardware and software interrupts from being acknowledged.

Intelligent I/O Instructions

Read from Intelligent Module (RD)

Reads a block of data from an intelligent I/O module into CPU's V memory.

Write to Intelligent Module (WT)

Writes a block of data to an intelligent I/O module from a block of CPU's V memory.

Message Instructions

Fault/Data Label (FAULT/DLBL)

Displays a V memory value or a data label constant to the handheld programmer or personal computer using DirectSOFT.

Numerical Constant/ASCII constant (NCON/ACON)

Stores constants in numerical or ASCII form for use with other instructions.

Print Message (PRINT)

Prints the embedded text or text/data variable message to the specified communications port. Maximum message length is 255 words. appropriate bit position to 1 in the accumulator.

Network Instructions

Read from network (RX)

Reads a block of data from another CPU on the network.

Write to network (WX)

Writes a block of data from the master device to a slave device on the network.

Drum Instructions

Tuned Drum with Discrete Outputs (DRUM)

Time driven drum with up to 16 steps and 16 discrete output points. Output status is written to the appropriate output during each step. Specify a time base per count (in milliseconds). Each step can have a different number of counts to trigger the transition to the next step. Also define preset step as destination when reset occurs.

Time & Event Drum with Discrete Outputs (EDRUM)

Time and/or event driven drum with up to 16 steps and 16 discrete output points. Output status is written to the appropriate output during each step. Specify a time base per count (in milliseconds). Each step can have a different number of counts and an event to trigger the counting. Once the time has expired, a transition to the next step occurs. Also define preset step as destination when reset occurs.

Time and Event Drum with Discrete Outputs and Output Mask (MDRMD)

DL06 Only. Time and/or event driven drum with up to 16 steps and 16 discrete output points. Actual output status is the result of a bit-by-bit AND between the output mask and bit mask in the step. Specify a time base per count (in milliseconds). Each step can have a different number of counts and an event to trigger the counting. Once the time has expired, a transition to the next step occurs. Also define present step as destination when reset occurs.

Time and Event Drum with Word Output and Output Mask (MDRMW)

DL06 Only. Time and/or event driven drum with up to 16 steps and a single V-memory output location. Actual output word is the result of a bit-by-bit AND between the word mask and the bit mask in the step. Specify a time base per count (in milliseconds). Each step can have a different number of counts and an event to trigger the counting. Once the time has expired, a transition to the next step occurs. Also define preset step as destination when reset occurs.

RLL^{PLUS} Programming Instructions

Initial stage (ISG)

The initial stage instruction is used for a starting point for user application program. The ISG instruction will be active on power up and PROGRAM to RUN transitions.

Stage (SG)

Stage instructions are used to create structured programs. They are program segments which can be activated or deactivated with control logic.

Jump (JMP)

Normally open coil that deactivates the active stage and activates a specified stage when there is power flow to the coil.

Not Jump (NJMP)

Normally closed coil that deactivates the active stage and activates a specified stage when there is power flow to the coil.

Converge Stages (CV)

Converge stages are a group of stages that when all stages are active the associated converge jump(s). (CVJMP) will activate another stage(s). One scan after the CVJMP is executed, the converge stages will be deactivated.

Converge Jump (CVJMP)

Normally open coil that deactivates the active CV stages and activates a specified stage when there is power flow to the coil.

Block Call/Block/Block End (BCALL w/BLK and BEND)

DL06 Only BCALL is a normally open coil that activates a block of stages when there is power flow to the coil. BLK is the label which marks the beginning of a block of stages. Bend is a label used to mark the end of a block of stages

LCD Display Instructions (DL06 only)

LCD

Configures LCD display.

MODBUS Instructions (DL06 only)

MODBUS Read (MRX)

Used CPU port 2 to read a block of data from MODBUS RTU devices on the network.

MODBUS Write (MWX)

Writes a block of data from CPU port 2 to MODBUS RTU devices on the network.

ASCII Instructions (DL06 only)

ASCII IN (AIN)

Configures port 2 to read raw ASCII input strings.

ASCII Find (AFIND)

Searches ASCII strings in V-memory to find a specific portion of the string.

ASCII IN (AEX)

Extracts a specific portion from an ASCII string.

Compare V-memory (CMPV)

Compares two blocks of V-memory.

Swap Bytes (SWAPB)

Swaps V-memory bytes.

Print to V-memory (VPRINT)

Used to send pre-coded ASCII strings to a pre-defined V-memory address when enabled.

Print from V-memory (PRINTV)

Used to write raw ASCII string out of port 2 when enabled.

Company
InformationControl Systems
Overview

CLICK PLC

Do-More
PLCs OverviewDo-More H2
PLCDo-More T1H
PLCDirectLOGIC
PLCs OverviewDirectLOGIC
DL05/06DirectLOGIC
DL105DirectLOGIC
DL205DirectLOGIC
DL305DirectLOGIC
DL405Productivity
Controller
OverviewProductivity
3000Universal
Field I/O

Software

C-More
HMIC-More Micro
HMIViewMarq
Industrial
Marquees

Other HMI

Communications

Appendix
Book 1Terms and
Conditions

