

Fuji Odyssey Series 3N Contactors



Description

- 180 - 361A rating (AC3)
- Provides higher current and horsepower capabilities than SC-E series. Designed for reliable use in applications requiring constant switching, reduced coil energy-consumption, and increased horsepower capabilities.
- Available in 154 mm and 169 mm frame widths
- SUPERMAGNET™ for high operating reliability.
- Use with Odyssey 3N series overload relays.

Features

- Equipped with 2 N.O. and 2 N.C. auxiliary contacts
- Chatter-free operation eliminates contact welding and coil burning
- SUPERMAGNET™ coil operates on either AC or DC voltage
- Wire Terminal Connection Type: Crimp ring Terminal (See page 17-55 for specs)



3NC4H0122

Agency approvals

- UL listed file E42419, Standard UL508
- cUL listed file E42419, Standard CSA C22.2 No. 14
- CE: Meets LVD EN60947-4-1
- SEMI F47-0200

Optional accessories

- Replacement coils
- Terminal covers

Ecology

- Low power consumption
- Recycled thermoplastic resin used for plastic parts.
- The names of materials are indicated on all major parts to facilitate recycling.

Please note: \$US prices shown
For current \$AUD visit www.directautomation.com.au

Odyssey 3N Series Contactors 180–361 Amps															
Part Number	Fuji Type	Price	Coil Voltage	Rated Motor Capacity (HP)						Rated AC-3 Current (A) [note 1]	Rated AC-1 Thermal Current (A) [note 2]	Quantity of Auxiliary Contacts		SCCR Ratings (KA)	Frame Width (mm)
				3-Phase				1-Phase				NO	NC		
				200–208V	220–240V	440–480V	550–600V	100–120V	220–240V						
3NC4Q0E22	SC-N8	<--->	24–25VAC / 24VDC	60	60	150	150	180	260	10	138				
3NC4Q0122		<--->	100–127VAC / 100–120VDC												
3NC4Q0222		<--->	200–250VAC / 200–240VDC												
3NC4Q0Q22		<--->	380–450VAC												
3NC4Q0422		<--->	460–575VAC												
3NC4H0E22	SC-N10	<--->	24–25VAC / 24VDC	75	75	150	200	221	260	2	2				
3NC4H0122		<--->	100–127VAC / 100–120VDC												
3NC4H0222		<--->	200–250VAC / 200–240VDC												
3NC4H0Q22		<--->	380–450VAC												
3NC4H0422		<--->	460–575VAC												
3NC5F0E22	SC-N11	<--->	24–25VAC / 24VDC	100	100	200	250	285	350	18	148				
3NC5F0122		<--->	100–127VAC / 100–120VDC												
3NC5F0222		<--->	200–250VAC / 200–240VDC												
3NC5F0Q22		<--->	380–450VAC												
3NC5F0422		<--->	460–575VAC												
3NC5H0E22	SC-N12	<--->	24–25VAC / 24VDC	125	150	300	350	361	450						
3NC5H0122		<--->	100–127VAC / 100–120VDC												
3NC5H0222		<--->	200–250VAC / 200–240VDC												
3NC5H0Q22		<--->	380–450VAC												
3NC5H0422		<--->	460–575VAC												

Notes: 1. AC3 type loads consist of squirrel cage three-phase motors; occasional, limited jogging duty.
 2. AC1 non-inductive or slightly inductive loads. Typically resistive loads (i.e. furnaces, ovens, etc.)

Contactor Coil Characteristics - AC Input						
Part Number	Power Consumption (VA)		Pick-up Voltage (V)	Drop-out Voltage (V)	Operating Time (ms)	
	Inrush	Sealed			Coil ON to Contact ON	Coil OFF to Contact OFF
3NC4Qxxxx, 3NC4Hxxxx	277	5.4	70-80	35-50	35-41	37-45
3NC5Fxxxx, 3NC5Hxxxx	265	5.9	70-80	35-50	40-47	36-43

NOTE: This data is based on 100-120V SUPERMAGNET™ coil, tested at 120VAC, 60Hz.

Fuji Odyssey Series 3N Contactors

Contactor Coil Characteristics - DC Input - 110VDC

Part Number	Power Consumption (watts)		Pick-up Voltage (V)	Drop-out Voltage (V)	Operating Time (ms)	
	Inrush	Sealed			Coil ON to Contact ON	Coil OFF to Contact OFF
3NC4Qxxxx, 3NC4Hxxxx	324	4.1	77-88	28-44	35-41	37-45
3NC5Fxxxx, 3NC5Hxxxx	340	4.5	77-88	28-44	40-47	36-43

NOTE: This data is based on 100-120V SUPERMAGNET™ coil, tested at 110VDC.

Contactor Coil Characteristics - DC Input - 24VDC

Part Number	Power Consumption (watts)		Pick-up Voltage (V)	Drop-out Voltage (V)	Operating Time (ms)	
	Inrush	Sealed			Coil ON to Contact ON	Coil OFF to Contact OFF
3NC4Qxxxx, 3NC4Hxxxx	250	5.9	17-19.2	6-12	35-41	37-45

NOTE: This data is based on 100-120V SUPERMAGNET™ coil, tested at 110VDC.

Contactor Auxiliary Contact Ratings

NEMA ICS 5-2000 Ratings (note 1)

AC Ratings			DC Ratings	
Designation	Making VA	Breaking VA	Designation	Making/Breaking VA
A600	7200	720	Q300	69

Note 1: NEMA ICS 5-2000. For more information, refer to Control Circuit Contact Electrical Ratings, page 16-75.

Contactor Terminal Tightening Torque Chart

Part Number	Terminal Size	Cable Size Maximum	Applicable Max. Width for Ring Terminal	Tightening Torque
3NC4Q0XXX	M10	300MCM (152mm ²)	36.5mm	133-177 in.lbs. 15-20 Nm
3NC4H0XXX	M10	300MCM (152mm ²)	36.5mm	133-177 in.lbs. 15-20 Nm
3NC5F0XXX 3NC5H0XXX	M12	400MCM (203mm ²)	44.5mm	310-399 in.lbs. 35-45 Nm

Contactor Life Expectancy Performance Data

Model	Current Capacity Make/Break	Operating Cycles per Hour	Life Expectancy (million operations)	
			Electrical	Mechanical
3NC4Qxxxx through 3NC5Fxxxx	12xle/10xle	1200	1	5
3NC5Hxxxx	12xle/10xle	1200	0.5	5

Note: Rated operational current. Electrical life test: Conforming to IEC947-4-1, AC3. The endurance test complies with the requirements of international standard IEC, JIS and JEM.

Note: Super Magnet Coils on 3NC4 and 3NC5 series contactors have internal surge suppression. See diagram below.

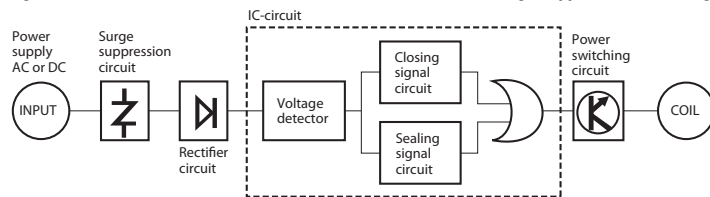

Optional accessories

Terminal covers

Prevent contact with electrified terminals.



SZ-N8T



SZ-N11T

Replacement contactor coils



SZ-GSN11-100

Odyssey Series Contactor Terminal Covers

Part Number	Price	Description	Applicable Contactors
SZ-N8T	<--->	Terminal cover for line or load side. Prevents contact with electrified contactor terminals.	3NC4Qxxxx, 3NC4Hxxxx contactors
SZ-N11T	<--->		3NC5Fxxxx, 3NC5Hxxxx contactors

Odyssey Series Replacement Contactor Coils

Part Number	Price	Applicable Contactors	Coil Voltage
SZ-GSN8-100	<--->	3NC4Q0122, 3NC4H0122	100-127VAC/100-120VDC
SZ-GSN11-100	<--->	3NC5F0122, 3NC5H0122	100-127VAC/100-120VDC
SZ-GSN8-200		3NC4Q0222, 3NC4H0222	200-250VAC/200-240VDC
SZ-GSN11-200		3NC5F0222, 3NC5H0222	200-250VAC/200-240VDC
SZ-GSN8-24	<--->	3NC4Q0E22, 3NC4H0E22	24-25VAC/24VDC
SZ-GSN11-24	<--->	3NC5F0E22, 3NC5H0E22	24-25VAC/24VDC

Replacement coils are not available for coil codes Q and 4 (380-450VAC and 460-575VAC).

Fuji Odyssey Series 3N Contactors

Dimensions (mm)

3NC4Q0#22
3NC4H0#22

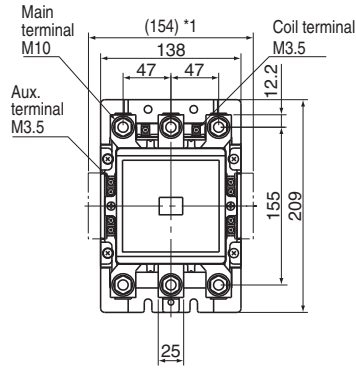
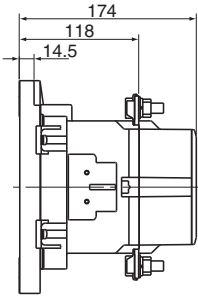

* 1 Aux. contact block (Side mounted)

Weight: 4.9kg

3NC5F0#22
3NC5H0#22

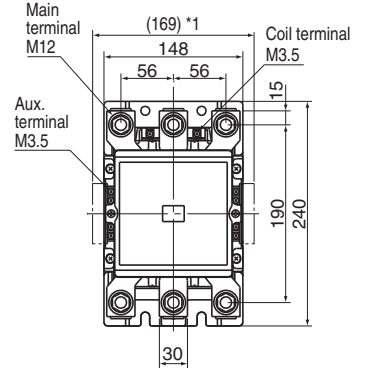
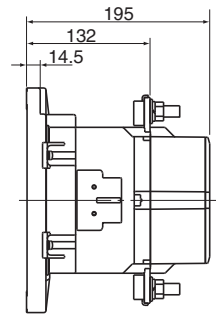

* 1 Aux. contact block (Side mounted)

Weight: 7.8kg

Mounting dimensions

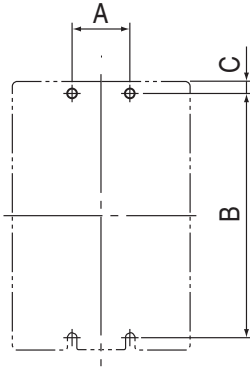

Frame Size	A	B	C	Screw Size
3NC4Qxxxx	45	190	9.5	4-M6
3NC4Hxxxx	45	190	9.5	4-M6
3NC5Fxxxx	60	220	10	4-M8
3NC5Hxxxx	60	220	10	4-M8



Wiring diagrams

Non-reversing Contactors

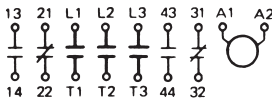

Fuji Odyssey Series 3N Overload Relays

General information

- Use with Odyssey 3N series contactors.
- Protects motor windings from burning due to overloads, locked rotor currents, or open phases.

Agency approvals:

- UL listed file E42419, Standard UL 508
- cUL listed file E42419, Standard CSA C22.2 No. 14
- CE: LVD EN60947-4-1



3NK4QK



3NK4HN



3NK5HQ

Odyssey Series Overload Relays

Part Number	Fuji Type	Price	Adjustable Current Range (A)	Frame Width	Compatible Contactor
3NK4QK	TK-N8	<--->	65 - 95	119mm	3NC4Qxxxx
3NK4QL	TK-N8	<--->	85 - 125		
3NK4QN	TK-N8	<--->	110 - 160		
3NK4QP	TK-N8	<--->	125 - 185		
3NK4HL	TK-N10	<--->	85 - 125	138mm	3NC4Hxxxx
3NK4HN	TK-N10	<--->	110 - 160		
3NK4HP	TK-N10	<--->	125 - 185		
3NK4HQ	TK-N10	<--->	160 - 240		
3NK5HN	TK-N12	<--->	110 - 160	142mm	3NC5Fxxxx 3NC5Hxxxx
3NK5HP	TK-N12	<--->	125 - 185		
3NK5HQ	TK-N12	<--->	160 - 240		
3NK5HR	TK-N12	<--->	200 - 300		
3NK5HS	TK-N12	<--->	240 - 360		
3NK5HT	TK-N12	<--->	300 - 450		3NC5Hxxxx

Specifications

Overload Relay Alarm Contact Ratings

AC Ratings <small>(note 1)</small>			DC Ratings <small>(note 1)</small>	
Designation	Making VA	Breaking VA	Designation	Making/Breaking VA
C600	1800	180	---	---

Notes:
1. NEMA ICS 5-2000. For more information, refer to Control Circuit Contact Electrical Ratings, page 16-75.

Wire Terminal Tightening Torque Chart

Part Number	Contactor or Starter	Terminal Size	Cable Size Maximum	Applicable Max. Width for Ring Terminal	Tightening Torque
3NK4Qx	3NC4Q0	M10	300MCM (152mm ²)	36.5mm	133-177 in.lbs., 15-20 Nm
3NK4Hx	3NC4H0	M10	300MCM (152mm ²)	36.5mm	133-177 in.lbs., 15-20 Nm
3NK5Hx	3NC5F0	M12	400MCM (203mm ²)	44.5mm	310-399 in.lbs., 35-45 Nm
	3NC5H0				

Fuji Odyssey Series 3N Overload Relays Selection Tables

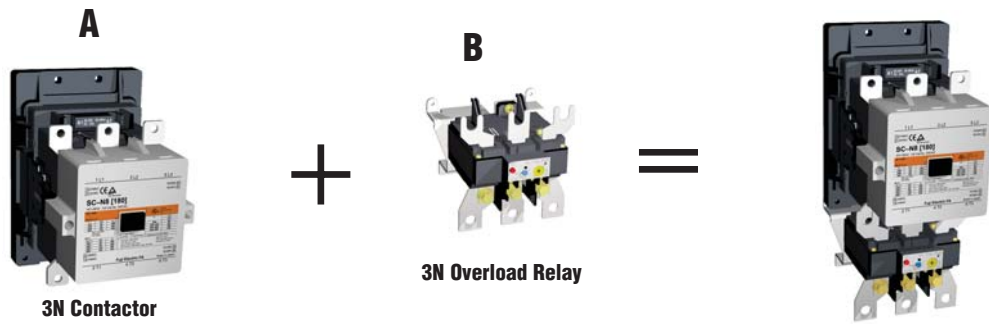

- Step 1. Select an Odyssey 3N contactor from Column A based on motor voltage and horsepower.
- Step 2. Select an Odyssey 3N overload relay from Column B to work with the contactor selected in Step 1. The motor full load current (FLA) should be within the adjustable current range of the overload relay.

220-240V 3-Phase Motor (60 to 150 hp)

Motor Rating		A	B	
HP	Motor Full Load Amperage (FLA) (See Note 1)	Contactor	Overload Relay	
			Part Number	Adjustable Current Range
60	154	3NC4Q0x22	3NK4QN	110 to 160 Amps
75	192	3NC4H0x22	3NK4HQ	160 to 240 Amps
100	248	3NC5F0x22	3NK5HR	200 to 300 Amps
125	312	3NC5H0x22	3NK5HS	240 to 360 Amps
150	360	3NC5H0x22	3NK5HT	300 to 450 Amps

Note 1: Per NEC 2005 Table 430.250

440-480V 3-Phase Motor (125 to 300 hp)

Motor Rating		A	B	
HP	Motor Full Load Amperage (FLA) (See Note 1)	Contactor	Overload Relay	
			Part Number	Adjustable Current Range
125	156	3NC4Q0x22	3NK4QP	125 to 185 Amps
150	180	3NC4H0x22	3NK4HQ	160 to 240 Amps
200	240	3NC5F0x22	3NK5HR	200 to 300 Amps
250	302	3NC5H0x22	3NK5HS	240 to 360 Amps
300	361	3NC5H0x22	3NK5HT	300 to 450 Amps

Note 1: Per NEC 2005 Table 430.250

Fuji Odyssey Series 3N Overload Relays

Specifications

Ambient temperature compensator

Overload relays are provided with an ambient temperature compensator. Their characteristics limit current value changes to approximately 10% as the ambient temperature changes between -5°C and 40°C .

Compensation characteristics (Average value)

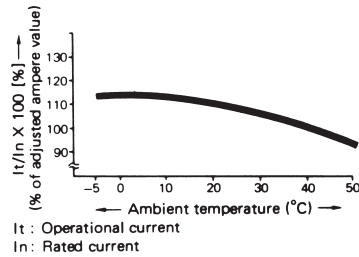

Open-phase protection

3NK4Qx

Cold start

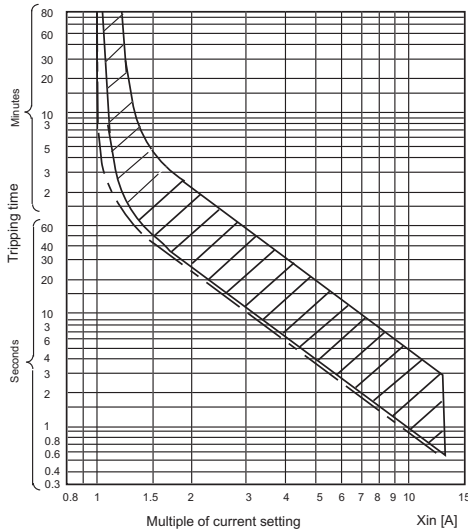

Hot start

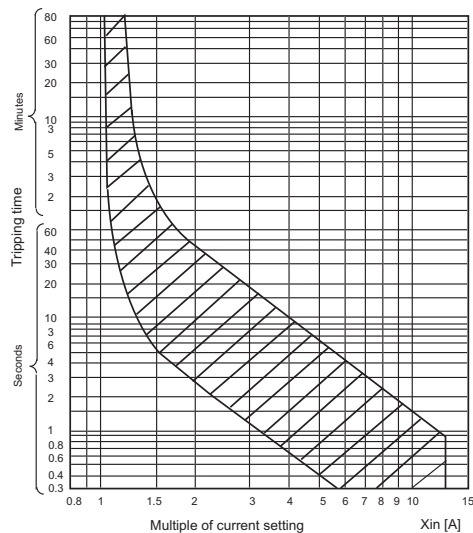

3NK4Hx, 3NK5Hx

Cold start

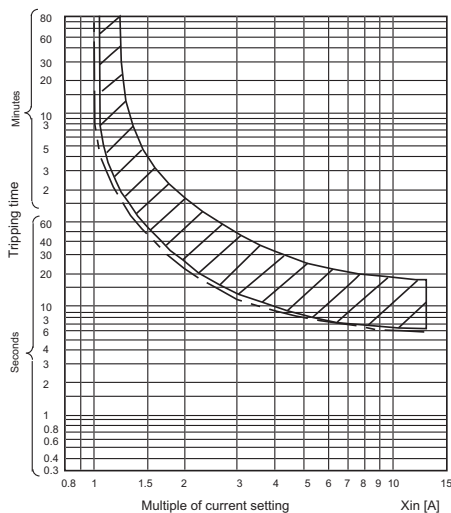

Hot start

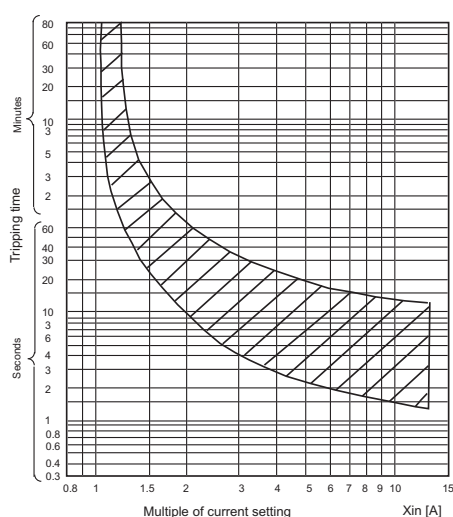

Fuji Odyssey Series 3N Overload Relays

Optional accessories

Terminal covers

NOTE: Larger terminal covers may require some adjustment for proper fit.



SZ-WN8T



SZ-WN10T



SZ-WN11T



Odyssey Series Overload Relay Terminal Covers			
Part number	Price	Description	Applicable Contactors, Overload Relays
SZ-WN8T	<--->		3NK4Qx overload relays
SZ-WN10T	<--->	Terminal cover for load side. Prevents contact with electrified contactor terminals.	3NK4Hx overload relays
SZ-WN11T	<--->		3NK5Hx overload relays

Dimensions (mm)

3NK4Qx

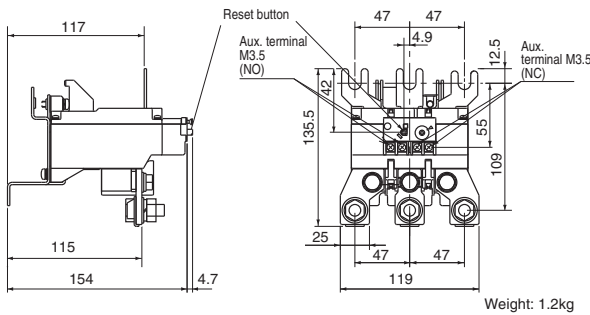

3NK4Hx

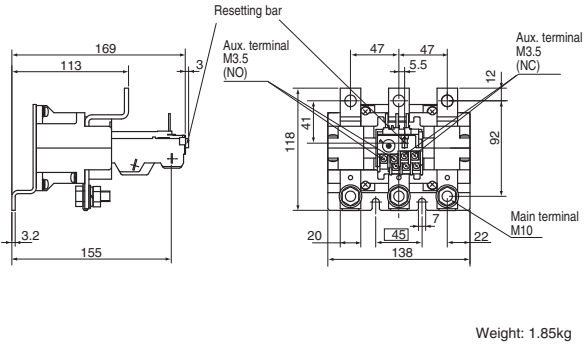

3NK5Hx

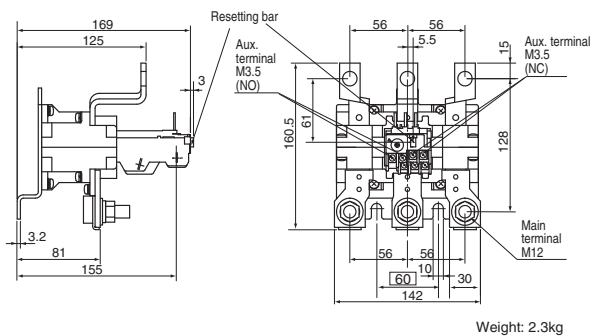

Wiring diagrams

3NK4Qx

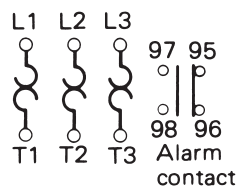

3NK4Hx, 3NK5Hx

